

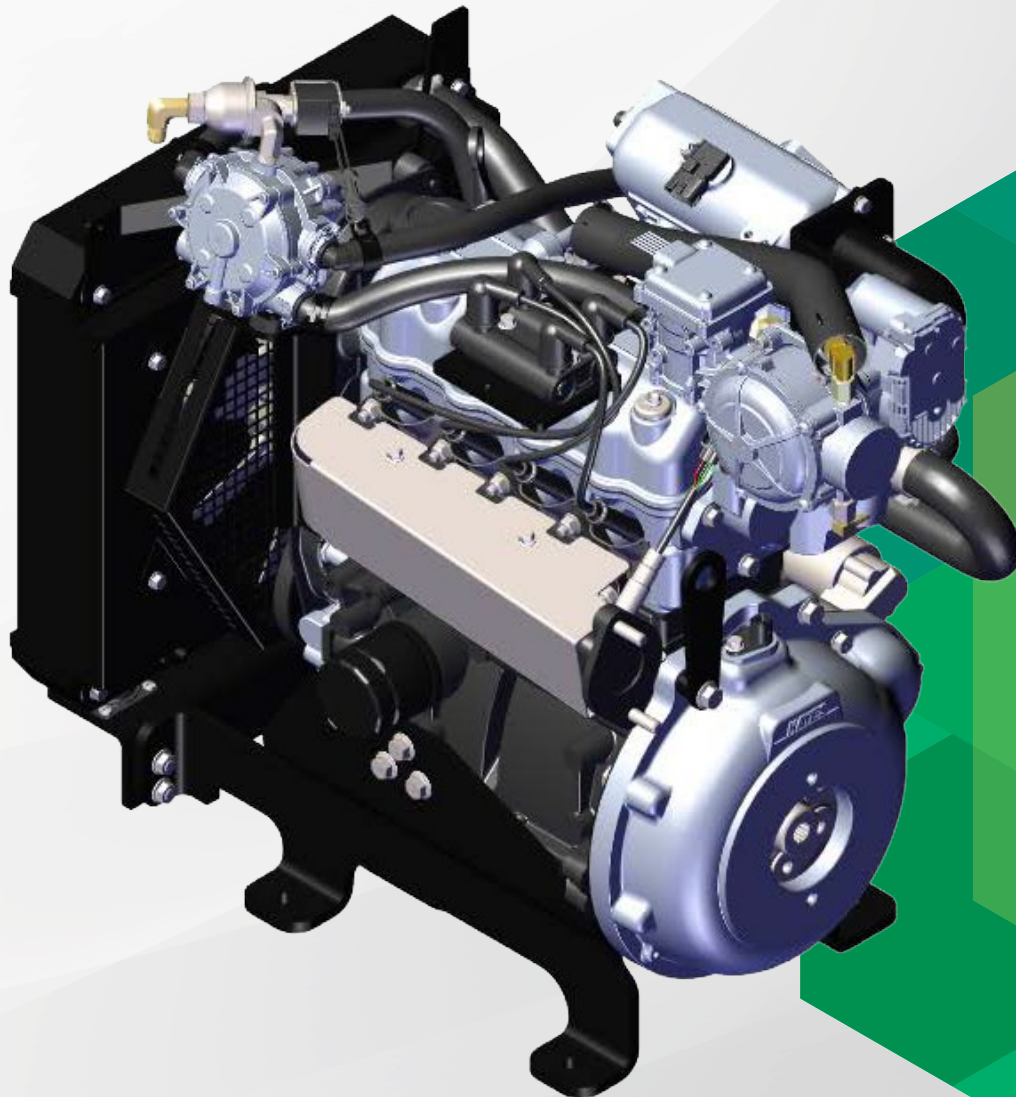

**POWER SOLUTIONS
INTERNATIONAL**

0.998L



Service Manual

Table of Contents

General Information	3
<i>An overview of this Service Manual</i>	
Maintenance	6
<i>General maintenance and maintenance interval information</i>	
Base Engine Repair	13
<i>Torque Specifications, Timing Belt, and Valve Lash Procedure</i>	
LPG Fuel System	35
<i>An overview of the fuel system and its components</i>	
GASOLINE Fuel System	43
<i>An overview of the fuel system and its components</i>	
Fuel System Diagnosis	48
<i>How to identify a general problem</i>	
Electrical Section	64
Diagnostic Scan Tool	66
<i>Using the DST for testing and trouble shooting</i>	
Engine Wire Harness Repair	88
<i>Repairing a wire harness on the vehicle</i>	
Diagnostic Trouble Codes (DTCs)	92
<i>Application, schematic and DTC specific code information</i>	
Definitions	267
<i>Definitions of phrases and acronyms used throughout this Service Manual</i>	

General Information

INTRODUCTION

This service manual has been developed to provide the service technician with the basic understanding of the PSI certified fuel and emission systems for their SSI engine line.

SERVICING YOUR EMISSIONS CERTIFIED ENGINE

Any maintenance and repair should be performed by trained and experienced service technicians. Proper tools and equipment should be used to prevent injury to the servicing technician and damage to the vehicle or components. Service repairs should always be performed in a safe environment and the technician should always wear protective clothing to prevent injury.

FUEL QUALITY

PSI LPG engines and fuel systems are designed to operate on HD-5 or HD-10 specification LPG fuel. Fuel other than HD-5 or HD-10 may cause harm to the engine's emission control system and a warranty claim may be denied on this basis if operators can readily find the proper fuel. Gasoline engines should use 87 octane or higher. E85 fuel is not permitted for use in the gasoline engine. Use of any other fuel may result in your engine no longer operating in compliance with CARB or EPA emissions requirements.

FUEL SYSTEM CAUTIONS

	CAUTION
Do not smoke, carry lighted tobacco or use a lighted flame of any type when working on or near any fuel related component. Highly flammable air-fuel mixtures may be present and can be ignited causing personal injury	

	CAUTION
Do not allow LPG to contact the skin. LPG is stored in the fuel tank as a liquid. When LPG contacts the atmosphere, it immediately expands into a gas, resulting in a refrigeration effect that can cause severe burns to the skin.	

	CAUTION
Do not allow LPG to accumulate in areas below ground level such as in a service pit or underground ventilation systems. LPG is heavier than air and can displace oxygen, creating a dangerous condition	

	CAUTION
Do not make repairs to the LPG fuel system if you are not familiar with or trained to service LPG fuel system. Contact the dealer who sold you the vehicle to locate a repair facility with trained technicians to repair your fuel system	

WARNINGS, CAUTIONS AND NOTES

This manual contains several different Warnings, Cautions, and Notes that must be observed to prevent personal injury and or damage to the vehicle, the fuel system or personal property.

A **“WARNING”** is an advisement that by performing a process or procedure listed in this manual improperly may result in serious bodily injury, death and/or serious damage to the vehicle or property.

PROPER USE OF THIS SERVICE MANUAL, TOOLS AND EQUIPMENT

To reduce the potential for injury to the technician or others and to reduce damage to the equipment during service repairs the technician should observe the following steps:

- The service procedures defined in this manual, when followed, have been found to be a safe and efficient process to repair the fuel system. In some cases, special tools may be required to perform the necessary procedures to safely remove and replace a failed component.
- The fuel system has been certified with the Environmental Protection Agency (EPA) and complies with the regulation in effect at the time of certification. When servicing the fuel and emission control system you should follow all the recommended service and repair procedures to insure the fuel and emissions system is operating as designed and certified. Purposely or knowingly defeating or disabling any part of the fuel and emission system may be in violation of the anti-tampering provision of the EPA's Clean Air Act.
- Special tools identified in this manual can be acquired through the equipment OEM or PSI.

IMPORTANT

It is important to remember that there may be a combination of Metric and Imperial fasteners used in the installation of the PSI fuel system. Check to insure proper fit when using a socket or wrench on any fastener to prevent damage to the component being removed or injury from "slipping off" the fastener.



WARNING

Always leak check any fuel system connection after servicing! Use an electronic leak detector and/or a liquid leak detection solution. Failure to leak check could result in serious bodily injury, death, or serious property damage.

Maintenance

MAINTENANCE

The maintenance of an engine and related components are critical to its operating performance and lifespan. Industrial engines operate in environments that often include hot and cold temperatures and extreme dust. The recommended maintenance schedule is listed in this section, however, environmental operating conditions and additional installed equipment may require more frequent inspection and servicing.

The owner and/or service agent should review the operating conditions of the equipment to determine the inspection and maintenance intervals.



WARNING

When performing maintenance on the engine, turn the ignition OFF and disconnect the battery negative cable to avoid injury or damage to the engine.

The engine installed in this equipment uses a drive belt that drives the water pump, alternator and additional pumps or devices. It is important to note that the drive belt is an integral part of the cooling and charging system and should be inspected according to the maintenance schedule in this section. When inspecting the belts check for:

- Cracks
- Chunking of the belt
- Splits
- Material hanging loose from the belt
- Glazing, hardening

If any of these conditions exist, the belt should be replaced with the recommended OEM replacement belt.

SERPENTINE BELT SYSTEM

Serpentine belts utilize a spring-loaded tensioner to keep the belt properly adjusted. Serpentine belts should be checked according to the maintenance schedule in this section.

IMPORTANT:

The use of “belt dressing” or “anti-slipping agents” on belts is not recommended.

COOLING SYSTEM

It is important that the cooling system of the engine be maintained properly to ensure proper performance and longevity.



WARNING

Do not remove the cooling system pressure cap (radiator cap) when the engine is hot. Allow the engine to cool and then remove the cap slowly to allow pressure to vent. Hot coolant under pressure may discharge violently.

Note that there may be an LPG vaporizer \ connected to the cooling system and the fuel system may be adversely affected by low coolant levels and restricted or plugged radiator cores. Therefore, the cooling system must be maintained according to the recommended maintenance schedule in this section and also include:

- The regular removal of dust, dirt and debris from the radiator core and fan shroud.
- Inspection of coolant hoses and components for leaks, especially at the radiator hose connections. Tighten hose clamps if necessary.
- Check radiator hoses for swelling, separation, hardening, cracks or any type of deterioration. If any of these conditions exist, the hose should be replaced with a recommended OEM replacement part.
- Inspect the radiator cap to ensure proper sealing.

COOLANT

The engine manufacturer recommends the cooling system be filled with a 50/50 mixture of antifreeze and water. The use of DexCool “Long Life” type coolant is required. This antifreeze is typically a bright orange in color and should meet the requirements issued by PSI. Coolant should have a minimum boiling point of 300F (149c) and a freezing point no higher than -34F (-37c). Do not add plain water. Replace coolant per the recommended schedule.

IMPORTANT:

The manufacturers of the engine and fuel system do not recommend the use of “stop leak” additives to repair leaks in the cooling system. If leaks are present, the radiator should be removed and repaired or replaced.

ENGINE ELECTRICAL SYSTEM MAINTNANCE

The engine’s electrical system incorporates an electronic control module (ECM) to control various related components. The electrical system connections and ground circuits require good connections. Follow the recommended maintenance schedule in this section to maintain optimum performance. When inspecting the electrical system check the following:

- Check Positive and Negative cables for corrosion, rubbing, chafing, burning and to ensure tight connections at both ends.
- Check battery for cracks or damage to the case and replace if necessary.
- Inspect engine wire harness for rubbing, chafing, pinching, burning, and cracks or breaks in the wiring.
- Verify that engine harness connectors are correctly locked in by pushing in and then pulling the connector halves outward.
- Inspect ignition coil wire for hardening, cracking, arcing, chafing, burning, separation, split boot covers.
- Check spark plug wires for hardening, cracking, chafing, arcing or burning, separation, and split boot covers.
- Replace spark plugs at the required intervals per the recommended maintenance schedule.
- Verify that all electrical components are securely mounted to the engine or chassis.
- Verify that any additional electrical services

installed by the owner are properly installed in the system.

- Verify that the MIL, charging, and oil pressure lights illuminate momentarily during engine start.

ENGINE CRANKCASE OIL

OIL RECOMMENDATION

To achieve proper engine performance and durability, it is important that you only use engine lubricating oils displaying the American Petroleum Institute (API) “Starburst” Certification Mark ‘FOR GASOLINE ENGINES’ on the container or oils that meet the GB oil standards referenced below.



Gasoline engines that are converted to run on LPG or NG fuels must use oils labeled for gasoline engines. Oils specifically formulated for Heavy Duty or Natural Gas Engines are not acceptable

The recommended oil grades are as follows:

- SF 15W/40 GB 11121-1995 engine oil (or API SG SAE15W40 engine oil) is used above an ambient temperature -20°C (-4°F).
- SF 5W/30 GB 11121-1995 petrol engine oil (or API SG SAE5W30 engine oil) is used below an ambient temperature -20°C (-4°F).

IMPORTANT:

Oils recommended by the engine manufacturer already contain a balanced additive treatment. Oils containing “solid” additives, non-detergent oils, or low quality oils are not recommended by the engine manufacturer. Supplemental additives added to the engine oil are not necessary and may be harmful. The engine and fuel system supplier do not review, approve or recommend such products.

SYNTHETIC OILS

Synthetic oils have been available for use in industrial engines for a relatively long period of time and may offer advantages in cold and hot temperatures. However, it is not known if synthetic oils provide operational or economic benefits over conventional petroleum-based oils in industrial engines. Use of synthetic oils does not permit the extension of oil change intervals.

CHECKING/FILLING ENGINE OIL LEVEL

IMPORTANT:

Care must be taken when checking engine oil level. Oil level must be maintained between the "ADD" mark and the "FULL" mark on the dipstick. To ensure that you are not getting a false reading, make sure the following steps are taken before checking the oil level.

1. Stop engine.
2. Allow approximately several minutes for the oil to drain back into the oil pan.
3. Remove the dipstick. Wipe with a clean cloth or paper towel and reinstall. Push the dipstick all the way into the dipstick tube.
4. Remove the dipstick and note the amount of oil on the dipstick. The oil level must be between the "FULL" and "ADD" marks.

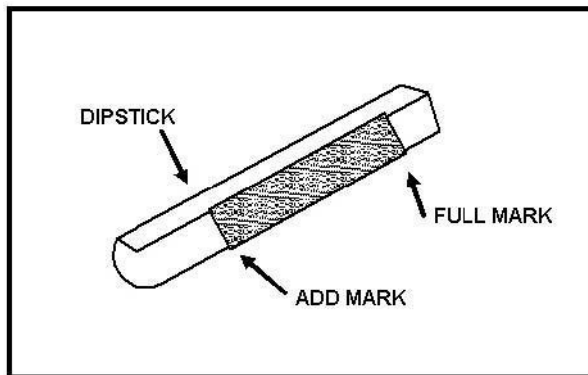

Figure 2 Engine Oil Dip tick (Typical)

5. If the oil level is below the "ADD" mark reinstall the dipstick into the dipstick tube and proceed to Step 6.
6. Remove the oil filler cap from the valve cover.
7. Add the required amount of oil to bring the level up to, but not over, the "FULL" mark on the dipstick. Reinstall the oil filler cap to the

valve rocker arm cover and wipe any excess oil clean.

CHANGING THE ENGINE OIL

IMPORTANT:

When changing the oil, always change the oil filter.

1. Start the engine and run until it reaches normal operating temperature.



CAUTION

An overfilled crankcase (oil level being too high) can cause an oil leak, a fluctuation or drop in oil pressure. When overfilled, the engine crankshafts splash and agitate the oil, causing it to aerate or foam.

IMPORTANT:

Change oil when engine is warm and the old oil flows more freely.

2. Stop engine

IMPORTANT:

Engine oil will be hot. Use protective gloves to prevent burns. Engine oil contains chemicals which may be harmful to your health. Avoid skin contact.

3. Remove drain plug and allow the oil to drain.
4. Remove and discard oil filter and its sealing ring.
5. Coat sealing ring on the new filter with clean engine oil, wipe the sealing surface on the filter mounting surface to remove any dust, dirt or debris. Tighten filter securely (follow filter manufacturers instructions). Do not over-tighten.
6. Check sealing ring on drain plug for any damage, replace if necessary, wipe plug with clean rag, wipe pan sealing surface with clean rag

and re-install plug into the pan. Tighten to specification.

7. Fill crankcase with oil.
8. Start engine and check for oil leaks.
9. Dispose of oil and filter in a safe manner.

OIL PAN REMOVAL

1. Drain oil pan by removing the oil drain plug. Ensure to drain into a suitable container.
2. Remove the 3 bolts from the crank end cover, then remove the 18 bolts from under the oil pan. Removing the engine mounts from the sides of the oil pan will make for an easy removal process.
3. Remove the oil pan and gasket.

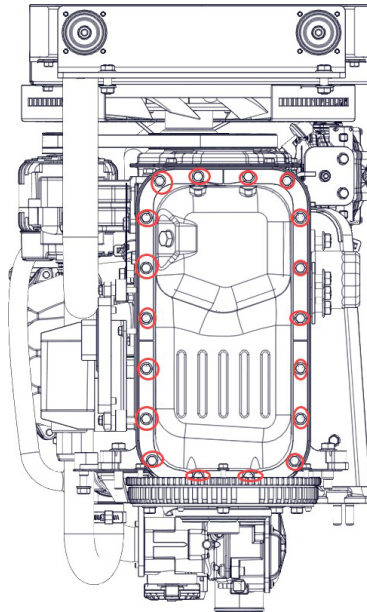

Figure 1 Engine Oil Pan

OIL PAN INSTALLATION

1. Remove any and all debris from below the engine block.
2. Apply HZ-1213 silicone sealant to the oil pan gasket and crank end cover.
3. Install the oil pan and insert and torque the bolts to 7-9 Nm in the below sequence (1-18).
4. Torque the three crank end cover bolts to 7 Nm.
5. Any sealant extruding from the oil pan and crank end cover should be cut off.
6. Torque the oil drain plug to 4 Nm.

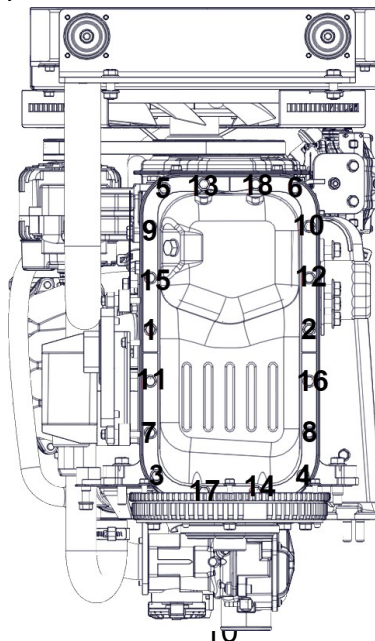

Figure 2 Oil Pan Bolt Torquing Sequence

FUEL SYSTEM INSPECTION AND MAINTENANCE

GASOLINE AND LPG FUEL SYSTEM

The fuel system installed on this industrial engine has been designed to meet the emissions standard applicable for the 2010 and later model years. To ensure compliance to these standards, follow the recommended maintenance schedule contained in this section.

INSPECTION AND MAINTENANCE OF THE FUEL STORAGE CYLINDER

The fuel storage cylinder should be inspected daily or at the beginning of each operational shift for any leaks, external damage, adequate fuel supply and to ensure the manual service valve is open. Fuel storage cylinders should always be securely mounted, inspect the securing straps or retaining devices for damage ensure that all locking devices are closed and locked. Check to ensure that the fuel storage cylinder is positioned with the locating pin in the tank collar on all horizontally mounted cylinders this will ensure the proper function of the cylinder relief valve.

When refueling or exchanging the fuel cylinder, check the quick fill valve for thread damage. Also verify O-ring is in place and inspect for cracks, chunking or separation. If damage to the o-ring is found, replace prior to filling. Check the service line quick coupler for any thread damage.

IMPORTANT:

When refueling the fuel cylinder, wipe both the female and male connection with a clean rag prior to filling to prevent dust, dirt and debris from being introduced to the fuel cylinder.

INSPECTION AND REPLACEMENT OF THE FUEL FILTER

The fuel system on this emission certified engine may utilize an in-line replaceable fuel filter element. This element should be replaced, at the intervals specified in the recommended maintenance schedule. When inspecting the fuel filter check the following:

- Check for leaks at the inlet and outlet fittings, using a soapy solution or an electronic leak detector and repair if necessary.

- Check to make sure filter is securely mounted.
- Check filter housing for external damage or distortion. If damaged replace fuel filter.

REPLACING THE FUEL FILTER:

1. Move the equipment to a well ventilated area and verify that sparks, ignition and any heat sources are not present.
2. Start the engine.
3. If the engine operates on a positive pressure fuel system, run the engine with the fuel supply closed to remove fuel from the system.

IMPORTANT:

A small amount of fuel may still be present in the fuel line. Use gloves and proper eye protection to prevent burns. If liquid fuel continues to flow from the connections when removed, make sure the manual valve is fully closed.

4. Slowly loosen the inlet fitting and disconnect.
5. Slowly loosen the outlet fitting and disconnect.
6. Remove the filter housing from the equipment.
7. Check for contamination.
8. Tap the opening of the filter on a clean cloth.
9. Check for debris.
10. Check canister for proper mounting direction.
11. Reinstall the filter housing to the equipment.
12. Tighten the inlet and outlet fittings to specification.
13. Check for leaks at the inlet and outlet fittings, and the filter housing end connection using a soapy solution or an electronic leak detector, if leaks are detected make repairs

AIR FUEL MIXER/THROTTLE CONTROL DEVICE MAINTENANCE AND INSPECTION

IMPORTANT:

The Air Fuel Mixer components have been specifically designed and calibrated to meet the fuel system requirements of the emission certified engine. The mixer should not be disassembled or rebuilt. If the mixer fails to operate or develops a leak the mixer should be replaced with the OEM recommended replacement parts.

When inspecting the mixer check for the following items:

- Leaks at the inlet fitting.
- Fuel inlet hose for cracking, splitting or chaffing, replace if any of these condition exist.
- Ensure the mixer is securely mounted and is not leaking vacuum at the mounting gasket or surface.
- Inspect air inlet hose connection and clamp. Also inspect inlet hose for cracking, splitting or chafing. Replace if any of these conditions exist.
- Inspect Air cleaner element according to the Recommended Maintenance Schedule found in this section.
- Check Fuel lines for cracking, splitting or chafing. Replace if any of these conditions exist.
- Check for leaks at the throttle body and intake manifold.

EXHAUST SYSTEM AND CATALYTIC CONVERTER INSPECTION AND MAINTENANCE

IMPORTANT:

The exhaust system on this emission certified engine contains a Heated Exhaust Gas Oxygen Sensor (HEGO) which provides feed back to the ECM on the amount of oxygen present in the exhaust stream after combustion.

The oxygen in the exhaust stream is measured in voltage and sent to the ECM. The ECM then makes corrections to the fuel air ratio to ensure the proper fuel charge and optimum catalytic performance. Therefore, it is important that the exhaust connections remain secured and air tight.

IMPORTANT:

The HEGO sensor is sensitive to silicone based products. Do not use silicone sprays or hoses which are assembled using silicone lubricants. Silicone contamination can cause severe damage to the HEGO.

When inspecting the Exhaust system check the following:

- Exhaust manifold at the cylinder head for leaks and that all retaining bolts and shields (if used) are in place.
- Manifold to exhaust pipe fasteners to ensure they are tight and that there are no exhaust leaks repair if necessary.
- HEGO electrical connector to ensure connector is seated and locked, check wires to ensure there is no cracking, splits chafing or “burn through.” Repair if necessary.
- Exhaust pipe extension connector for leaks tighten if necessary
- If the engine is equipped with a catalytic converter inspect the converter to ensure it is securely mounted.
- Check for any leaks at the inlet and outlet of the converter.

Base Engine Repair

Torque Specifications for Base Engine

Name	Torque (N·m)
Cylinder head connecting bolt	55~68
Intake manifold bolt and nuts	17~21
Outlet manifold bolt nuts	18~23
Spark plug	20~28
Mounting bolt of camshaft timing sprocket	55~65
Adjusting nut of throttle valve	18~20
Crankshaft pulley mounting bolt (M12x1.25x28)	80~100
Connecting rod bearing cap nut	28~40
Crankshaft bearing cover bolt	43~55
Flywheel bolt	45~50
Oil discharge plug	30~35
Cylinder head cover bolt	6~8
Front and rear cover bolt	4~5
Oil pressure sensor	12~15
Oil filter pipe nipple	15~20
Fixed bolt of rear suspension bracket	18~23
Safety valve spring base of engine oil pump	15~20
Fixed bolt of the petrol engine suspension (left & right)	32~38
Tensioner mounting bolt	18~23

Serpentine Belt Removal

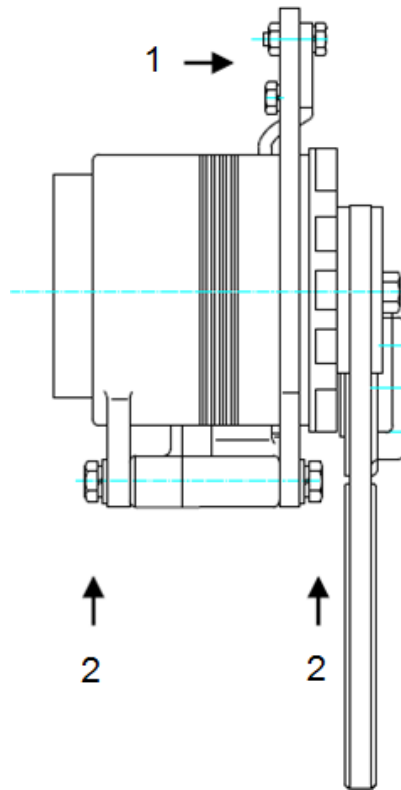

1. Loosen lower generator mounting bolts (2).
2. Loosen the upper generator adjusting bolt (1).
3. Move generator to release tension from serpentine belt.
4. Remove the serpentine belt from the pulleys.

Serpentine Belt Installation and Adjustment

1. Loosen two lower generator mounting bolts.
2. Loosen the upper generator adjusting bolt.
3. Adjust the generator until the generator belt meets its required tension.
4. Measure serpentine belt deflection by applying 98 Nm to the belt between the fan pulley and generator pulley.
5. Tighten the upper generator adjusting bolt.
6. Tighter two lower generator mounting bolts.

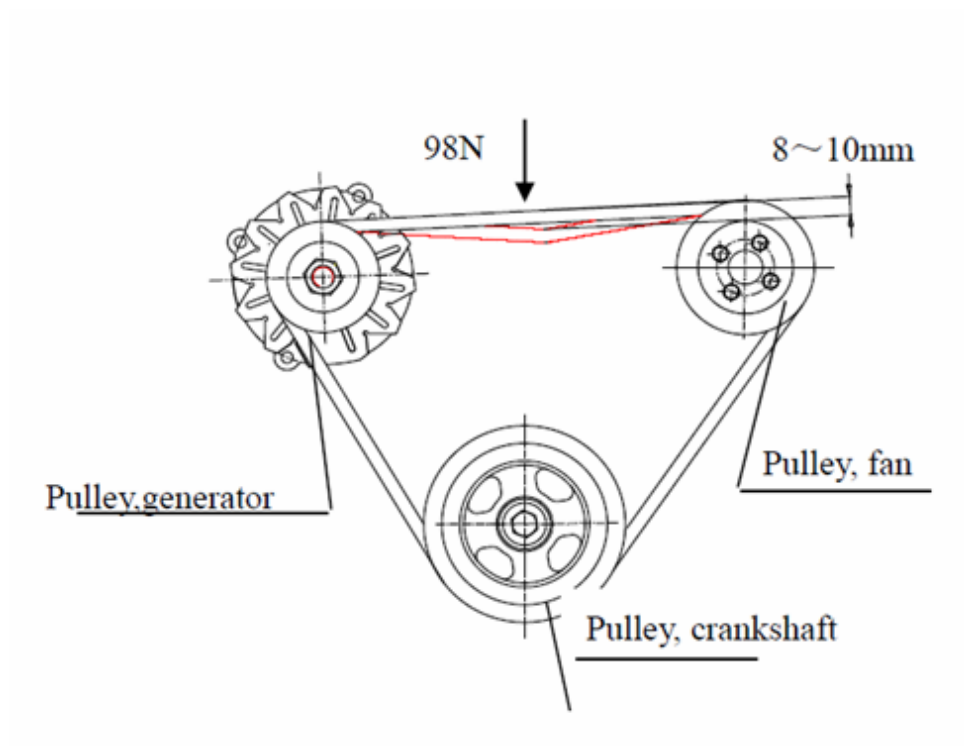

Engine Compression Test

Removal Procedure

1. With engine at operating temperature, detach spark plugs connectors and remove spark plugs from the engine
2. Detach wiring harness plug from ignition module
3. Open relay holder cover and pull the fuel pump relay out of the base.

Inspect

1. Install a compression gauge capable of measuring range up to 250 psi
2. Actuate starter for approx. 4 seconds with the throttle valve fully open, minimum engine speed should be 300 rpm.
3. Reinstall spark plugs, harness, and relay once compression test is completed

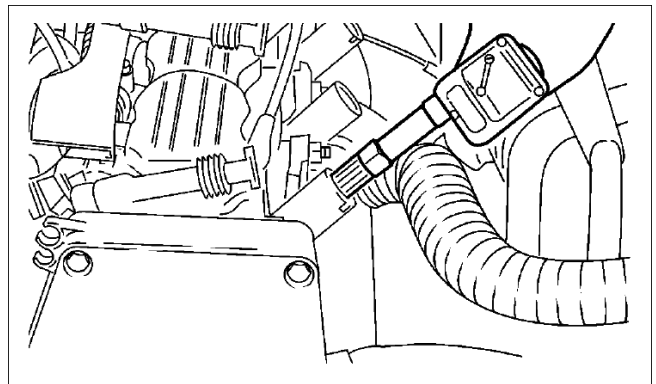

Compression pressure is normally at 194 psi (Min. 170 psi) at 300 rpm. Variation between cylinders should be no greater than 15 psi.

Valve Adjustment

Remove Valve cover and find camshaft timing belt per the following steps:

- 1) Loosen alternator bolts and remove fan belt.

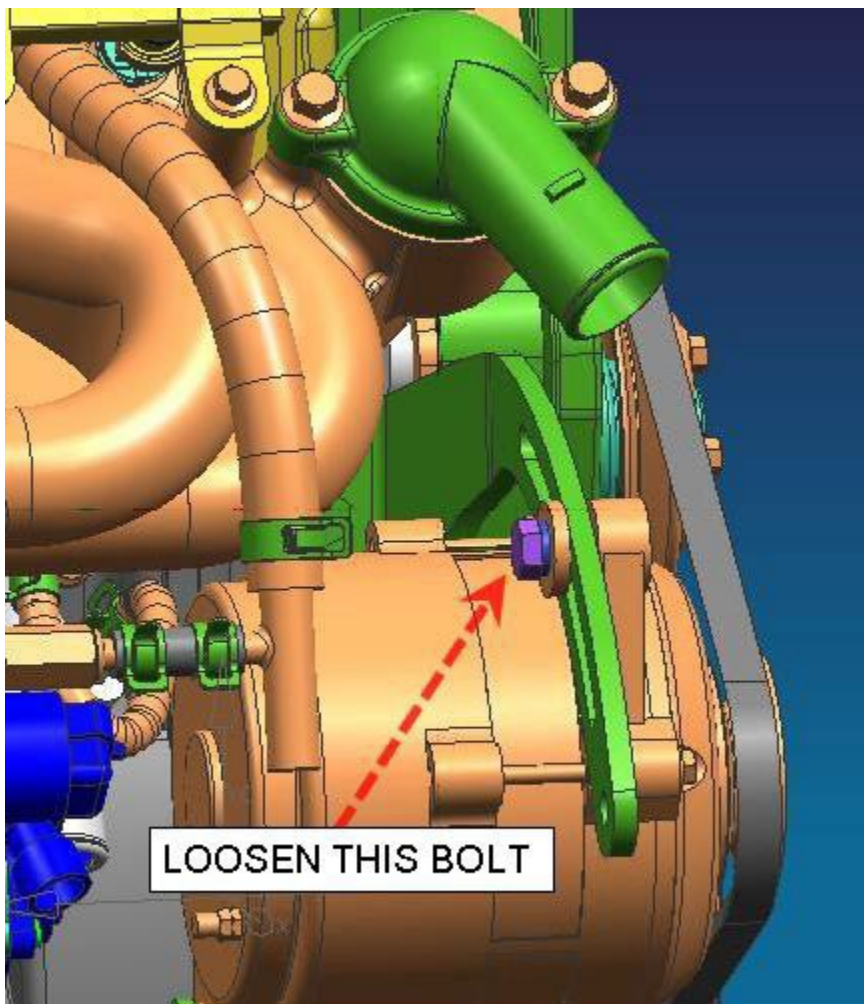

- 2) Remove bolts (4) from water pump pulley and remove water pump pulley

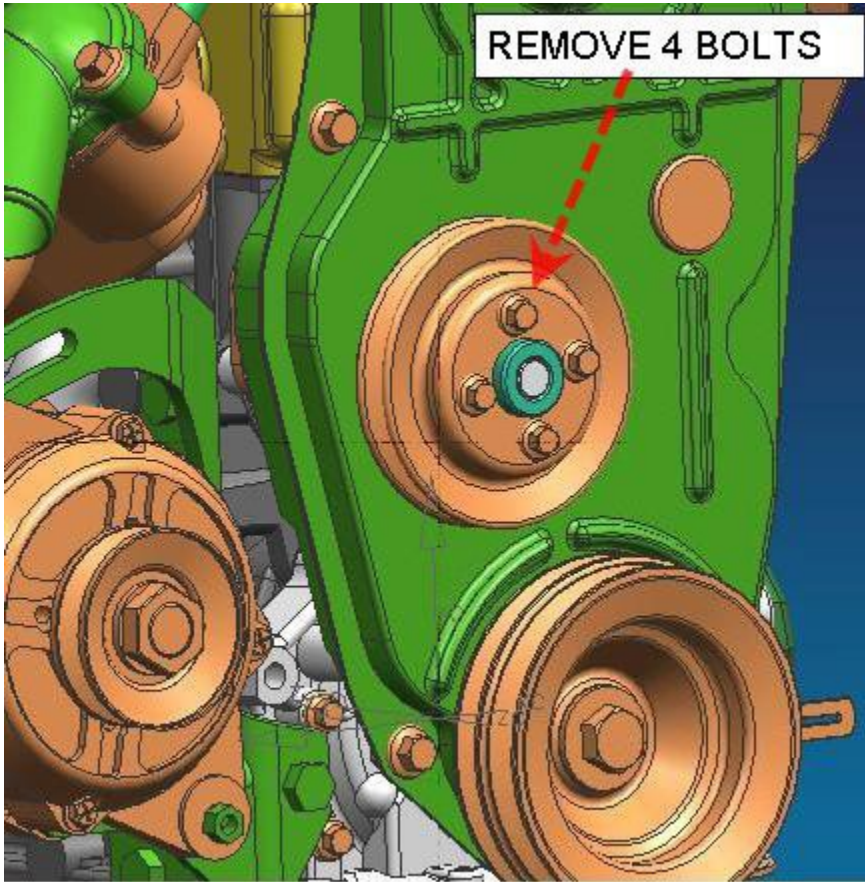

3) Remove driving pulley bolts and remove drive pulley

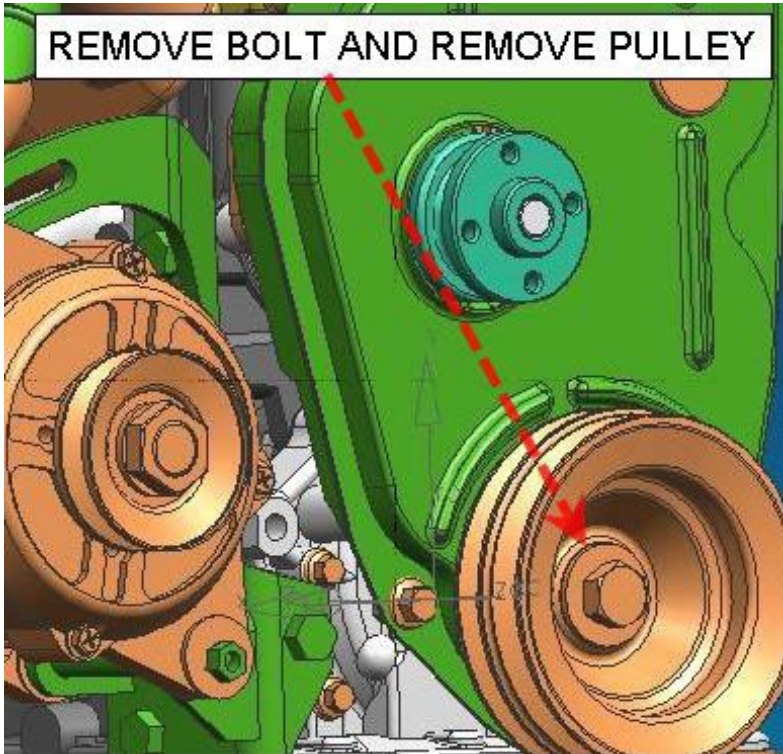

4) Remove six timing cover bolts and remove the timing cover

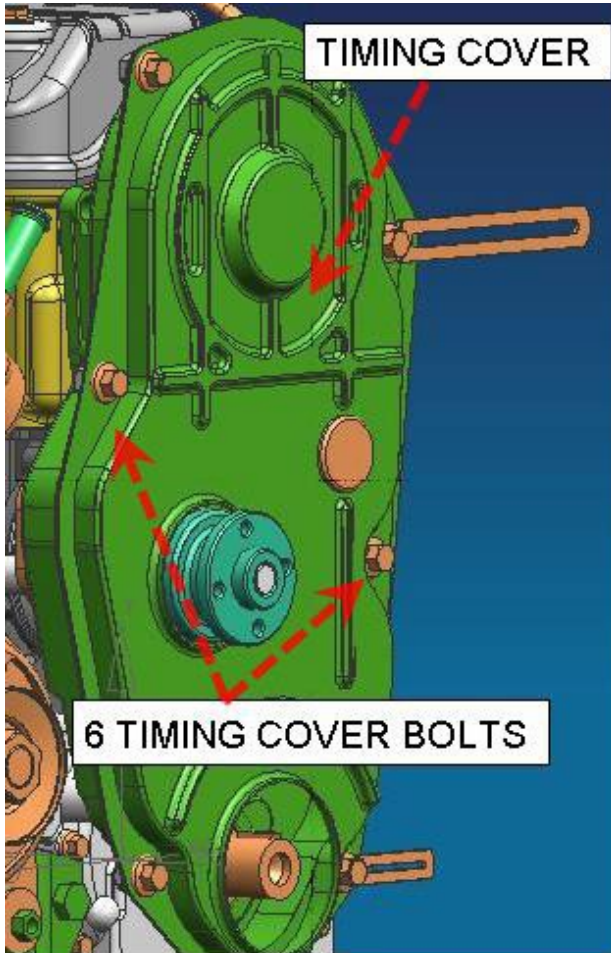

- 5) Turn the flywheel to align the • (dot) mark on the cam timing pulley with the ↑ (arrow) mark on the rear cover. Cylinder # 1 will be at TDC.
- 6) Adjust intake/exhaust valves on cylinder 1, intake valves on cylinder 2 and exhaust valve on cylinder 3.
- 7) Turn cam timing pulley to 180° (number 4 will be at TDC).
- 8) Adjust Intake/Exhaust valves on cylinder 4, exhaust valve on cylinder 2, and intake valve on cylinder 3.

Refer to the photo below.

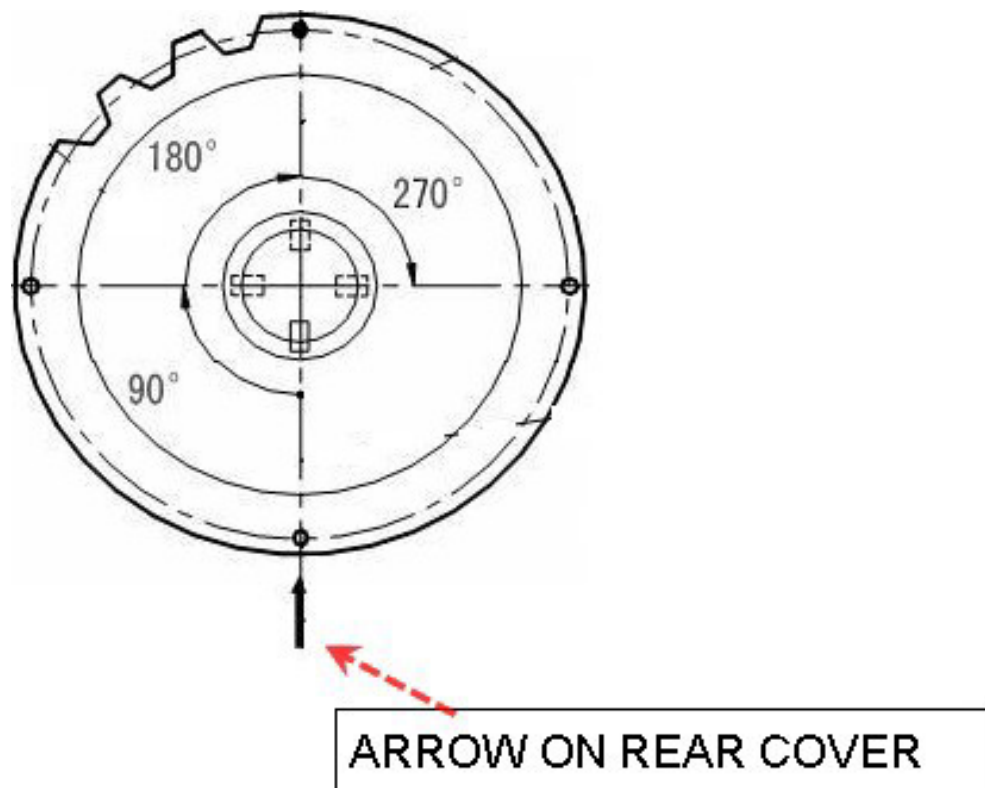

Valve Adjustment

Adjustment Range (mm):

Intake - 0.13-0.18 (Cold), 0.23-0.28 (Warm)

Exhaust - 0.13-0.18 (Cold), 0.23-0.28 (Warm)

The adjustment is done through an adjustment screw (1) and locking nut (2). When the rocker arm is at its highest position, use a thickness gauge to check the clearance between the bottom of the adjustment screw and the end of the valve stem. Then use the locking nut to lock the adjusting screw in place when the correct clearance is reached.

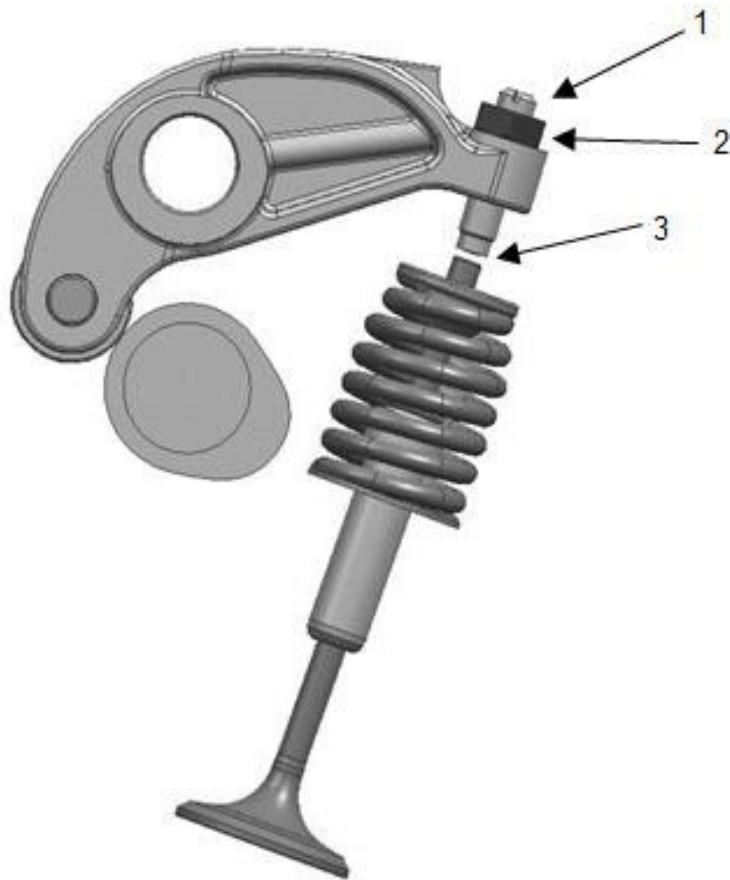

Figure 11 Valve Adjustment

Timing Check/Timing Belt Replacement

Remove the timing belt cover. Remove the #1-cylinder spark plug. Rotate the crankshaft clockwise, until the crankshaft vibration dampener keyway is at the 12 o'clock position and is pointing at the arrow molded into the rear of the timing cover. The keyway for the camshaft should be at the 6 o'clock position. This is TDC cylinder #1.

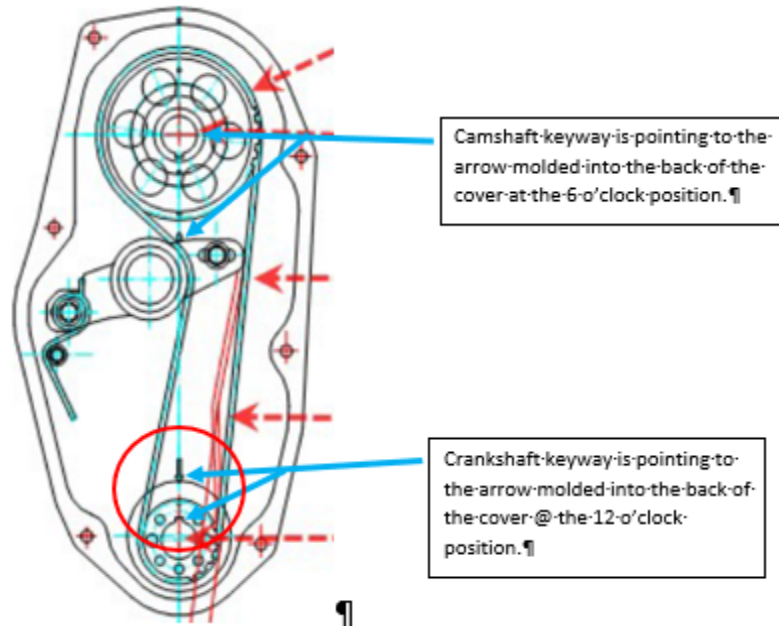

Figure 12 Timing Sprocket Adjustment

Timing Belt Removal:

Loosen the right-hand 12mm tensioner lock bolt (1-3 turns is sufficient), push tensioner assembly to the left to release timing belt tension (against spring pressure, then tighten the right-hand lock bolt to secure in the released position. Slide, with the help of a pick/awl, the timing belt forward off of the pulley/sprockets. Manipulate the timing belt off of the tensioner pulley, then the camshaft sprocket, then the crankshaft driving sprocket.

Installation of Timing Belt:

Note rotational direction marked on belt (CW as viewed from front of engine), route new belt starting on camshaft sprocket clockwise around and down to crankshaft sprocket while maintaining tension on belt. Once lock from cam-to-crank, of the belt teeth, slide left hand side of belt over tensioner pulley. Loosen tensioner RH lock bolt and apply tension to belt, tighten RH tensioner lock bolt to specification.

NOTE Rotate engine over CW 2 full rotations and ensure timing belt alignment marks line up correctly as stated at start of procedure.

Valve Lash Adjustment:

Once TDC cylinder 1 is set, with the rocker arm assemblies exposed, adjust both the intake & exhaust valves on cylinder 1, adjust the intake valve for cylinder 2, and exhaust valve on cylinder 3.

Rotate the cam gear 180 degrees by turning the crankshaft, this will set cylinder 4 at TDC. Now, adjust cylinder 4 intake & exhaust valves, adjust cylinder 2's exhaust valve, and cylinder 3's intake valve.

Valve lash settings:

Intake & Exhaust (Cold)-> 0.13-0.18

Intake & Exhaust (Warm)-> 0.23-0.28

1.

Check and Adjustment of Timing Sprocket

Open the sprocket chamber cover, check the mounting mark position of driving and driven sprockets is correct, if it's not correct or timing is not doubted correct, and perform inspection according to the following regulations:

Remove the spark plug, move the flywheel, observe the mark on the flywheel through the hole on the transmission, to ensure the key on the front end of the crankshaft align with the arrow inside the belt cover. Check the piston of the number one cylinder (near the radiator) at the up dead line of compression situation i.e. has gap at the intake, exhaust valve and adjust screw of the rocker arm. If it is not correct, turn the crankshaft 360° again, the mark on the driven synchronization gear (align with the key) will align with the arrow on the inner cover of the belt, if has different, adjust it, and check the tension of the belt according the requirement shown below.

Rotate the crankshaft 360° to ensure the number one cylinder at the top dead line at exhaust situation, the number four cylinder at top dead line at compression situation, one of the two marks on the synchronization belt must align with mark (Δ) on the belt cover

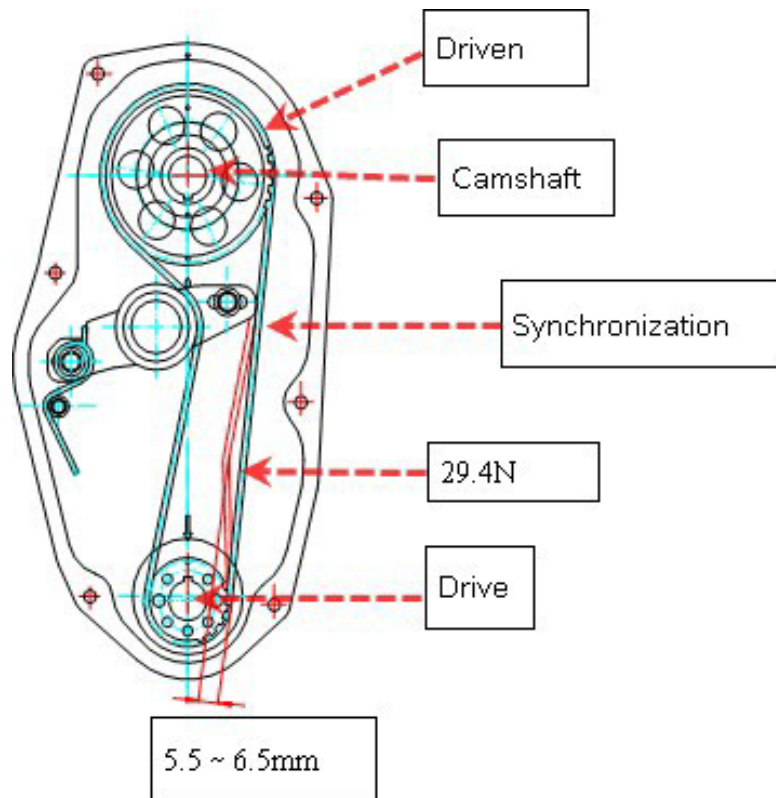

Starter Removal

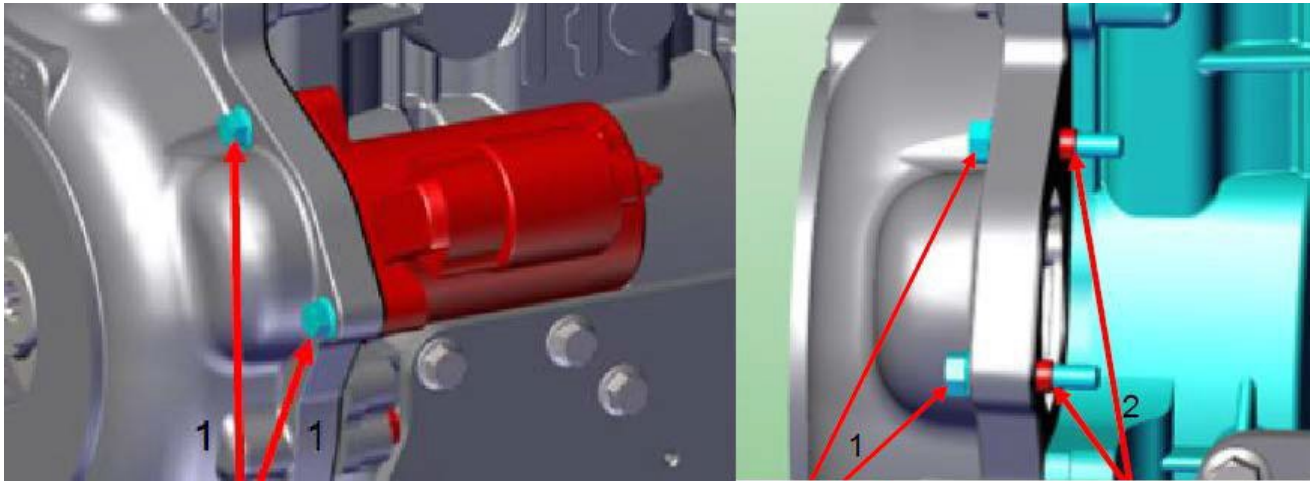

- 1) Remove starter mounting bolts (1) and dowels (2) from starter.
- 2) Remove the starter from flywheel housing.

Starter Installation

- 1) Install starter into flywheel using mounting bolts (1) and dowels (2).
- 2) Torque starter mounting bolts (1) to 23 ft/lbs.

Flywheel Housing and Backing Plate Removal

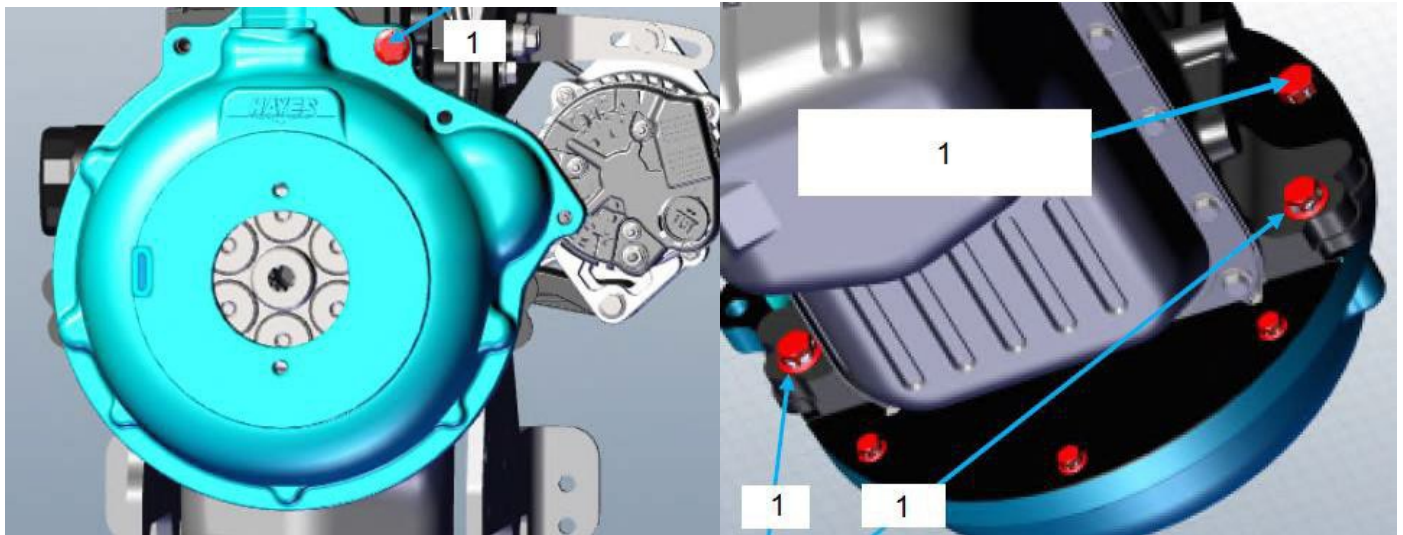

1) Remove flywheel housing mounting bolts (1) from the flywheel housing.

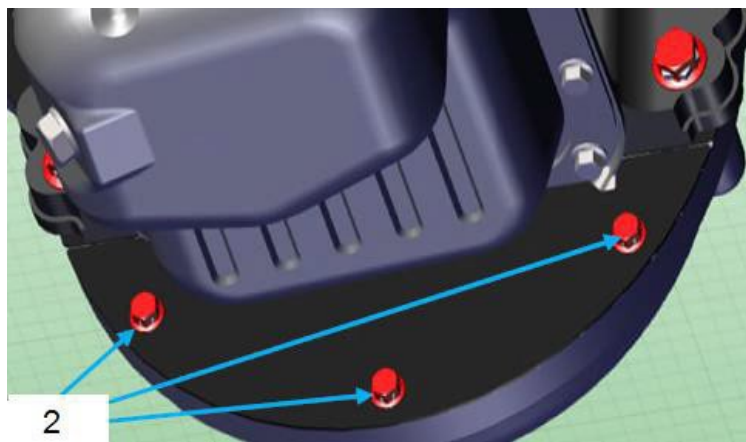

2) Remove flywheel housing backing plate bolts (2).

3) Remove the flywheel housing and backing plate from the engine.

Flywheel Housing and Backing Plate Installation

1) Install the backing plate on to the engine.

2) Install the flywheel housing using flywheel housing mounting bolts (1).

3) Torque flywheel housing mounting bolts (1) to 50 ft/lbs.

4) Install flywheel housing backing plate using backing plate mounting bolts (2).

Flex Plate Removal

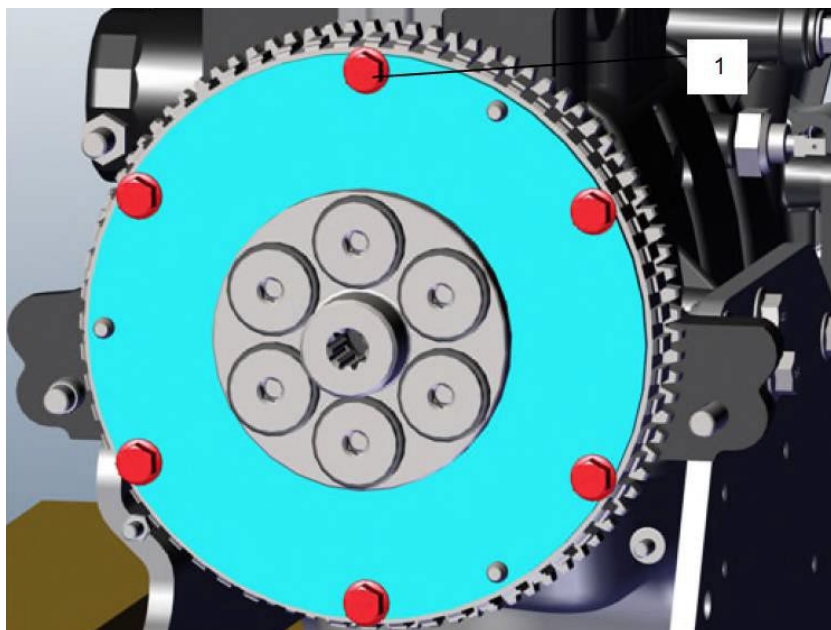

- 1) Remove 6 flex plate mounting bolts (1).
- 2) Remove flex plate from flywheel.

Flex Plate Installation

- 1) Install flex plate to flywheel using 6 flex plate mounting bolts (1).
- 2) Torque flex plate mounting bolts to 30 ft/lbs.

Engine Mount Removal

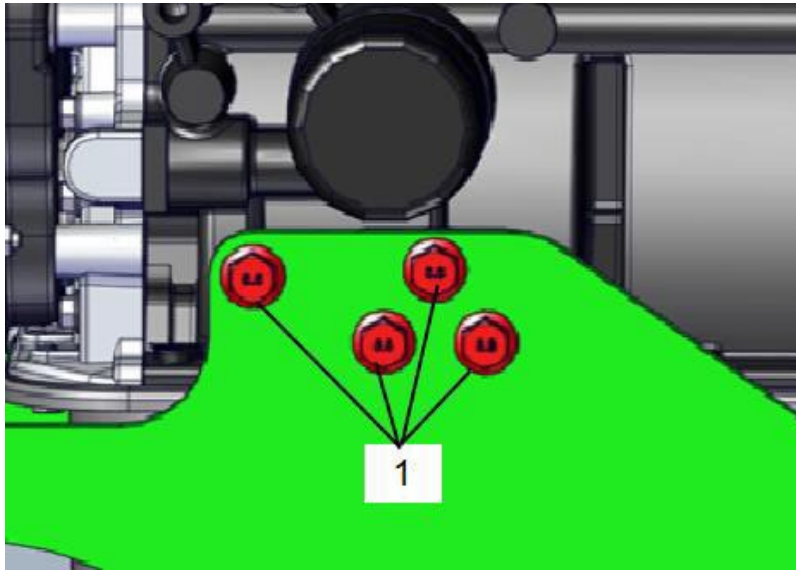

- 1) Remove right side engine mount bolts (1).
- 2) Remove right side engine mount.

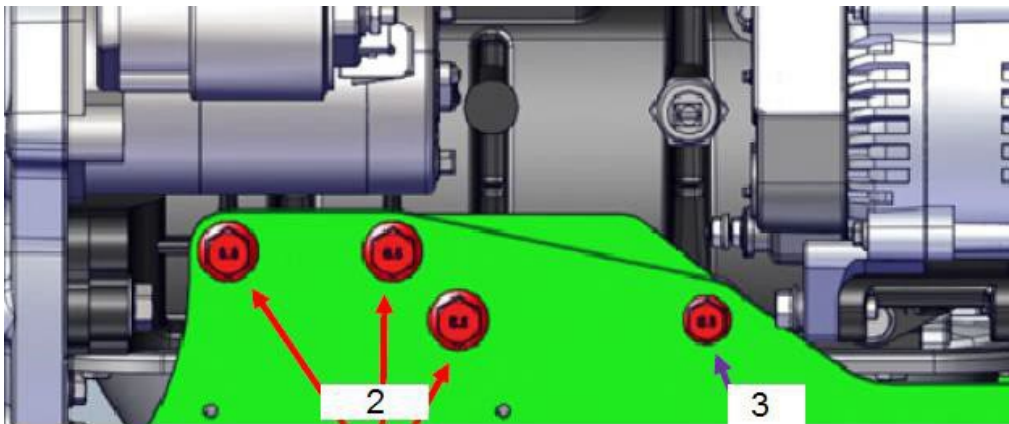

- 3) Remove left side engine mount bolts (2 & 3).
- 4) Remove left side engine mount.

Engine Mount Installation

- 1) Install left side engine mount using engine mount bolts (2 & 3).
- 2) Torque left side engine mount bolts to 30 ft/lbs.
- 3) Install right side engine mount using engine mount bolts (1).
- 4) Torque right side engine mount bolts to 30 ft/lbs.

Exhaust Manifold Removal

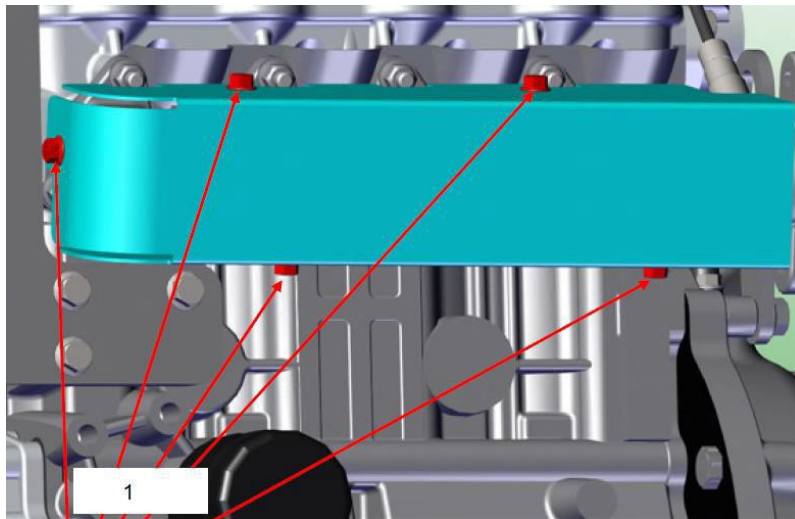

- 1) Remove exhaust shield mounting bolts (1) from exhaust manifold.
- 2) Remove exhaust manifold.

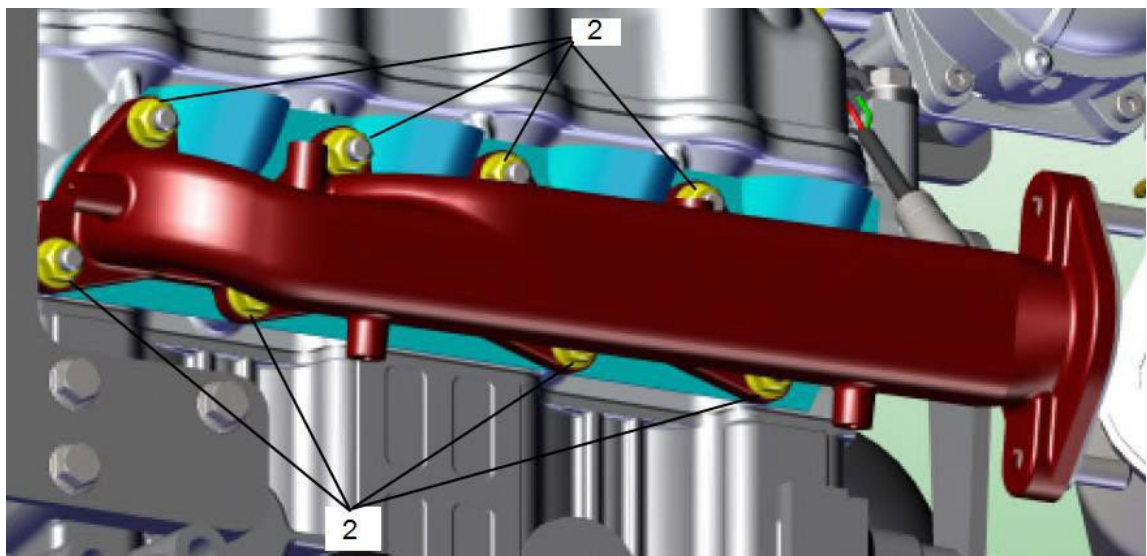

- 3) Remove exhaust manifold mounting bolts (2) from exhaust manifold.
- 4) Remove exhaust manifold.

Exhaust Manifold Installation

- 1) Install exhaust manifold using exhaust manifold mounting bolts (2).
- 2) Torque exhaust manifold mounting bolts to 18 ft/lbs.
- 3) Install exhaust shield on to exhaust manifold using exhaust shield mounting bolts (1).

Cylinder Head Bolt Torque Tightening Sequence

The tightening sequence of the cylinder head connecting bolts is shown in the diagram below. Tighten the bolts in this sequence to the specified torque values (tighten in two stages).

The torque specification for the cylinder head connecting bolts.
--

55~60N·m

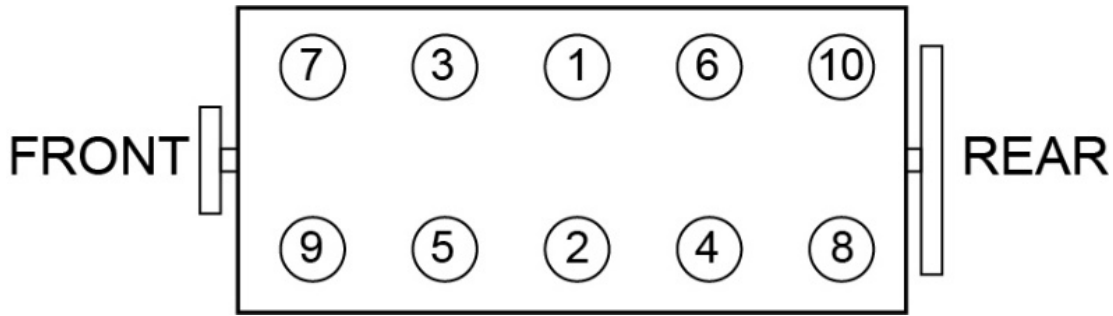

Spark Plug Wire Removal

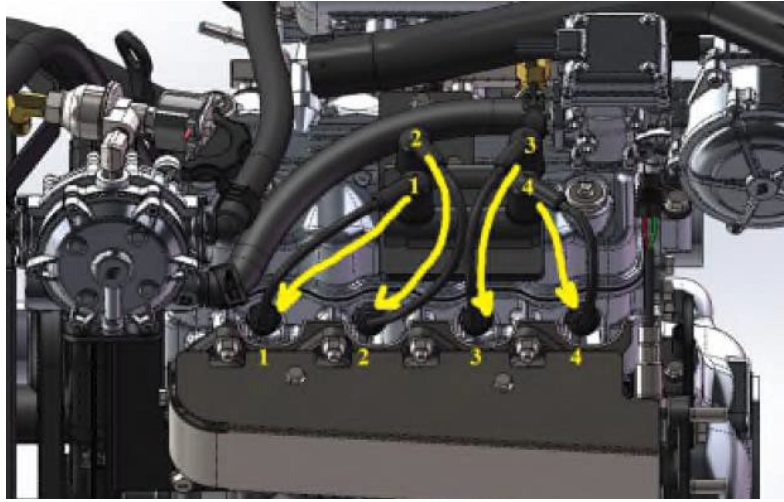

- 1) Remove spark plug wires from each cylinder.
- 2) Remove spark plug wires from ignition coil.

Spark Plug Wire Installation

- 1) Reference image for correct position of spark plug wires.
- 2) Install spark plug wires from ignition coil into their corresponding cylinder.

REQUIRED PREVENTATIVE MAINTANCE SCHEDULE

Perform the following maintenance on the engine at the hours indicated and at equivalent hour intervals thereafter.								
	Interval Hours							
	Daily	35	100	200	400	800	2000	As Req.
General Maintenance Section								
Visual check for fluid leaks	X							
Check engine oil level	X							
Check coolant level	X							
Change engine oil and filter	Every 150 hours or 120 days of operation							
Check LPG system for leaks	Prior to any service or maintenance activity							
Inspect accessory drive belts for cracks, breaks, splits or glazing			X		X		X	
Inspect electrical system wiring for cuts, abrasions or corrosion					X			
Inspect all vacuum lines and fittings for cracks, breaks or hardening					X			
PCV Valve				Clean		Replace		
Engine Coolant Section								
Clean debris from radiator core	Every 100 hours or 60 days of operation							
Change coolant						X		
Inspect coolant hoses for cracks, swelling or deterioration			X		X		X	
Engine Ignition System								
Replace spark plugs			X		X		X	
Check spark plug wires for cuts abrasions or hardening						X		
Replace spark plug wires								X
Fuel System Maintenance								
Inspect air cleaner	Every 200 hours, or every 100 hours in dusty environment							
Replace filter element	Every 400 hours or as required in dusty environment							
Replace fuel filter					X			
Leak check fuel lines					X			
Check air induction for leaks					X			
Check manifold for vacuum leaks			X		X		X	
Drain Vaporizer oil build up	Every engine oil change							
Engine								
Cylinder Head Bolt Torque -- 40.5 ft/lbs		X			X			
Timing Belt				Inspect			Replace	
Intake / Exhaust Valve Clearance Adjustment		X			X			
Check All bolts and nuts for tightness								X

LPG Fuel System

MOBILE ENGINE LPG FUEL SYSTEM SCHEMATIC

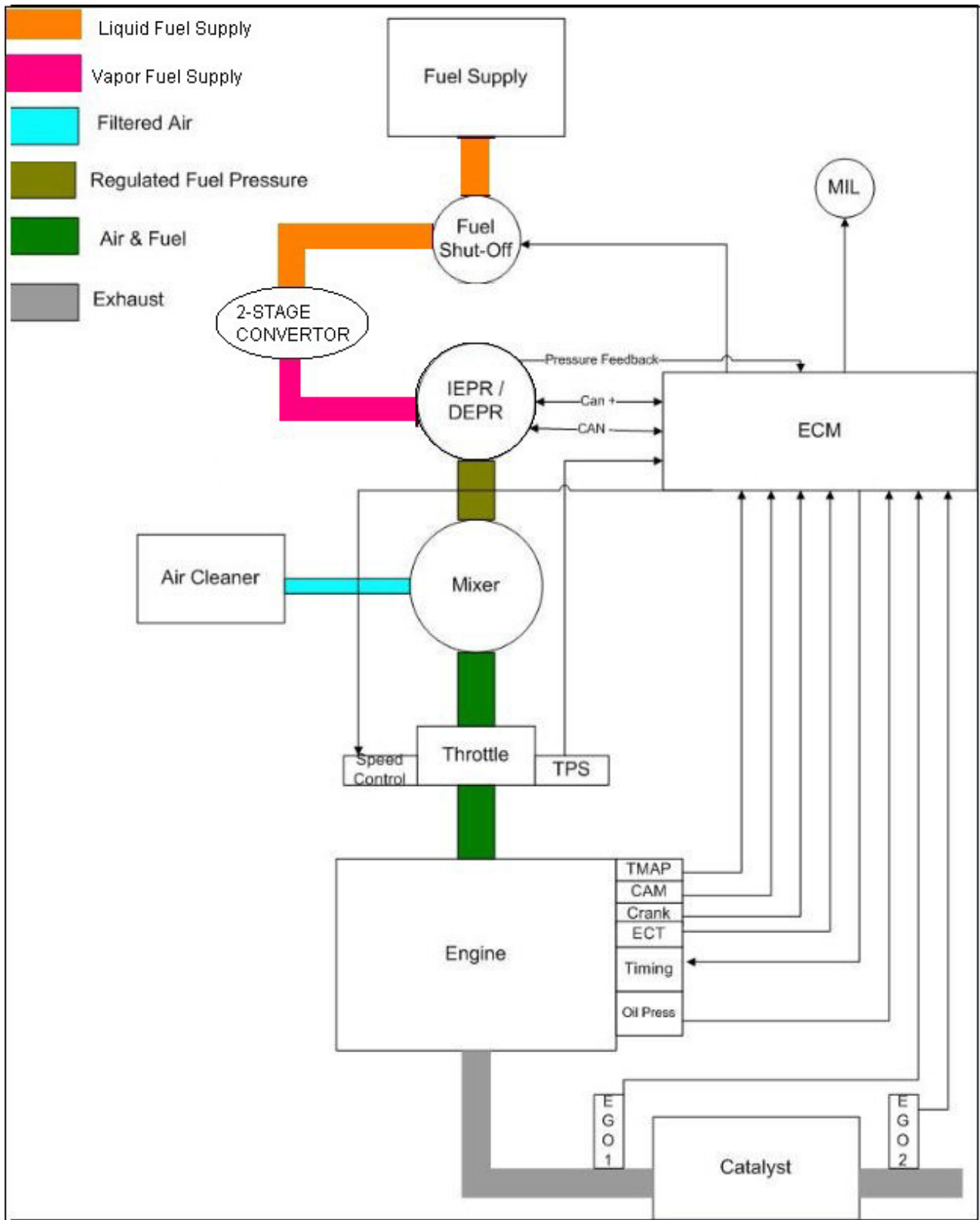

DESCRIPTION AND OPERATION OF THE FUEL SYSTEMS

LPL FUEL SYSTEM

The primary components of the fuel system are the fuel supply, fuel mixer, electronic throttle control (ETC) device, Dual Stage Regulator (DSR), engine control module (ECM/GCP), electric fuel lock-off valve, 3-Way Trim Valve, and a catalytic converter. The system operates on negative fuel pressure. Primary fuel pressure can be measured at the LD 2-Stage convertor. Secondary fuel pressure can be measured by using a "T" fitting installed in the fuel vapor line from the DSR to the fuel inlet at the mixer.

Description	Approx. Pressure
Nominal Primary Stage	3.2psi
Nominal Secondary (Final) Stage	1.5" H2O Below Atmospheric pressure
Maximum Inlet	250psi

SERVICE LINES

Fuel flows from the fuel supply to the electric lock off valve. The service lines are not supplied by the engine manufacturer. Please contact the equipment manufacturer regarding fuel service lines

FUEL FILTER

LP, fuel like all other motor fuels is subject to contamination from outside sources. Refueling of the equipment tank and removal of the tank from the equipment can inadvertently introduce dirt and other foreign matter into the fuel system. It is therefore necessary to filter the fuel prior to entering the fuel system components downstream of the tank. An in-line fuel filter has been installed in the fuel system to remove the dirt and foreign matter from the fuel, which is replaceable as a unit only. Maintenance of the filter is critical to proper operation of the fuel system and should be replaced according to the maintenance schedule or more frequently under severe operating conditions.

Inline Fuel Filter

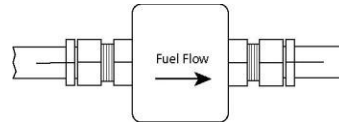

ELECTRIC FUEL LOCK-OFF VALVE

The Electric Fuel lock-off valve is an integrated assembly consisting of a 12 volt solenoid and a normally closed valve. When energized, the solenoid opens the valve and allows the fuel to flow through the device. The valve opens during cranking and engine run cycles. This device is ground side controlled by the ECM. Positive Voltage to the Electric Lock-Off Valve is controlled by the engine control module (ECM).

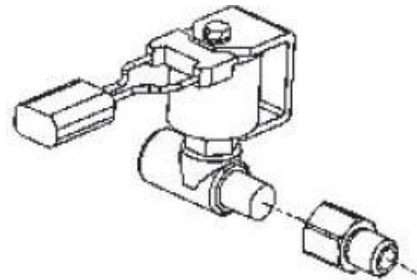

ELECTRIC FUEL LOCK-OFF

DIRECT ELECTRONIC PRESSURE REGULATOR (DEPR)

The ECI engine management system uses the DEPR to control fuel delivery for the precise fuel metering necessary for optimum combustion, fuel economy and transient response. The DEPR is available in either a 19 or a 28 mm size.

The DEPR is a single-stage microprocessor based electromechanical fuel pressure regulator that incorporates a high speed/fast acting actuator. It communicates with the Engine Control Module (ECM) over a Controller Area Network (CAN) link, receiving fuel pressure commands and broadcasting DEPR operating parameters back to the ECM.

The DEPR can regulate fuel pressure from -18 to +13 inches of water column above the Mixer air inlet pressure, providing sufficient control authority to stall an engine either rich or lean. When the DEPR receives an output pressure command from the ECM, the valve is internally driven to attain targeted fuel pressure, the DEPR then closes the loop internally using a built in fuel pressure sensor to maintain target fuel pressure/fuel flow rate, until another external command from the ECM is received (intervals < 10 ms). The DEPR has an integral fuel temperature sensor that is used by the ECM to correct for variations in fuel density. This strategy provides an extremely accurate method for open loop fuel control. Then with the addition of the pre- and post-cat oxygen sensors, the pressure command transmitted from the ECM can be further adjusted using closed loop feedback



Direct Electronic Pressure Regulator

	<h2>CAUTION</h2>
<p>The IEPR is an emission control device and should only be serviced by qualified technicians.</p>	

AIR FUEL MIXER



Air Valve Mixer

The air valve mixer is a self-contained air-fuel metering device. The mixer is an air valve design, utilizing a relatively constant pressure drop to draw fuel into the mixer from cranking speeds to full load. The mixer is mounted in the air stream ahead of the throttle control device.

When the engine begins to crank it draws in air with the air valve covering the inlet, and negative pressure begins to build. This negative pressure signal is communicated to the top of the air valve chamber through vacuum ports in the air valve assembly. A pressure/force imbalance begins to build across the air valve diaphragm between the air valve vacuum chamber and the atmospheric pressure below the diaphragm. The vacuum being created is referred to as Air Valve Vacuum (AVV). As the air valve vacuum reaches the imbalance point, the air valve begins to lift against the air valve spring. The amount of AVV generated is a direct result of the throttle position. At low engine speed the air valve vacuum and the air valve position is low thus creating a small venturi for the fuel to flow. As the engine speed increases the AVV increases and the air valve is lifted higher thus creating a much larger venturi.

The mixer is equipped with a low speed mixture adjustment retained in a tamper proof housing. The mixer has been preset at the factory and should not require adjustment. In the event that the idle adjustment should need to be adjusted refer to the Fuel System Repair section of this manual.



CAUTION

The air/fuel mixer is an emission control device. Components inside the mixer are specifically calibrated to meet the engine's emissions requirements and should never be disassembled or rebuilt. If the mixer fails to function correctly, replace with an OEM replacement part.

Dual Stage Regulator (DSR)

The Tier 3 certified mobile products utilize a 2-stage vaporizer as part of the fuel system. The primary function of this part is to convert liquid LP fuel into a propane vapor. The vapor is then introduced into the mixer fuel inlet port. Converting the fuel from a liquid to a vapor is accomplished by passing the propane through a heat exchanger inside the convertor. Coolant flows through the convertor as part of the heat exchange process.

The DSR is a normally closed vaporizing fuel pressure regulator.

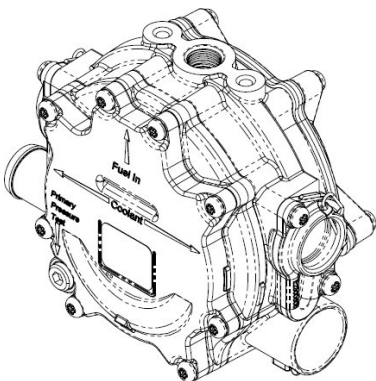

Dual Stage Regulator (DSR)

ELECTRONIC THROTTLE CONTROL DEVICE (ETC)—

Engine speed is controlled by the ECM and the Electronic Throttle Control device which is an automotive style throttle. The ECM controls engine speed one of several ways depending on the equipment manufacturer's requirement. Engine speed can be controlled by discrete speed governing, whereby the OEM sends an open, high or low voltage signal to an ECM pin. The ECM then targets the preprogrammed speed for that pin.

The other two modes are through the use of a foot pedal or a hand throttle controller. In both cases the foot pedal or hand throttle controller will send a 0-5 volt signal to the ECM. The ECM is programmed with an idle and high speed and interprets speed in between the two based on voltage.

When the engine is running electrical signals are sent from the foot pedal position sensor to the engine ECM when the operator depresses or release the foot pedal. The ECM then sends an electrical signal to the motor on the electronic throttle control to increase or decrease the angle of the throttle blade thus increasing or decreasing the air/fuel charge to the engine. The electronic throttle control device incorporates two internal Throttle Position Sensors (TPS) which provide output signals to the ECM as to the location of the throttle shaft and blade. The TPS information is used by the ECM to correct for speed and load control as well as emission.

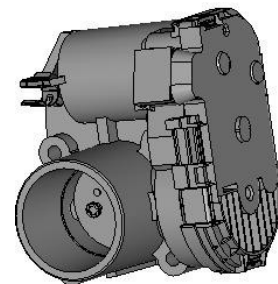

Electronic Throttle Control Device

IGNITION COIL



The ignition coil convert battery voltage into the high voltage that is needed to fire spark plugs and ignite fuel. This is a distributorless ignition system, which ignites two spark plugs at a time (1/4 and 2/3).

When the engine is running, the ECM determines ignition timing by monitoring engine load, engine RPM and engine coolant temperature.

THREE-WAY CATALYTIC CONVERTER

The Catalytic Converter is a component of the emissions system which is designed to meet the emission standards in effect for the Tier 3 mobile certified product.

The exhaust gases pass through the honeycomb catalyst which is coated with a mixture of precious group metals to oxidize and reduce CO, HC and NOX emission gases.

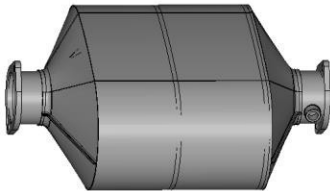

Three Way Catalytic Converter

ENGINE CONTROL MODULE

To obtain maximum effect from the catalyst and accurate control of the air fuel ratio, the emission certified engine is equipped with an onboard computer or Engine Control Module (ECM).

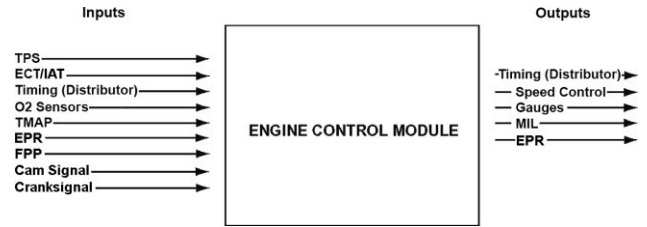

The ECM is a 32-bit controller which receives input data from sensors mounted to the engine and fuel system and then outputs various signals to control engine operation.



Engine Control Module (ECM)

One specific function of the controller is to maintain a closed loop fuel control which is accomplished by use of the Heated Exhaust Gas Oxygen sensor (HEGO) mounted in the exhaust system. The HEGO sensor sends a voltage signal to the controller which then outputs signals to the EPR to change the amount of fuel being delivered from the regulator or mixer to the engine.

The controller also performs diagnostic functions on the fuel system and notifies the operator of engine malfunctions by turning on a Malfunction Indicator Light (MIL) mounted in the dash. Malfunctions in the system are identified by a Diagnostic Trouble Code (DTC) number. In addition to notifying the operator of the malfunction in the system, the controller also stores the information about the malfunction in its memory. A technician can than utilize a computerized diagnostic scan tool to retrieve the stored diagnostic code and by using the diagnostic charts in this manual to determine the cause of the malfunction. In the event a technician does not have the

computerized diagnostic tool, the MIL light can be used to identify the diagnostic code to activate the “blink” feature and count the number of blinks to determine the diagnostic code number to locate the fault in the system. The .97L Engine is equipped with either the 90-Way GCP ECM module or the 56-Way ECM Module, depending on equipment manufacture.

HEATED EXHAUST GAS OXYGEN SENSOR



The Heated Exhaust Gas Oxygen (HEGO) Sensor is mounted in the exhaust system before the catalytic muffler.

The HEGO sensors are used to measure the amount of oxygen present in the exhaust stream to determine whether the air-fuel ratio is too rich or too lean. It then communicates this measurement to the ECM. If the HEGO sensor signal indicates that the exhaust stream is too rich, the ECM will decrease or lean the fuel mixture during engine operation. If the mixture is too lean, the ECM will richen the mixture. If the ECM determines that a rich or lean condition is present for an extended period of time which cannot be corrected, the ECM will set a diagnostic code and turn on the MIL light in the dash.

EXAMPLE OF GOOD O2 SENSOR PATTERN IS SHOWN BELOW

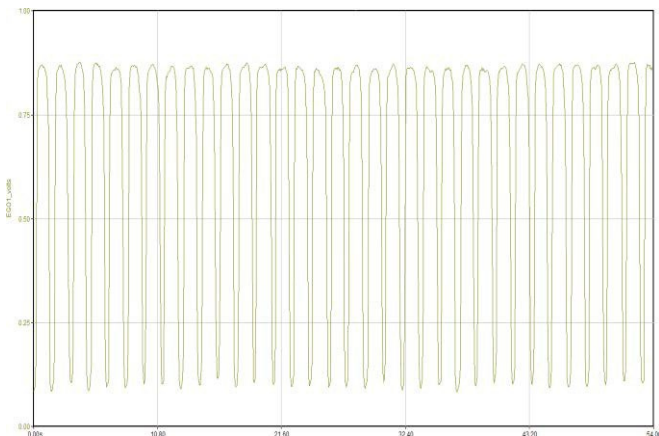

⚠ CAUTION

The Heated Exhaust Gas Oxygen Sensor (HEGO) is an emissions control component. In the event of a failure, the HEGO should only be replaced with the recommended OEM replacement part. The HEGO is sensitive to silicone based products and can become contaminated. Avoid using silicone sealers or air or fuel hoses treated with a silicone based lubricant.

CLOSED LOOP FUEL CONTROL

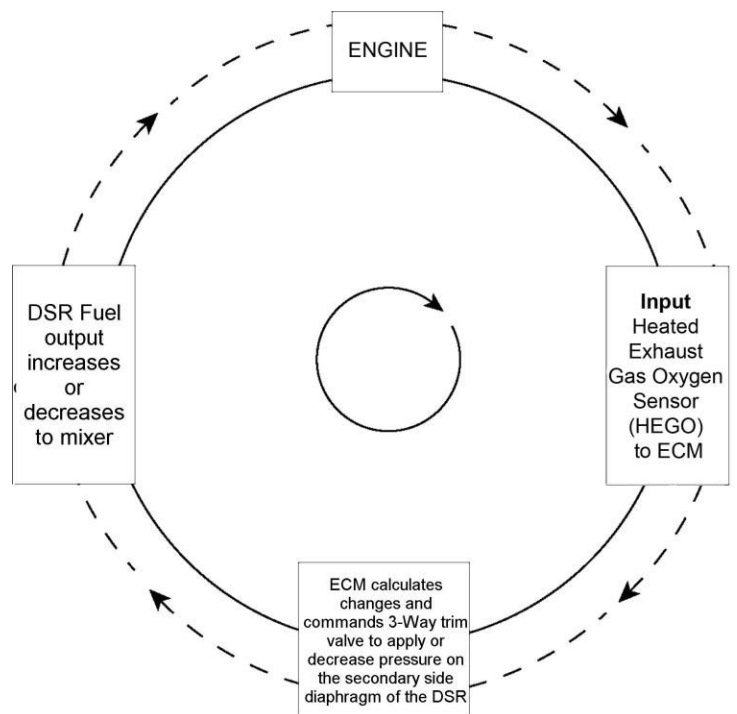

LD 2-Stage Regulator Nominal Pressure Specifications

Secondary Stage	15.25 ±10 inches H2O
Primary Stage	2.6 ±1.45PSI

TMAP SENSOR

The Temperature Manifold Absolute Pressure or TMAP sensor is a variable resistor used to monitor the difference in pressure between the intake manifold and outside or atmospheric pressure and the temperature. The ECM monitors the resistance of the sensor to determine engine load (the vacuum drops when the engine is under load or at wide open throttle). When the engine is under load, the computer may alter the fuel mixture to improve performance and emissions. The temperature is also monitored by the ECM, primarily to richen the fuel/air mixture during a cold start.

COOLANT TEMPERATURE SENSOR

The Engine Coolant Temperature sensor or ECT is a variable resistance thermistor that changes resistance as the engine's coolant temperature changes. The sensor's output is monitored by the ECM to determine a cold start condition and to regulate various fuel and emission control functions via a closed loop emission system.

OIL PRESSURE SENDER

The Engine Oil Pressure sensor is designed to ensure adequate lubrication throughout the engine. It provides a pressure value for the oil pressure gauge and is monitored by the ECM. If the pressure drops, an MIL will occur.

Gasoline Fuel System

GASOLINE FUEL SYSTEM SCHEMATIC

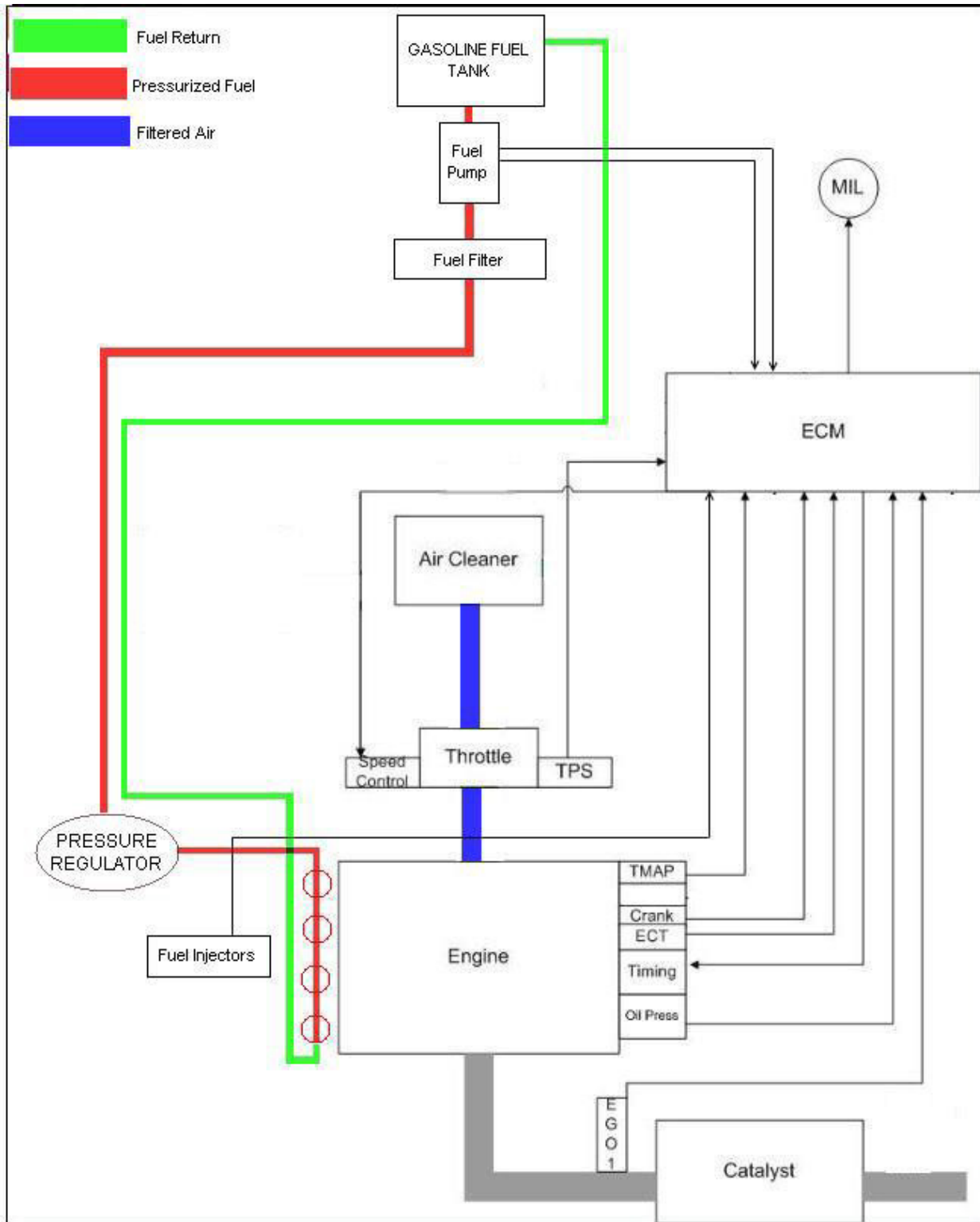

GASOLINE MULTI POINT FUEL INJECTION (MPFI)

The primary components of the Gasoline Multi Point Fuel Injection (MPFI) fuel system are the gasoline fuel tank, electric fuel pump, fuel pressure regulator, fuel filter, fuel injectors, and fuel rail.

GASOLINE FUEL STORAGE TANK

The gasoline fuel storage tank location may vary on equipment applications. The fuel tank may be integrated into the chassis frame or may be a standalone vessel mounted on the equipment. For precise location for the equipment application refer to the OEM's vehicle manual.

GASOLINE FUEL PUMP

The Gasoline is stored as a liquid in the fuel tank and is drawn into the fuel system by a 12 volt electric fuel pump. Depending on the vehicle application the fuel pump may be mounted in the fuel tank or as a stand alone component. In either case the fuel pump will receive a signal from the ECM at Key On to prime the fuel system for approximately 2 seconds prior to start. Priming of the fuel system provides for a quicker start, when the engine begins to crank. Consult the OEM for the location of the fuel pump.

GASOLINE FUEL PRESSURE REGULATOR

The fuel flows from the fuel filter to the fuel regulator, then to the fuel rail.

To make a fuel pressure adjustment, a T-fitting must be placed in-line between the regulator and the fuel rail with a pressure gauge attached to the T-fitting to measure the fuel pressure. With the engine running, loosen the jam nut, then turning the adjustment screw, adjust the pressure till the reading shows 43.5 psi. Secure the adjustment screw by tightening the jam nut. Shut off the engine, and remove the T-fitting and re-attach the fuel line from the fuel rail to the regulator. **Note the fuel pressure must be removed before and after to safely install/remove the t-fitting.**

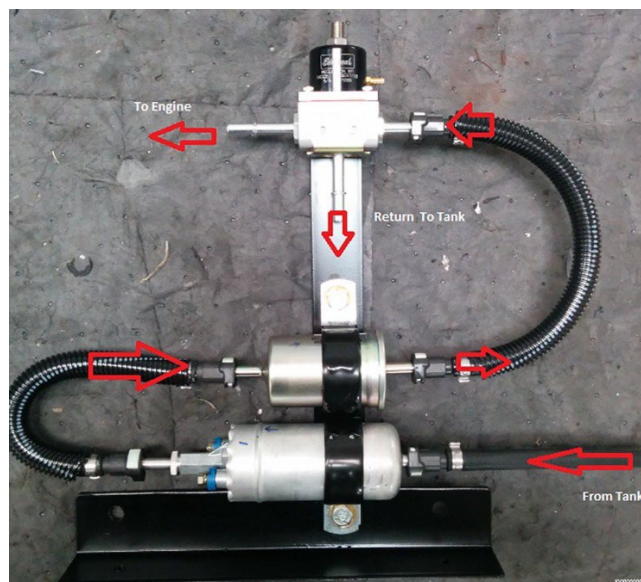
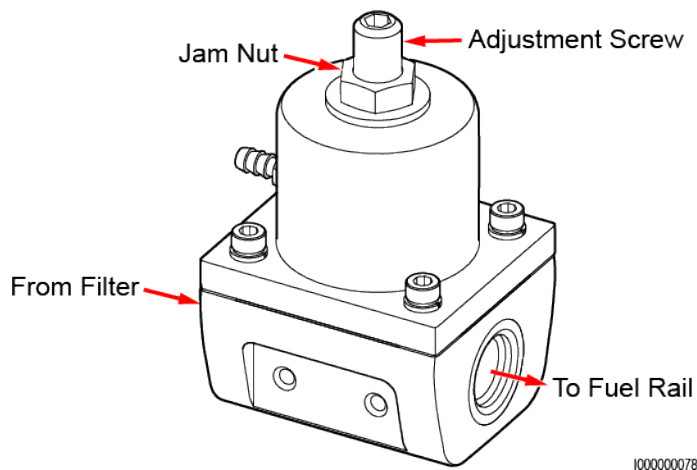

FUEL FILTER

After the fuel is drawn into the fuel pump, the fuel flows through the gasoline fuel filter. The fuel filter will trap small particles. The fuel passes through the filter to remove debris which prevents the fuel pressure and temperature manifold and fuel injectors from becoming damaged. Maintenance of the fuel filter is required as indicated in the *Recommended Maintenance Schedule*. A more frequent replacement of the filter may be required if the equipment operates in a dusty or dirty environment.

FUEL INJECTOR RAIL

The fuel flows from the fuel pressure regulator through the fuel rail where the fuel is delivered to the fuel injectors.

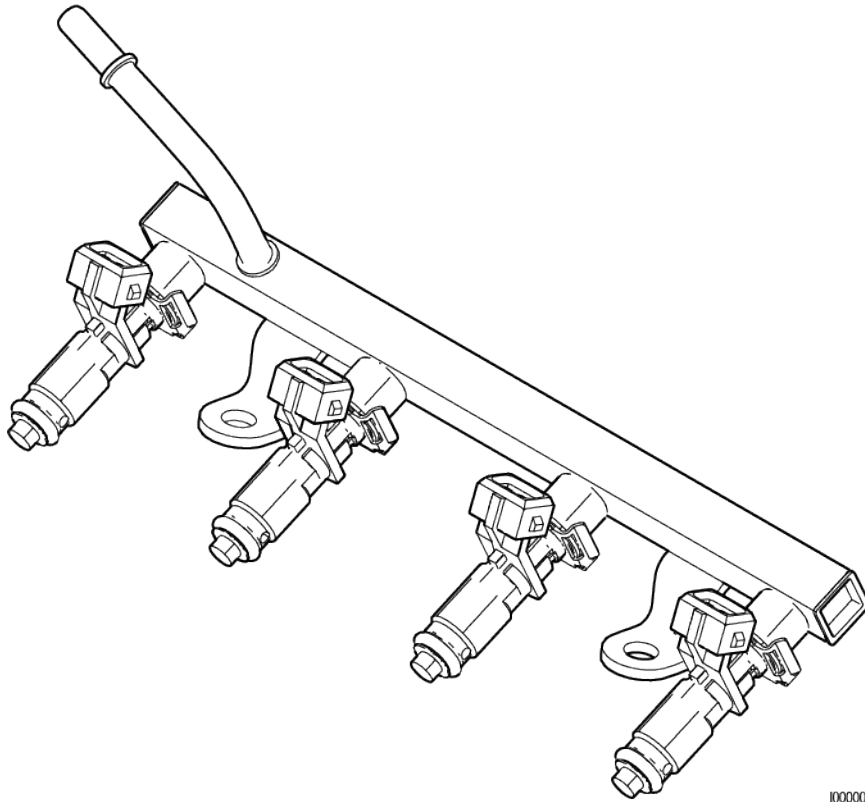

100000079

FUEL INJECTOR

The fuel supply is maintained on the top of the injector from the injector rail. The injector is fed a “pulse” signal through the wire harness which causes the injector to open. During regular operating conditions the ECM controls the opening and duration of opening of the injector. During lower RPM operation the injector signals or “pulses” are less frequent than when the engine is operating at higher RPMs. The certified engine has been calibrated to deliver the precise amount of fuel for optimum performance and emission control.



Closed Loop Control - Gasoline

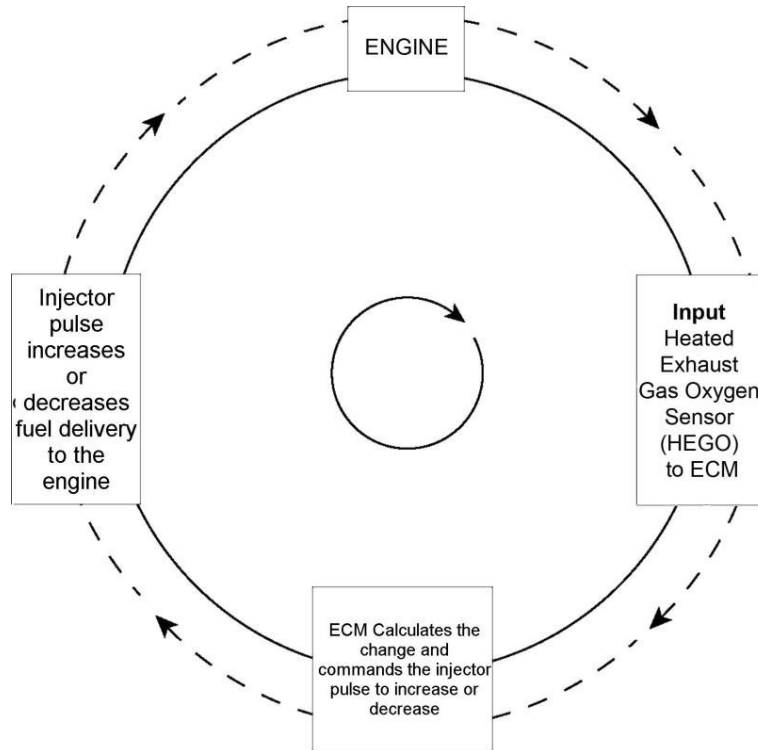

Fuel System Diagnosis

FUEL SYSTEM DIAGNOSIS



Direct Electronic Pressure Regulator Assembly

FUEL SYSTEM DESCRIPTION

The Engine Control Module (ECM) receives information from various engine sensors in order to control the operation of the Direct Electronic Pressure Regulator (DEPR) and lock-off Valve. The lock-off Valve solenoid prevents fuel flow unless the engine is cranking or running.

At Key ON, the DEPR valve receives a two (2) second prime pulse from the ECM, allowing time for the fuel to flow through the fuel filter and fuel lines to the DEPR.

Fuel travels from the lock-off to the light duty 2- stage regulator into the DEPR.

Engine cranking generates vacuum which provides lift for the mixer air valve and is commonly referred to as air valve vacuum. Once in the mixer, the fuel is combined with air and is drawn into the engine for combustion.

DIAGNOSTIC AIDS

This procedure is intended to diagnose equipment operating on LPG. If the equipment will not continue to run, refer to Hard Start for preliminary checks.

- Inspect the fuel supply lines to verify they are properly connected and do not have any kinks or damage
- Verify the fuel lock off valve is operating properly. Refer to the OEM for information on the fuel shut off valve.

TOOLS REQUIRED:

DST

- Diagnostic Service Tool (DST)

PRESSURE GAUGES

- ITK-2 Test Kit

TEST DESCRIPTION

The basis of the fuel system test is to determine if the fuel is operating within proper fuel control parameters. This fuel control system operates on the basis of short term and long term fuel correction to compensate for the normal operation and aging of the engine. Abnormal operation of the engine, due to a component issue or lack of maintenance will cause fuel system control parameters to operate outside of the normal range.

The fuel system correction factors are viewable using the laptop based Diagnostic Service Tool (DST).

The short term correction factor is a percentage based fuel correction that will immediately be applied once the engine reaches the closed loop fuel control mode. The short term correction factor is known as "Closed Loop 1" on the DST.

The long term correction factor writes the short term correction into long term memory so it is available immediately on the next start/run cycle. The long term correction factor is known as "Adaptive 1" on the DST.

Closed Loop 1 and Adaptive 1 can be viewed on the Closed Loop Control panel on the Faults Page of the DST.

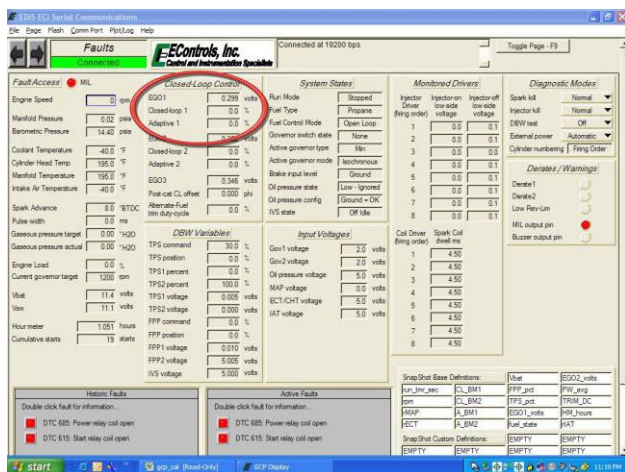

Closed Loop 1 & Adaptive 1

Any parameter found to be out of conformance will require additional diagnosis.

HOW THE CORRECTION FACTORS WORK

The correction factors are displayed in the DST as a positive or negative percent. The numbers will range between -35% and +35%. A negative fuel correction number indicates the removal of fuel.

An outside condition causing the system to be rich, such as a restricted air cleaner, can cause a negative short term and long term fuel correction. An outside condition causing the system to be lean, such as a vacuum leak, can cause a positive fuel correction.

DETERMINING TOTAL FUEL CORRECTION

The total fuel correction is the sum of the short term correction (Closed Loop 1) and the long term correction (Adaptive 1).

For instance, a Closed Loop 1 reading of -1.5% and an Adaptive 1 reading of -3.5% would mean a total fuel correction of -5% was taking place at that time. The system is removing 5% fuel at that time.

A Closed Loop 1 reading of 1.5% and an Adaptive 1 reading of 3.5% (note both are positive numbers) would mean that a total fuel correction of 5% was taking place at that time. The system is adding 5% fuel.

NORMAL & ABNORMAL FUEL CORRECTION

Generally, the system is operating within specification when total fuel correction falls between - 15% and +15%. Operation outside of this range will require further diagnosis to determine the system level issue affecting fuel control. The system will set Diagnostic Trouble Codes (DTC's) for correction factors in the +/- 30%-35% range.

If total fuel correction is found to be operating outside of the normal range additional diagnostic procedure will be required to determine the cause. Follow the appropriate Symptom Routine or DTC Chart for additional help.

Total Fuel Correction Chart

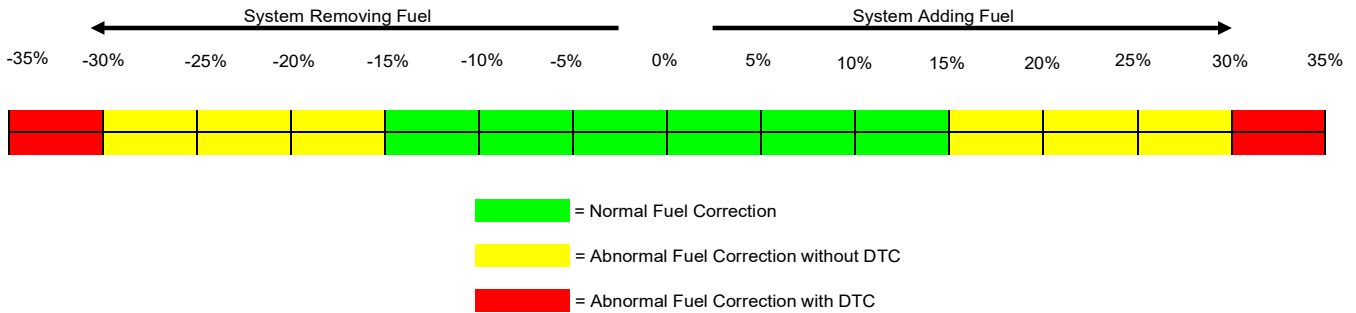

LPG FUEL PRESSURE SPECIFICATION

Description	Approx. Pressure
Nominal Primary Stage	3.2psi
Nominal Secondary (Final) Stage	1.5" H2O Below Atmospheric pressure
Maximum Inlet	250psi

FUEL SYSTEM SYMPTOM DIAGNOSTICS

Checks	Action
Before Using This Section	<p>Before using this section, you should have performed On Board Diagnostic (OBD) Check and determined that:</p> <ol style="list-style-type: none"> 1. The ECM and MIL are operating correctly. 2. There are no Diagnostic Trouble Codes (DTCs) stored, or a DTC exists but without a MIL. <p>Several of the following symptom procedures call for a careful visual and physical check. These checks are very important as they can lead to prompt diagnosis and correction of a problem.</p>
Fuel System Check	<ol style="list-style-type: none"> 1. Verify the customer complaint. 2. Locate the correct symptom table. 3. Check the items indicated under that symptom. 4. Operate the equipment under the conditions the symptom occurs. Verify HEGO switching between lean and rich. IMPORTANT! Normal HEGO switching indicates the fuel system is in closed loop and operating correctly at that time. 5. Take a data snapshot using the DST under the condition that the symptom occurs to review at a later time.
Visual and Physical Checks	<ul style="list-style-type: none"> • Check all ECM system fuses and circuit breakers. • Check the ECM ground for being clean, tight and in its proper location. • Check the vacuum hoses for splits, kinks and proper connections. • Check thoroughly for any type of leak or restriction. • Check for air leaks at all the mounting areas of the intake manifold sealing surfaces. • Check for proper installation of the mixer assembly. • Check for air leaks at the mixer assembly. <p>Check the ignition wires for the following conditions:</p> <ul style="list-style-type: none"> • Cracking • Hardening • Proper routing • Carbon tracking. <ul style="list-style-type: none"> • Check the wiring for the following items: proper connections, pinches or cuts. • The following symptom tables contain groups of possible causes for each symptom. The order of these procedures is not important. If the DST readings do not indicate a problem, then proceed in a logical order, easiest to check or most likely to cause the problem.

INTERMITTENT

Checks	Action
<p>DEFINITION: The problem may or may not turn ON the (MIL) or store a Diagnostic Trouble Code (DTC).</p>	
Preliminary Checks	<p>Do not use the DTC tables. If a fault is an intermittent, the use of the DTC tables with this condition may result in the replacement of good parts.</p>
Faulty Electrical Connections or Wiring	<p>Faulty electrical connections or wiring can cause most intermittent problems. Check the suspected circuit for the following conditions:</p> <ul style="list-style-type: none"> • Faulty fuse or circuit breaker, connectors poorly mated, terminals not fully seated in the connector (backed out). Terminals not properly formed or damaged. • Wire terminals poorly connected. • Terminal tension is insufficient. • Carefully remove all the connector terminals in the problem circuit in order to ensure the proper contact tension. • If necessary, replace all the connector terminals in the problem circuit in order to ensure the proper contact tension (except those noted as “Not Serviceable”). See section <i>Wiring Schematics</i>. • Checking for poor terminal to wire connections requires removing the terminal from the connector body.
Operational Test	<p>If a visual and physical check does not locate the cause of the problem, operate the vehicle with the DST connected. When the problem occurs, an abnormal voltage or scan reading indicates a problem circuit.</p>
Intermittent MIL Illumination	<p>The following components can cause intermittent MIL and no DTC(s):</p> <ul style="list-style-type: none"> • A defective relay. • Switch that can cause electrical system interference. Normally, the problem will occur when the faulty component is operating. • The improper installation of add on electrical devices, such as lights, 2-way radios, electric motors, etc. • The ignition secondary voltage shorted to a ground. • The MIL circuit or the Diagnostic Test Terminal intermittently shorted to ground. • The MIL wire grounds.
Loss of DTC Memory	<p>To check for the loss of the DTC Memory:</p> <ol style="list-style-type: none"> 1. Disconnect the TMAP sensor. 2. Idle the engine until the MIL illuminates. 3. The ECM should store a TMAP DTC which should remain in the memory when the ignition is turned OFF. If the TMAP DTC does not store and remain, the ECM is faulty.

NO START

Checks	Action
DEFINITION: <i>The engine cranks OK but does not start.</i>	
Preliminary Checks	None
ECM Checks	<p>Use the DST to :</p> <ul style="list-style-type: none"> • Check for proper communication with both the ECM • Check all system fuses engine fuse holder. Refer to <i>Engine Controls Schematics</i>. • Check battery power, ignition power and ground circuits to the ECM. Refer to <i>Engine Control Schematics</i>. Verify voltage and/or continuity for each.
Sensor Checks	<ul style="list-style-type: none"> • Check the TMAP sensor. • Check the cam angle sensor for output (RPM).
Fuel System Checks	<p>Important: A closed LPG manual fuel shut off valve will create a no start condition.</p> <ul style="list-style-type: none"> • Check for air intake system leakage between the mixer and the throttle body. Verify proper operation of the low pressure lock-off solenoids. • Verify proper operation of the fuel control solenoids. • Check the fuel system pressures. • Refer to the <i>LPG Fuel System Diagnosis</i>. • Check for proper mixer air valve operation.
Ignition System Checks	<p>Note: LPG being a gaseous fuel requires higher secondary ignition system voltages for the equivalent gasoline operating conditions.</p> <ol style="list-style-type: none"> 1. Check for the proper ignition voltage output with <i>J 26792</i> or the equivalent. 2. Verify that the spark plugs are correct for use with LPG. <p>Check the spark plugs for the following conditions:</p> <ul style="list-style-type: none"> • Wet plugs. • Cracks. • Wear. • Improper gap. • Burned electrodes. • Heavy deposits. • Check for bare or shorted ignition wires. • Check for loose ignition coil connections at the coil.

NO START

Checks	Action
Engine Mechanical Checks	<p>Important: The LPG Fuel system is more sensitive to intake manifold leakage than the gasoline fuel system.</p> <p>Check for the following:</p> <ul style="list-style-type: none"> • Vacuum leaks. • Improper valve timing. • Low compression. • Improper valve clearance. • Worn rocker arms. • Broken or weak valve springs. <p>Worn camshaft lobes.</p>
Exhaust System Checks	<p>Check the exhaust system for a possible restriction:</p> <ul style="list-style-type: none"> • Inspect the exhaust system for damaged or collapsed pipes: • Inspect the muffler for signs of heat distress or for possible internal failure. • Check for possible plugged catalytic converter. Refer to <i>Restricted Exhaust System Diagnosis</i>.

HARD START

Checks	Action
<p>DEFINITION: The engine cranks OK, but does not start for a long time. The engine does eventually run, or may start but immediately dies.</p>	
Preliminary Checks	Make sure the vehicle's operator is using the correct starting procedure.
Sensor Checks	<ul style="list-style-type: none"> • Check the Engine Coolant Temperature sensor with the DST. Compare the engine coolant temperature with the ambient air temperature on a cold engine. If the coolant temperature reading is more than 10 degrees greater or less than the ambient air temperature on a cold engine, check for high resistance in the coolant sensor circuit. Check the cam angle sensor. • Check the Throttle Position (TPS) and Foot Pedal Position (FPP) sensor connections.
Fuel System Checks	<p>Important: A closed LPG manual fuel shut off valve will create an extended crank OR no start condition.</p> <ul style="list-style-type: none"> • Verify the excess flow valve is not tripped or that the manual shut-off valve is not closed. <p>Check mixer assembly for proper installation and leakage.</p> <ul style="list-style-type: none"> • Verify proper operation of the low pressure lock-off solenoid. • Verify proper operation of the EPR. • Check for air intake system leakage between the mixer and the throttle body. Check the fuel system pressures. Refer to the <i>Fuel System Diagnosis</i>.
Ignition System Checks	<p>Note: LPG being a gaseous fuel requires higher secondary ignition system voltages for the equivalent gasoline operating conditions.</p> <ul style="list-style-type: none"> • Check for the proper ignition voltage output with J 26792 or the equivalent. • Verify that the spark plugs are the correct type and properly gapped. <p>Check the spark plugs for the following conditions:</p> <ul style="list-style-type: none"> • Wet plugs. • Cracks. • Wear. • Burned electrodes. • Heavy deposits • Check for bare or shorted ignition wires. • Check for moisture in the distributor cap. • Check for loose ignition coil connections. <p>Important:</p> <ol style="list-style-type: none"> 1. If the engine starts but then immediately stalls, check the cam angle sensor. 2. Check for improper gap, debris or faulty connections.

HARD START

Checks	Action
Engine Mechanical Checks	<p>Important: The LPG Fuel system is more sensitive to intake manifold leakage than the gasoline fuel supply system.</p> <p>Check for the following:</p> <ul style="list-style-type: none"> • Vacuum leaks • Improper valve timing • Low compression • Improper valve clearance. • Worn rocker arms • Broken or weak valve springs • Worn camshaft lobes. <p>Check the intake and exhaust manifolds for casting flash.</p>
Exhaust System Checks	<p>Check the exhaust system for a possible restriction:</p> <ul style="list-style-type: none"> • Inspect the exhaust system for damaged or collapsed pipes. • Inspect the muffler for signs of heat distress or for possible internal failure. <p>Check for possible plugged catalytic converter. Refer to <i>Restricted Exhaust System Diagnosis</i>.</p>

CUTS OUT, MISSES

Checks	Action
<p>DEFINITION: A surging or jerking that follows engine speed, usually more pronounced as the engine load increases, but normally felt below 1500 RPM. The exhaust has a steady spitting sound at idle, low speed, or hard acceleration for the fuel starvation that can cause the engine to cut-out.</p>	
Preliminary Checks	None
Ignition System Checks	<ol style="list-style-type: none"> 1. Start the engine. 2. Check for proper ignition output voltage with spark tester J 26792. 3. Check for a cylinder misfire. 4. Verify that the spark plugs are the correct type and properly gapped. <p>Remove the spark plugs and check for the following conditions:</p> <ul style="list-style-type: none"> • Insulation cracks. • Wear. • Improper gap. • Burned electrodes. • Heavy deposits. <p>Visually/Physically inspect the secondary ignition for the following:</p> <ul style="list-style-type: none"> • Ignition wires for arcing and proper routing. • Cross-firing. • Ignition coils for cracks or carbon tracking
Engine Mechanical Checks	<p>Perform a cylinder compression check. Check the engine for the following:</p> <ul style="list-style-type: none"> • Improper valve timing. • Improper valve clearance. • Worn rocker arms. • Worn camshaft lobes. • Broken or weak valve springs. • Check the intake and exhaust manifold passages for casting flash.
Fuel System Checks	<p>Check the fuel system:</p> <ul style="list-style-type: none"> • Plugged fuel filter. • Low fuel pressure, etc. Refer to <i>LPG Fuel System Diagnosis</i>. • Check the condition of the wiring to the low pressure lock-off solenoid.
Additional Check	<p>Check for Electromagnetic Interference (EMI), which may cause a misfire condition. Using the DST, monitor the engine RPM and note sudden increases in rpms displayed on the scan tool but with little change in the actual engine rpm. If this condition exists, EMI may be present. Check the routing of the secondary wires and the ground circuit.</p>

HESITATION, SAG, STUMBLE

Checks	Action
<p>DEFINITION: <i>The engine has a momentary lack of response when putting it under load. The condition can occur at any engine speed. The condition may cause the engine to stall if it's severe enough.</i></p>	
Preliminary Checks	None.
Fuel System Checks	<ul style="list-style-type: none"> • Check the fuel pressure. Refer to <i>LPG Fuel System Diagnosis</i>. • Check for low fuel pressure during a moderate or full throttle acceleration. If the fuel pressure drops below specification, there is possibly a faulty low pressure regulator or a restriction in the fuel system. • Check the TMAP sensor response and accuracy. • Check Shut-Off electrical connection. • Check the mixer air valve for sticking or binding. • Check the mixer assembly for proper installation and leakage. Check the EPR.
Ignition System Checks	<p>Note: LPG being a gaseous fuel requires higher secondary ignition system voltages for the equivalent gasoline operating conditions. If a problem is reported on LPG and not gasoline, do not discount the possibility of a LPG only ignition system failure and test the system accordingly.</p> <ul style="list-style-type: none"> • Check for the proper ignition voltage output with <i>J 26792</i> or the equivalent. Verify that the spark plugs are the correct type and properly gapped. • Check for faulty spark plug wires. • Check for fouled spark plugs.
Additional Check	<ul style="list-style-type: none"> • Check for manifold vacuum or air induction system leaks. • Check the alternator output voltage.

BACKFIRE

Checks	Action
<p>DEFINITION: The fuel ignites in the intake manifold, or in the exhaust system, making a loud popping noise.</p>	
Preliminary Check	None.
Ignition System Checks	<p>Important! LPG, being a gaseous fuel, requires higher secondary ignition system voltages for the equivalent gasoline operating conditions. The ignition system must be maintained in peak condition to prevent backfire.</p> <ul style="list-style-type: none"> • Check for the proper ignition coil output voltage using the spark tester J26792 or the equivalent. • Check the spark plug wires by connecting an ohmmeter to the ends of each wire in question. If the meter reads over 30,000 ohms, replace the wires. • Check the connection at ignition coil. • Check for deteriorated spark plug wire insulation. <p>Remove the plugs and inspect them for the following conditions:</p> <ul style="list-style-type: none"> • Wet plugs. • Cracks. • Wear. • Improper gap. • Burned electrodes. • Heavy deposits.
Engine Mechanical Check	<p>Important! The LPG Fuel system is more sensitive to intake manifold leakage than a gasoline fuel supply system.</p> <p>Check the engine for the following:</p> <ul style="list-style-type: none"> • Improper valve timing. • Engine compression. • Manifold vacuum leaks. • Intake manifold gaskets. • Sticking or leaking valves. • Exhaust system leakage. • Check the intake and exhaust system for casting flash or other restrictions.
Fuel System Checks	Perform a fuel system diagnosis. Refer to <i>LPG Fuel System Diagnosis</i> .

LACK OF POWER, SLUGGISHNESS, OR SPONGINESS

Checks	Action
DEFINITION: <i>The engine delivers less than expected power.</i>	
Preliminary Checks	<ul style="list-style-type: none"> • Refer to the <i>LPG Fuel system OBD System Check</i>. • Compare the customer's vehicle with a similar unit to verify customer has an actual problem. <i>Do not compare the power output of the vehicle operating on LPG to a vehicle operating on gasoline as the fuels do have different drive feel characteristics.</i> • Remove the air filter and check for dirt or restriction. • Check the vehicle transmission. • Refer to the OEM transmission diagnostics.
Fuel System Checks	<ul style="list-style-type: none"> • Check for a restricted fuel filter, contaminated fuel, or improper fuel pressure. Refer to <i>LPG Fuel System Diagnosis</i>. • Check for the proper ignition output voltage with the spark tester <i>J 26792</i> or the equivalent. • Check for proper installation of the mixer assembly. Check all air inlet ducts for condition and proper installation. • Check for fuel leaks between the EPR and the mixer. • Verify that the LPG tank manual shut-off valve is fully open. • Verify that liquid fuel (not vapor) is being delivered to the EPR.
Sensor Checks	<ul style="list-style-type: none"> • Check the Heated Exhaust Gas Oxygen Sensors (HEGO) for contamination and performance. Check for proper operation of the TMAP sensor. • Check for proper operation of the TPS and FPP sensors.
Exhaust System Checks	<p>Check the exhaust system for a possible restriction:</p> <ul style="list-style-type: none"> • Inspect the exhaust system for damaged or collapsed pipes. • Inspect the muffler for signs of heat distress or for possible internal failure. • Check for possible plugged catalytic converter.
Engine Mechanical Check	<p>Check the engine for the following:</p> <ul style="list-style-type: none"> • Engine compression. • Valve timing. • Improper or worn camshaft. • Refer to <i>Engine Mechanical</i> in the Service Manual.
Additional Check	<ul style="list-style-type: none"> • Check the ECM grounds for being clean, tight, and in their proper locations. • Check the alternator output voltage. <p>If all procedures have been completed and no malfunction has been found, review and inspect the following items:</p> <ul style="list-style-type: none"> • Visually and physically, inspect all electrical connections within the suspected circuit and/or systems. • Check the DST data.

ROUGH, UNSTABLE, OR INCORRECT IDLE, STALLING

Checks	Action
<p>DEFINITION: The engine runs unevenly at idle. If severe enough, the engine may shake.</p>	
Preliminary Check	None.
Sensor Checks	<p>Check the Heated Exhaust Gas Oxygen Sensors (HEGO) performance:</p> <ul style="list-style-type: none"> • Check for silicone contamination from fuel or improperly used sealant. If contaminated, the sensor may have a white powdery coating result in a high but false signal voltage (rich exhaust indication). The ECM will reduce the amount of fuel delivered to the engine causing a severe drivability problem. <p>Check the Temperature Manifold Absolute Pressure (TMAP) sensor response and accuracy.</p>
Fuel System Checks	<ul style="list-style-type: none"> • Check for rich or lean symptom that causes the condition. • Drive the vehicle at the speed of the complaint. • Monitoring the oxygen sensors will help identify the problem. • Check for a sticking mixer air valve. • Verify proper operation of the EPR. • Perform a cylinder compression test. Refer to <i>Engine Mechanical</i> in the Service Manual. • Check the EPR fuel pressure. Refer to the <i>LPG Fuel System Diagnosis</i>. • Check mixer assembly for proper installation and connection.
Ignition System Checks	<ul style="list-style-type: none"> • Check for the proper ignition output voltage using the spark tester J26792 or the equivalent. • Verify that the spark plugs are the correct type and properly gapped. <p>Remove the plugs and inspect them for the following conditions:</p> <ul style="list-style-type: none"> • Wet plugs. • Cracks. • Wear. • Improper gap. • Burned electrodes. • Blistered insulators. • Heavy deposits. <p>Check the spark plug wires by connecting an ohmmeter to the ends of each wire in question. If the meter reads over 30,000 ohms, replace the wires.</p>
Additional Checks	<p>Important: The LPG Fuel system is more sensitive to intake manifold leakage than the gasoline fuel supply system.</p> <ul style="list-style-type: none"> • Check for vacuum leaks. Vacuum leaks can cause a higher than normal idle and low throttle angle control command. • Check the ECM grounds for being clean, tight, and in their proper locations. Check the battery cables and ground straps. They should be clean and secure. Erratic voltage may cause all sensor readings to be skewed resulting in poor idle quality.

ROUGH, UNSTABLE, OR INCORRECT IDLE, STALLING

Checks	Action
Engine Mechanical Check	Check the engine for: <ul style="list-style-type: none">• Broken motor mounts.• Improper valve timing.• Low compression.• Improper valve clearance.• Worn rocker arms.• Broken or weak valve springs.• Worn camshaft lobes.

Electrical Section

NOTE: YOU CAN OBTAIN A FULL SIZE ELECTRONIC WIRE DIAGRAM BY CONTACTING THE OEM.

GCP HEADER CONNECTOR

GCP CM0990			
CRK POS	1	PE/VE 18	
CRK NEG	2	VE/PE 18	
5V_rtn1	3	BK/LG 18	
5V_EXT	4	LG/RD 18	
MIL	5	GN/YV 18	
RELAY_LS	6	VE/LB 18	
TACH	7	GY 18	
Vrelay	8	PK/GN 18	
DBW-/STEP-	9	TN/DE 18	
DBW+/STEP+	10	PK/VE 18	
	11		
LOCKOFF	12	VE/BK 18	
START_LS	13	GY/DE 18	
Vbat	14	RD/TN 18	
SPK_SMART1b	15		
SPK_SMART2b	16		
5V_rtn	17		
5V_rtn	18		
Vswitch	19	PK/TN 18	
	20		
FPP2-IVS	21		
FPP1	22	BE/DE 18	
MAP	23	LG 18	
IAT	24	YW/GY 18	
DILP	25	LB 18	
ECT	26	TN/VE 18	
Vrelay	27	PK/GN 18	
Ground	28	BK 18	
SPK_GND	29	BK 18	
	30		
SPK_SMART2a	31		
SPK_SMART1a	32		
CAM 1	33		
AUX_ANA_PUD4	34	TN/BE 18	
AUX_ANA_PUD3	35	BE/RD 18	
AUX_ANA_PUD2	36	BE/YV 18	
AUX_ANA_PUD1	37	TN/BN 18	
FUEL SELECT AUX_DIG2	38	GY/BE 18	
GCP AUX_DIG1	39		
	40		
EGO_1	41	GN/DE 18	
Ground	42	BK 18	
SPK_DUMB1a	43	YV 18	
SPK_DUMB2a	44	YV/RD 18	
TPS1/STEP2+	45	PE/LB 18	
TPS2/STEP2-	46	LB/BE 18	
CAN-	47	BE/VE 18	
CAN+	48	BE/PK 18	
EGDH_1	49	BK/VE 18	
	50		
INJ4_LS	51		
AUX_PWM4	52	TN/BK 18	
INJ3_LS	53		
AUX_PWM3	54	YV/BE 18	
INJ2_LS	55	BN/GN 18	
INJ1_LS	56	BN/LB 18	

Diagnostic Scan Tool (DST)

CONTENTS

- Installation of the DST package to a personal computer (PC).
- Software login and password functionality.
- DST service pages.
- Updating the ECM calibration using a MOT file.
- DTC pages.

Examples and snapshots used in this manual are based off of the initial DST tool release as of July, 2007. This tool is frequently updated and the illustrations may vary depending on the changes included in any updated DST display Interface. For example, the Electronic Pressure Regulator (EPR) may be referred to as the “megajector.” Terms, names and descriptions of parts and servicing procedures will be updated based on trade, brand, or common description to more accurately describe the part or service procedure.

DST INSTALLATION INSTRUCTIONS

Before installing the DST software, please be sure your computer meets the minimum system requirements.

Supported operating systems are:

- Windows Vista
- Windows XP
- Windows 2000
- Windows 7 (Requires Most Current ECOM Driver)

Minimum processor speed:

- Pentium II 450 MHz
- Pentium III 1.0 GHz for Windows Vista

Minimum RAM requirement:

- Windows Vista 512 MB
- Windows XP 256 MB
- Windows 2000 128 MB

* At least one available RS232 serial or USB port.

* ECOM cable supports USB port only.

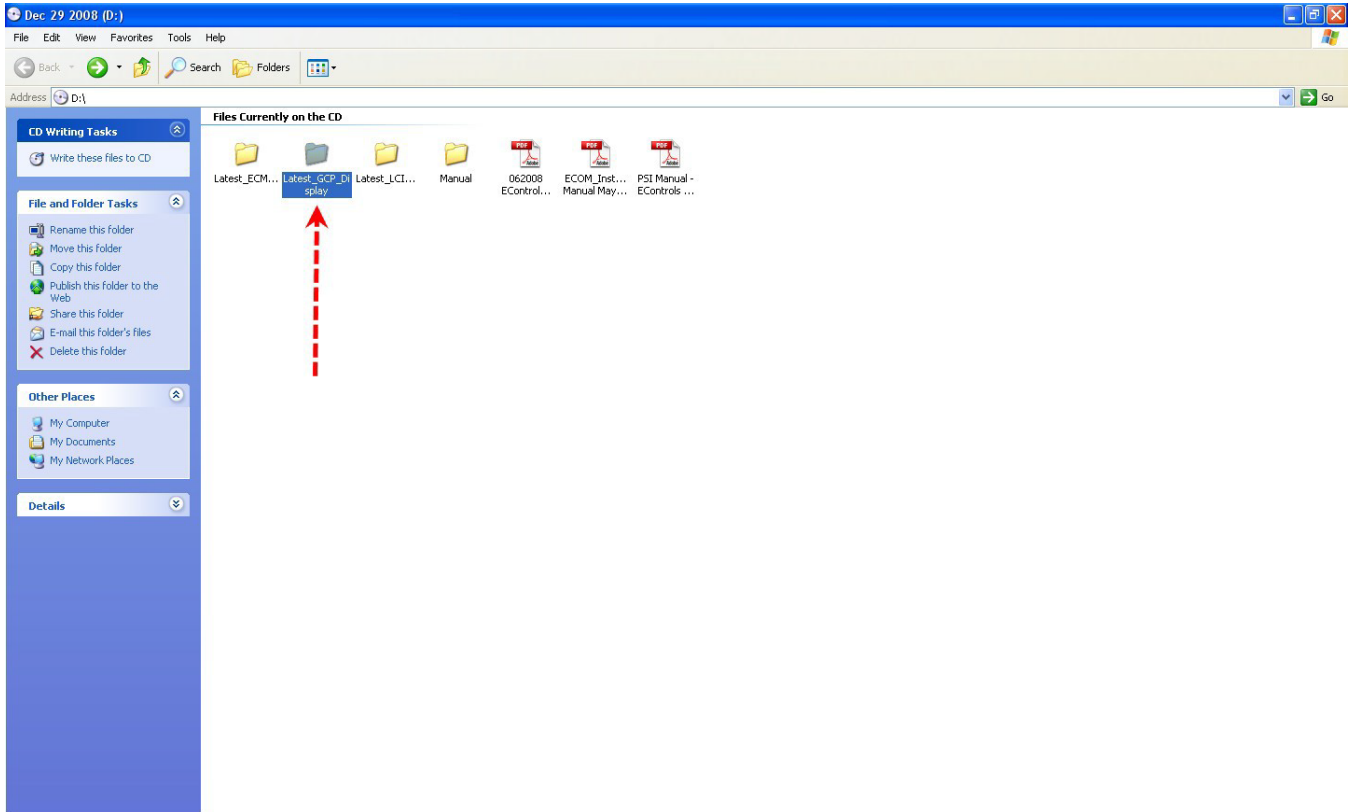

- Insert the CD into your computer and select **LATEST_GCP_DISPLAY**

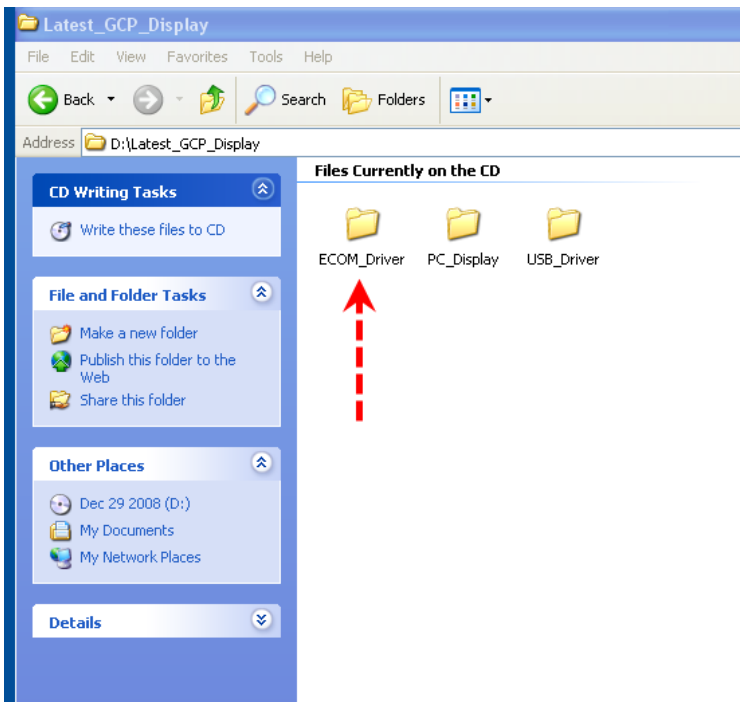

- Open the **ECOM_Driver** Folder

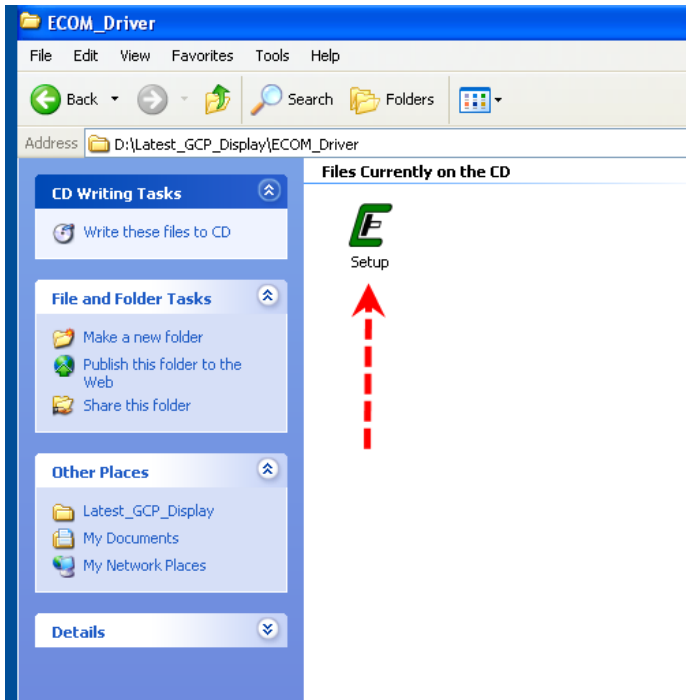

- Double Click the setup.exe file - - - > This will launch the installation wizard
- Select "NEXT" until you finish the installation as shown below

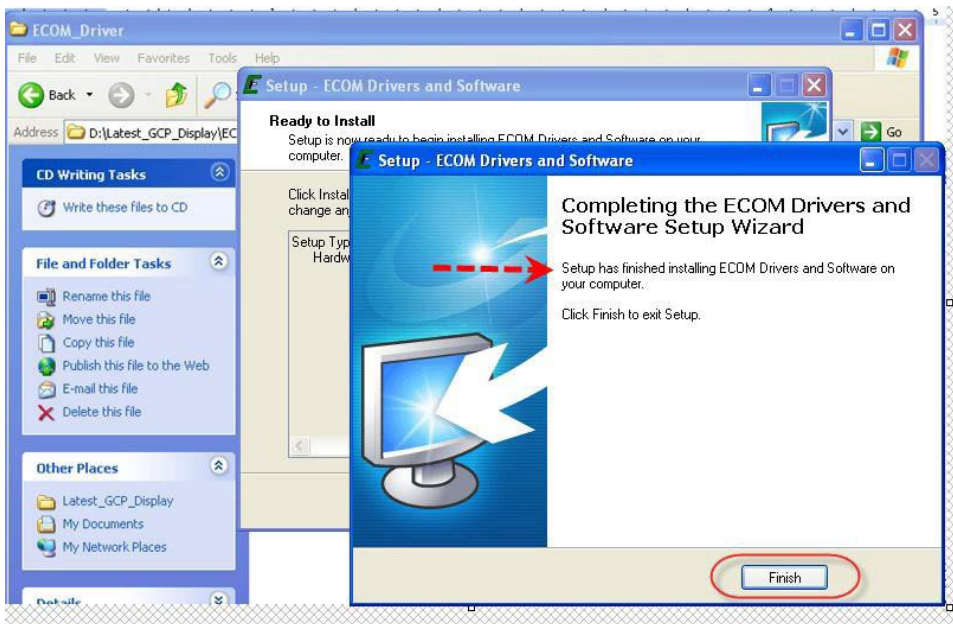

- Return to the **LATEST_GCP_DISPLAY** folder

- Select the PC Display folder

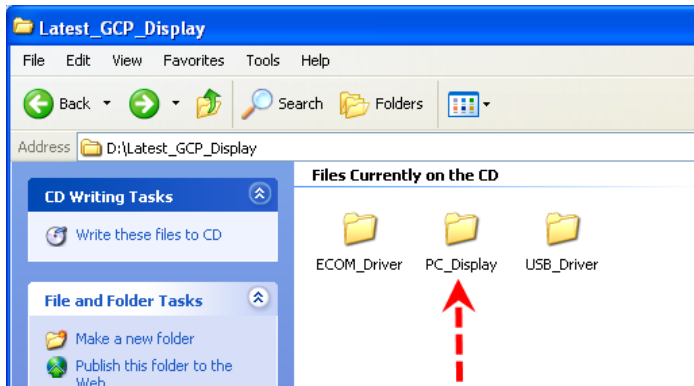

- Select the GCP Display icon

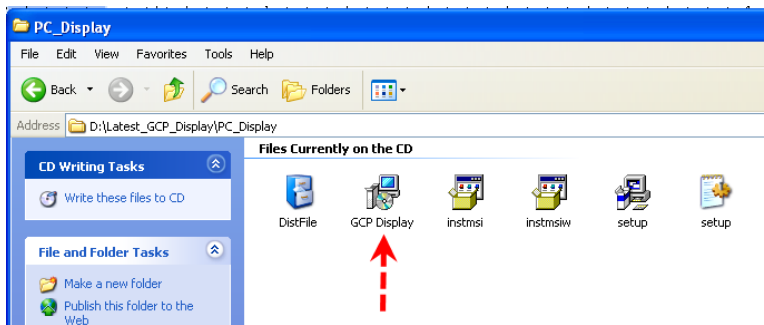

- Select the GCP Display icon - - - > This will launch the installation wizard

- Select NEXT until it says you are finish
- Restart your PC
- Go to the START button on the lower left corner and find the GCP Display Program

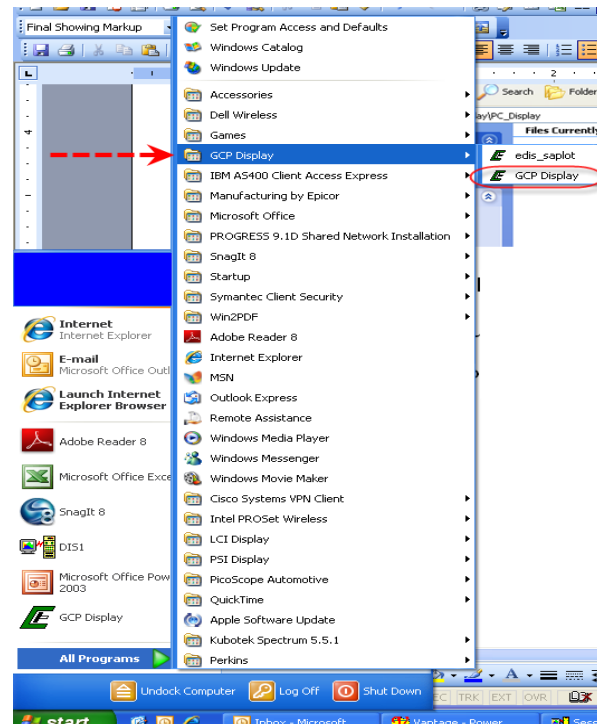

PASSWORD LOGIN

Figure 1 shows the password dialog box, which is displayed when a software session begins. Login can be accomplished in two ways.

1. Enter an “All S/N Password” which is a password applicable to all ECMs of a given original equipment manufacturer (OEM).
2. Enter a “Single S/N Password” and corresponding ECM serial number for a single ECM. A Single Serial Number password is unique to a specific ECM serial number and permits authorized service personnel to make changes or view information for a specific ECM.
3. In most instances the top “all” serial number boxes should be used for password entry. In this case, do not check the single serial number box. Each password is a 16-character alphanumeric string specific to each Spectrum customer and determines which pages and variables are visible through the software. Passwords are assigned by the OEM support group and may change periodically. Check the “save password” box to automatically retain the password for future use.

Note: The password is printed on the CD disk. If it does not have a password or you have questions, please contact the OEM.

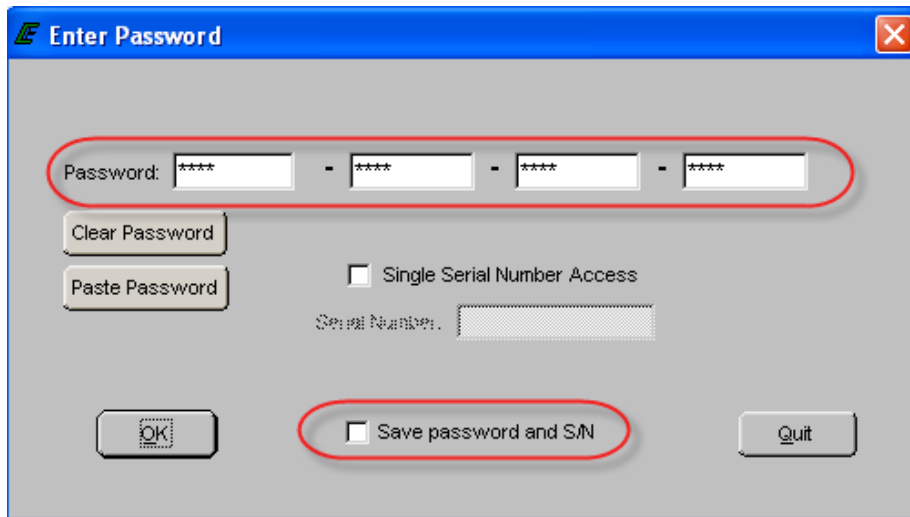

Figure 1: Populated Password Dialog Box

PASSWORD DIALOG BOX FUNCTIONS

- **Clear Password Button** Erases the current password from the password field.
- **Paste Password Button** Allows the user to copy a 16-character string from any word processor and paste the string in the password field.
- **Single Serial Number Access Checkbox** Tells the software that the password is applicable for single serial number access.
- **Serial Number Field** Only applicable when Single Serial Number Access Checkbox is checked. The entry field must be populated for the 6-digit serial number for which the Single Serial Number Access password applies (NOTE: Leading zeros included in the serial number are not required).
- **Save Password and S/N Checkbox** Retains the password, and serial number (if applicable) for the next software session.

Should an invalid password be entered, the error prompt shown in figure (2) will be displayed and the software will not load. This prompt signifies the following:

- The All S/N password is invalid.
- The Single S/N password is incorrect for the Single Serial Number entered.
- An All S/N password is entered for Single Serial Number use.
- The Single Serial Number password is valid; however, the Single Serial Number Access Checkbox is not checked.



Figure 2: Password Error Prompt

If the Single S/N password entered is correct for the software but does not match the entered S/N of the targeted ECM, the prompt in Figure 3 will be displayed.

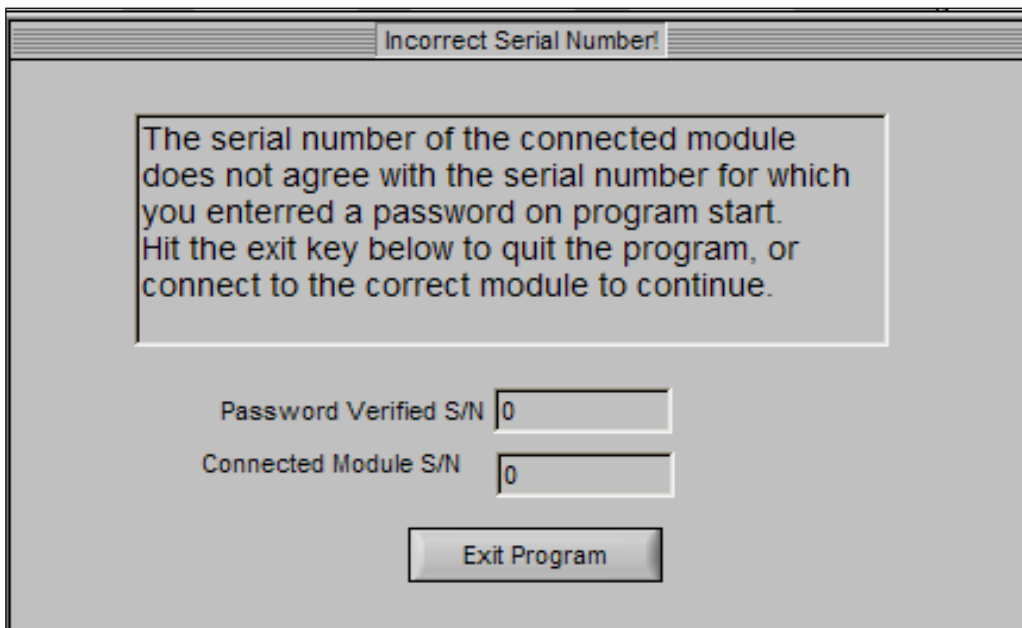

Figure 3: Incorrect Serial Number Message

Figure 4 shows the communication status if a valid software password is entered when attempting to connect to an ECM with a different key. In this instance the software will load but will not connect to the target (ECM).

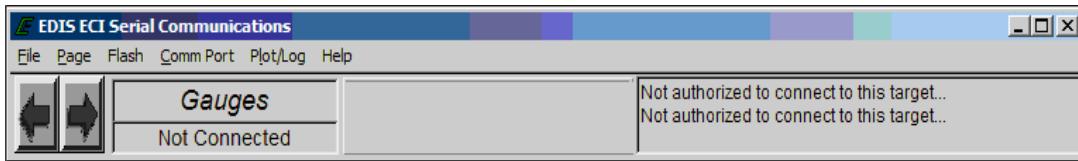
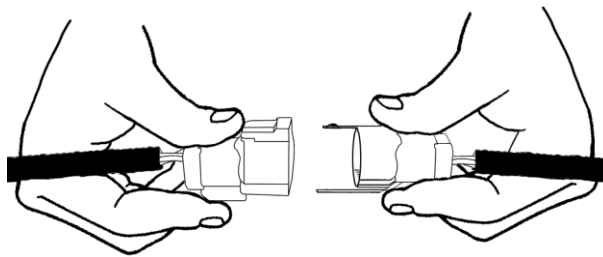

Figure 4: Not Authorized to Connect Message

In the event you receive this error message call your OEM support group for more information.

CONNECTING THE PC TO THE ENGINE WIRE HARNESS



Connecting the DST cable

A laptop computer, with the diagnostic cable and software is the required tool for performing proper diagnostic testing of the fuel system. It is also used to monitor sensor and actuator values and to read and clear Diagnostic Trouble codes. The DST software also performs several special tests.

- Connect the system diagnostic cable to the USB port on the back of the computer.
- Connect the diagnostic cable to the DLC (diagnostic link connector) labeled in the electrical schematic. The DLC is located on the engine harness. The new 8 pin DLC requires the use of the 4 to 8 pin adapter.
- Turn the computer ON.
- Start Windows.
- From the start menu select Programs → PSI GCP Display → PSI GCP Display
- Place the ignition key in the ON position.

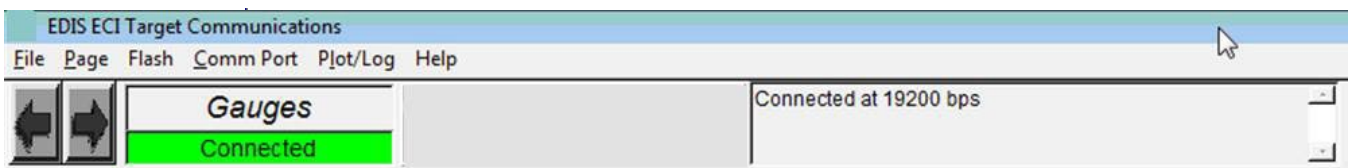

Within several seconds the system Gauge screen should now appear and a green banner in the upper left hand will read “Connected.”

- Connecting to the PC using the ECOM cable

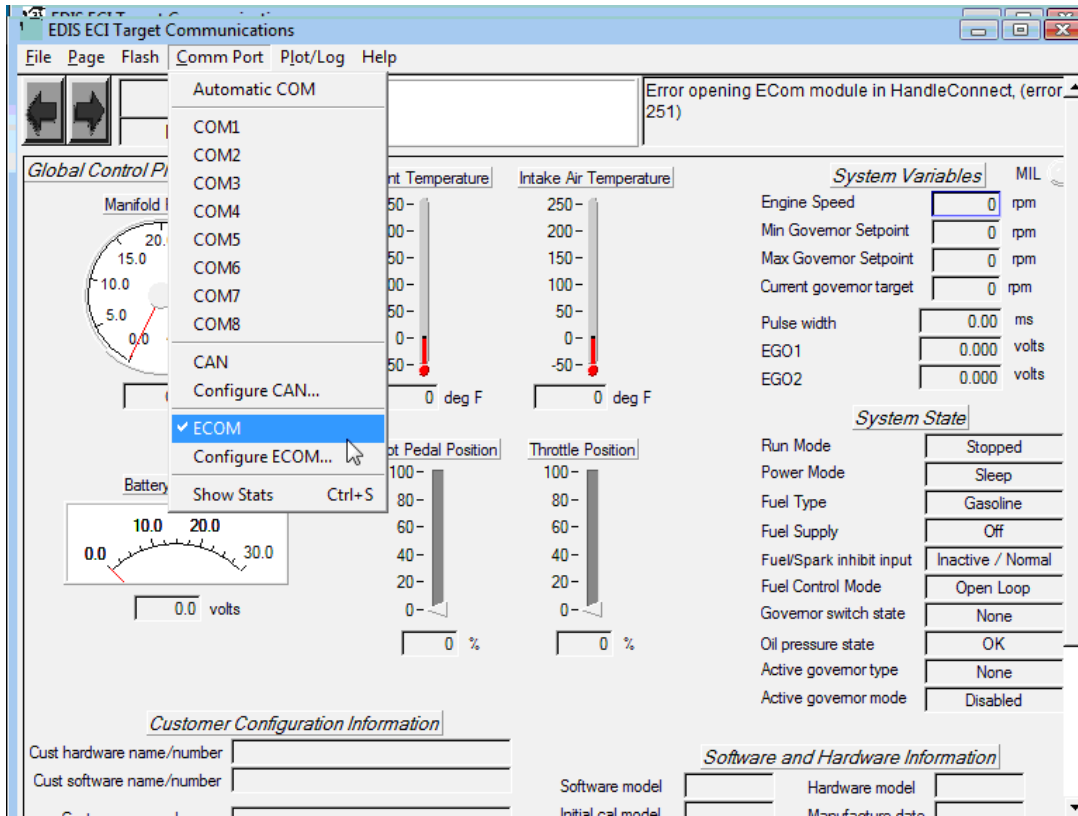

- To connect using the ECOM cable you must select ECOM from the COM Port drop down menu.

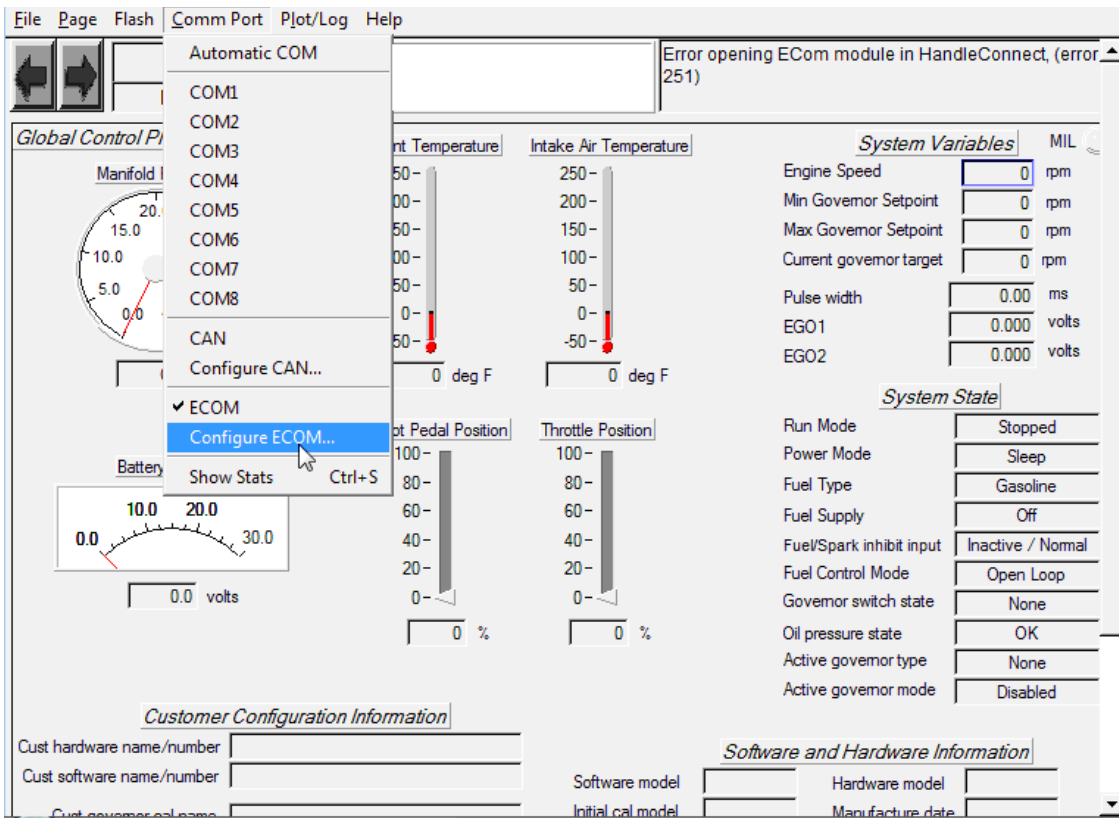

- You will now need to configure the ECOM communication protocol.

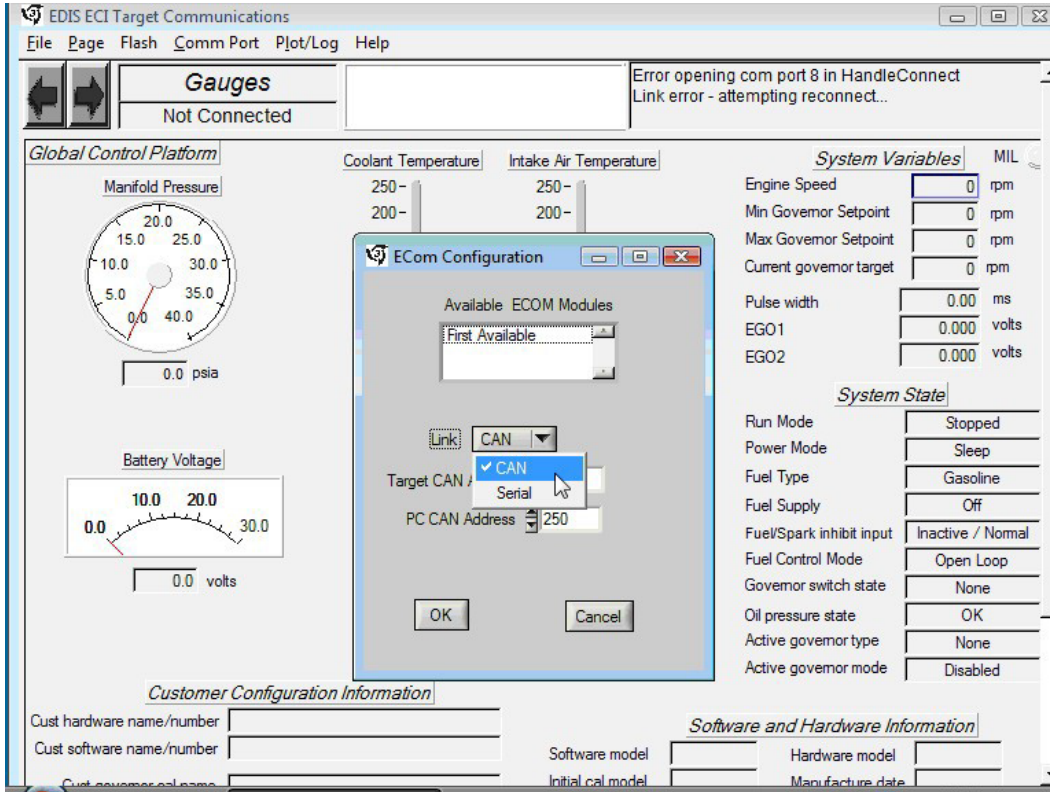

- Select the CAN for systems with CAN enabled or serial for all others. Then select OK. You are now ready to connect using the ECOM USB DLC cable.

DST SERVICE PAGES

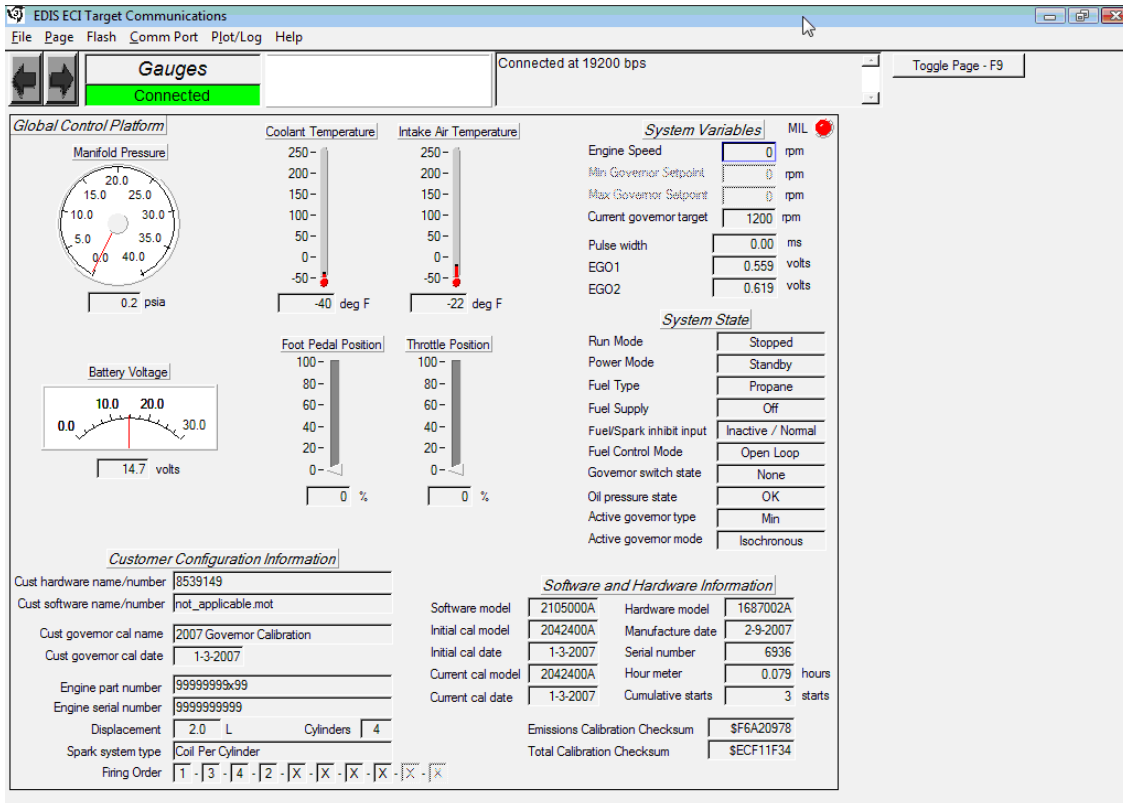

Gauge Page

Provides system data in large easy to read displays. Displays ECM configuration information for the ECM software, hardware, serial numbers and calibration dates.

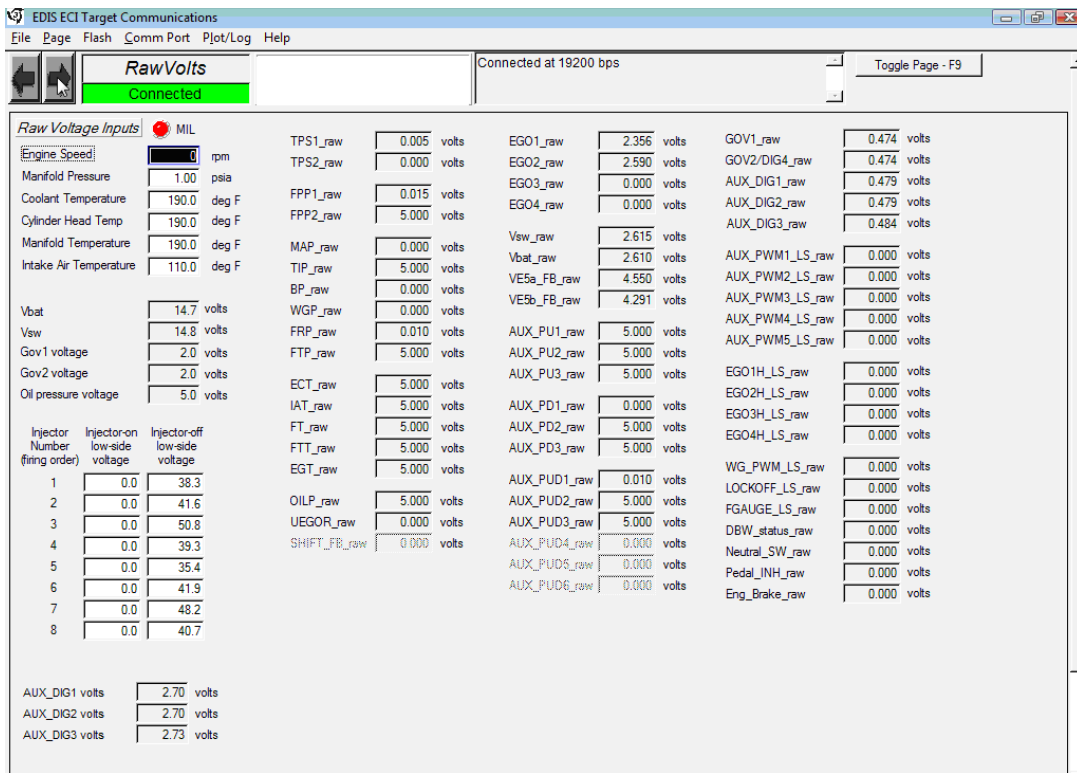

Raw Volts Page

The raw volts page displays the sensor inputs and outputs in a raw voltage format. This page is most commonly used to check values in the diagnostic trouble shooting charts.

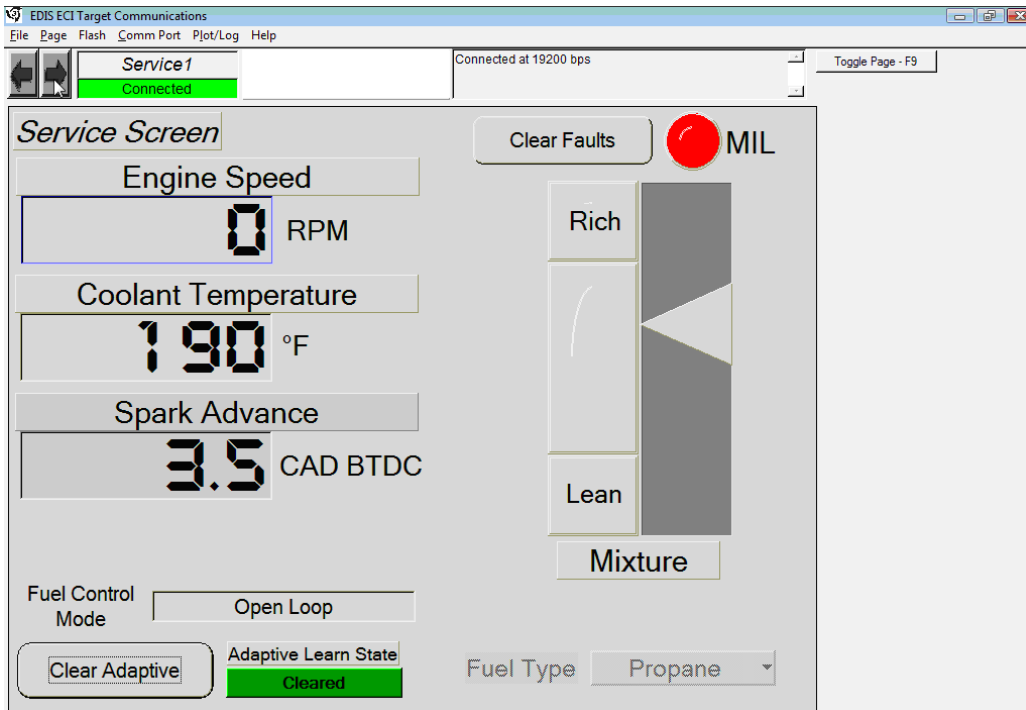

Service 1

The Service 1 screen is used to clear the adaptive learn, shows the MIL status and provides a display for rpm, coolant temperature and spark advance. It also provides a large display to monitor the closed loop mixture control.

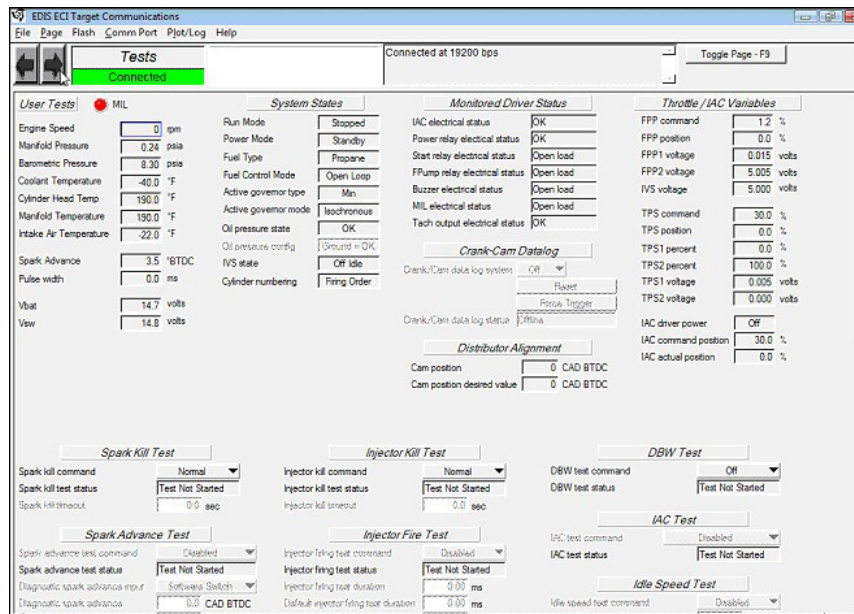

Tests Page

Provides diagnostic information voltages and sensor outputs and includes diagnostic engine tools such as spark and injector kill controls. Please note that not all features are available for all applications. The disabled item menus are grayed out or rendered inoperative.

SPARK KILL

The spark kill mode allows the technician to disable the ignition on individual cylinders. If the Spark Kill diagnostic mode is selected with the engine running below 1000 rpm, the minimum throttle command will lock into the position it was in when the test mode was entered. If the Spark System Test mode is selected with the engine running above 1000 rpm, the throttle will continue to operate normally. Disabling Ignition Outputs to disable the ignition system for an individual cylinder, use the mouse to highlight the “Spark Kill” button and select the desired coil. The spark output can be re-enabled by using the mouse to highlight the “Spark Kill” button and selecting “Normal.” If the engine is running below 1000 rpm, the spark output will stay disabled for 15 seconds and then re-set. If the engine is running above 1000 rpm, the spark output will stay disabled for 5 seconds and then re-set. This test mode has a timeout of 10 minutes. Record the rpm drop related to each spark output disabled. The spark outputs are arranged in the order which the engine fires, not by cylinder number.

INJECTOR KILL

The Injector Kill mode is used to disable individual fuel injectors. If the Injector Kill mode is selected with the engine running below 1000 rpm, the minimum throttle command will lock into the position it was in when the test mode was entered. If the Injector Kill mode is selected with the engine running above 1000 rpm, the throttle will continue to operate normally. To disable an injector, use the mouse to select the desired injector. The word “Normal” will change to the Injector you have selected. The injector driver can be re-enabled by selecting again. If the engine is running below 1000 rpm, the injector driver will stay disabled for 15 seconds and then re-

set. If the engine is running above 1000 rpm, the injector driver will stay disabled for 5 seconds and then re-set. Record the change in rpm while each driver is disabled.

DBW TEST MODE

The DBW (Drive by Wire) test mode allows the technician to control the throttle directly with the foot pedal or throttle input and is used during the diagnostic routines specified for FPP and TPS for Spectrum systems that use DBW control. FPP position displays the current position of the foot pedal as a percentage. FPP volts display the voltage which the ECM is reading from the FPP sensor. TPS Command displays the commanded throttle position expressed as a percentage, which is being sent to the throttle. TPS Position is the actual percent of throttle opening being sent to the ECM from the throttle. TPS volts display the actual TPS signal voltage the ECM is receiving from the throttle. To select this test mode, the engine must be off and the key must be in the ON position.

EXTERNAL POWER TEST

The external power test manually activates relays (relay power, fuel pump, and drive-by wire power) controlled by the ECM while the engine is in the “Stopped” or “Running” states. Reverts to normal operation if “Automatic” state is selected or ignition voltage is cycled from high to low.

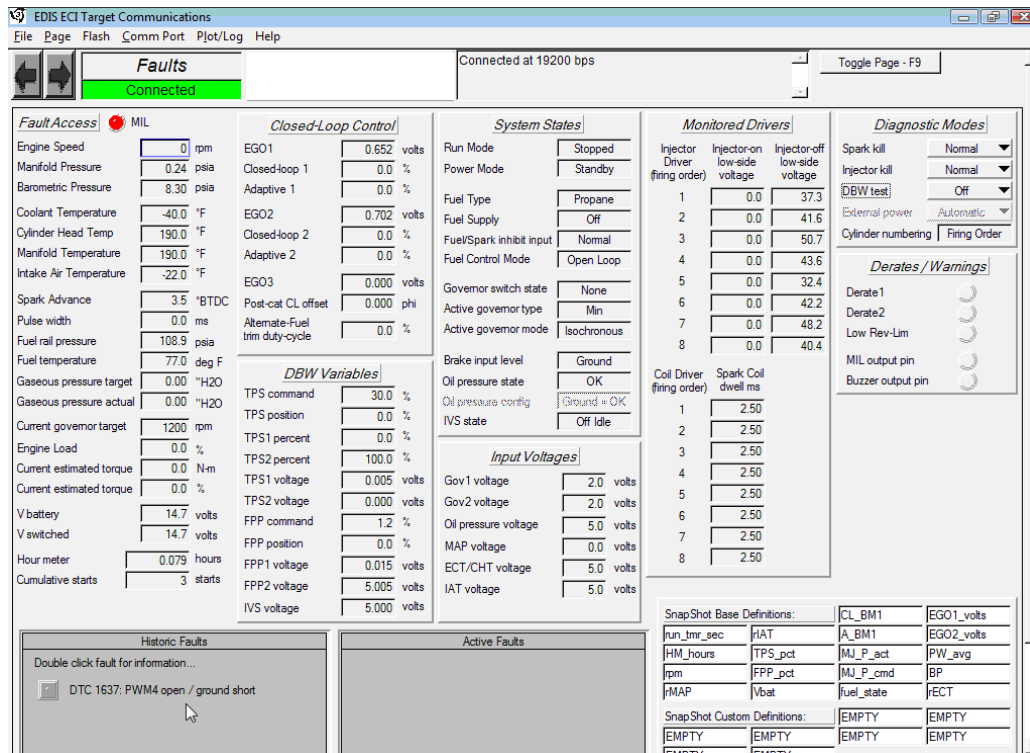

Faults Page

Stores DTC codes that may have occurred in the past (Historic Faults) or current set codes (Active Faults). Includes useful system voltages and sensor readings used while working with the fuel and emission trouble shooting charts. Shows power derate mode status. To erase a historic DTC code, double click on the code with the left mouse button. Then choose to “Clear All Faults.”

PLOT/LOG MENU FUNCTIONS

The Plot/Log menu allows the user to graphically plot or numerically log variables that have been tagged for plotting/logging. To plot or log variables, a tag must be assigned to each variable of interest. A variable is tagged for plotting/logging through a single right-mouse click in the variable's vicinity. Once a variable has been tagged for plotting/logging, it is highlighted in green.

Figure 5 shows an example of variables that have been tagged. A maximum of twenty (20) variables may be tagged for logging and a maximum of ten (10) variables may be tagged for plotting. The maximum achievable sample frequency/minimum period is dependent on the number of variables tagged.

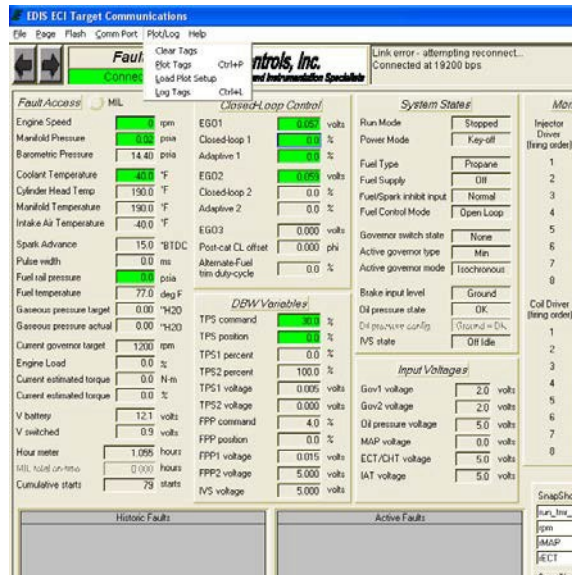

Figure 5: Tagged Variables for Plot/Log

Once the variables have been tagged as highlighted by the green color fill, select the "Plot/Log" function in the top menu bar as shown below in figure 6.

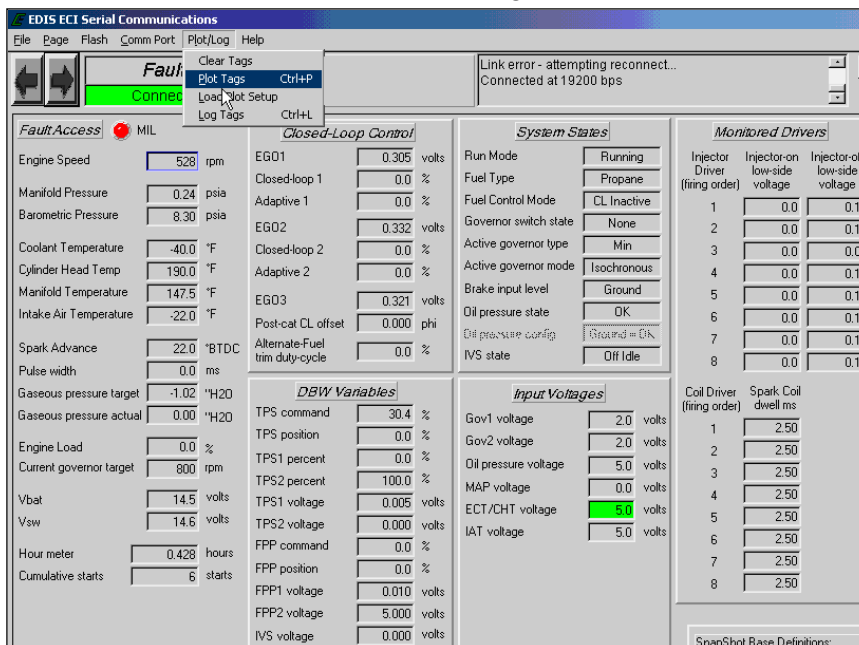

Figure 6

- Select “Plot Tags” to open the snapshot window Other

functions available from the Plot/Log menu include:

- **Clear Tags:** Releases all plot/log variables.
- **Plot Tags (Ctrl + P, or P):** Graphically plot all tagged variables.
- **Load Plot Setup:** Loads and tags variables for plotting/logging that have been stored in a plot file (.plt).
- **Log Tags (Ctrl + L):** Numerically log all variables that have been tagged for plotting/logging.

Once the Plot Tags menu item has been selected, tagged variables are graphically plotted in a strip chart interface. An example of a plot is shown in Figure 7. Capabilities of the plotter are outlined in Table 1.

Start/Stop Button	Start or stop plotting of selected variables
Save Button	Save plotted data displayed in the plot to a comma-separated value file (CSV) on the PC hard drive. Format must not be altered if the <i>Load</i> function is to be used.
Snapshot Button	Convert the plot into a snapshot that may be panned, zoomed, scrolled, and saved
Close Button	Close the DST Plot interface
Load Setup Button	Load tags from a previously saved plot (.plt) file to allow for similar plots and logs to be generated
Load Plot Button	Load a previously saved plot from the PC into the DST Plot interface
Variable Selector Menu	Selects the active variable for axis scaling
Single Shot Acquisition Checkbox*	When checked, this does not allow the plot to scroll past the ‘Time Interval’ thereby preserving plotted data for post-processing.
Exclusive Serial Use Checkbox*	When checked, this allows exclusive serial communication for the plot variables. Other variables on the active page are not updated.
Min Y Value Field*	Specify the minimum Y-axis scaling for the active variable
Max Y Value Field*	Specify the maximum Y-axis scaling for the active variable
Sample Interval (ms) Field*	Define the sample period for recording and display <i>Frequency (Hz.) = 1000/Sample Interval (ms)</i>
Time Interval (s) Field*	Defines the total sample acquisition time for the plot.
*Accessible only when plotter is not running.	

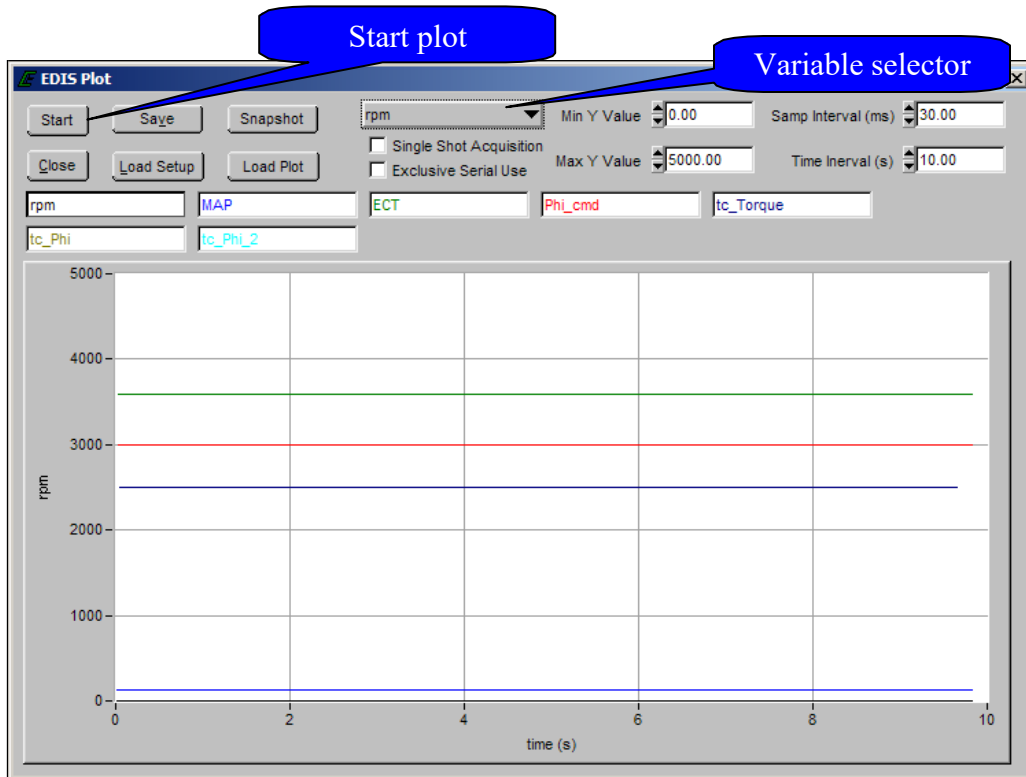

Figure 7: DST Plot

- Click on the “Start” button to start the DST plot function.
- Click on the variable selector button to view selected sensors

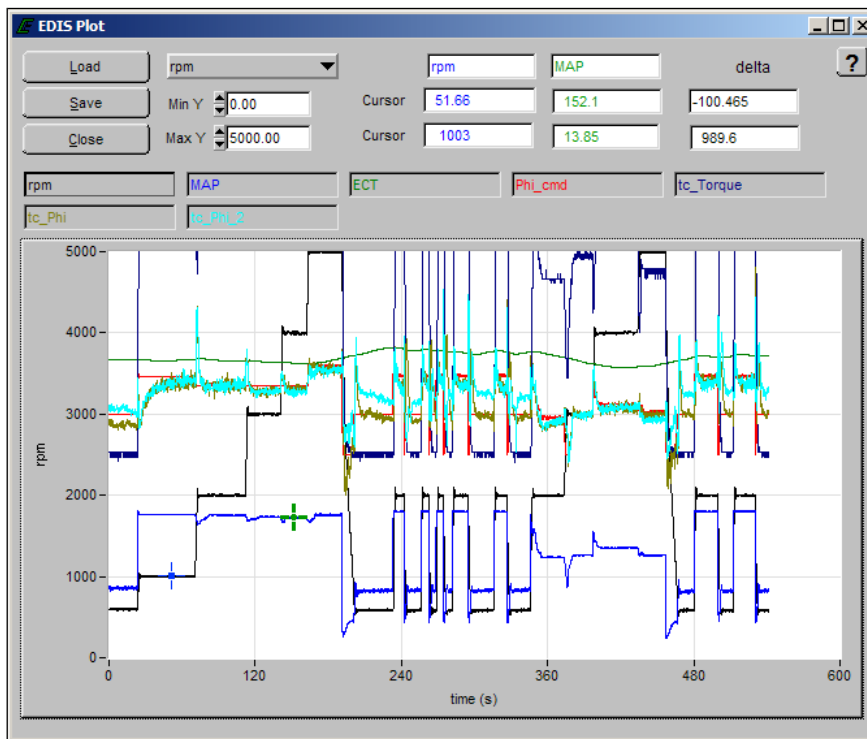
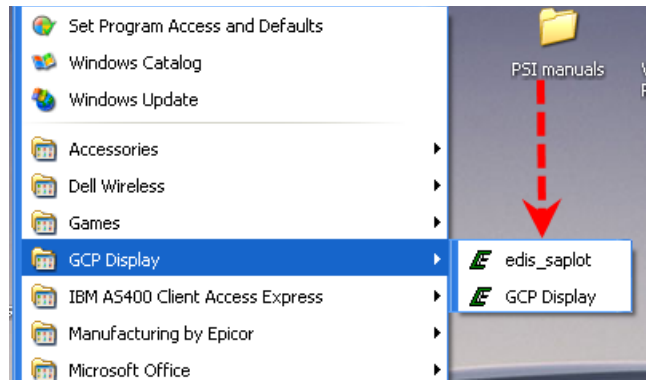

Figure 8: DST Plot Snapshot

- Click on the “Save” button to save the snapshot as a file. To replay the saved file, open the edis_saplot program from the windows start menu.



- Start Menu → Programs → PSI GCP Display → edis_saplot

DST PLOT INTERFACE FUNCTIONS

A graphic tool incorporated in the plotter is the snapshot function. This function allows data collected in a plot to be transferred into a second window for quick graphical post-processing. The snapshot allows the user to zoom in/out, pan left/right, and move cursors along the signal traces to measure the variable values in virtual real-time. An example of a snapshot is shown in Figure 8. Any CSV file in plot format (.plt) may be loaded into the snapshot. Table 2 outlines the available hot key functions of the snapshot screen.

SNAPSHOT HOT KEY FUNCTIONS

Command	Function
<Single, left-click on trace>	Snap closest cursor to data
<Ctrl + Up/Down Arrows>	Move/pan plot along y axis
<Ctrl + Left/Right Arrows>	Move/pan plot along t axis
<Ctrl+Shift + Up/Down Arrows>	Zoom plot in and out in y axis
<Ctrl+Shift + Left/Right Arrows>	Zoom plot in and out in t axis
<Ctrl + Home>	Resize plot to default settings
<Ctrl + Page Up>	Zoom out by 10%
<Ctrl + Page Down>	Zoom in by 10%
<Page Up>	Toggle to previous cursor
<Page Down>	Toggle to next cursor
<Left/Right Arrow>	Follow selected data along trace
<Up/Down Arrow>	Follow selected data along trace
<Shift + Left/Right Arrow>	Move 10 points along trace
<Shift + Up/Down Arrow>	Move 10 points along trace
<Home>	Go to first visible point on current plot
<End>	Advance to last visible point on current plot
<Shift + Up/Down Arrow>	Toggle between traces/variables

Table 1

DST LOGGER

Another data capture function incorporated in the software is the DST logger. This tool serves as a PC data logger for any variable available in the ECM through the interface software. Figure 9 shows the interface display for configuring the DST Log. The interface allows the user to create the filename, set the sample rate for acquisition, set the time interval for sampling, and display the progress of acquisition. A maximum of twenty (20) variables may be tagged for the log. The amount of data stored is only limited by available PC RAM. The resulting text file may then be viewed by any standard Windows text editor/reader program. To create a log file select the “Log Tags” in the drop down menu as shown in figure 6.

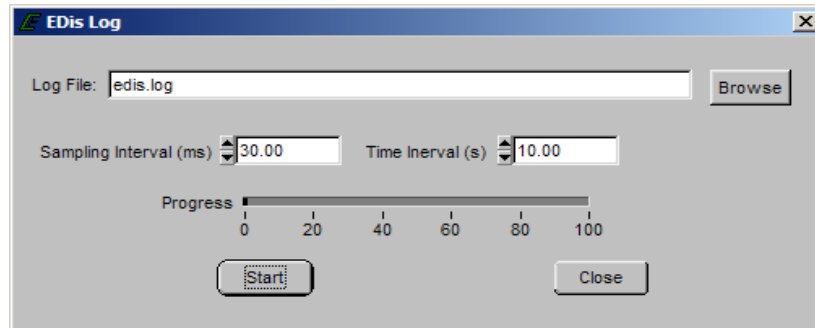

Figure 9: DST Log Interface

MALFUNCTION INDICATOR LAMP (MIL)

The Fuel system has built-in diagnostics for system trouble shooting. The system has a dash mounted malfunction indicator lamp (MIL) that provides indications of engine or fuel system related problem. Most engine control system related problems that affect emissions or drivability of the vehicle will set a (DTC) diagnostic trouble code and illuminate the MIL.

The MIL serves as notification to the operator of a problem related to the emission control system so the driver can arrange for service as soon as possible. It will also display DTCs that have been stored due to a system malfunction.

The MIL should illuminate when the key is in the ON position and the engine is not running. This feature verifies that the lamp is in proper working order. If the MIL does not illuminate with the vehicle key ON/engine OFF, repair it as soon as possible. Once the engine is in start or run mode, the MIL should turn off. If the lamp remains on while the engine is in the start or run mode a diagnostic trouble code may be set.

The MIL will be turned OFF after three (3) consecutive run cycles or by clearing the active code with the Diagnostic Scan Tool (DST).

DIAGNOSTIC TROUBLE CODES (DTC)

Diagnostic Trouble Codes are set when the Spectrum ECM (Electronic Control Module) runs a diagnostic self-test and the test fails. When a DTC is set, the ECM will illuminate the MIL on the instrument panel and also save the DTC in memory. The ECM will continue to run the self-test. If the system continues to fail the test, the lamp will stay illuminated and the DTC is stored as an active DTC. If the self-test runs and passes, the DTC will be stored as historic DTC. All DTCs are stored as historic faults until they are cleared. Most DTCs will automatically clear from memory if

the DTC does not reset within 50 to 100 consecutive engine run cycles.

While a Diagnostic Trouble Code is current for a sensor, the ECM may assign a default “limp home” value and use that value in its control algorithms. All of the system diagnostic self-tests run continuously during normal vehicle operation.

The Diagnostic Trouble Codes can be read by using either the MIL lamp or a laptop computer. Diagnostic Trouble Codes can be cleared from memory with a laptop computer, or by turning the ignition key to the OFF position and removing the ECM power fuse or battery cable for at least 15 seconds.

If more than one DTC is detected, start the diagnostic repair with the lowest DTC number set. Diagnose each problem to correction unless directed to do otherwise by the diagnostic chart. The DTCs are numbered in order of importance. Both DTC 112 and DTC122 pertain to the oxygen sensor, so it is possible that a repair that corrects DTC 112 may also correct the problem causing the DTC 122.

Diagnostic test charts contained in this manual refer to the DST to be connected and in the “System Data Mode.” This simply means that the DST is connected and communicating with the PC. In some instances, the chart will call out a special test mode. An example of this would be instructions for the DST to be connected and in the DBW (drive by wire) mode. Always be sure to follow the special instructions to avoid a false diagnosis of fuel system components.

DLC COMMUNICATION ERROR

The ECM 5 volt reference circuit powers the Spectrum diagnostic link cable. In the event that the 5 volt reference signal is open or shorted to ground, you will not be able to connect to the system. If you are unable to connect, follow the quick checks listed below:

Be sure you are using the correct password and latest software for the system you are connecting to.

Check the ECM system power and ground circuits. Refer to DTC 562 for the power schematic. Also check for +12 volts switched power at ECM pin 45 with the ignition key ON.

Check for power at the DLC connector for + 5 volts between pin 1 (BLK /LT GRN) and pin 2 (LT GRN RED) with the ignition key in the ON position.

You may still be able to retrieve a code using the blink code function if none of the above recommendations prove useful. In the event of a 5 volt reference signal malfunction, DTC 642 or DTC 643 should set. If you find one of these codes using the blink code function, follow the DTC diagnostic chart recommendations for that specific DTC.

BLINK CODE FUNCTION

The DST is considered a required tool to access the DTC codes. DTC codes cannot be retrieved without a laptop computer. This engine is **not** capable of displaying DTC blink codes.

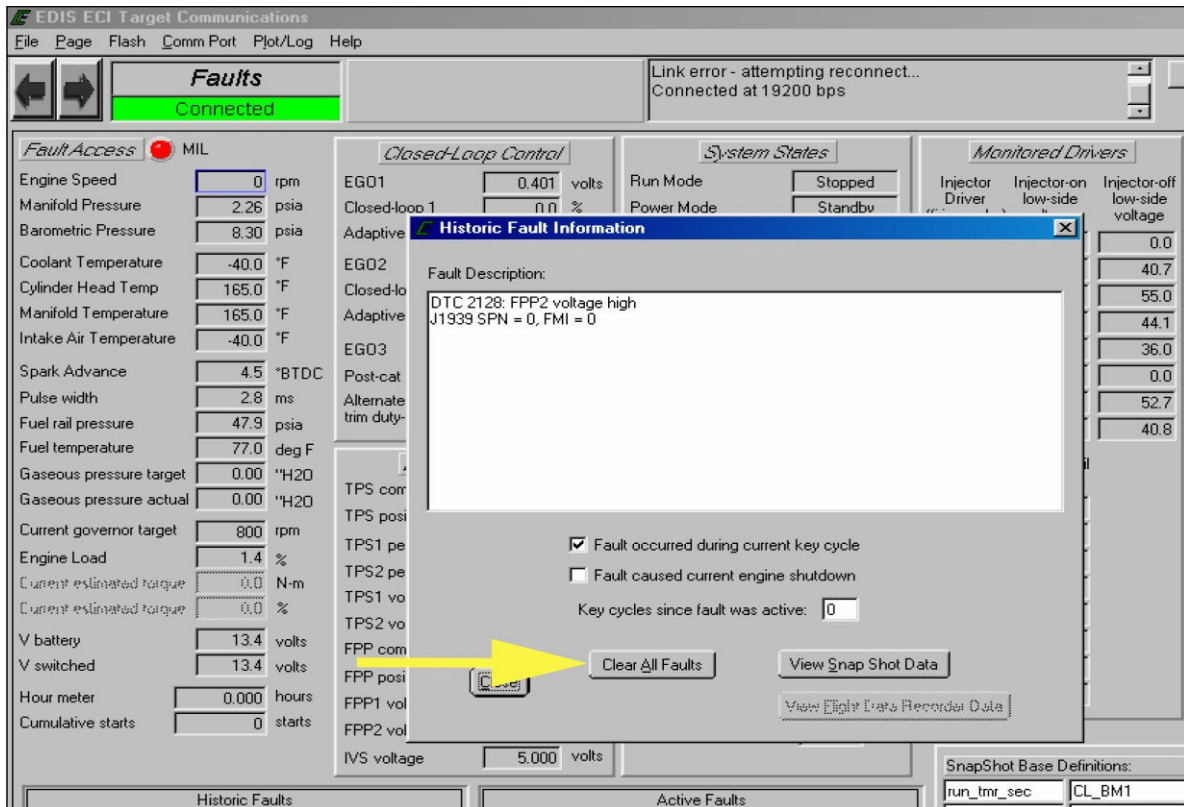

Diagram 1

When using the DST program to clear a DTC, always select the “Clear All Faults” function to immediately turn the MIL OFF after a successful repair (as shown in diagram 1 above).

INTERMITTENT PROBLEMS

Intermittent fuel system problems can prove to be the most challenging to repair. It is most important to remember when looking to find the cause of these problems, to operate the system in the condition when and where the problem occurs. An example of this would be, if the DST showed a lean fuel mixture at full load, one of the first things to look at would be the fuel pressure. The fuel pressure would need to be monitored while the machine is operating at full load, not at idle because the leaning effect does not occur at idle. Electrical problems should be treated the same way. One excellent tool for finding intermittent electrical problems is the DST plot/log function. Set up the plot for the code that sets. An example of this would be if an intermittent IAT code set, tag the IAT voltage and watch the plot. While watching the plot, agitate the electrical wire connection at the sensor and ECM connector. The resolution of the plot screen is such that you will be able to see any unstable voltages that you would otherwise not see with a standard DVOM.

Caution should be used when pressure washing the under hood of any electrical system. Avoid direct pressure spray on the system electrical connectors. They are splash proof, but if water is sprayed directly at the connector moisture can become trapped behind the connector seal and cause serious system problems.

Extra care must be taken when probing electrical pins and terminals. Do not bend or spread these terminals as this can also be a source of intermittent problems cause by improper handling of these connectors.

Engine Wire Harness Repair

ON-VEHICLE SERVICE WIRE HARNESS REPAIR

The ECM harness electrically connects the ECM to various components in both the engine and passenger compartments.

Wire harnesses should be replaced with proper part number harnesses. When wires are spliced into a harness, use wire with high temperature insulation only.

Low current and voltage levels are used in the system, so it is important that the best possible bond at all wire splices be made by soldering the splices.

CONNECTORS AND TERMINALS

Use care when probing a connector or replacing terminals in them to prevent shorting opposite terminals and damage certain components. Always use jumper wires between connectors, for circuit checking. Do not probe through the Weather-Pack seals with oversized wire probes. Use tachometer adapter J 35812 (or equivalent) which provides an easy hook up of the tach lead. The connector test adapter kit J 35616 (or equivalent), contains an assortment of flexible connectors used to probe terminals during diagnosis. Fuse remover and test tool BT 8616, or equivalent, is used for removing a fuse and to adapt fuse holder, with a meter, for diagnosis. Do not solder oxygen sensor wire terminals as these wire ends are used for the sensors oxygen reference.

Open circuits are often difficult to locate by sight due to dirt, oxidation, or terminal misalignment. Merely wiggling a connector on a sensor, or in the wiring harness, may correct the open circuit condition. This should always be considered, when an open circuit, or failed sensor is indicated. Intermittent problems may also be caused by oxidized or loose connections.

Before making a connector repair, be certain of the type of connector. Weather-Pack and Compact Three connectors look similar, but are serviced differently.

REPAIRING TWISTED/SHIELDED CABLE

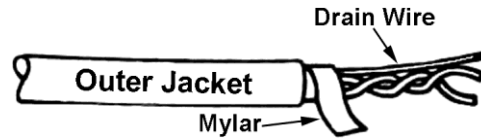

1. Remove outer jacket
2. Unwrap aluminum/Mylar tape. Do not remove Mylar.



3. Untwist conductors, strip insulation as necessary.

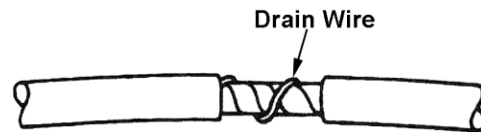

4. Splice wire using splice clips and rosin core solder. Wrap each splice to insulate.
5. Wrap with Mylar and drain wire (uninsulated) wire.



6. Tape over entire juncture and secure.

REPAIRING TWISTED LEADS



1. Locate Damaged Wire.
2. Remove insulation as required.

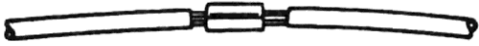

3. Splice two wires together using splice clips and rosin core solder.

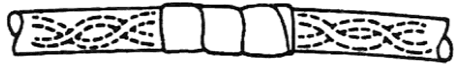

4. Cover splice with tape to insulated from other wires.
5. Retwist as before and tape with electrical tape and hold in place.

MICRO-PACK

Refer to Figure 2 and repair procedure for replacement of a Micro-Pack terminal.

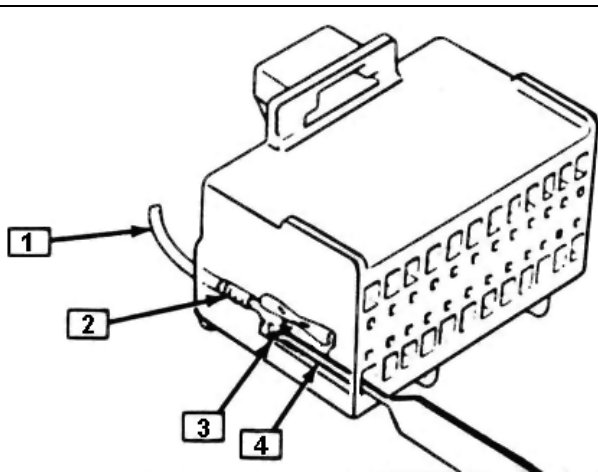

Micropack Connector

1. Cable
2. Terminal
3. Locking Tang
4. Tool J33095/BT8234-A

METRI-PACK

Some connectors use terminals called Metri-Pack Series 150. They are also called "Pull-To-Seat" terminals because of the method of installation. The wire is inserted through the seal and connector, the terminal is crimped on the wire and then pulled back into the connector to seat it in place.

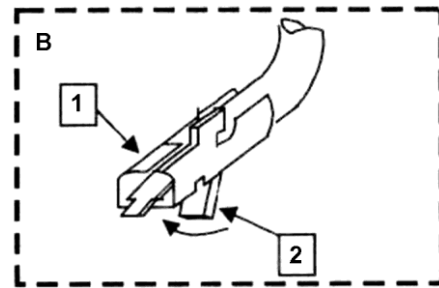
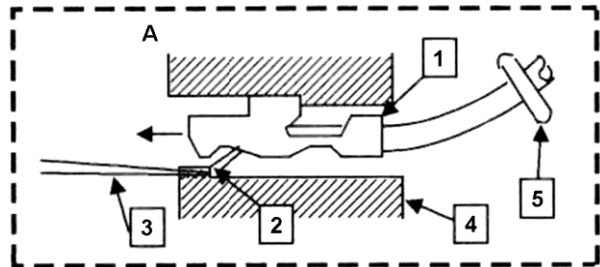

Metri-Pack Series 150 Terminal Removal

1. Slide the seal back on the wire.
2. Insert tool BT-8518, or J 35689, or equivalent, as shown in insert "A" and "B" to release the terminal locking tab (2).
3. Push the wire and terminal out through the connector. If reusing the terminal, reshape the locking tab (2).

WEATHER-PACK

A Weather-Pack connector can be identified by a rubber seal, at the rear of the connector. The connector is used in the engine compartment to protect against moisture and dirt that may oxidize and/or corrode the terminals. Given the low voltage and current levels found in the electronic system, this protection is necessary to ensure a good connection.

WEATHER-PACK TERMINAL REPAIR



1. Open secondary lock hinge on connector.

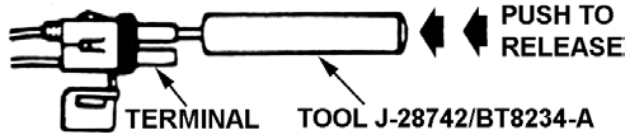

2. Remove terminal using tool.

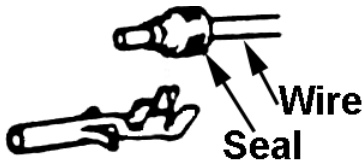

3. Cut wire immediately behind cable seal

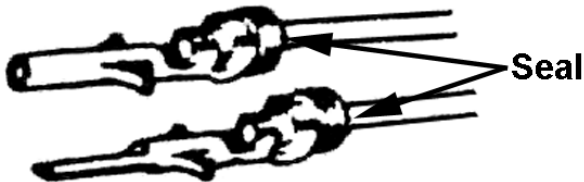

4.

5. Replace terminal.
 - a. Slip new seal onto wire
 - b. Strip 5 mm (.2") of insulation from wire.
 - c. Crimp terminal over wire and seal.

6. Push terminal and connector and engage locking tangs.

7. Close secondary lock hinge.

Use tool J M28742, or BT8234-A or equivalent to remove the pin and sleeve terminals. If the removal is attempted with an ordinary pick, there is a good chance that the terminal will be bent, or deformed. Unlike standard blade type terminals, these terminals cannot be straightened once they are bent.

Verify that the connectors are properly seated and all of the sealing rings in place, when connecting leads. The hinge type flap provides a backup, or secondary locking feature for the connector. They are used to improve the connector reliability by retaining the terminals, if the small terminal lock tabs are not positioned properly.

Weather-Pack connections cannot be replaced with standard connections. Additional instructions are provided with Weather-Pack connector and terminal packages.

Diagnostic Trouble Codes (DTCs)

Malfunction Indicator Lamp (MIL) Operation

How does my MIL work?

The emissions control system utilizes a MIL to warn the operator or technician of a possible issue with the engine or emissions control system. The system will keep the MIL illuminated for the entire key cycle in which the trouble code was set. It will keep the MIL illuminated for three additional engine run cycles under the following two circumstances: (1) The fault caused the engine to shut down or (2) the fault is related to the exhaust gas oxygen (EGO) sensors. This function is called MIL persistence.

How does MIL persistence work?

In the event the DTC **is** related to either an engine shutdown fault OR an oxygen sensor fault the following statement applies: If the vehicle is not serviced by a technician and the condition causing the MIL illumination (DTC) no longer exists, the MIL will remain illuminated for the 3 additional start cycles. The MIL will go out on the 4th start cycle if the condition does not re-occur.

In the event the DTC **is not** related to an engine shut down or an oxygen sensor fault and the condition causing the MIL illumination (DTC) no longer exists, the MIL will go out at the next run cycle.

If the condition is serviced by a technician and the DTC is cleared using a Diagnostic Service Tool (DST), the MIL will go out immediately.

Diagnostic Trouble Codes (DTC) are permanently retained in the historic DTC section until cleared with a DST or the auto clear requirements are met. The auto clear feature will clear out historic faults after 40 run cycles.

What are the requirements for a run cycle?

A run cycle is when the engine speed is above the “run speed” set point for 1.5 seconds or longer. The “run speed” is the transition point when the ECM recognizes the engine is going from the cranking parameters to the engine running parameters. The run speed is typically set at 450 rpm.

DIAGNOSTIC TROUBLE CODE (DTC) CHART – **SORTED BY DTC # (1 of 4)**

Description	DTC Set 2		Description	DTC Set 2	
	SPN-2	FMI-2		SPN-2	FMI-2
DTC 11: Intake cam / distributor position error	520800	7	DTC 268: Injector 3 coil shorted	653	6
DTC 16: Crank and/or cam could not synchronize during start	636	8	DTC 270: Injector 4 open or short to ground	654	5
DTC 24: Exhaust cam position error	520801	7	DTC 271: Injector 4 coil shorted	654	6
DTC 87 Fuel pressure lower than expected	94	1	DTC 273: Injector 5 open or short to ground	655	5
DTC 88 Fuel pressure higher than expected	94	0	DTC 274: Injector 5 coil shorted	655	6
DTC 91: FP low voltage	94	4	DTC 276: Injector 6 open or short to ground	656	5
DTC 92: FP high voltage	94	3	DTC 277: Injector 6 coil shorted	656	6
DTC 107: MAP voltage low	106	4	DTC 279: Injector 7 open or short to ground	657	5
DTC 108: MAP pressure high	106	16	DTC 280: Injector 7 coil shorted	657	6
DTC 111: IAT higher than expected stage 1	105	15	DTC 282: Injector 8 open or short to ground	658	5
DTC 112: IAT voltage low	105	4	DTC 283: Injector 8 coil shorted	658	6
DTC 113: IAT voltage high	105	3	DTC 285: Injector 9 open or short to ground	659	5
DTC 116: ECT higher than expected stage 1	110	15	DTC 286: Injector 9 coil shorted	659	6
DTC 117: ECT voltage low	110	4	DTC 288: Injector 10 open or short to ground	660	5
DTC 118: ECT voltage high	110	3	DTC 289: Injector 10 coil shorted	660	6
DTC 121: TPS1-2 lower than expected	51	1	DTC 1631: PWM1-Gauge1 open / ground short	697	5
DTC 122: TPS1 voltage low	51	4	DTC 299: Boost control underboost failure	1692	1
DTC 123: TPS1 voltage high	51	3	DTC301: Cylinder 1 emissions/catalystdamagingmisfire	1323	31
DTC 127: IAT higher than expected stage 2	105	0	DTC302: Cylinder 2 emissions/catalystdamagingmisfire	1324	31
DTC 129: BP pressure low	108	1	DTC303: Cylinder 3 emissions/catalystdamagingmisfire	1325	31
DTC 134: EGO1 open / lazy	724	10	DTC304: Cylinder 4 emissions/catalystdamagingmisfire	1326	31
DTC 140: EGO3 open / lazy	520209	10	DTC305: Cylinder 5 emissions/catalystdamagingmisfire	1327	31
DTC 154: EGO2 open / lazy	520208	10	DTC306: Cylinder 6 emissions/catalystdamagingmisfire	1328	31
DTC 160: EGO4 open / lazy	520210	10	DTC307: Cylinder 7 emissions/catalystdamagingmisfire	1329	31
DTC 171: Adaptive-learn gasoline bank1 high	520200	0	DTC308: Cylinder 8 emissions/catalystdamagingmisfire	1330	31
DTC 172: Adaptive-learn gasoline bank1 low	520200	1	DTC 326: Knock1 excessive or erratic signal	731	2
DTC 174: Adaptive-learn gasoline bank2 high	520201	0	DTC 327: Knock1 sensor open or not present	731	4
DTC 175: Adaptive-learn gasoline bank2 low	520201	1	DTC 331: Knock2 excessive or erratic signal	520241	2
DTC 182: FT low voltage	174	4	DTC 332: Knock2 sensor open or not present	520241	4
DTC 183: FT high voltage	174	3	DTC 336: CRANK input signal noise	636	2
DTC 187: Gaseous fuel temperature sender low voltage	520240	4	DTC 337: Crank signal loss	636	4
DTC188:Gaseousfueltemperaturesenderhighvoltage	520240	3	DTC 341: CAM input signal noise	723	2
DTC 217: ECT higher than expected stage 2	110	0	DTC 342: Loss of CAM input signal	723	4
DTC 219: RPM higher than max allowed govern speed	515	15	DTC 359: Fuel run-out longer than expected	1239	7
DTC 221: TPS1-2 higher than expected	51	0	DTC 420: Catalyst inactive on gasoline (Bank 1)	520211	10
DTC 222: TPS2 voltage low	520251	4	DTC 430: Catalyst inactive on gasoline (Bank 2)	520212	10
DTC 223: TPS2 voltage high	520251	3	DTC 502: Roadspeed input loss of signal	84	1
DTC 234: Boost control overboost failure	1692	0	DTC 508: IAC ground short	520252	6
DTC 236: TIP active	1692	2	DTC 509: IAC coil open/short	520252	5
DTC 237: TIP low voltage	1127	4	DTC 520: Oil pressure sender low pressure stage 1	100	18
DTC 238: TIP high voltage	1127	3	DTC 521: Oil pressure sender high pressure	100	0
DTC 261: Injector 1 open or short to ground	651	5	DTC 522: Oil pressure sender low voltage	100	4
DTC 262: Injector 1 coil shorted	651	6	DTC 523: Oil pressure sender high voltage	100	3
DTC 264: Injector 2 open or short to ground	652	5	DTC 524: Oil pressure low	100	1
DTC 265: Injector 2 coil shorted	652	6	DTC 562: Vbat voltage low	168	17
DTC 267: Injector 3 open or short to ground	653	5	DTC 563: Vbat voltage high	168	15

DIAGNOSTIC TROUBLE CODE (DTC) CHART – SORTED BY DTC # (95 of

Description	DTC Set 2		Description	DTC Set 2	
	SPN-2	FMI-2		SPN-2	FMI-2
DTC 601: Microprocessor failure - FLASH	628	13	DTC 1175: MegaJector voltage supply low	520260	4
DTC 604: Microprocessor failure - RAM	630	12	DTC 1176: MegaJector internal actuator fault detection	520260	12
DTC 606: Microprocessor failure - COP	629	31	DTC 1177: MegaJector internal circuitry fault detection	520260	12
DTC 615: Start relay coil open	1321	5	DTC 1178: MegaJector internal comm fault detection	520260	12
DTC 616: Start relay ground short	1321	4	DTC 1182: Fuel impurity level high	520401	0
DTC 617: Start relay coil short to power	1321	3	DTC 1183: MegaJector autozero / lockoff failure	520803	31
DTC 627: Fuel pump relay coil open	1348	5	DTC 1311: Cylinder 1 misfire detected	1323	11
DTC 628: Fuel-pump high-side open or short to ground	1347	5	DTC 1312: Cylinder 2 misfire detected	1324	11
DTC 628: Fuel pump relay control ground short	1348	4	DTC 1313: Cylinder 3 misfire detected	1325	11
DTC 629: Fuel-pump high-side short to power	1347	6	DTC 1314: Cylinder 4 misfire detected	1326	11
DTC 629: Fuel pump relay coil short to power	1348	3	DTC 1315: Cylinder 5 misfire detected	1327	11
DTC 642: Sensor supply voltage 1 low	1079	4	DTC 1316: Cylinder 6 misfire detected	1328	11
DTC 643: Sensor supply voltage 1 high	1079	3	DTC 1317: Cylinder 7 misfire detected	1329	11
DTC 650: MIL open	1213	5	DTC 1318: Cylinder 8 misfire detected	1330	11
DTC 652: Sensor supply voltage 2 low	1080	4	DTC 1411: EMWT1 voltage high	441	3
DTC 653: Sensor supply voltage 2 high	1080	3	DTC 1412: EMWT2 voltage high	442	3
DTC 685: Power relay coil open	1485	5	DTC 1413: EMWT1 voltage low	441	4
DTC 686: Power relay ground short	1485	4	DTC 1414: EMWT2 voltage low	442	4
DTC 687: Power relay coil short to power	1485	3	DTC 1415: EMWT1 higher than expected stage 1	441	15
DTC 916: Shift actuator feedback out-of-range	520226	3	DTC 1416: EMWT2 higher than expected stage 1	442	15
DTC 919: Shift unable to reach desired gear	520226	7	DTC 1417: EMWT1 higher than expected stage 2	441	0
DTC 920: Shift actuator or drive circuit failed	520226	31	DTC 1418: EMWT2 higher than expected stage 2	442	0
DTC 1111: RPM above fuel rev limit level	515	16	DTC 1419: ERWT1 voltage high	443	3
DTC 1112: RPM above spark rev limit level	515	0	DTC 1420: ERWT2 voltage high	444	3
DTC 1121: FPP1/2 simultaneous voltages out-of-range (redundan	91	31	DTC 1421: ERWT1 voltage low	443	4
DTC 1122: FPP1/2 do not match each other or IVS (redundancy lo	520250	31	DTC 1422: ERWT2 voltage low	444	4
DTC 1131: WGP voltage high	1192	3	DTC 1423: ERWT1 higher than expected stage 1	443	15
DTC 1132: WGP voltage low	1192	4	DTC 1424: ERWT2 higher than expected stage 1	444	15
DTC 1151: Closed-loop LPG high	520206	0	DTC 1425: ERWT1 higher than expected stage 2	443	0
DTC 1152: Closed-loop LPG low	520206	1	DTC 1426: ERWT2 higher than expected stage 2	444	0
DTC 1153: Closed-loop NG high	520207	0	DTC 1511: AUX analog Pull-Up 1 high voltage	520216	3
DTC 1154: Closed-loop NG low	520207	1	DTC 1512: AUX analog Pull-Up 1 low voltage	520216	4
DTC 1155: Closed-loop gasoline bank1 high	520204	0	DTC 1513: AUX analog Pull-Up 2 high voltage	520217	3
DTC 1156: Closed-loop gasoline bank1 low	520204	1	DTC 1514: AUX analog Pull-Up 2 low voltage	520217	4
DTC 1157: Closed-loop gasoline bank2 high	520205	0	DTC 1515: AUX analog Pull-Down 1 high voltage	520215	3
DTC 1158: Closed-loop gasoline bank2 low	520205	1	DTC 1516: AUX analog Pull-Down 1 low voltage	520215	4
DTC 1161: Adaptive-learn LPG high	520202	0	DTC 1517: AUX analog Pull-Up 3 high voltage	520218	3
DTC 1162: Adaptive-learn LPG low	520202	1	DTC 1518: AUX analog Pull-Up 3 low voltage	520218	4
DTC 1163: Adaptive-learn NG high	520203	0	DTC 1521: CHT higher than expected stage 1	110	16
DTC 1164: Adaptive-learn NG low	520203	1	DTC 1522: CHT higher than expected stage 2	110	0
DTC 1165: Catalyst inactive on LPG	520213	10	DTC 1531: Gov1/2/3 interlock failure	520270	31
DTC 1166: Catalyst inactive on NG	520214	10	DTC 1541: AUX analog Pull-Up/Down 1 high voltage	520219	3
DTC1171:MegaJectordeliverypressurehigherthanexpected	520260	0	DTC 1542: AUX analog Pull-Up/Down 1 low voltage	520219	4
DTC 1172: MegaJectordeliverypressurelowerthanexpected	520260	1	DTC 1543: AUX analog Pull-Up/Down 2 high voltage	520220	3
DTC 1173: MegaJector comm lost	520260	31	DTC 1544: AUX analog Pull-Up/Down 2 low voltage	520220	4
DTC 1174: MegaJector voltage supply high	520260	3	DTC 1545: AUX analog Pull-Up/Down 3 high voltage	520221	3

DIAGNOSTIC TROUBLE CODE (DTC) CHART – **SORTED BY DTC # (96 of**

Description	DTC Set 2		Description	DTC Set 2	
	SPN-2	FMI-2		SPN-2	FMI-2
DTC 1546: AUX analog Pull-Up/Down 3 low voltage	520221	4	DTC 1662: PWM6 short to power	925	3
DTC 1547: AUX analog Pull-Up/Down 4 high voltage	713	3	DTC 1663: PWM7 open / ground short	926	5
DTC 1548: AUX analog Pull-Up/Down 4 low voltage	713	4	DTC 1664: PWM7 short to power	926	3
DTC 1551: AUX digital 1 high voltage	520222	3	DTC 1665: PWM8 open / ground short	2646	5
DTC 1552: AUX digital 1 low voltage	520222	4	DTC 1666: PWM8 short to power	2646	3
DTC 1553: AUX digital 2 high voltage	520223	3	DTC 1669: PWM9 open / ground short	2647	5
DTC 1554: AUX digital 2 low voltage	520223	4	DTC 1670: PWM9 short to power	2647	3
DTC 1555: AUX digital 3 high voltage	520224	3	DTC 2111: Unable to reach lower TPS	51	7
DTC 1555: Water Intrusion Detection	520224	3	DTC 2112: Unable to reach higher TPS	51	7
DTC 1556: AUX digital 3 low voltage	520224	4	DTC 2115: FPP1 higher than IVS	91	0
DTC 1561: AUX analog Pull-Down 2 high voltage	0	3	DTC 2116: FPP2 higher than IVS	29	0
DTC 1561: AUX analog Pull-Down 3 high voltage	0	3	DTC 2120: FPP1 invalid voltage and FPP2 disagrees with IVS	520250	31
DTC 1561: AUX analog Pull-Down 2 low voltage	0	4	DTC 2121: FPP1-2 lower than expected	91	18
DTC 1561: AUX analog Pull-Down 3 low voltage	0	4	DTC 2122: FPP1 voltage high	91	3
DTC 1611: Sensor supply voltage 1 and 2 out-of-range	1079	31	DTC 2123: FPP1 voltage low	91	4
DTC 1612: Microprocessor failure - RTI 1	629	31	DTC 2125: FPP2 invalid voltage and FPP1 disagrees with IVS	520250	31
DTC 1613: Microprocessor failure - RTI 2	629	31	DTC 2126: FPP1-2 higher than expected	91	16
DTC 1614: Microprocessor failure - RTI 3	629	31	DTC 2127: FPP2 voltage low	29	4
DTC 1615: Microprocessor failure - A/D	629	31	DTC 2128: FPP2 voltage high	29	3
DTC 1616: Microprocessor failure - Interrupt	629	31	DTC 2130: IVS stuck at-idle, FPP1/2 match	558	5
DTC 1621: RS-485 Rx inactive	0	31	DTC 2131: IVS stuck off-idle, FPP1/2 match	558	6
DTC 1622: RS-485 Rx noise	0	31	DTC 2135: TPS1/2 simultaneous voltages out-of-range	51	31
DTC 1623: RS-485 Rx bad packet format	0	31	DTC 2139: FPP1 lower than IVS	91	1
DTC 1624: RS-485 remote shutdown request	0	31	DTC 2140: FPP2 lower than IVS	29	1
DTC 1625: J1939 shutdown request	1384	31	DTC 2229: BP pressure high	108	0
DTC 1626: CAN-J1939 Tx fault	639	12	DTC2300: Sparkcoil 1 primary open or short to ground	1268	5
DTC 1627: CAN-J1939 Rx fault	639	12	DTC 2301: Spark coil 1 primary shorted	1268	6
DTC 1628: J1939 CAN address / engine-number conflict	639	13	DTC2303: Sparkcoil 2 primary open or short to ground	1269	5
DTC 1629: J1939 TSC1 message receipt loss	639	9	DTC 2304: Spark coil 2 primary shorted	1269	6
DTC 1630: J1939 ETC message receipt loss	91	2	DTC2306: Sparkcoil 3 primary open or short to ground	1270	5
DTC 1632: PWM1-Gauge1 short to power	697	6	DTC 2307: Spark coil 3 primary shorted	1270	6
DTC 1633: PWM2-Gauge2 open / ground short	698	5	DTC2309: Sparkcoil 4 primary open or short to ground	1271	5
DTC 1634: PWM2-Gauge2 short to power	698	6	DTC 2310: Spark coil 4 primary shorted	1271	6
DTC 1635: PWM3-Gauge3 open / ground short	699	5	DTC2312: Sparkcoil 5 primary open or short to ground	1272	5
DTC 1636: PWM3-Gauge3 short to power	699	6	DTC 2313: Spark coil 5 primary shorted	1272	6
DTC 1637: PWM4 open / ground short	700	5	DTC2315: Sparkcoil 6 primary open or short to ground	1273	5
DTC 1638: PWM4 short to power	700	6	DTC 2316: Spark coil 6 primary shorted	1273	6
DTC 1639: PWM5 open / ground short	520230	5	DTC2318: Sparkcoil 7 primary open or short to ground	1274	5
DTC 1640: PWM5 short to power	520230	6	DTC 2319: Spark coil 7 primary shorted	1274	6
DTC 1641: Buzzer control ground short	920	4	DTC2321: Sparkcoil 8 primary open or short to ground	1275	5
DTC 1642: Buzzer open	920	5	DTC 2322: Spark coil 8 primary shorted	1275	6
DTC 1643: Buzzer control short to power	920	3	DTC2324: Sparkcoil 9 primary open or short to ground	1276	5
DTC 1644: MIL control ground short	1213	4	DTC 2325: Spark coil 9 primary shorted	1276	6
DTC 1645: MIL control short to power	1213	3	DTC2327: Sparkcoil 10 primary open or short to ground	1277	5
DTC1651: J1939 ETC message receipt loss while in-gear	91	9	DTC 2328: Spark coil 10 primary shorted	1277	6
DTC 1661: PWM6 open / ground short	925	5	DTC 2428: EGT temperature high	173	0

DIAGNOSTIC TROUBLE CODE (DTC) CHART – SORTED BY DTC # (97 of

Description	DTC Set 2	
	SPN-2	FMI-2
DTC 2618: Tach output ground short	645	4
DTC 2619: Tach output short to power	645	3
DTC 8901: UEGO microprocessor internal fault	3221	31
DTC 8902: UEGO heater supply high voltage	3222	3
DTC 8903: UEGO heater supply low voltage	3222	4
DTC 8904: UEGO cal resistor voltage high	3221	3
DTC 8905: UEGO cal resistor voltage low	3221	4
DTC 8906: UEGO return voltage shorted high	3056	3
DTC 8907: UEGO return voltage shorted low	3056	4
DTC 8908: UEGO pump voltage shorted high	3218	3
DTC 8909: UEGO pump voltage shorted low	3218	4
DTC 8910: UEGO sense cell voltage high	3217	3
DTC 8911: UEGO sense cell voltage low	3217	4
DTC 8912: UEGO pump voltage at high drive limit	3225	3
DTC 8913: UEGO pump voltage at low drive limit	3225	4
DTC 8914: UEGO sense cell slow to warm up	3222	10
DTC 8915: UEGO pump cell slow to warm up	3225	10
DTC 8916: UEGO sense cell impedance high	3222	0
DTC 8917: UEGO pump cell impedance high	3225	0
DTC 8918: UEGO pump cell impedance low	3225	1

DIAGNOSTIC TROUBLE CODE (DTC) CHART – SORTED BY SPN:FMI (98 of

Description	DTC Set 2		Description	DTC Set 2	
	SPN-2	FMI-2		SPN-2	FMI-2
DTC 1561: AUXanalogPull-Down2highvoltage	0	3	DTC 107: MAP voltage low	106	4
DTC 1561: AUXanalogPull-Down3highvoltage	0	3	DTC 108: MAP pressure high	106	16
DTC 1561: AUXanalogPull-Down2lowvoltage	0	4	DTC 2229: BP pressure high	108	0
DTC 1561: AUXanalogPull-Down3lowvoltage	0	4	DTC 129: BP pressure low	108	1
DTC 1621: RS-485 Rx inactive	0	31	DTC 1522: CHT higher than expected stage 2	110	0
DTC 1622: RS-485 Rx noise	0	31	DTC 217: ECT higher than expected stage 2	110	0
DTC 1623: RS-485 Rx bad packet format	0	31	DTC 118: ECT voltage high	110	3
DTC 1624: RS-485 remote shutdown request	0	31	DTC 117: ECT voltage low	110	4
Undefined DTC - Index 10297	0	31	DTC 116: ECT higher than expected stage 1	110	15
Undefined DTC - Index 10298	0	31	DTC 1521: CHT higher than expected stage 1	110	16
Undefined DTC - Index 10299	0	31	DTC 563: Vbat voltage high	168	15
DTC 2116: FPP2 higher than IVS	29	0	DTC 562: Vbat voltage low	168	17
DTC 2140: FPP2 lower than IVS	29	1	DTC 2428: EGT temperature high	173	0
DTC 2128: FPP2 voltage high	29	3	DTC 183: FT high voltage	174	3
DTC 2127: FPP2 voltage low	29	4	DTC 182: FT low voltage	174	4
DTC 221: TPS1-2 higher than expected	51	0	DTC 1417: EMWT1 higher than expected stage 2	441	0
DTC 121: TPS1-2 lower than expected	51	1	DTC 1411: EMWT1 voltage high	441	3
DTC 123: TPS1 voltage high	51	3	DTC 1413: EMWT1 voltage low	441	4
DTC 122: TPS1 voltage low	51	4	DTC 1415: EMWT1 higher than expected stage 1	441	15
DTC 2112: Unable to reach higher TPS	51	7	DTC 1418: EMWT2 higher than expected stage 2	442	0
DTC 2111: Unable to reach lower TPS	51	7	DTC 1412: EMWT2 voltage high	442	3
DTC 2135: TPS1/2 simultaneous voltages out-of-ran	51	31	DTC 1414: EMWT2 voltage low	442	4
DTC 502: Roadspeed input loss of signal	84	1	DTC 1416: EMWT2 higher than expected stage 1	442	15
DTC 2115: FPP1 higher than IVS	91	0	DTC 1425: ERWT1 higher than expected stage 2	443	0
DTC 2139: FPP1 lower than IVS	91	1	DTC 1419: ERWT1 voltage high	443	3
DTC 1630: J1939 ETC message receipt loss	91	2	DTC 1421: ERWT1 voltage low	443	4
DTC 2122: FPP1 voltage high	91	3	DTC 1423: ERWT1 higher than expected stage 1	443	15
DTC 2123: FPP1 voltage low	91	4	DTC 1426: ERWT2 higher than expected stage 2	444	0
DTC 1651: J1939 ETC message receipt loss while i	91	9	DTC 1420: ERWT2 voltage high	444	3
DTC 2126: FPP1-2 higher than expected	91	16	DTC 1422: ERWT2 voltage low	444	4
DTC 2121: FPP1-2 lower than expected	91	18	DTC 1424: ERWT2 higher than expected stage 1	444	15
DTC 1121: FPP1/2 simultaneous voltages out-of-ran	91	31	DTC 1112: RPM above spark rev limit level	515	0
DTC 88 Fuel pressure higher than expected	94	0	DTC 219: RPMhigherthanmaxallowedgovernorspeed	515	15
DTC 87 Fuel pressure lower than expected	94	1	DTC 1111: RPM above fuel rev limit level	515	16
DTC 92: FP high voltage	94	3	DTC 2130: IVS stuck at-idle, FPP1/2 match	558	5
DTC 91: FP low voltage	94	4	DTC 2131: IVS stuck off-idle, FPP1/2 match	558	6
DTC 521: Oil pressure sender high pressure	100	0	DTC 601: Microprocessor failure - FLASH	628	13
DTC 524: Oil pressure low	100	1	DTC 606: Microprocessor failure - COP	629	31
DTC 524: Oil pressure sender low pressure	100	1	DTC 1612: Microprocessor failure - RTI 1	629	31
DTC 523: Oil pressure sender high voltage	100	3	DTC 1613: Microprocessor failure - RTI 2	629	31
DTC 522: Oil pressure sender low voltage	100	4	DTC 1614: Microprocessor failure - RTI 3	629	31
DTC 520: Oil pressure sender low pressure stage 1	100	18	DTC 1615: Microprocessor failure - A/D	629	31
DTC 127: IAT higher than expected stage 2	105	0	DTC 1616: Microprocessor failure - Interrupt	629	31
DTC 113: IAT voltage high	105	3	DTC 604: Microprocessor failure - RAM	630	12
DTC 112: IAT voltage low	105	4	DTC 336: CRANK input signal noise	636	2
DTC 111: IAT higher than expected stage 1	105	15	DTC 337: Crank signal loss	636	4

DIAGNOSTIC TROUBLE CODE (DTC) CHART – SORTED BY SPN:FMI (99 of

Description	DTC Set 2		Description	DTC Set 2	
	SPN-2	FMI-2		SPN-2	FMI-2
DTC 16: Crank and/or cam could not synchronized	636	8	DTC 1661: PWM6 open / ground short	925	5
DTC 1629: J1939 TSC1 message receipt loss	639	9	DTC 1664: PWM7 short to power	926	3
DTC 1626: CAN-J1939 Tx fault	639	12	DTC 1663: PWM7 open / ground short	926	5
DTC 1627: CAN-J1939 Rx fault	639	12	DTC 643: Sensor supply voltage 1 high	1079	3
DTC 1628: J1939 CAN address/engine-number co	639	13	DTC 642: Sensor supply voltage 1 low	1079	4
DTC 2619: Tach output short to power	645	3	DTC 1611: Sensor supply voltage 1 and 2 out-of-range	1079	31
DTC 2618: Tach output ground short	645	4	DTC 653: Sensor supply voltage 2 high	1080	3
DTC 261: Injector 1 open or short to ground	651	5	DTC 652: Sensor supply voltage 2 low	1080	4
DTC 262: Injector 1 coil shorted	651	6	DTC 238: TIP high voltage	1127	3
DTC 264: Injector 2 open or short to ground	652	5	DTC 237: TIP low voltage	1127	4
DTC 265: Injector 2 coil shorted	652	6	DTC 1131: WGP voltage high	1192	3
DTC 267: Injector 3 open or short to ground	653	5	DTC 1132: WGP voltage low	1192	4
DTC 268: Injector 3 coil shorted	653	6	DTC 1645: MIL control short to power	1213	3
DTC 270: Injector 4 open or short to ground	654	5	DTC 1644: MIL control ground short	1213	4
DTC 271: Injector 4 coil shorted	654	6	DTC 650: MIL open	1213	5
DTC 273: Injector 5 open or short to ground	655	5	DTC 359: Fuel run-out longer than expected	1239	7
DTC 274: Injector 5 coil shorted	655	6	DTC 2300: Sparkcoil 1 primary open or short to ground	1268	5
DTC 276: Injector 6 open or short to ground	656	5	DTC 2301: Spark coil 1 primary shorted	1268	6
DTC 277: Injector 6 coil shorted	656	6	DTC 2303: Sparkcoil 2 primary open or short to ground	1269	5
DTC 279: Injector 7 open or short to ground	657	5	DTC 2304: Spark coil 2 primary shorted	1269	6
DTC 280: Injector 7 coil shorted	657	6	DTC 2306: Sparkcoil 3 primary open or short to ground	1270	5
DTC 282: Injector 8 open or short to ground	658	5	DTC 2307: Spark coil 3 primary shorted	1270	6
DTC 283: Injector 8 coil shorted	658	6	DTC 2309: Sparkcoil 4 primary open or short to ground	1271	5
DTC 285: Injector 9 open or short to ground	659	5	DTC 2310: Spark coil 4 primary shorted	1271	6
DTC 286: Injector 9 coil shorted	659	6	DTC 2312: Sparkcoil 5 primary open or short to ground	1272	5
DTC 288: Injector 10 open or short to ground	660	5	DTC 2313: Spark coil 5 primary shorted	1272	6
DTC 289: Injector 10 coil shorted	660	6	DTC 2315: Sparkcoil 6 primary open or short to ground	1273	5
DTC 1631: PWM1-Gauge1 open/ground short	697	5	DTC 2316: Spark coil 6 primary shorted	1273	6
DTC 1632: PWM1-Gauge1 short to power	697	6	DTC 2318: Sparkcoil 7 primary open or short to ground	1274	5
DTC 1633: PWM2-Gauge2 open/ground short	698	5	DTC 2319: Spark coil 7 primary shorted	1274	6
DTC 1634: PWM2-Gauge2 short to power	698	6	DTC 2321: Sparkcoil 8 primary open or short to ground	1275	5
DTC 1635: PWM3-Gauge3 open/ground short	699	5	DTC 2322: Spark coil 8 primary shorted	1275	6
DTC 1636: PWM3-Gauge3 short to power	699	6	DTC 2324: Sparkcoil 9 primary open or short to ground	1276	5
DTC 1637: PWM4 open / ground short	700	5	DTC 2325: Spark coil 9 primary shorted	1276	6
DTC 1638: PWM4 short to power	700	6	DTC 2327: Spark coil 10 primary open or short to ground	1277	5
DTC 1547: AUX analog Pull-Up/Down 4 high voltag	713	3	DTC 2328: Spark coil 10 primary shorted	1277	6
DTC 1548: AUX analog Pull-Up/Down 4 low voltage	713	4	DTC 617: Start relay coil short to power	1321	3
DTC 341: CAM input signal noise	723	2	DTC 616: Start relay ground short	1321	4
DTC 342: Loss of CAM input signal	723	4	DTC 615: Start relay coil open	1321	5
DTC 134: EGO1 open / lazy	724	10	DTC 1311: Cylinder 1 misfire detected	1323	11
DTC 326: Knock1 excessive or erratic signal	731	2	DTC 301: Cylinder 1 emissions/catalyst damaging misfire	1323	31
DTC 327: Knock1 sensor open or not present	731	4	DTC 1312: Cylinder 2 misfire detected	1324	11
DTC 1643: Buzzer control short to power	920	3	DTC 302: Cylinder 2 emissions/catalyst damaging misfire	1324	31
DTC 1641: Buzzer control ground short	920	4	DTC 1313: Cylinder 3 misfire detected	1325	11
DTC 1642: Buzzer open	920	5	DTC 303: Cylinder 3 emissions/catalyst damaging misfire	1325	31
DTC 1662: PWM6 short to power	925	3	DTC 1314: Cylinder 4 misfire detected	1326	11

DIAGNOSTIC TROUBLE CODE (DTC) CHART – SORTED BY SPN:FMI (100 of

Description	DTC Set 2		Description	DTC Set 2	
	SPN-2	FMI-2		SPN-2	FMI-2
DTC 304: Cylinder 4 emissions/catalyst damaging m	1326	31	DTC 175: Adaptive-learn gasoline bank2 low	520201	1
DTC 1315: Cylinder 5 misfire detected	1327	11	DTC 1161: Adaptive-learn LPG high	520202	0
DTC 305: Cylinder 5 emissions/catalyst damaging m	1327	31	DTC 1162: Adaptive-learn LPG low	520202	1
DTC 1316: Cylinder 6 misfire detected	1328	11	DTC 1163: Adaptive-learn NG high	520203	0
DTC 306: Cylinder 6 emissions/catalyst damaging m	1328	31	DTC 1164: Adaptive-learn NG low	520203	1
DTC 1317: Cylinder 7 misfire detected	1329	11	DTC 1155: Closed-loop gasoline bank1 high	520204	0
DTC 307: Cylinder 7 emissions/catalyst damaging m	1329	31	DTC 1156: Closed-loop gasoline bank1 low	520204	1
DTC 1318: Cylinder 8 misfire detected	1330	11	DTC 1157: Closed-loop gasoline bank2 high	520205	0
DTC 308: Cylinder 8 emissions/catalyst damaging m	1330	31	DTC 1158: Closed-loop gasoline bank2 low	520205	1
DTC 628: Fuel-pumphigh-sideopen or short to grou	1347	5	DTC 1151: Closed-loop LPG high	520206	0
DTC 629: Fuel-pump high-side short to power	1347	6	DTC 1152: Closed-loop LPG low	520206	1
DTC 629: Fuel pump relay coil short to power	1348	3	DTC 1153: Closed-loop NG high	520207	0
DTC628:Fuelpumprelaycontrolground short	1348	4	DTC 1154: Closed-loop NG low	520207	1
DTC 627: Fuel pump relay coil open	1348	5	DTC 154: EGO2 open / lazy	520208	10
DTC 1625: J1939 shutdown request	1384	31	DTC 140: EGO3 open / lazy	520209	10
DTC 687: Power relay coil short to power	1485	3	DTC 160: EGO4 open / lazy	520210	10
DTC 686: Power relay ground short	1485	4	DTC 420: Catalyst inactive on gasoline (Bank 1)	520211	10
DTC 685: Power relay coil open	1485	5	DTC 430: Catalyst inactive on gasoline (Bank 2)	520212	10
DTC 234: Boost control overboost failure	1692	0	DTC 1165: Catalyst inactive on LPG	520213	10
DTC 299: Boost control underboost failure	1692	1	DTC 1166: Catalyst inactive on NG	520214	10
DTC 236: TIP active	1692	2	DTC 1515: AUX analog Pull-Down 1 high voltage	520215	3
DTC 1666: PWM8 short to power	2646	3	DTC 1516: AUX analog Pull-Down 1 low voltage	520215	4
DTC 1665: PWM8 open / ground short	2646	5	DTC 1511: AUX analog Pull-Up 1 high voltage	520216	3
DTC 1670: PWM9 short to power	2647	3	DTC 1512: AUX analog Pull-Up 1 low voltage	520216	4
DTC 1669: PWM9 open / ground short	2647	5	DTC 1513: AUX analog Pull-Up 2 high voltage	520217	3
DTC 8906: UEGO return voltage shorted high	3056	3	DTC 1514: AUX analog Pull-Up 2 low voltage	520217	4
DTC 8907: UEGO return voltage shorted low	3056	4	DTC 1517: AUX analog Pull-Up 3 high voltage	520218	3
DTC 8910: UEGO sense cell voltage high	3217	3	DTC 1518: AUX analog Pull-Up 3 low voltage	520218	4
DTC 8911: UEGO sense cell voltage low	3217	4	DTC1541:AUXanalog Pull-Up/Down 1 highvoltage	520219	3
DTC 8908: UEGO pump voltage shorted high	3218	3	DTC 1542: AUX analog Pull-Up/Down 1 low voltage	520219	4
DTC 8909: UEGO pump voltage shorted low	3218	4	DTC1543:AUXanalog Pull-Up/Down 2 high voltage	520220	3
DTC 8904: UEGO cal resistor voltage high	3221	3	DTC 1544: AUX analog Pull-Up/Down 2 low voltage	520220	4
DTC 8905: UEGO cal resistor voltage low	3221	4	DTC1545:AUXanalog Pull-Up/Down 3 highvoltage	520221	3
DTC 8901: UEGO microprocessor internal fault	3221	31	DTC 1546: AUX analog Pull-Up/Down 3 low voltage	520221	4
DTC 8916: UEGO sense cell impedance high	3222	0	DTC 1551: AUX digital 1 high voltage	520222	3
DTC 8902: UEGO heater supply high voltage	3222	3	DTC 1552: AUX digital 1 low voltage	520222	4
DTC 8903: UEGO heater supply low voltage	3222	4	DTC 1553: AUX digital 2 high voltage	520223	3
DTC 8914: UEGO sense cell slow to warm up	3222	10	DTC 1554: AUX digital 2 low voltage	520223	4
DTC 8917: UEGO pump cell impedance high	3225	0	DTC 1555: AUX digital 3 high voltage	520224	3
DTC 8918: UEGO pump cell impedance low	3225	1	DTC 1555: Water Intrusion Detection	520224	3
DTC 8912: UEGO pump voltage at high drive limit	3225	3	DTC 1556: AUX digital 3 low voltage	520224	4
DTC 8913: UEGO pump voltage at low drive limit	3225	4	DTC 916: Shift actuator feedback out-of-range	520226	3
DTC 8915: UEGO pump cell slow to warm up	3225	10	DTC 919: Shift unable to reach desired gear	520226	7
DTC 171: Adaptive-learn gasoline bank1 high	520200	0	DTC 920: Shift actuator or drive circuit failed	520226	31
DTC 172: Adaptive-learn gasoline bank1 low	520200	1	DTC 1639: PWM5 open / ground short	520230	5
DTC 174: Adaptive-learn gasoline bank2 high	520201	0	DTC 1640: PWM5 short to power	520230	6

DIAGNOSTIC TROUBLE CODE (DTC) CHART – SORTED BY SPN:FMI 4 of 4)

Description	DTC Set 2	
	SPN-2	FMI-2
DTC 188: Gaseous fuel temperature sender high vo	520240	3
DTC 187: Gaseous fuel temperature sender low volt	520240	4
DTC 331: Knock2 excessive or erratic signal	520241	2
DTC 332: Knock2 sensor open or not present	520241	4
DTC 2120: FPP1 invalid voltage and FPP2 disagree	520250	31
DTC 2125: FPP2 invalid voltage and FPP1 disagree	520250	31
DTC 1122: FPP1/2 do not match each other or IVS (520250	31
DTC 223: TPS2 voltage high	520251	3
DTC 222: TPS2 voltage low	520251	4
DTC 509: IAC coil open/short	520252	5
DTC 508: IAC ground short	520252	6
DTC 1171: MegaJector delivery pressure higher tha	520260	0
DTC 1172: MegaJector delivery pressure lower than	520260	1
DTC 1174: MegaJector voltage supply high	520260	3
DTC 1175: MegaJector voltage supply low	520260	4
DTC 1176: MegaJector internal actuator fault detect	520260	12
DTC 1177: MegaJector internal circuitry fault detecti	520260	12
DTC 1178: MegaJector internal comm fault detectio	520260	12
DTC 1173: MegaJector comm lost	520260	31
DTC 1531: Gov1/2/3 interlock failure	520270	31
DTC 1182: Fuel impurity level high	520401	0
DTC 11: Intake cam / distributor position error	520800	7
DTC 24: Exhaust cam position error	520801	7
DTC 1183: MegaJector autozero / lockoff failure	520803	31

OBD System Check/MIL (Malfunction Indicator Lamp)

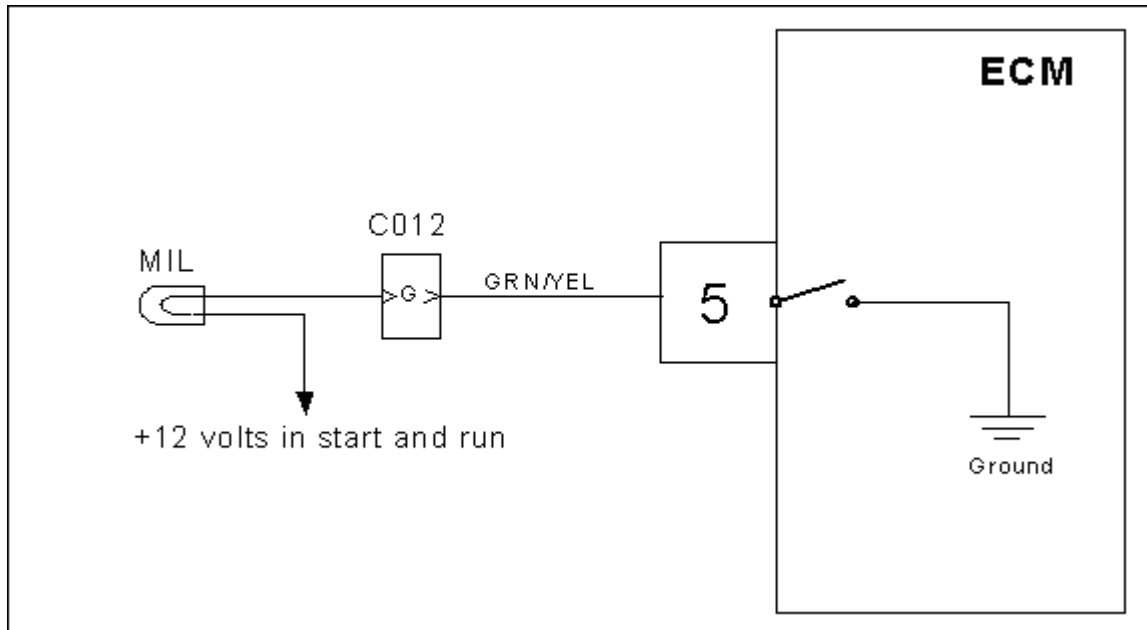

Circuit Description

The fuel system is equipped with OBD (On-Board Diagnostics). The system has a dash mounted MIL (Malfunction Indicator Lamp). The MIL serves as notification of an engine or fuel system related problem. The MIL also has the ability to flash DTC codes in what is referred to as the blink code mode. It will display DTCs that have been stored due to a possible system malfunction. The following DTC charts in this manual will instruct the technician to perform the OBD system check. This simply means to verify the operation of the MIL. The lamp should illuminate when the key is in the ON position, and the engine is not running. This feature verifies that the lamp is in proper working order. If the lamp does not illuminate with the vehicle key ON and engine OFF, repair it as soon as possible. Once the engine is in start or run mode, the lamp should go off. If the lamp stays on while the engine is in the start or run mode, a current diagnostic trouble code may be set or a problem may exist with the MIL electrical wiring. The electrical schematic above shows the MIL power source supplied to the lamp. The ECM completes the circuit to ground to turn the lamp ON.

DTC 16-Never Crank Synced at Start (SPN 636:FMI 8)

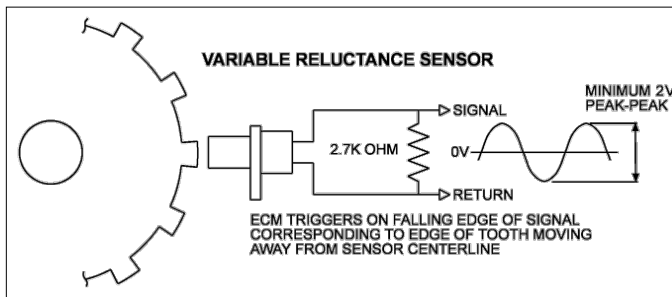
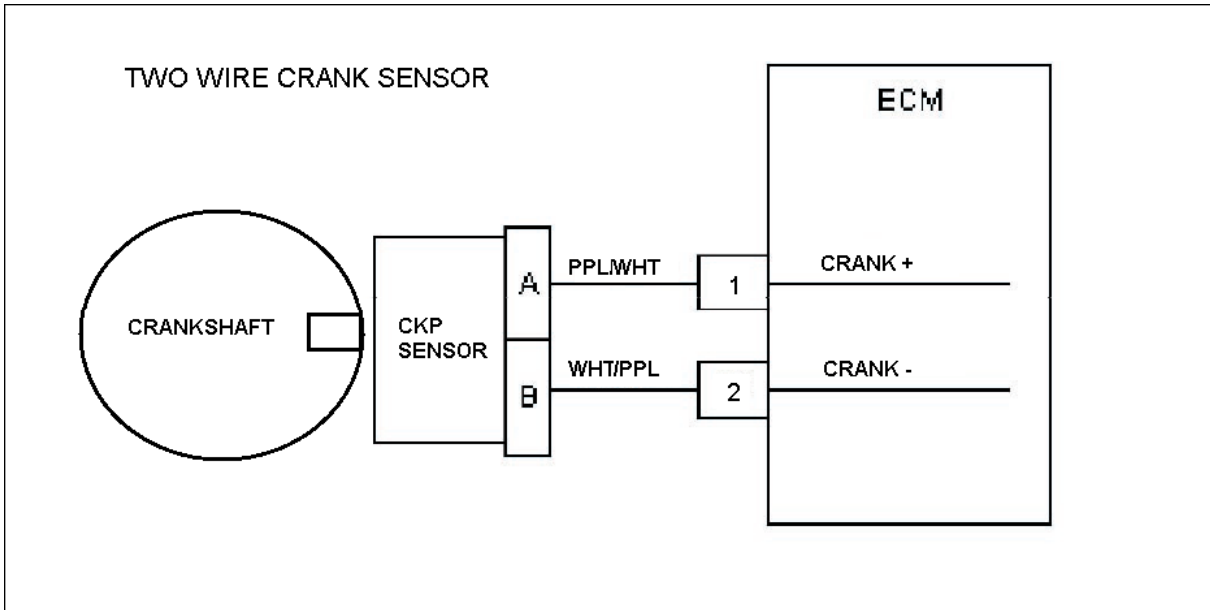

Conditions for setting the DTC

- Crankshaft Position sensor
- Check Condition- Engine cranking
- Fault Condition- Cranking RPM above 90 and more than 4 cranking revolutions without sync
- MIL Command-ON

Circuit Description

The CKP (crankshaft position sensor) is a magnetic transducer mounted on the engine block adjacent to a pulse wheel located on the crankshaft. It determines crankshaft position by monitoring the pulse wheel. The Crankshaft Position sensor is used to measure engine RPM and its signal is used to synchronize the ignition and fuel systems. This fault will set if 4 cranking revolutions have occurred and the no sync has occurred.

Step	Action	Value(s)	Yes	No
1	Did you perform the On-Board (OBD) System Check?	-	Go to Step (2)	Go to OBD System Check Section
2	<ul style="list-style-type: none"> Check to be sure that the ECM ground terminals C014 and C023 are clean and tight. Are terminals C014 and C023 clean and tight?		Go to Step (3)	Repair the circuit as necessary. Refer to Wiring Repairs in Engine Electrical
3	<ul style="list-style-type: none"> Key OFF Disconnect the CKP sensor connector C017 Using a DVOM check for voltage output directly from the CKP sensor while cranking the engine Do you have voltage output?	Over .5 volts	Go to Step (4)	Go to Step (11)
4	<ul style="list-style-type: none"> Key OFF Disconnect ECM connector C001 Using a DVOM check for continuity between CKP connector pin A and ECM connector pin 1 Do you have continuity between them?		Go to Step (5)	Repair the circuit as necessary. Refer to Wiring Repairs in Engine Electrical
5	<ul style="list-style-type: none"> Using a DVOM check for continuity between CKP connector pin B and ECM connector pin 2 Do you have continuity between them?		Go to Step (6)	Repair the circuit as necessary. Refer to Wiring Repairs in Engine Electrical
6	<ul style="list-style-type: none"> Inspect the CKP connector C017 pins for damage, corrosion or contamination Did you find a problem?		Repair the circuit as necessary. Refer to Wiring Repairs in Engine Electrical	Go to Step (7)
7	<ul style="list-style-type: none"> Inspect the ECM connector C001 pins 1 and 2 for damage, corrosion or contamination Did you find a problem?		Repair the circuit as necessary. Refer to Wiring Repairs in Engine Electrical	Go to step (8)
8	<ul style="list-style-type: none"> Using a DVOM check for continuity between ECM connector pins 1 and 2 to engine ground Do you have continuity?		Repair the shorted circuit as necessary. Refer to Wiring Repairs in Engine Electrical	Go to Step (10)

Step	Action	Value(s)	Yes	No
9	<ul style="list-style-type: none"> Replace CKP sensor <p>Is the replacement complete?</p>		Go to Step (12)	-
10	<ul style="list-style-type: none"> Replace ECM Is the replacement complete? 		Go to Step (12)	-
11	<ul style="list-style-type: none"> Key OFF Inspect the pulse wheel and CKP sensor for mechanical damage, corrosion or contamination. <p>Did you find a problem?</p>		Repair the component as necessary. Refer to Engine Repairs in Engine Section	Go to Step (9)
12	<ul style="list-style-type: none"> Remove all test equipment except the DST. Connect any disconnected components, fuses, etc. Using the DST clear DTC information from the ECM. Turn the ignition OFF and wait 30 seconds. Start the engine and operate the vehicle to full operating temperature Observe the MIL Observe engine performance and driveability After operating the engine within the test parameters of DIC-16 check for any stored codes. <p>Does the engine operate normally with no stored codes?</p>		System OK	Go to OBD System Check

DTC 107-MAP Low Voltage (SPN 106:FMI 4)

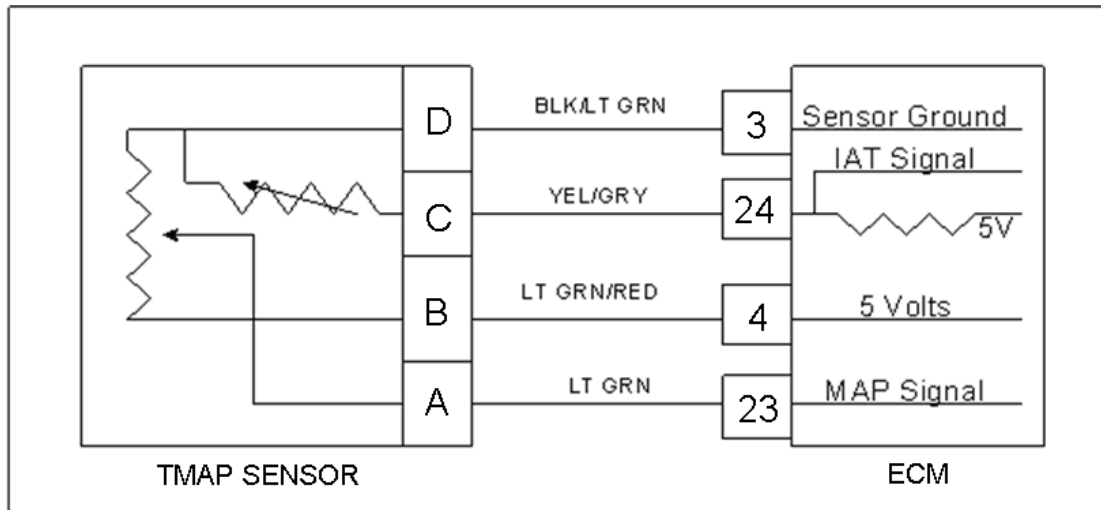

Conditions for Setting the DTC

- Manifold Absolute Pressure Sensor
- Check Condition-Engine cranking or running
- Fault Condition-MAP voltage less than 0.050 with throttle position greater than 2.0% and engine RPM less than 3000.
- MIL-ON
- Adaptive-Disabled
- Fueling is based on RPM and TPS Limp-Home Condition during this fault.

Circuit Description

The Manifold Absolute Pressure sensor is a pressure transducer connected to the intake manifold. It is used to measure the pressure of air in the manifold prior to induction. The pressure reading is used in conjunction with other inputs to estimate the airflow rate to the engine, which determines the fuel flow rate. This fault will set if the MAP voltage is less than 0.050 with TPS greater than 2% and engine RPM is less than 3000. The Adaptive Learn will be disabled for the remainder of the key on cycle and the MIL command is on.

DTC 107-MAP Low Voltage

Step	Action	Value(s)	Yes	No
1	Did you perform the On-Board (OBD) System Check?	-	Go to Step (2)	Go to OBD System Check Section
2	<ul style="list-style-type: none"> • Key ON, Engine running. • DSC (Diagnostic Scan Tool) connected in System Data Mode Does DST display MAP voltage of 0.050 or less with the engine running below 3000 rpm and TPS above 2.0 %?		Go to Step (3)	Intermittent problem Go to Intermittent section
3	<ul style="list-style-type: none"> • Key OFF • Disconnect the MAP sensor connector C006 from the wiring harness • Jump the 5 volt reference pin B and MAP signal circuit pin A together • Key ON Does the DST display MAP voltage of 4.5 volts or greater?		Go to Step (4)	Go to Step (8)
4	<ul style="list-style-type: none"> • Inspect MAP connector and pins for corrosion, contamination or mechanical damage Any problems found?		Repair the circuit as necessary. Refer to Wiring Repairs in Engine Electrical.	Go to Step (5)
5	<ul style="list-style-type: none"> • Key OFF • Disconnect ECM connector C001 • Check for continuity between MAP sensor connector signal pin A and ECM MAP signal pin 23. Do you have continuity between them?		Go to Step (6)	Repair the circuit as necessary. Refer to Wiring Repairs in Engine Electrical.
6	<ul style="list-style-type: none"> • Check for continuity between MAP sensor connector 5 volt supply signal pin B and ECM 5 volt supply pin 4 Do you have continuity between them?		Go to Step (7)	Repair the circuit as necessary. Refer to Wiring Repairs in Engine Electrical.
7	<ul style="list-style-type: none"> • Check for continuity between MAP sensor connector ground pin D and ECM sensor ground pin 3 Do you have continuity between them?		Go to Step (17)	Repair the circuit as necessary. Refer to Wiring Repairs in Engine Electrical.

Step	Action	Value(s)	Yes	No
8	<ul style="list-style-type: none"> Probe MAP connector signal circuit pin A with a test light connected to battery voltage. Does the DST display MAP voltage of 4.0 or greater?		Go to Step (9)	Go to Step (13)
9	<ul style="list-style-type: none"> Key OFF Disconnect ECM connector Check for continuity between MAP sensor connector pin B and ECM 5 volt pin 4. Do you have continuity between them?		Go to Step (10)	Repair the circuit as necessary. Refer to Wiring Repairs in Engine Electrical.
10	<ul style="list-style-type: none"> Check for continuity between MAP sensor connector 5 volt reference pin B and engine ground Do you have continuity?		Repair the circuit as necessary. Refer to Wiring Repairs in Engine Electrical.	Go to Step (11)
11	<ul style="list-style-type: none"> Inspect ECM and MAP wire harness connector and terminals for corrosion, contamination or mechanical damage Any problems found?		Repair the circuit as necessary. Refer to Wiring Repairs in Engine Electrical.	Go to Step (16)
12	<ul style="list-style-type: none"> Replace ECM. Refer to ECM replacement in the Engine Controls Section. Is the replacement complete?		Go to Step (17)	-
13	<ul style="list-style-type: none"> Disconnect ECM connector Check for continuity between MAP sensor connector signal circuit pin A and ECM signal pin 23. Do you have continuity between them?		Go to Step (14)	Repair the circuit as necessary. Refer to Wiring Repairs in Engine Electrical.
14	<ul style="list-style-type: none"> Check for continuity between MAP sensor connector signal pin A and engine ground Do you have continuity?		Repair the circuit as necessary. Refer to Wiring Repairs in Engine Electrical.	Go to Step (15)
15	<ul style="list-style-type: none"> Inspect ECM connector and wire harness connector terminals for corrosion, contamination or mechanical damage Any problems found?		Repair the circuit as necessary. Refer to Wiring Repairs in Engine Electrical.	Go to Step (16)

Step	Action	Value(s)	Yes	No
16	<ul style="list-style-type: none"> Replace ECM. Refer to ECM replacement in the Engine Controls Section. Is the replacement complete?		Go to Step (18)	-
17	<ul style="list-style-type: none"> Replace MAP sensor Is the replacement complete?		Go to Step (18)	-
18	<ul style="list-style-type: none"> Remove all test equipment except the DST. Connect any disconnected components, fuses, etc. Using the DST clear DTC information from the ECM. Turn the ignition OFF and wait 30 seconds. Start the engine and operate the vehicle to full operating temperature Observe the MIL Observe engine performance and drivability After operating the engine within the test parameters of DTC-107 check for any stored codes. Does the engine operate normally with no stored codes?		System OK	Go to OBD System Check

DTC 108-MAP High Pressure (SPN 106:FMI 16)

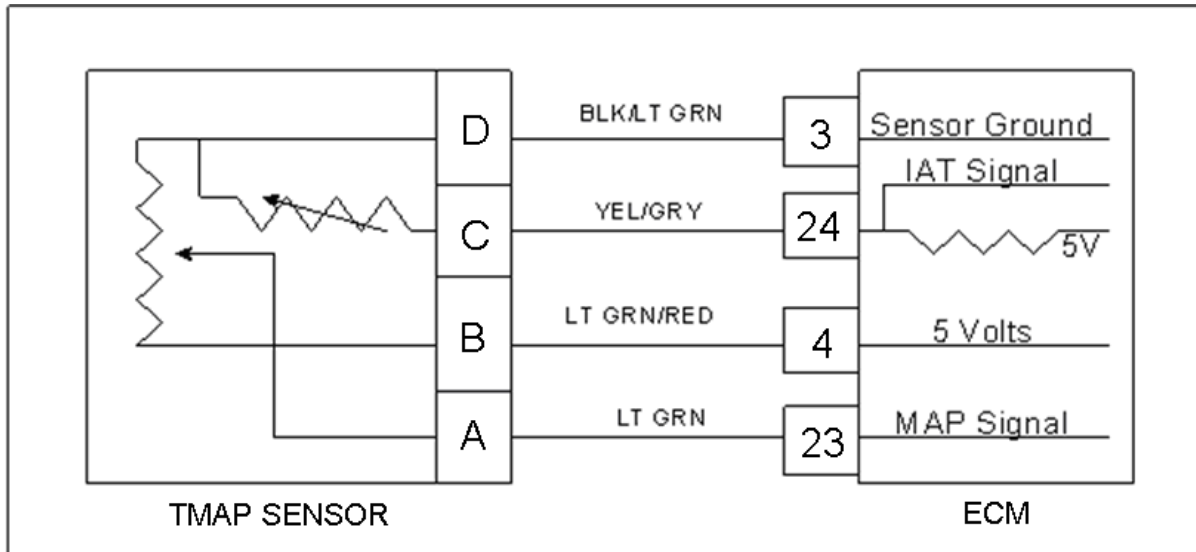

Conditions for Setting the DTC

- MAP pressure test
- Check condition-engine running
- Fault Condition-MAP greater than 17.00 psia with TPS less than 8% and engine rpm greater than 800.
- MIL-ON
- Adaptive-disabled

Circuit Description

The MAP (Manifold Absolute Pressure) is estimated from the MAP sensor. The MAP pressure value is used for fuel, airflow and spark calculations. This fault will set in the event the MAP value is greater than 17.00 psia when the TPS is less than 8% with engine rpm greater than 800.

DTC 108-MAP High Pressure

Step	Action	Value(s)	Yes	No
1	Did you perform the On-Board (OBD) System Check?	-	Go to Step (2)	Go to OBD System Check Section
2	<ul style="list-style-type: none"> • Key ON, Engine running at full operating temperature. • DST (Diagnostic Scan Tool) connected in System Data Mode Does DST display MAP pressure of 17 psia or greater with the engine running above 800 rpm with a TPS value less than 8%?		Go to Step (3)	Intermittent problem Go to Intermittent section
3	<ul style="list-style-type: none"> • Key OFF • Disconnect the MAP sensor connector C006 • Key ON Does the DST display MAP pressure less than 0.05 psia?		Go to Step (4)	Go to Step (6)
4	<ul style="list-style-type: none"> • Probe MAP connector ground pin D with a test light connected to battery voltage. Does the test light come on?		Go to Step (5)	Go to Step (8)
5	<ul style="list-style-type: none"> • Check MAP mechanical vacuum connection for correct mounting or possible damage causing leakage. Is the MAP sensor mechanical connection OK?		Go to Step (6)	Go to Step (10)
6	<ul style="list-style-type: none"> • Key OFF • Disconnect ECM connector and inspect terminals for damage corrosion or contamination. Is the connection OK?		Go to Step (7)	Repair the circuit as necessary. Refer to Wiring Repairs in Engine Electrical.
7	<ul style="list-style-type: none"> • Replace MAP sensor. Is the repair complete?	—	Go to Step (11)	-

Step	Action	Value(s)	Yes	No
8	<ul style="list-style-type: none"> Disconnect ECM connector and check for continuity between MAP connector sensor ground pin D and ECM sensor ground pin 3. Do you have continuity between them?		Go to Step (9)	Repair the circuit as necessary. Refer to Wiring Repairs in Engine Electrical.
9	<ul style="list-style-type: none"> Replace ECM. Refer to ECM replacement in the Engine Controls Section. Is the replacement complete?		Go to Step (11)	-
10	<ul style="list-style-type: none"> Correct MAP mechanical connection Has the MAP mechanical connection problem been corrected?		Go to Step (11)	-
11	<ul style="list-style-type: none"> Remove all test equipment except the DST. Connect any disconnected components, fuses, etc. Using the DST clear DTC information from the ECM. Turn the ignition OFF and wait 30 seconds. Start the engine and operate the vehicle to full operating temperature Observe the MIL Observe engine performance and drivability After operating the engine within the test parameters of DTC-108 check for any stored codes. Does the engine operate normally with no stored codes?		System OK	Go to OBD System Check

DTC 111-IAT Higher Than Expected 1 (SPN 105:FMI 15)

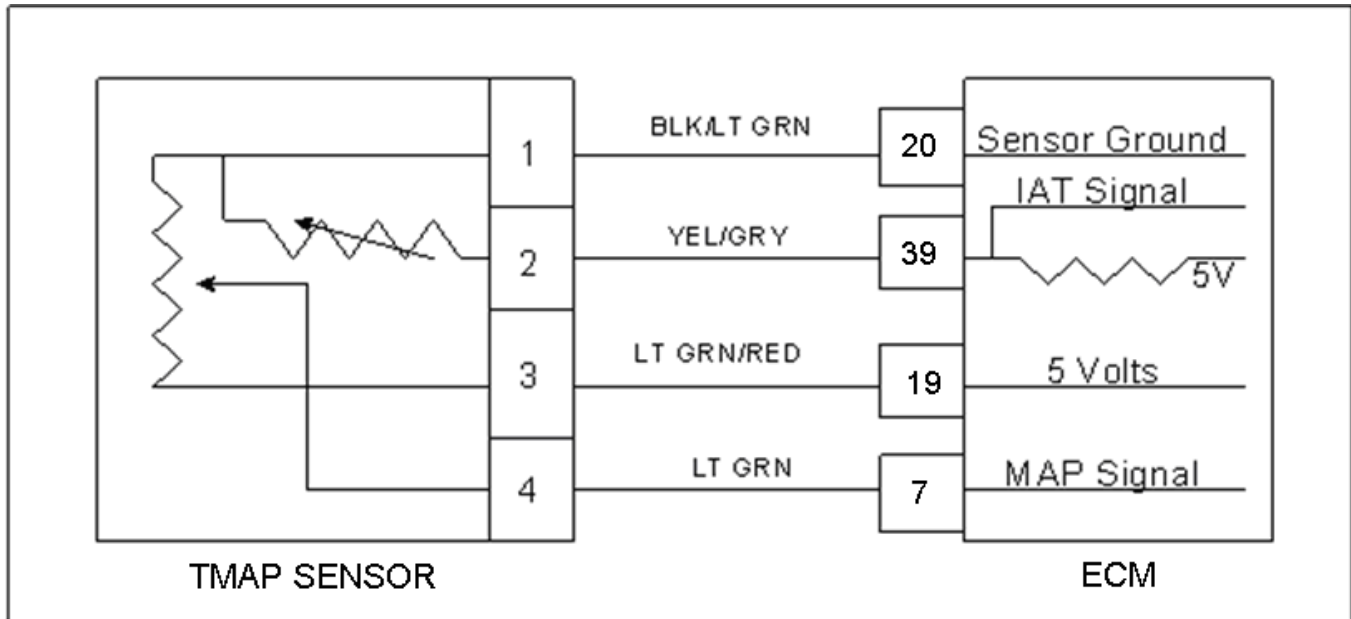

Conditions for Setting the DTC

- Intake Air Temperature
- Check Condition-Engine Running
- Fault Condition-Intake Air Temperature greater than 200 degrees F. with engine rpm greater than 600
- Condition must be present for a minimum of 60 seconds
- MIL-ON
- Forced Idle will occur
- Derate level 1 will occur

Circuit Description

The TMAP is a combined IAT (Intake Air Temperature) and MAP (Manifold Absolute Pressure) sensor. A temperature sensitive resistor is used in the TMAP located in the air intake manifold of the engine. It is used to monitor incoming air temperature, and the output in conjunction with other sensors is used to determine the airflow to the engine. The ECM provides a voltage divider circuit so that when the air is cool, the signal reads higher voltage, and lower when warm. This fault will set if the Intake Air Temperature is greater than 200 degrees F. with engine speed greater than 600 rpm. The engine will go into a level 1 derate mode to prevent engine damage. The engine will also go into a forced idle mode.

DTC 111-IAT Higher Than Expected 1 **(SPN 105:FMI 15)**

Diagnostic Aid

This fault will set when inlet air is much hotter than normal. The most common cause of high inlet air temperature is a problem with the inlet air system.

- Ensure that the air inlet is not obstructed, modified or damaged.
- Inspect the air inlet system for cracks or breaks that may allow unwanted under hood air in to the air inlet system
- If none of the above can be found, follow the diagnostic steps for DTC 112-IAT Low Voltage.

DTC 112-IAT Low Voltage (SPN 105:FMI 4)

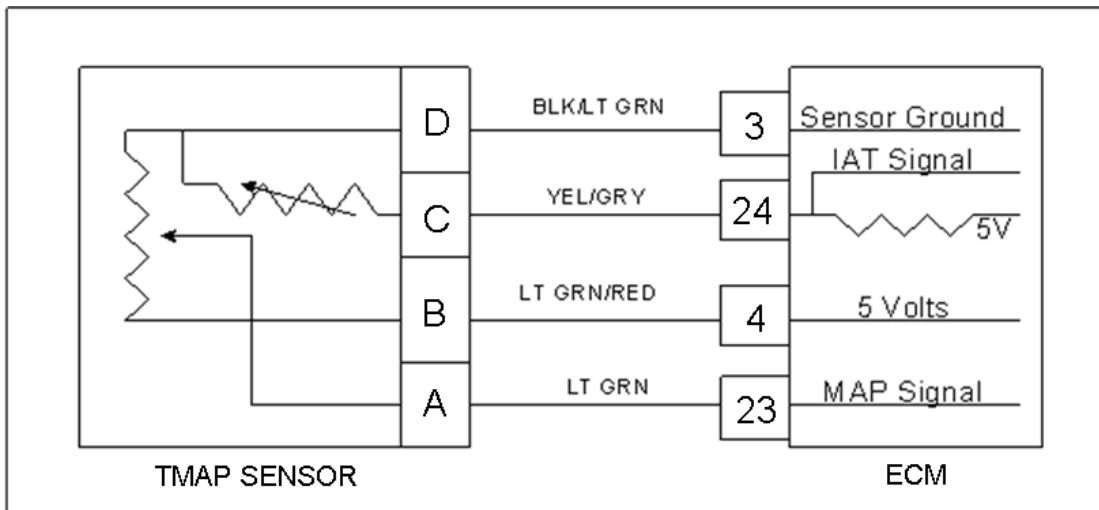

Conditions for Setting the DTC

- Intake Air Temperature
- Check Condition Engine Cranking or Running
- Fault Condition-IAT Sensor Voltage less than 0.050
- MIL-ON during active fault
- Adaptive-Disabled during active fault

Circuit Description

The TMAP is a combined IAT (Intake Air Temperature) and MAP (Manifold Absolute Pressure) sensor. A temperature sensitive resistor is used in the TMAP is located in the engine's air intake or intake manifold. It is used to monitor incoming air temperature, and the output in conjunction with other sensors is used to determine the airflow to the engine. The ECM provides a voltage divider circuit so that when the air is cool the signal reads higher voltage, and lower when warm. This fault will set if the signal voltage is less than 0.050 volts for 1 second anytime the engine is cranking or running. The ECM will use the default value for the IAT sensor in the event of this fault.

DTC 112-IAT Voltage Low

Step	Action	Value(s)	Yes	No
1	Did you perform the On-Board (OBD) System Check?	—	Go to Step (2)	Go to OBD System Check Section
2	<ul style="list-style-type: none"> • Key ON • DST (Diagnostic Scan Tool) connected in System Data Mode Does DST display IAT voltage of 0.050 or less?		Go to Step (3)	Intermittent problem Go to Intermittent section
3	<ul style="list-style-type: none"> • Key OFF • Disconnect the TMAP sensor connector. • Key ON Does the DST display IAT voltage of 4.90 volts or greater?		Go to Step (4)	Go to Step (5)
4	<ul style="list-style-type: none"> • Replace TMAP sensor. Is the replacement complete?		Go to Step (9)	—
5	<ul style="list-style-type: none"> • Key OFF • Disconnect ECM wire harness connector C001 • Check for continuity between TMAP sensor connector ground pin D and TMAP sensor connector signal pin C Do you have continuity between them?	—	Repair the circuit as necessary. Refer to Wiring Repairs in Engine Electrical.	Go to Step (6)
6	<ul style="list-style-type: none"> • Check for continuity between TMAP sensor connector signal circuit pin C and engine ground. Do you have continuity?	—	Repair the circuit as necessary. Refer to Wiring Repairs in Engine Electrical.	Go to Step (7)

Step	Action	Value(s)	Yes	No
7	<ul style="list-style-type: none"> • Replace ECM. Refer to ECM replacement in the Engine Controls Section. Is the replacement complete?	–	Go to Step (8)	–
8	<ul style="list-style-type: none"> • Remove all test equipment except the DST. • Connect any disconnected components fuses, etc. • Using the DST clear DTC information from the ECM. • Turn the ignition OFF and wait 30 seconds. • Start the engine and operate the vehicle to full operating temperature • Observe the MIL • Observe engine performance and drivability • After operating the engine within the test parameters of DTC-112 check for any stored codes. Does the engine operate normally with no stored codes?		System OK	Go to OBD System Check

DTC 113-IAT High Voltage (SPN 105:FMI 3)

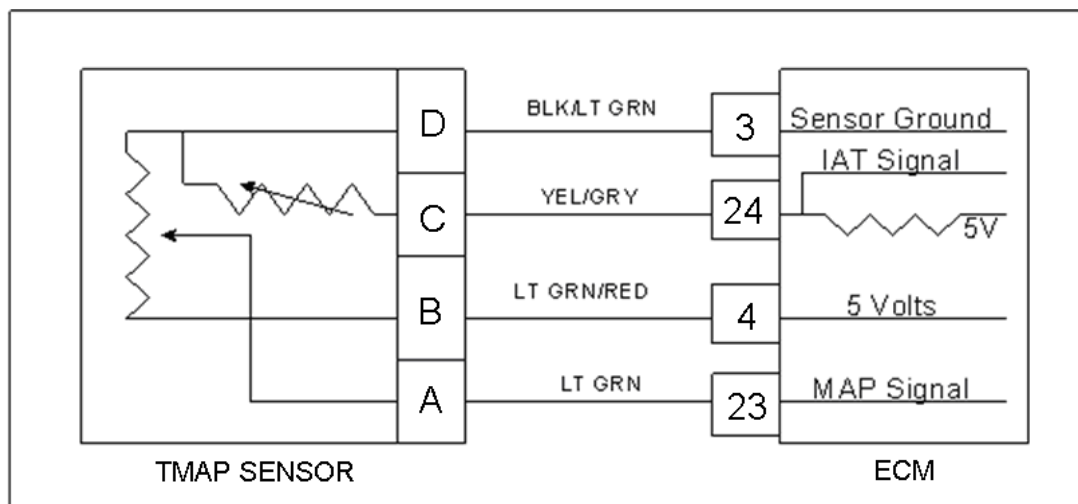

Conditions for Setting the DTC

- Intake Air Temperature
- Check Condition-Engine Running
- Fault Condition-IAT Sensor Voltage greater than 4.76 volts
- MIL-ON during active fault
- Adaptive-Disabled during active fault

Circuit Description

The TMAP is a combined IAT (Intake Air Temperature) and MAP (Manifold Absolute Pressure) sensor. A temperature sensitive resistor is used in the TMAP is located in the engine's air intake or intake manifold. It is used to monitor incoming air temperature, and the output in conjunction with other sensors is used to determine the airflow to the engine. The ECM provides a voltage divider circuit so that when the air is cool, the signal reads higher voltage, and lower when warm. This fault will set if the signal voltage is greater than 4.76 volts for 1 second or longer. The ECM will use a default value for the IAT sensor in the event of this fault.

DTC 113-IAT Voltage High

Step	Action	Value(s)	Yes	No
1	Did you perform the On-Board (OBD) System Check?	-	Go to Step (2)	Go to OBD System Check Section
2	<ul style="list-style-type: none"> • Key ON • DST (Diagnostic Scan Tool) connected in System Data Mode Does DST display IAT voltage of 4.76 or greater?		Go to Step (3)	Intermittent problem Go to Intermittent section
3	<ul style="list-style-type: none"> • Key OFF • Disconnect the TMAP sensor connector C006 and jump pins D and C together • Key ON Does the DST display IAT voltage of 0.1 volts or less?		Go to Step (9)	Go to Step (4)
4	<ul style="list-style-type: none"> • Key OFF • Jump TMAP sensor connector signal pin C to engine ground • Key ON Does DST display IAT voltage of 0.1 volts or less?		Go to Step (7)	Go to Step (6)
5	<ul style="list-style-type: none"> • Replace TMAP sensor. Is the replacement complete?		Go to Step (11)	-
6	<ul style="list-style-type: none"> • Key OFF • Disconnect the ECM wire harness connector C001. • Check for continuity between TMAP sensor connector signal pin C and ECM IAT signal pin 24 Do you have continuity between them?	—	Go to Step (10)	Repair the circuit as necessary. Refer to Wiring Repairs in Engine Electrical.
7	<ul style="list-style-type: none"> • Check for continuity between TMAP sensor connector ground circuit pin D and ECM sensor ground circuit pin 3 Do you have continuity between them?	—	Go to Step (10)	Repair the circuit as necessary. Refer to Wiring Repairs in Engine Electrical.

Step	Action	Value(s)	Yes	No
8	<ul style="list-style-type: none"> Replace the ECM. Is the replacement complete?	–	Go to Step (11)	–
9	<ul style="list-style-type: none"> Re-check wire harness and TMAP sensor connector for damage corrosion or contamination Any problems found?		Repair the circuit as necessary. Refer to Wiring Repairs in Engine Electrical	Go to Step (5)
10	<ul style="list-style-type: none"> Re-check wire harness and TMAP sensor connectors for damage corrosion or contamination Any problems found?		Repair the circuit as necessary. Refer to Wiring Repairs in Engine Electrical	Go to Step (8)
11	<ul style="list-style-type: none"> Remove all test equipment except the DST. Connect any disconnected components, fuses, etc. Using the DST clear DTC information from the ECM. Turn the ignition OFF and wait 30 seconds. Start the engine and operate the vehicle to full operating temperature Observe the MIL Observe engine performance and drivability After operating the engine within the test parameters of DTC-113 check for any stored codes. Does the engine operate normally with no stored codes?		System OK	Go to OBD System Check

DTC 116-ECT Higher Than Expected 1 (SPN 110:FMI 15)

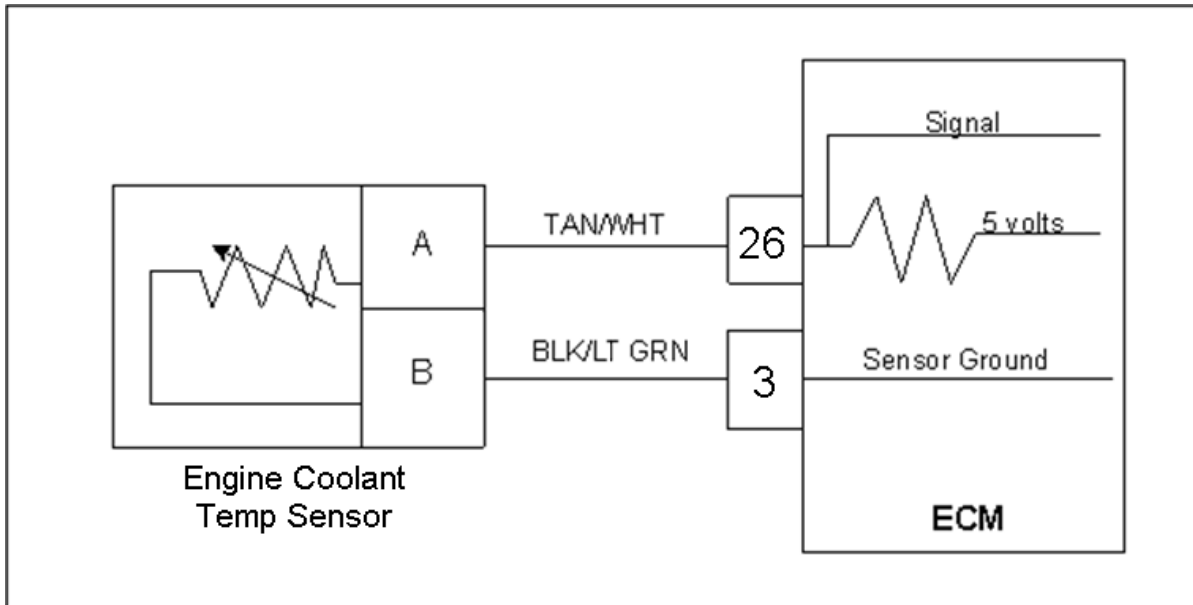

Conditions for Setting the DTC

- Engine Coolant Temperature
- Check Condition-Engine Running
- Fault Condition-Engine Coolant Temperature reading or estimate greater than 220 degrees F. for greater than 10 seconds
- MIL-On
- Power derate (level 2)
- Adaptive-Disabled during active fault

Circuit Description

The ECT (Engine Coolant Temperature) sensor is a temperature sensitive resistor located in the engine coolant sensor that is located in the coolant passage. The ECT is used for engine airflow calculation, fuel enrichment, and ignition timing control and to enable certain other temperature dependent operations. This code set is designed to help prevent engine damage from overheating. The ECM provides a voltage divider circuit so when the sensor reading is cool the sensor reads higher voltage, and lower when warm. This fault will set when the coolant exceeds 220 degrees F. for more than 10 seconds. Power derate level 2 will be enforced during this fault.

DTC 116-ECT Higher Than Expected 1

STEP	Action	Value(s)	Yes
1	Did you perform the On-Board (OBD) System Check?	-	Go to Step (2)
2	<ul style="list-style-type: none"> • Key ON • DST (Diagnostic Scan Tool) connected in system data mode <p>Warm engine to normal operating temperature, then run the engine above 1200 rpm for at least 60 seconds</p> <p>Does the DST display ECT temperature of 236 degrees F or greater?</p>		Go to Step (3)
3	<p>Verify with a temperature gauge that the engine coolant is over 220 degrees F.</p> <p>Does the temperature gauge indicated 220 degrees F. or greater?</p>		Repair cooling system.
4	Verify ECT Circuit function. Follow diagnostic test procedure for DTC 217 (ECT Higher than expected 2)		-

DTC 117-ECT/CHT Low Voltage (SPN 110:FMI 4)

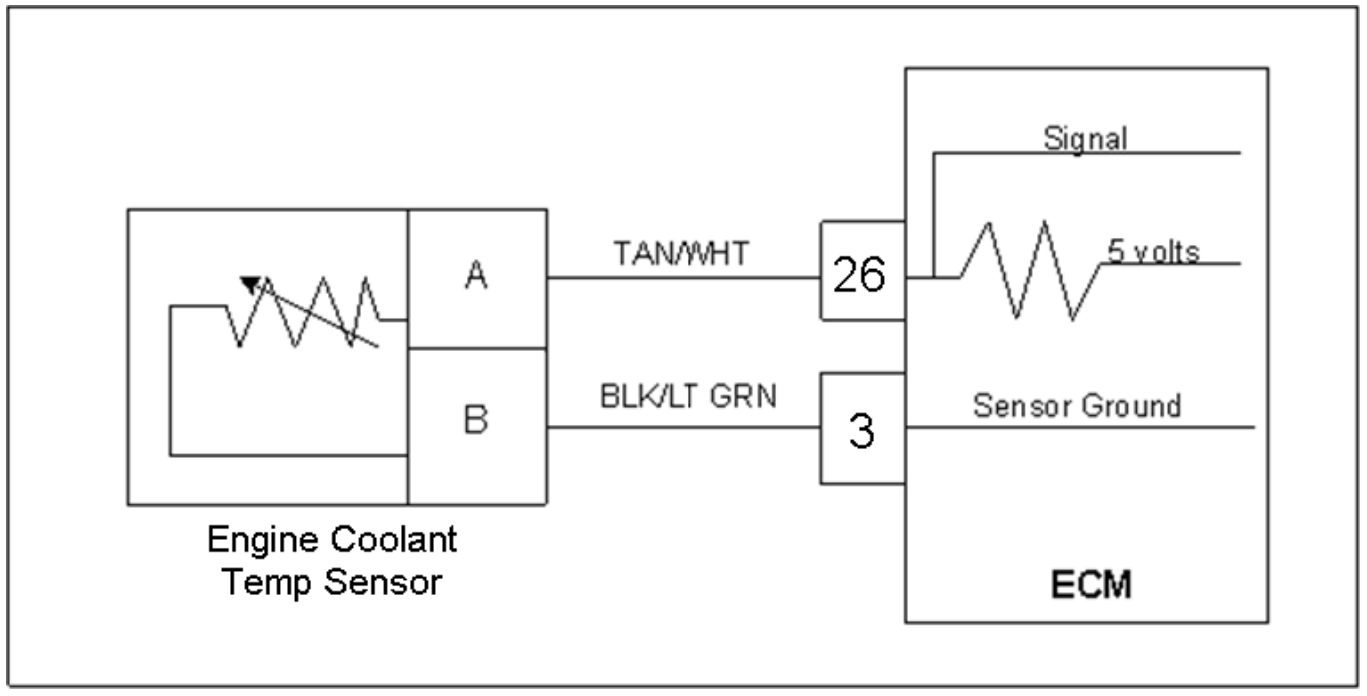

Conditions for Setting the DTC

- Engine Coolant Temperature
- Check Condition-Engine Running
- Fault Condition-ECT sensor voltage less than 0.050
- MIL-ON during active fault
- Adaptive-Disabled during active fault

Circuit Description

The ECT (Engine Coolant Temperature) sensor is a temperature sensitive resistor located in the engine coolant passage. It is used for the engine airflow calculation, cold fuel enrichment and to enable other temperature dependent features. The ECM provides a voltage divider circuit so that when the coolant is cool, the signal reads higher voltage, and lower when warm (see table). This fault will set if the signal voltage is less than 0.050 volts for any period longer than 1 second. The ECM will use a default value for the ECT sensor in the event of this fault.

DTC 117-ECT/CHT Voltage Low

Step	Action	Value(s)	Yes	No
1	Did you perform the On-Board (OBD) System Check?	—	Go to Step (2)	Go to OBD System Check Section
2	<ul style="list-style-type: none"> • Key ON • DST (Diagnostic Scan Tool) connected in System Data Mode Does DST display ECT voltage of 0.050 or less?		Go to Step (3)	Intermittent problem Go to Intermittent section
3	<ul style="list-style-type: none"> • Key OFF • Disconnect the ECT wire harness connector C007 • Key ON Does the DST display ECT voltage of 4.90 volts or greater?		Go to Step (4)	Go to Step (5)
4	<ul style="list-style-type: none"> • Replace ECT sensor. Is the replacement complete?		Go to Step (8)	—
5	<ul style="list-style-type: none"> • Key OFF • Disconnect ECM wire harness connector C001 • Check for continuity between ECT sensor connector signal pin A and ECT sensor ground pin B Do you have continuity between them?	—	Repair the circuit as necessary. Refer to Wiring Repairs in Engine Electrical.	Go to Step (6)
6	<ul style="list-style-type: none"> • Check for continuity between ECT sensor connector signal circuit pin A and engine ground. Do you have continuity?	—	Repair the circuit as necessary. Refer to Wiring Repairs in Engine Electrical.	Go to Step (7)

Step	Action	Value(s)	Yes	No
7	<ul style="list-style-type: none"> • Replace ECM. Refer to ECM replacement in the Engine Controls Section. Is the replacement complete?	–	Go to Step (8)	–
8	<ul style="list-style-type: none"> • Remove all test equipment except the DST. • Connect any disconnected components, fuses, etc. • Using the DST clear DTC information from the ECM. • Turn the ignition OFF and wait 30 seconds. • Start the engine and operate the vehicle to full operating temperature • Observe the MIL • Observe engine performance and drivability • After operating the engine within the test parameters of DTC-117 check for any stored codes. Does the engine operate normally with no stored codes?		System OK	Go to OBD System Check

DTC 118-ECT/CHT High Voltage (SPN 110:FMI 3)

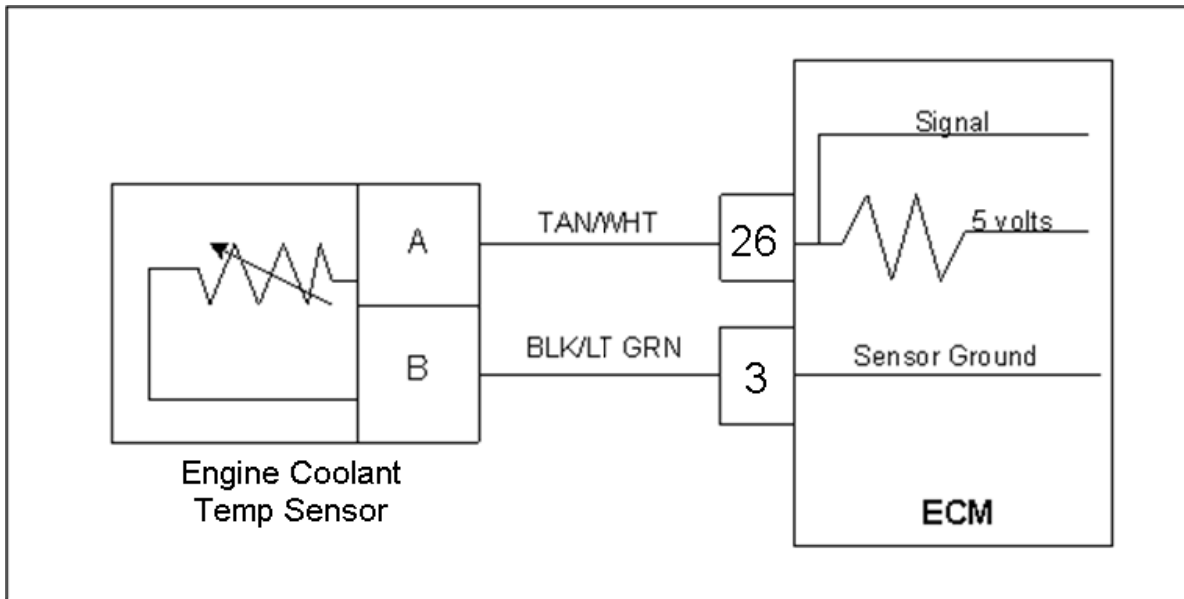

Conditions for Setting the DTC

- Engine Coolant Temperature
- Check Condition-Engine Running
- Fault Condition-ECT sensor voltage exceeds 4.950 volts
- MIL-ON during active fault
- Adaptive-Disabled

Circuit Description

The ECT (Engine Coolant Temperature) sensor is a temperature sensitive resistor located in the engine coolant passage. It is used for the engine airflow calculation, cold fuel enrichment and to enable other temperature dependent features. The ECM provides a voltage divider circuit so that when the coolant is cool, the signal reads higher voltage, and lower when warm (see table). This fault will set if the signal voltage is greater than 4.950 volts anytime the engine is running. The ECM will use a default value for the ECT sensor in the event of this fault.

DTC 118-ECT/CHT Voltage High

Step	Action	Value(s)	Yes	No
1	Did you perform the On-Board (OBD) System Check?	-	Go to Step (2)	Go to OBD System Check Section
2	<ul style="list-style-type: none"> • Key ON • DST (Diagnostic Scan Tool) connected in System Data Mode Does DST display ECT voltage of 4.95 or greater?		Go to Step (3)	Intermittent problem Go to Intermittent section
3	<ul style="list-style-type: none"> • Key OFF • Disconnect the ECT sensor connector C007 and Jump terminals A and B together • Key ON Does the DST display ECT voltage of 0.05 volts or less?		Go to Step (4)	Go to Step (8)
4	<ul style="list-style-type: none"> • Using a DVOM check the resistance between the two terminals of the ECT sensor and compare the resistance reading to the chart Is the resistance value correct?	See resistance chart vs. temperature in the DTC 118 circuit description	Go to Step (6)	Go to Step (5)
5	<ul style="list-style-type: none"> • Replace ECT sensor Is the replacement complete?		Go to Step (14)	-
6	<ul style="list-style-type: none"> • Inspect the ECT wire harness connector terminals A and B for damage, corrosion or contamination Did you find a problem?		Repair the circuit as necessary. Refer to Wiring Repairs in Engine Electrical.	Go to Step (7)
7	<ul style="list-style-type: none"> • Key OFF • Disconnect ECM wire harness connector C001 • Inspect ECM connector pins 26 and 3 for damage corrosion or contamination Did you find a problem?		Repair the circuit as necessary. Refer to Wiring Repairs in Engine Electrical.	Intermittent problem Go to Intermittent section

Step	Action	Value(s)	Yes	No
8	<ul style="list-style-type: none"> Jump the ECT signal pin A at the ECT connector to engine ground Does DST display ECT voltage of 0.05 or less?		Go to Step (9)	Go to Step (12)
9	<ul style="list-style-type: none"> Key OFF Disconnect ECM wire harness connector Using a DVOM check for continuity between ECT sensor ground pin B and ECM connect- or pin 3 Do you have continuity between them?		Go to Step (10)	Repair the circuit as necessary. Refer to Wiring Repairs in Engine Electrical.
10	<ul style="list-style-type: none"> Inspect ECM connector pins 26 and 3 for damage, corrosion or contamination Did you find a problem?		Repair the circuit as necessary. Refer to Wiring Repairs in Engine Electrical.	Go to Step (11)
11	<ul style="list-style-type: none"> Replace ECM Is the replacement complete?		Go to Step (14)	-
12	<ul style="list-style-type: none"> Key OFF Disconnect ECM wire harness connector Using a DVOM check for continuity between ECT connector signal pin A and ECM connector terminal 26 Do you have continuity between them?		Go to Step (13)	Repair the circuit as necessary. Refer to Wiring Repairs in Engine Electrical.
13	<ul style="list-style-type: none"> Inspect ECM connector pins 26 and 3 for damage, corrosion or contamination Did you find a problem?		Repair the circuit as necessary. Refer to Wiring Repairs in Engine Electrical.	Go to Step (11)
14	<ul style="list-style-type: none"> Remove all test equipment except the DST. Connect any disconnected components, fuses, etc. Using the DST clear DTC information from the ECM. Turn the ignition OFF and wait 30 seconds. Start the engine and operate the vehicle to full operating temperature Observe the MIL Observe engine performance and drivability After operating the engine within the test parameters of DTC-118 check for any stored codes. Does the engine operate normally with no stored codes?		System OK	Go to OBD System Check

DTC 121-TPS 1 Lower Than TPS 2 (SPN 51:FMI 1)

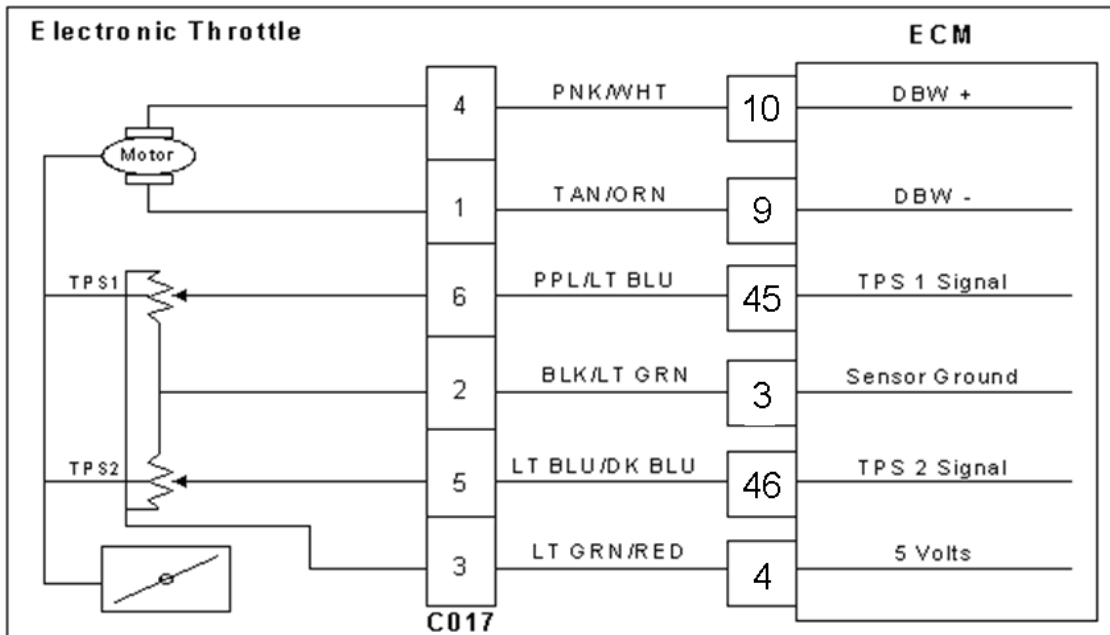

Conditions for Setting the DTC

- Throttle Position Sensor 1 & 2
- Check Condition-Key ON
- Fault Condition-TPS 1 20% lower than TPS 2
- MIL-ON for remainder of key on cycle
- Engine shutdown

Circuit description

Dual throttle Position Sensors are used within the throttle that use variable resistors to determine signal voltage based on throttle plate position. TPS 1 will read low voltage when closed and TPS 2 will read high voltage when closed. The TPS 1 and TPS 2 percentages are calculated from these voltages. Although the voltages are different, the calculated values for the throttle position percentages should be very close to the same. The TPS values are used by the ECM to determine if the throttle is opening as commanded. This fault will set if TPS 1 is 20% (or more) lower than TPS 2. At this point the throttle is considered to be out of specification, or there is a problem with the TPS signal circuit. The MIL command is on and the engine will shutdown.

DTC 121 TPS 1 Lower Than TPS 2

Step	Action	Value(s)	Yes	No
1	Did you perform the On-Board (OBD) System Check?	-	Go to Step (2)	Go to OBD System Check Section
2	<ul style="list-style-type: none"> • Key ON, Engine OFF • DST (Diagnostic Scan Tool) connected in System Data Mode Does the DST display more than a 20% difference between TPS 1 and TPS 2 voltage?		Go to Step (3)	Intermittent problem Go to Intermittent section
3	<ul style="list-style-type: none"> • Key OFF • Disconnect electronic throttle connector C017 • Key ON • Change DST mode to DBW (drive by wire) test mode Is the voltage for TPS 1 less than 0.1 volts?		Go to Step (5)	Go to Step (4)
4	<ul style="list-style-type: none"> • Key OFF • Disconnect ECM wiring harness connector C001 • Key ON • Using a DVOM check for voltage between ECM connector TPS 1 signal pin 5 and engine ground Do you have voltage?		Repair the TPS 1 circuit shorted to voltage as necessary. Refer to Wiring Repairs in Engine Electrical.	Go to Step (9)
5	<ul style="list-style-type: none"> • Jump TPS 1 signal pin 6 to the 5 volt reference pin 3 at connector C017 Does DST display TPS 1 voltage over 4.90 volts		Go to Step (6)	Go to Step (8)
6	<ul style="list-style-type: none"> • Inspect wire terminals at throttle connector for damage corrosion or contamination Any problems found?		Repair the circuit as necessary. Refer to Wiring Repairs in Engine Electrical.	Go to Step (7)
7	<ul style="list-style-type: none"> • Replace the electronic Throttle Is the replacement complete?		Go to Step (12)	-
8	<ul style="list-style-type: none"> • Key OFF • Disconnect ECM wire harness connector C001 • Using a DVOM check for continuity between throttle connector TPS 1 signal pin 6 and ECM connector TPS 1 signal pin 45 Do you have continuity between them?		Go to Step (9)	Repair the open circuit as necessary. Refer to Wiring Repairs in Engine Electrical.

Step	Action	Value(s)	Yes	No
9	<ul style="list-style-type: none"> Using a DVOM check for continuity between throttle connector signal ground pin 2 and ECM connector signal ground pin 3 Do you have continuity between them?		Go to Step (10)	Repair the open circuit as necessary. Refer to Wiring Repairs in Engine Electrical.
10	<ul style="list-style-type: none"> Inspect ECM connector terminals for damage corrosion or contamination. Any problems found?		Repair the circuit as necessary. Refer to Wiring Repairs in Engine Electrical	Go to Step (11)
11	<ul style="list-style-type: none"> Replace ECM Is the replacement complete?		Go to Step (12)	-
12	<ul style="list-style-type: none"> Remove all test equipment except the DST. Connect any disconnected components, fuses, etc. Using the DST clear DTC information from the ECM. Turn the ignition OFF and wait 30 seconds. Start the engine and operate the vehicle to full operating temperature Observe the MIL Observe engine performance and drivability After operating the engine within the test parameters of DTC-121 check for any stored codes. Does the engine operate normally with no stored codes?		System OK	Go to OBD System Check

DTC 122-TPS 1 Low Voltage (SPN 51:FMI 4)

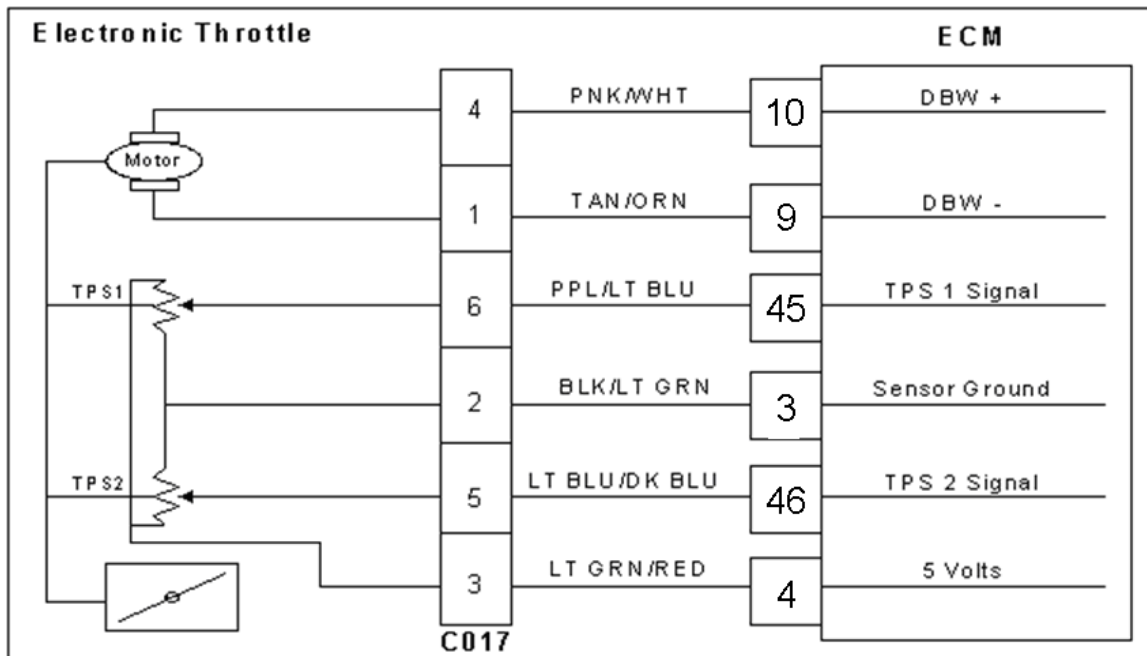

Conditions for Setting the DTC

- Throttle Position Sensor 1
- Check Condition-Cranking or Running
- Fault Condition-TPS sensor less than 0.200 volts
- MIL-ON during active fault
- Engine shutdown

Circuit Description

Dual throttle Position Sensors are used within the throttle that use variable resistors to determine signal voltage based on throttle plate position. TPS1 will read lower voltage when closed and TPS2 will read higher voltage when closed. The TPS1 and TPS2 percentages are calculated from these voltages. Although the voltages are different, the calculated values for the throttle position percentages should be very close to the same. The TPS values are used by the ECM to determine if the throttle is opening as commanded. The TPS is not serviceable and in the event of a failure the electronic throttle assembly must be replaced. This fault will set if the TPS 1 voltage is less than 0.200 volts. The MIL command is ON and the engine will shut down.

DTC 122 TPS 1 Signal Voltage Low

Step	Action	Value(s)	Yes	No
1	Did you perform the On-Board (OBD) System Check?	-	Go to Step (2)	Go to OBD System Check Section
2	<ul style="list-style-type: none"> • Key ON, Engine OFF • DST (Diagnostic Scan Tool) connected in DBW (Drive by Wire) throttle test mode Does the DST display TPS 1 voltage of 0.200 volts or less with the throttle closed?		Go to Step (4)	Go to Step (3)
3	<ul style="list-style-type: none"> • Slowly depress Foot Pedal while observing TPS 1 voltage Does TPS 1 voltage ever fall below 0.200 volts?		Go to Step (4)	Intermittent problem Go to Intermittent section
4	<ul style="list-style-type: none"> • Key OFF • Disconnect the electronic throttle connector C017 • Jump the 5 volt reference circuit pin 3 and TPS 1 signal circuit pin 6 together at the throttle connector • Key ON Does DST display TPS 1 voltage of 4.0 volts or greater?		Go to Step (7)	Go to Step (5)
5	<ul style="list-style-type: none"> • Key OFF • Disconnect ECM wire harness connector C001 • Using a DVOM check continuity between the electronic throttle connector signal pin 6 and ECM connector TPS 1 signal pin 45 Do have continuity between them?		Go to Step (6)	Repair the circuit as necessary. Refer to Wiring Repairs in Engine Electrical.
6	<ul style="list-style-type: none"> • Replace ECM Is the replacement complete?		Go to Step (9)	-
7	<ul style="list-style-type: none"> • Inspect the throttle wire harness connector terminals for damage, corrosion or contamination Did you find a problem?		Repair the circuit as necessary. Refer to Wiring Repairs in Engine Electrical.	Go to Step (8)
8	<ul style="list-style-type: none"> • Replace the electronic throttle Is the replacement complete?		Go to Step (9)	-

Step	Action	Value(s)	Yes	No
9	<ul style="list-style-type: none"> • Remove all test equipment except the DST. • Connect any disconnected components, fuses, etc. • Using the DST clear DTC information from the ECM. • Turn the ignition OFF and wait 30 seconds. • Start the engine and operate the vehicle to full operating temperature • Observe the MIL • Observe engine performance and drivability • After operating the engine within the test parameters of DTC-122 check for any stored codes. <p>Does the engine operate normally with no stored codes?</p>		System OK	Go to OBD System Check

DTC 123-TPS 1 High Voltage (SPN 51:FMI 3)

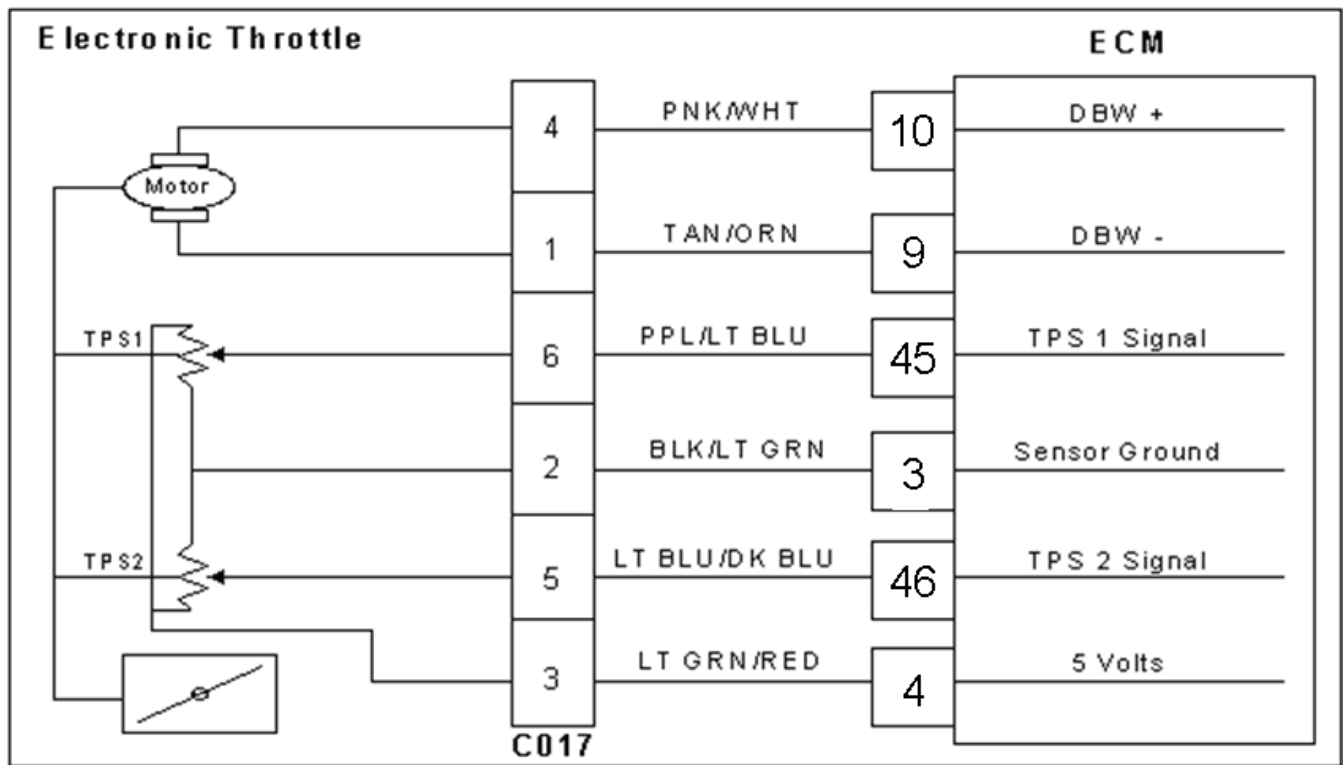

Conditions for Setting the DTC

- Throttle Position Sensor 1
- Check Condition-Cranking or Running
- Fault Condition-TPS sensor voltage exceeds 4.800 volts
- MIL-ON during active fault
- Engine shutdown

Circuit Description

Dual throttle Position Sensors are used within the throttle that use variable resistors to determine signal voltage based on throttle plate position. TPS1 will read lower voltage when closed and TPS2 will read higher voltage when closed. The TPS1 and TPS2 percentages are calculated from these voltages. Although the voltages are different, the calculated values for the throttle position percentages should be very close to the same. The TPS values are used by the ECM to determine if the throttle is opening as commanded. The TPS is not serviceable and in the event of a failure the electronic throttle assembly must be replaced. This fault will set if the TPS 1 voltage exceeds 4.800 volts. The MIL command is ON and the engine will shut down.

DTC 123 TPS 1 Signal Voltage High

Step	Action	Value(s)	Yes	No
1	Did you perform the On-Board (OBD) System Check?	-	Go to Step (2)	Go to OBD System Check Section
2	<ul style="list-style-type: none"> • Key ON, Engine OFF • DST (Diagnostic Scan Tool) connected Does the DST display TPS 1 voltage of 4.800 volts or greater with the throttle closed?		Go to Step (4)	Go to Step (3)
3	<ul style="list-style-type: none"> • Slowly depress Foot Pedal while observing TPS 1 voltage Does TPS 1 voltage ever exceed 4.800 volts?		Go to Step (4)	Intermittent problem Go to Intermittent section
4	<ul style="list-style-type: none"> • Key OFF • Disconnect electronic throttle connector • Key ON Does DST display TPS 1 voltage less than 0.2 volts?		Go to Step (7)	Go to Step (5)
5	<ul style="list-style-type: none"> • Key OFF • Disconnect ECM wire harness connector C001 • Key ON • Using a DVOM check for voltage between TPS 1 signal at the ECM connector pin 45 and engine ground Do you have voltage?		Repair the circuit as necessary. Refer to Wiring Repairs in Engine Electrical.	Go to Step (6)
6	<ul style="list-style-type: none"> • Replace ECM Is the replacement complete?		Go to Step (11)	-
7	<ul style="list-style-type: none"> • Back probe sensor ground circuit at the ECM side of the wire harness pin 3 with a test light connected to battery voltage Does the test light come on?		Go to Step (8)	Go to Step (10)
8	<ul style="list-style-type: none"> • Inspect the electronic throttle connector terminals for damage, corrosion or contamination Did you find a problem?		Repair the circuit as necessary. Refer to Wiring Repairs in Engine Electrical.	Go to Step (9)
9	<ul style="list-style-type: none"> • Replace the electronic throttle Is the replacement complete?		Go to Step (11)	-
10	<ul style="list-style-type: none"> • Key OFF • Disconnect ECM connector C001 • Using a DVOM check for continuity between the electronic throttle connector sensor ground pin 2 and ECM connector TPS 1 sensor ground pin 3 Do have continuity between them?		Go to Step (6)	Repair the circuit as necessary. Refer to Wiring Repairs in Engine Electrical.

Step	Action	Value(s)	Yes	No
11	<ul style="list-style-type: none"> • Remove all test equipment except the DST. • Connect any disconnected components, fuses, etc. • Using the DST clear DTC information from the ECM. • Turn the ignition OFF and wait 30 seconds. • Start the engine and operate the vehicle to full operating temperature • Observe the MIL • Observe engine performance and drivability • After operating the engine within the test parameters of DTC-123 check for any stored codes. <p>Does the engine operate normally with no stored codes?</p>		System OK	Go to OBD System Check

DTC 127-IAT Higher Than Expected 2 (SPN 105:FMI 0)

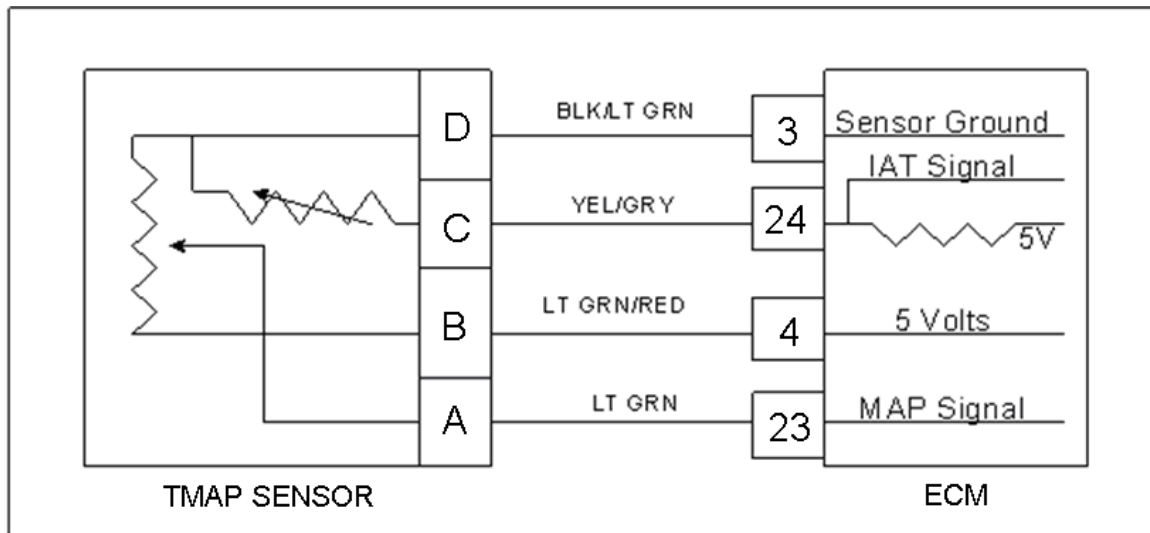

Conditions for Setting the DTC

- Intake Air Temperature
- Check Condition-Engine Running
- Fault Condition-Intake Air Temperature greater than 210 degrees F. with engine speed greater than 600 rpm
- Fault condition must be active for longer than 1 second
- MIL-ON for active fault
- Engine will shutdown with an active fault

Circuit Description

The TMAP is a combined IAT (Intake Air Temperature) and MAP (Manifold Absolute Pressure) sensor. A temperature sensitive resistor is used in the TMAP located in the intake manifold of the engine. It is used to monitor incoming air temperature, and the output in conjunction with other sensors is used to determine the airflow to the engine. The ECM provides a voltage divider circuit so that when the air is cool, the signal reads a higher voltage, and lower when warm. This fault will set if the intake air temperature is greater than 210 degrees F. with engine speed greater than 600 rpm. The MIL light command is on during this active fault and the engine will shutdown to prevent damage.

DTC 127-IAT Higher Than Expected 2

Diagnostic Aid

- This fault will set when inlet air is much hotter than normal. The most common cause of high inlet air temperature is a problem with the inlet air system. Ensure that the air inlet is not obstructed, modified or damaged.
- Inspect the air inlet system for cracks or breaks that may allow unwanted under hood air in to the air inlet system
- If none of the above can be found, follow the diagnostic steps for DTC 112-IAT Low Voltage.

DTC 129-BP Low Pressure (SPN 108: FMI 1)

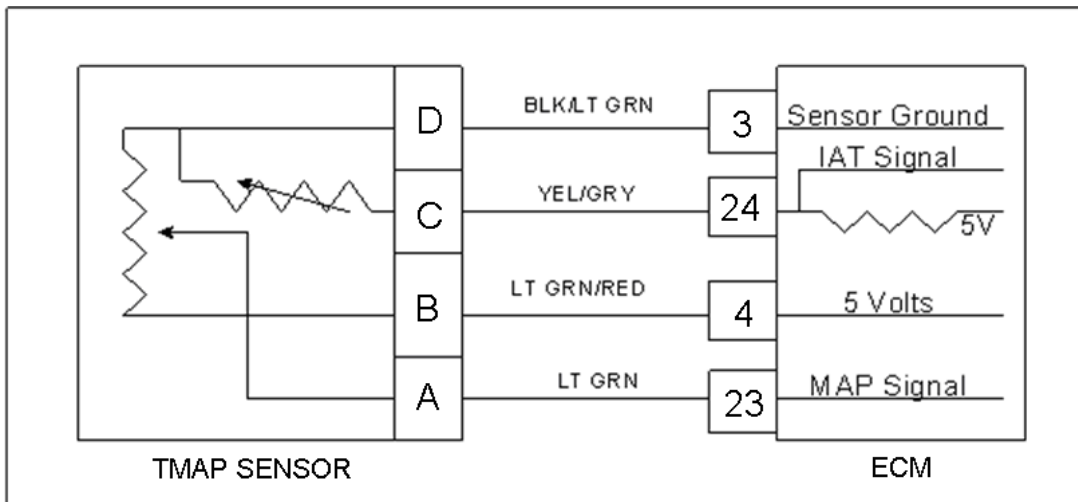

Conditions for Setting the DTC

- Barometric Pressure
- Check Condition-Key ON
- Fault Condition-BP less than 8.30 psia
- MIL-ON for active fault
- Adaptive-Disabled

Circuit Description

The BP (Barometric Pressure) is estimated from the TMAP sensor. The barometric pressure value is used for fuel and airflow calculations. This fault sets in the event the BP value is out of the normal range.

DTC 129-BP Low Pressure

Step	Action	Value(s)	Yes	No
1	Did you perform the On-Board (OBD) System Check?	-	Go to Step (2)	Go to OBD System Check Section
2	<ul style="list-style-type: none"> • Key ON. • DST (Diagnostic Scan Tool) connected in System Data Mode Does DST display BP pressure of 8.30 psia or less?		Go to Step (3)	Intermittent problem. Go to Intermittent section
3	<ul style="list-style-type: none"> • Key OFF • Disconnect the TMAP sensor connector • Jump the 5 volt reference pin B and MAP signal pin A together • Key ON Does the DST display BP pressure of 16.00 psia or greater?		Go to Step (4)	Go to Step (8)
4	<ul style="list-style-type: none"> • Inspect TMAP connector and wire harness connector terminals for corrosion, contamination or mechanical damage Any problems found?		Repair the circuit as necessary. Refer to Wiring Repairs in Engine Electrical.	Go to Step (5)
5	<ul style="list-style-type: none"> • Key OFF • Disconnect ECM connector C001 • Check for continuity between TMAP sensor connector pin A and ECM connector pin 23 Do you have continuity between them?		Go to Step (6)	Repair the circuit as necessary. Refer to Wiring Repairs in Engine Electrical.
6	<ul style="list-style-type: none"> • Check for continuity between TMAP sensor connector 5 volt supply pin B and ECM connector pin 4 Do you have continuity between them?		Go to Step (7)	Repair the circuit as necessary. Refer to Wiring Repairs in Engine Electrical.
7	<ul style="list-style-type: none"> • Check for continuity between TMAP sensor connector ground pin D and ECM connector pin 3 Do you have continuity between them?		Go to Step (17)	Repair the circuit as necessary. Refer to Wiring Repairs in Engine Electrical.

Step	Action	Value(s)	Yes	No
8	<ul style="list-style-type: none"> Remove the Jumper that was installed during step 3 Probe TMAP connector signal circuit pin A with a test light connected to battery voltage Does the DST display BP pressure of 16.00 psia or greater?		Go to Step (9)	Go to Step (13)
9	<ul style="list-style-type: none"> Key OFF Disconnect ECM connector C001 Check for continuity between TMAP sensor connector pin B and ECM connector pin 4 Do you have continuity between them?		Go to Step (10)	Repair the circuit as necessary. Refer to Wiring Repairs in Engine Electrical.
10	<ul style="list-style-type: none"> Check for continuity between TMAP sensor connector 5 volt reference pin B and engine ground Do you have continuity?		Repair the open ground circuit as necessary. Refer to Wiring Repairs in Engine Electrical.	Go to Step (11)
11	<ul style="list-style-type: none"> Inspect TMAP and ECM connector pins for corrosion, contamination or mechanical damage Any problems found?		Repair the circuit as necessary. Refer to Wiring Repairs in Engine Electrical.	Go to Step (16)
12	<ul style="list-style-type: none"> Replace ECM. Refer to ECM replacement in the Engine Controls Section. Is the replacement complete?		Go to Step(17)	-
13	<ul style="list-style-type: none"> Disconnect ECM connector C001 Check for continuity between TMAP sensor connector pin A and ECM pin 23 Do you have continuity between them?		Go to Step (14)	Repair the circuit as necessary. Refer to Wiring Repairs in Engine Electrical.
14	<ul style="list-style-type: none"> Check for continuity between TMAP sensor connector pin A and engine ground Do you have continuity?		Repair the open ground circuit as necessary. Refer to Wiring Repairs in Engine Electrical.	Go to Step (15)

Step	Action	Value(s)	Yes	No
15	<ul style="list-style-type: none"> Inspect ECM connector and wire harness connector pins for corrosion, contamination or mechanical damage Any problems found?		Repair the circuit as necessary. Refer to Wiring Repairs in Engine Electrical.	Go to Step (16)
16	<ul style="list-style-type: none"> Replace ECM. Refer to ECM replacement in the Engine Controls Section. Is the replacement complete?		Go to Step (18)	-
17	<ul style="list-style-type: none"> Replace TMAP sensor Is the replacement complete?		Go to Step (18)	-
18	<ul style="list-style-type: none"> Remove all test equipment except the DST. Connect any disconnected components, fuses, etc. Using the DST clear DTC information from the ECM. Turn the ignition OFF and wait 30 seconds. Start the engine and operate the vehicle to full operating temperature Observe the MIL Observe engine performance and drivability After operating the engine within the test parameters of DTC-129 check for any stored codes. Does the engine operate normally with no stored codes?		System OK	Go to OBD System Check

DTC 134-EGO 1 Pre Cat Open/Lazy (SPN 724:FMI 10)

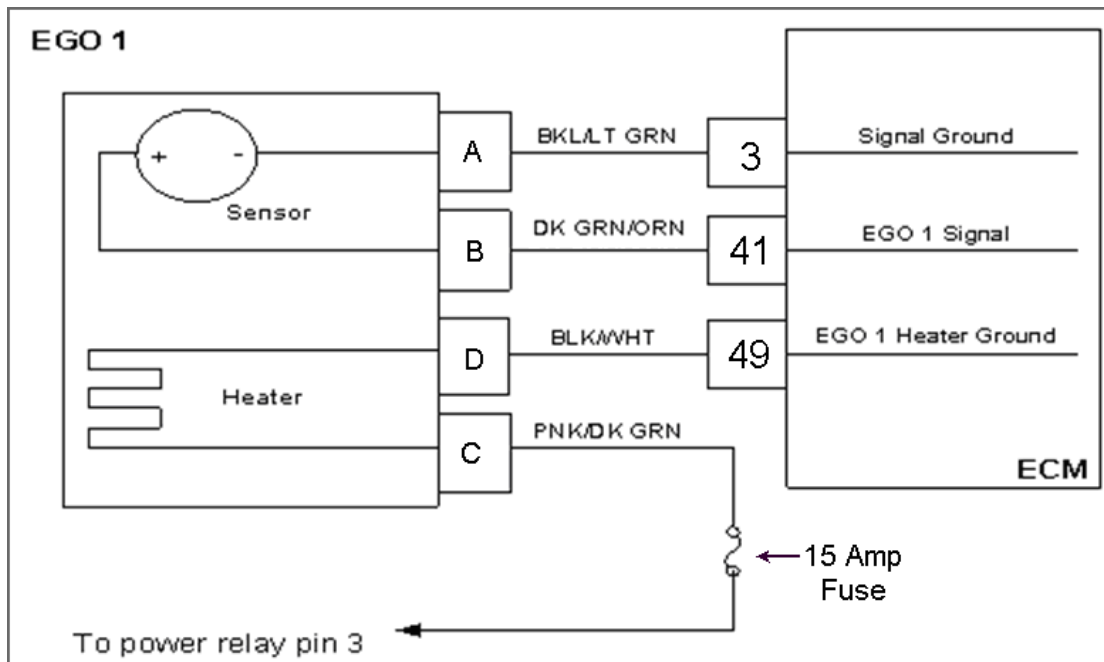

Conditions for Setting the DTC

- Heated Oxygen Sensor
- Check condition- Engine running
- Fault condition-EGO 1 pre catalyst persistently cold for more than 120 seconds
- MIL-ON during active fault
- Adaptive-Disabled during active fault
- Closed Loop-Disabled during active fault

Circuit Description

The EGO 1 sensor is used to determine if the fuel flow to the engine is correct by measuring the oxygen content in the exhaust gas. The ECM uses this information to correct the fuel flow with the Closed Loop multiplier and the Adaptive multiplier. This fault will set if EGO 1 is cold, non-responsive, or inactive for more than 120 seconds.

DTC 134-EGO 1 Open/Inactive

Step	Action	Value(s)	Yes	No
1	Did you perform the On-Board (OBD) System Check?	-	Go to Step (2)	Go to OBD System Check Section
2	<ul style="list-style-type: none"> • Key ON, Engine Running • DST (Diagnostic Scan Tool) connected in System Data Mode • Run engine to full operating temperature and then idle for a minimum of 2 minutes Does DST display EGO 1 voltage fixed between 0.4 and 0.5 volts after at least 2 minutes of idle run time?		Go to Step (3)	Intermittent problem. See Electrical Section Intermittent Electrical Diagnosis
3	<ul style="list-style-type: none"> • Key OFF • Disconnect EGO 1 connector C005 • Key ON • Using a DVOM check for voltage between EGO 1 connector pins C and D (Check must be made within 30 seconds or before power relay shuts down) Do you have voltage?		Go to Step (8)	Go To Step (4)
4	<ul style="list-style-type: none"> • Key OFF • Using a DVOM check for voltage between EGO 1 connector pin C and engine ground • Key ON (Check must be made within 30 seconds or before power relay shuts down) Do you have voltage?	System Voltage	Go to Step (5)	Repair system power relay open circuit
5	<ul style="list-style-type: none"> • Disconnect ECM connector C001 • Using a DVOM check for continuity between EGO 1 connector pin D and ECM connector pin 49 Do you have continuity?		Go to Step (6)	Repair open heater ground circuit
6	<ul style="list-style-type: none"> • Inspect wire harness connector C005 pins B and D and C001 pins 1 and 49 for damage, corrosion or contamination Did You find a problem?		Correct the problem as required see Electrical Section wire harness repair	Go to Step (7)
7	<ul style="list-style-type: none"> • Replace ECM Is the replacement complete?		Go to Step (11)	-

Step	Action	Value(s)	Yes	No
8	<ul style="list-style-type: none"> • Key OFF • Disconnect ECM wire harness connector C001 • Using a DVOM check for continuity between EGO 1 pin B and ECM connector pin 41 Do you have continuity?		Go to Step (9)	Repair open EGO 1 circuit
9	<ul style="list-style-type: none"> • Using a DVOM check for continuity between EGO 1 pin A and ECM connector pin 3 Do you have continuity?		Go to Step (10)	Repair open EGO 1 signal ground
10	<ul style="list-style-type: none"> • Replace EGO 1 sensor Is the replacement complete?		Go to Step (11)	-
11	<ul style="list-style-type: none"> • Remove all test equipment except the DST. • Connect any disconnected components fuses, etc. • Using the DST clear DTC information from the ECM. • Turn the ignition OFF and wait 30 seconds. • Start the engine and operate the vehicle to full operating temperature • Observe the MIL • Observe engine performance and drivability • After operating the engine within the test parameters of DTC-134 check for any stored codes. Does the engine operate normally with no stored codes?		System OK	Go to OBD System Check

DTC 171-Adaptive Learn High Gasoline (SPN 520200:FMI 0)

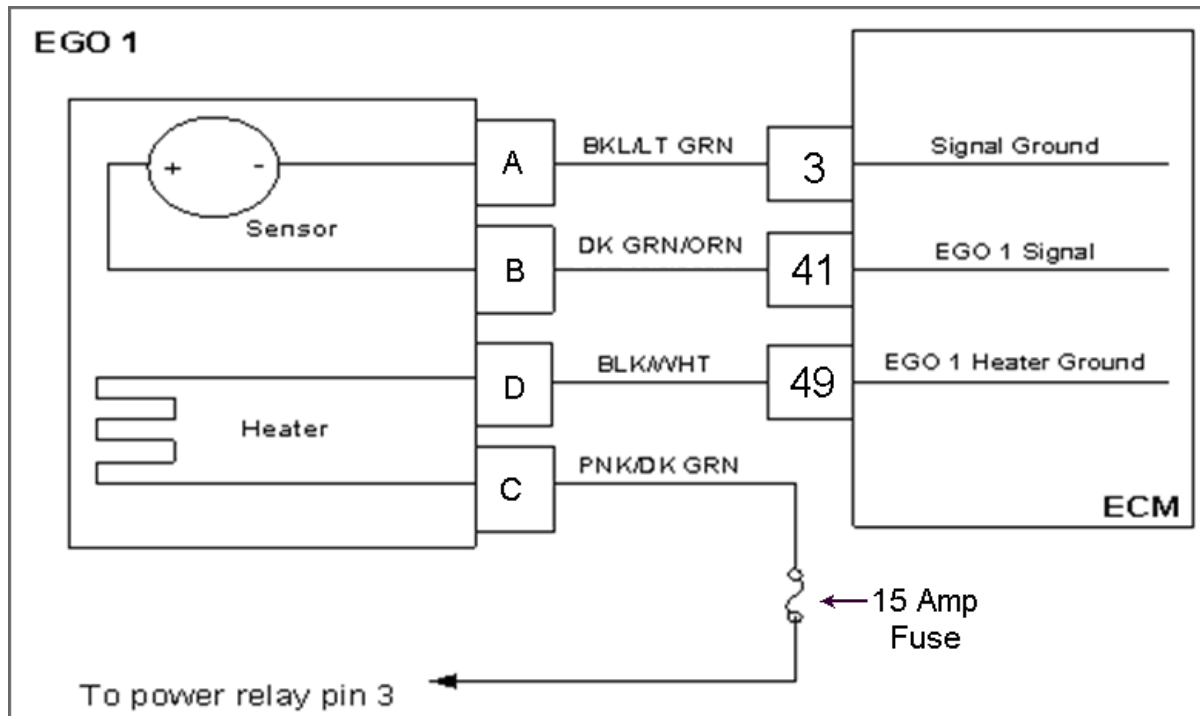

Conditions for Setting the DTC

- Heated Oxygen Sensor
- Check Condition-Engine Running
- Fault Condition-Adaptive multiplier out of range greater than 30%
- MIL-ON

Circuit Description

The EGO 1 sensor is used to determine if the fuel flow to the engine is correct by measuring the oxygen content in the exhaust gas. The ECM uses this information to correct the fuel flow with the Closed Loop multiplier and Adaptive multiplier. This fault will set if the adaptive multiplier exceeds the limits of normal operation. Always run the fuel system diagnostic checks before using the following diagnostic chat.

Diagnostic Aid

Oxygen Sensor Wire Heated Oxygen sensor wires may be mis-routed and contacting the exhaust manifold.

Vacuum Leaks Large vacuum leaks and crankcase leaks can cause a lean exhaust condition at especially at light load.

Fuel Pressure Low fuel pressure, faulty fuel pressure sensor, faulty pump, or contaminated fuel filter can cause fuel the system to run lean

Exhaust Leaks If there is an exhaust leak, outside air can be pulled into the exhaust and past the O2 sensor causing a false lean condition.

Fuel Quality Contaminated or spoiled fuel can cause the fuel system to be lean.

Ground Problem ECM grounds must be clean, tight and in the proper location.

DTC 171-Adaptive Learn High Gasoline

Step	Action	Value(s)	Yes	No
1	<ul style="list-style-type: none"> Perform the On-Board (OBD) System Check? Are any other DTCs present?		Go to Step (3)	Go to Step (2)
2	Visually and physically check the following items: <ul style="list-style-type: none"> The air intake duct for being collapsed or restricted The air filter for being plugged System power fuses are good and in the proper location The EGO 1 sensor installed securely and the wire leads not contacting the exhaust manifold or ignition wires ECM grounds must be clean and tight. Refer to Engine Electrical Power and Ground Distribution Fuel System Diagnostics. Refer to Fuel System Diagnostics Was a repair made?		Go to Step (9)	Go to Step (4)
3	<ul style="list-style-type: none"> Diagnose any other DTC codes before proceeding with this chart. Always repair existing codes starting with the lowest numerical code set first. Have any other DTC codes been detected, diagnosed and repaired?		Go to Step (9)	Go to Step (4)
4	<ul style="list-style-type: none"> Disconnect EGO1 connector C005 Using a DVOM check for voltage between EGO 1 connector pin B and engine ground Key ON (CHECK MUST BE MADE WITHIN 30 SECONDS OR BEFORE POWER RELAY SHUTS DOWN) Do you have voltage?	System voltage	Go to Step (5)	Repair the open EGO power circuit as necessary. Refer to Wiring Repairs in Engine Electrical.
5	<ul style="list-style-type: none"> Key OFF Disconnect EGO 1 sensor wire harness connector C005 Disconnect ECM wire harness connector C001 Key ON Using a high impedance DVOM check for continuity between EGO 1 connector signal pin A and engine ground Do you have continuity?		Repair the shorted circuit as necessary. Refer to Wiring Repairs in Engine Electrical.	Go to Step (6)

Step	Action	Value(s)	Yes	No
6	<ul style="list-style-type: none"> Using a high impedance DVOM check for continuity between EGO 1 connector signal ground pin C and EGO 1 signal pin A Do you have continuity?		Repair the shorted circuit as necessary. Refer to Wiring Repairs in Engine Electrical.	Go to Step (7)
7	<ul style="list-style-type: none"> Using a high impedance DVOM check for continuity between EGO 1 heater ground pin D and ECM pin 49 Do you have continuity?		Go to Step (8)	Repair the open EGO heater ground
8	<ul style="list-style-type: none"> Replace EGO 1 sensor Is the replacement complete?		Go to Step (9)	-
9	<ul style="list-style-type: none"> Remove all test equipment except the DST. Connect any disconnected components, fuses, etc. Using the DST clear DTC information from the ECM. Turn the ignition OFF and wait 30 seconds. Start the engine and operate the vehicle to full operating temperature Observe the MIL Observe engine performance and drivability After operating the engine within the test parameters of DTC-1161 check for any stored codes. Does the engine operate normally with no stored codes?		System OK	Go to OBD System Check

DTC 172-Adaptive Learn Low (Gasoline) (SPN 520200:FMI 1)

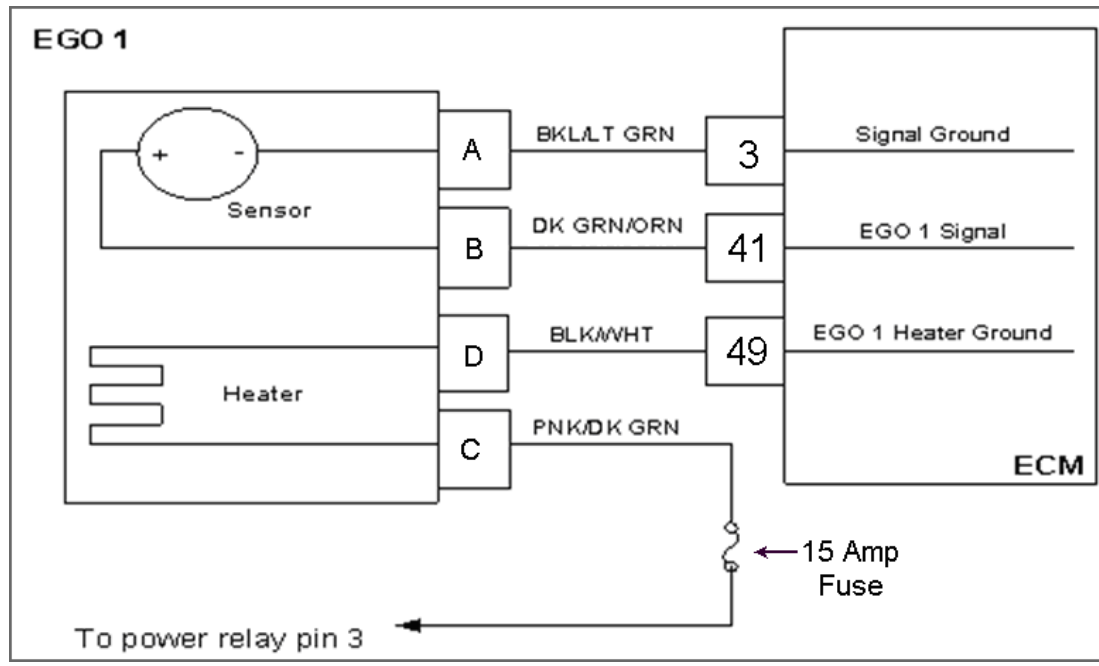

Conditions for Setting the DTC

- Heated Oxygen Sensor
- Check Condition-Engine running
- Fault Condition-Adaptive multiplier out of range greater than -30%
- MIL-ON

Circuit Description

The EGO1 sensor is used to determine if the fuel flow to the engine is correct by measuring the oxygen content in the exhaust gas. The ECM uses this information to correct the fuel flow with the Closed Loop multiplier and Adaptive multiplier. This fault will set if the adaptive multiplier exceeds the limits of normal operation. Always run the fuel system diagnostics before using the following diagnostic chart.

Diagnostic Aid

Fuel System High fuel pressure will cause the system to run rich. Fuel pressure is controlled by the ECM using a ground side driver. If the fuel pump is turned on all the time the fuel pressure will increase. Open or leaking injector will cause a rich condition.

Fuel Quality A drastic variation in fuel quality may cause the fuel system to run rich.

Air Filter A plugged, damaged or modified air filter may cause the system to run rich.

DTC 172-Adaptive Learn Low (Gasoline)

Step	Action	Value(s)	Yes	No
1	<ul style="list-style-type: none"> Perform the On-Board (OBD) System Check? Are any other DTCs present?		Go to Step (3)	Go to Step (2)
2	Visually and physically check the following items: <ul style="list-style-type: none"> The air intake duct for being collapsed or restricted The air filter for being plugged The EGO sensor is installed securely and the wire leads not damaged or contacting the secondary ignition wires ECM grounds for being clean and tight. Fuel system diagnostic checks Was a repair made?		Go to Step (6)	Go to Step (4)
3	<ul style="list-style-type: none"> Diagnose any other DTC codes before proceeding with this chart. Have any other DTC codes been detected, diagnosed and repaired?		Go to Step (6)	Go to Step (4)
4	<ul style="list-style-type: none"> Key OFF Disconnect EGO sensor wire harness connector C005 Disconnect ECM wire harness connector C001 Key ON Using a DVOM check for voltage at EGO 1 connector signal pin A and engine ground Do you have voltage?		Repair the circuit as necessary. Refer to Wiring Repairs in Engine Electrical.	Go to Step (5)
5	<ul style="list-style-type: none"> Replace EGO sensor Is the replacement complete?		Go to Step (6)	-
6	<ul style="list-style-type: none"> Remove all test equipment except the DST. Connect any disconnected components, fuses, etc. Using the DST clear DTC information from the ECM. Turn the ignition OFF and wait 30 seconds. Start the engine and operate the vehicle to full operating temperature Observe the MIL Observe engine performance and drivability After operating the engine within the test parameters of DTC-1162 check for any stored codes. Does the engine operate normally with no stored codes?		System OK	Go to OBD System Check

DTC 217-ECT Higher Than Expected 2 (SPN 110:FMI 0)

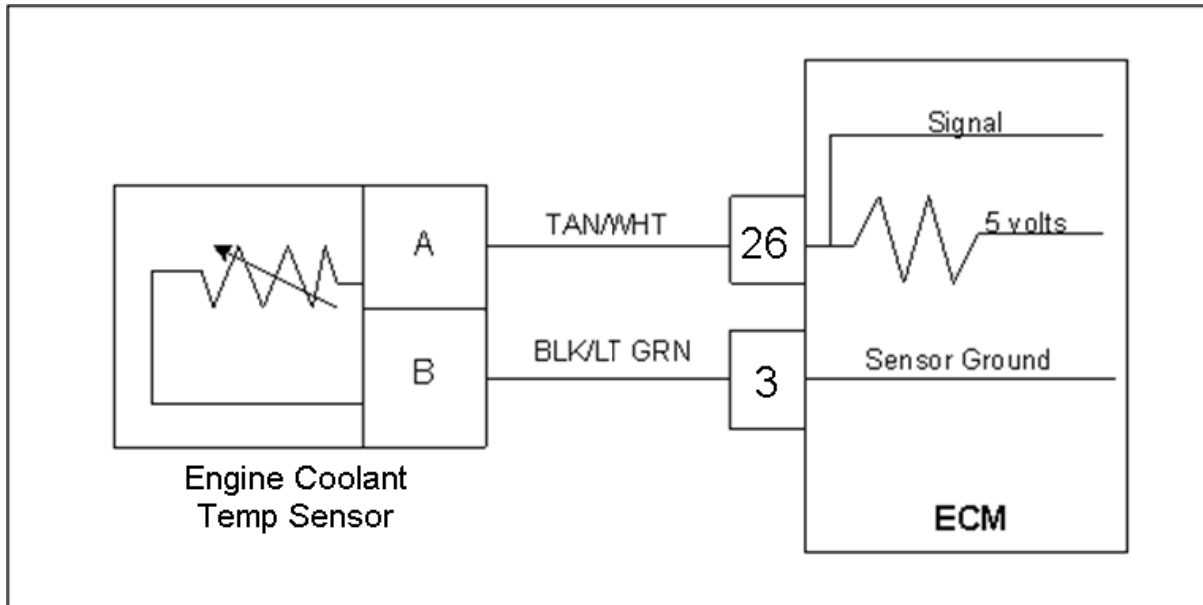

Conditions for Setting the DTC

- Engine Coolant Temperature
- Check Condition-Engine Running
- Fault Condition-Engine Coolant Temperature reading or estimate greater than 230 degrees F. for greater than 1 second while engine is above 600 rpms
- MIL-On
- The engine will shut down during an active fault

Circuit Description

The ECT (Engine Coolant Temperature) sensor is a temperature sensitive resistor located in the engine coolant sensor that is located in the coolant passage. The ECT is used for engine airflow calculation, fuel enrichment, and ignition timing control and to enable certain other temperature dependent operations. This code set is designed to help prevent engine damage from overheating. The ECM provides a voltage divider circuit so when the sensor reading is cool the sensor reads higher voltage, and lower when warm. This fault will set when the coolant exceeds 230 degrees F. for more than 1 second. Engine shutdown will occur if this code occurs.

DTC 217-ECT Higher Than Expected 2

STEP	Action	Value(s)	Yes	No
1	Did you perform the On-Board (OBD) System Check?	-	Go to Step (2)	Go to OBD System Check Section
2	<ul style="list-style-type: none"> • Key ON • DST (Diagnostic Scan Tool) connected in system data mode <p>Warm engine to normal operating temperature, then run the engine above 1200 rpm for at least 60 seconds</p> <p>Does the DST display ECT temperature of 230 degrees F or greater?</p>		Go to Step (3)	Intermittent problem Go to Intermittent section
3	<p>Verify with a temperature gauge that the engine coolant is over 230 degrees F.</p> <p>Does the temperature gauge indicated 230 degrees F. or greater?</p>		Repair cooling system.	Go to step (4)
4	Verify ECT Circuit function.		-	-

DTC 219-Max Govern Speed Override (SPN 515:FMI 15)

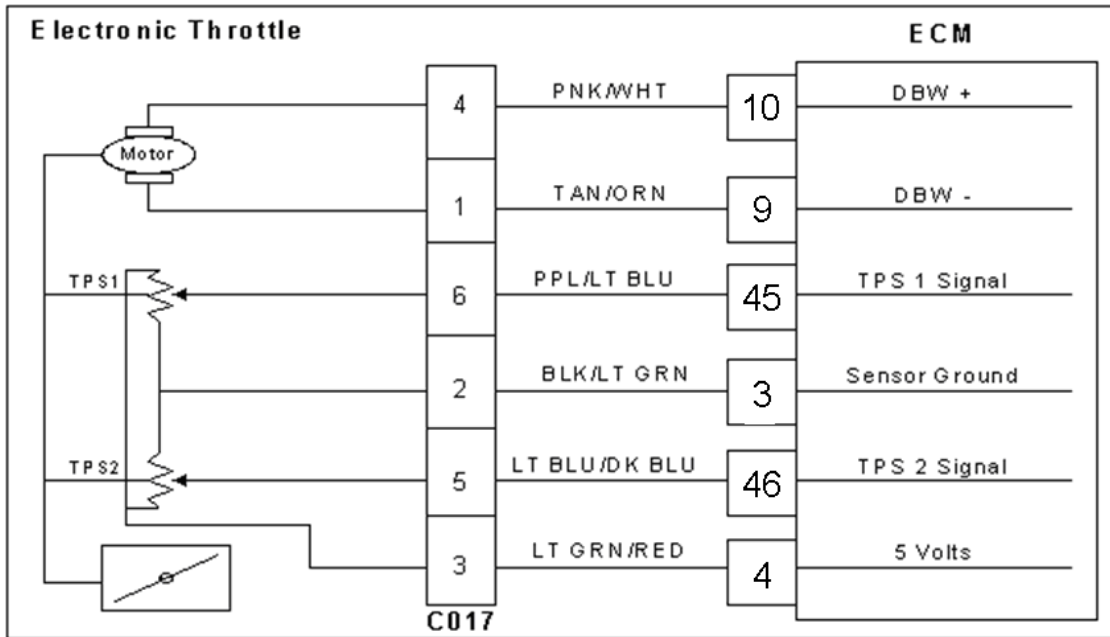

Conditions for Setting the DTC

- Max Govern Speed Override
- Check Condition-Engine Running
- Fault Condition-Engine rpm greater than 3,800
- Fault condition active for 2 or more seconds
- MIL-ON during active fault

Circuit description

This fault will set anytime the engine rpm exceeds 3,800 for longer than 2 seconds. The MIL command is ON during this active fault

Diagnostic Aid

Check for other stored DTC codes before using the following DTC chart for this code set. Always diagnose and repair any existing codes starting with the lowest numerical code first.

DTC 219-Max Govern Speed Override

Step	Action	Value(s)	Yes	No
1	Did you perform the On-Board (OBD) System Check?	-	Go to Step (2)	Go to OBD System Check Section
2	<ul style="list-style-type: none"> • Key ON, Engine OFF • DST connected Are any other DTC codes present with DTC 219?		Go to Step (3)	Go to Step (4)
3	<ul style="list-style-type: none"> • Diagnose and repair any other DTC codes stored before proceeding with this chart. Have any other DTC codes been diagnosed and repaired?		Go to Step (4)	-
4	<ul style="list-style-type: none"> • Check the service part number on the ECM to ensure the correct calibration is in use Is the Service Part Number Correct?		Go to Step (6)	Go to Step 5
5	<ul style="list-style-type: none"> • Replace ECM with correct service part number Is the replacement complete?		Go to Step (9)	-
6	<ul style="list-style-type: none"> • Check the mechanical operation of the throttle Is the mechanical operation of the throttle OK?		Go to Step (8)	Go to Step (7)
7	<ul style="list-style-type: none"> • Correct mechanical operation of the throttle. Refer to Engine & Component section Has the mechanical operation of the throttle been corrected?		Go to Step (9)	-
8	<ul style="list-style-type: none"> • Check engine for large manifold vacuum leaks. Refer to Symptom Diagnostic section Did you find and correct the vacuum leak?		Go to Step (9)	Go to OBD System Check Section
9	<ul style="list-style-type: none"> • Remove all test equipment except the DST. • Connect any disconnected components, fuses, etc. • Using the DST clear DTC information from the ECM. • Turn the ignition OFF and wait 30 seconds. • Start the engine and operate the vehicle to full operating temperature • Observe the MIL • Observe engine performance and drivability • After operating the engine within the test parameters of DTC-219 check for any stored codes. Does the engine operate normally with no stored codes?		System OK	Go to OBD System Check

DTC 221-TPS 1 Higher Than TPS 2 (SPN 51:FMI 0)

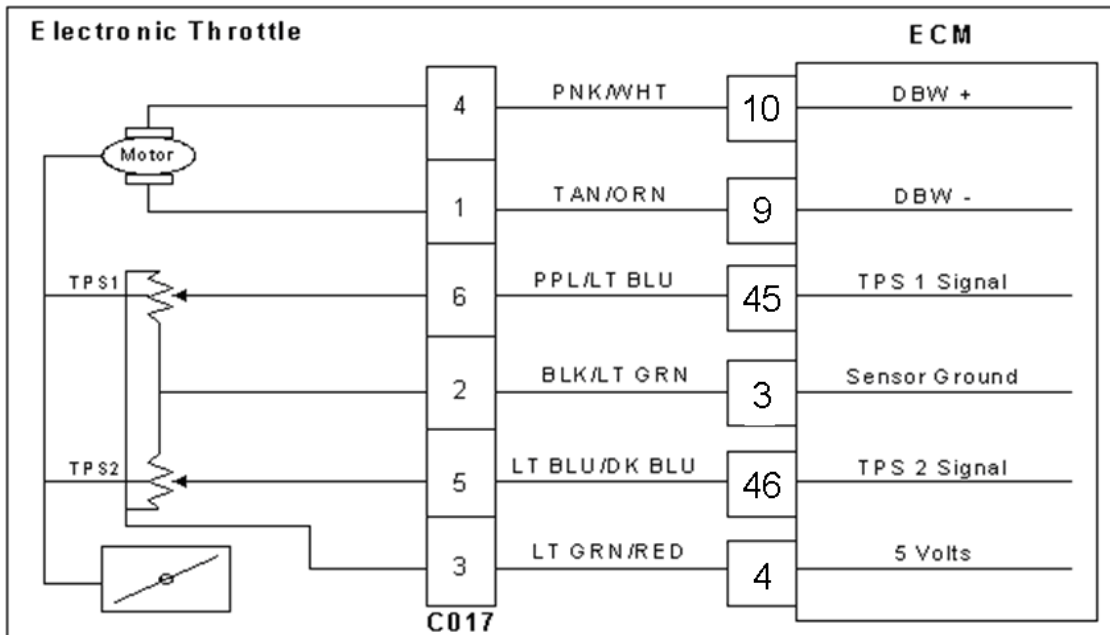

Conditions for Setting the DTC

- Throttle Position Sensor 1 & 2
- Check Condition-Key ON
- Fault Condition-TPS 1 20% higher than TPS2
- MIL-ON for remainder of key on cycle
- Engine shutdown

Circuit Description

Dual throttle Position Sensors are used within the throttle that use variable resistors to determine signal voltage based on throttle plate position. TPS 1 will read lower voltage when closed and TPS 2 will read higher voltage when closed. The TPS 1 and TPS 2 percentages are calculated from these voltages. Although the voltages are different, the calculated values for the throttle position percentages should be very close to the same. The TPS values are used by the ECM to determine if the throttle is opening as commanded. The TPS is not serviceable and in the event of a failure the electronic throttle assembly must be replaced. This fault will set if TPS 1 is 20% (or more) higher than TPS 2. At this point the throttle is considered to be out of specification, or there is a problem with the TPS signal circuit. The MIL command is ON and the engine will shut down.

DTC 221 TPS 1 Higher Than TPS 2

Step	Action	Value(s)	Yes	No
1	Did you perform the On-Board (OBD) System Check?	-	Go to Step (2)	Go to OBD System Check Section
2	<ul style="list-style-type: none"> • Key ON, Engine OFF • DST (Diagnostic Scan Tool) connected in System Data Mode Does the DST display more than a 20% difference between TPS 1 and TPS 2?		Go to Step (3)	Intermittent problem Go to Intermittent section
3	<ul style="list-style-type: none"> • Key OFF • Disconnect electronic throttle connector C017 • Key ON • Change DST mode to DBW (drive by wire) test mode Is the voltage for TPS 1 less than 0.1 volts?		Go to Step (5)	Go to Step (4)
4	<ul style="list-style-type: none"> • Key OFF • Disconnect ECM wiring harness connector C001 • Key ON • Using a DVOM check for voltage between ECM connector TPS 1 signal pin 5 and engine ground Do you have voltage?		Repair the TPS 1 circuit shorted to voltage as necessary. Refer to Wiring Repairs in Engine Electrical.	Go to Step (9)
5	<ul style="list-style-type: none"> • Jump TPS 1 signal pin 6 to the 5 volt reference pin 3 at connector C017 Does DST display TPS 1 voltage over 4.900 volts?		Go to Step (6)	Go to Step (8)
6	<ul style="list-style-type: none"> • Inspect wire terminals at throttle connector for damage corrosion or contamination Any problems found?		Repair the circuit as necessary. Refer to Wiring Repairs in Engine Electrical.	Go to Step (7)
7	<ul style="list-style-type: none"> • Replace the electronic Throttle Is the replacement complete?		Go to Step (12)	-
8	<ul style="list-style-type: none"> • Key OFF • Disconnect ECM wire harness connector C001 • Using a DVOM check for continuity between throttle connector TPS 1 signal pin 6 and ECM connector TPS 1 signal pin 45 Do you have continuity between them?		Go to Step (9)	Repair the open circuit as necessary. Refer to Wiring Repairs in Engine Electrical.

Step	Action	Value(s)	Yes	No
9	<ul style="list-style-type: none"> Using a DVOM check for continuity between throttle connector signal ground pin 2 and ECM connector signal ground pin 3 Do you have continuity between them?		Go to Step (10)	Repair the open circuit as necessary. Refer to Wiring Repairs in Engine Electrical.
10	<ul style="list-style-type: none"> Inspect ECM connector terminals for damage corrosion or contamination. Any problems found?		Repair the circuit as necessary. Refer to Wiring Repairs in Engine Electrical	Go to Step (11)
11	<ul style="list-style-type: none"> Replace ECM Is the replacement complete?		Go to Step (12)	-
12	<ul style="list-style-type: none"> Remove all test equipment except the DST. Connect any disconnected components, fuses, etc. Using the DST clear DTC information from the ECM. Turn the ignition OFF and wait 30 seconds. Start the engine and operate the vehicle to full operating temperature Observe the MIL Observe engine performance and drivability After operating the engine within the test parameters of DTC-221 check for any stored codes. Does the engine operate normally with no stored codes?		System OK	Go to OBD System Check

DTC 222-TPS 2 Signal Voltage Low (SPN 520251:FMI 4)

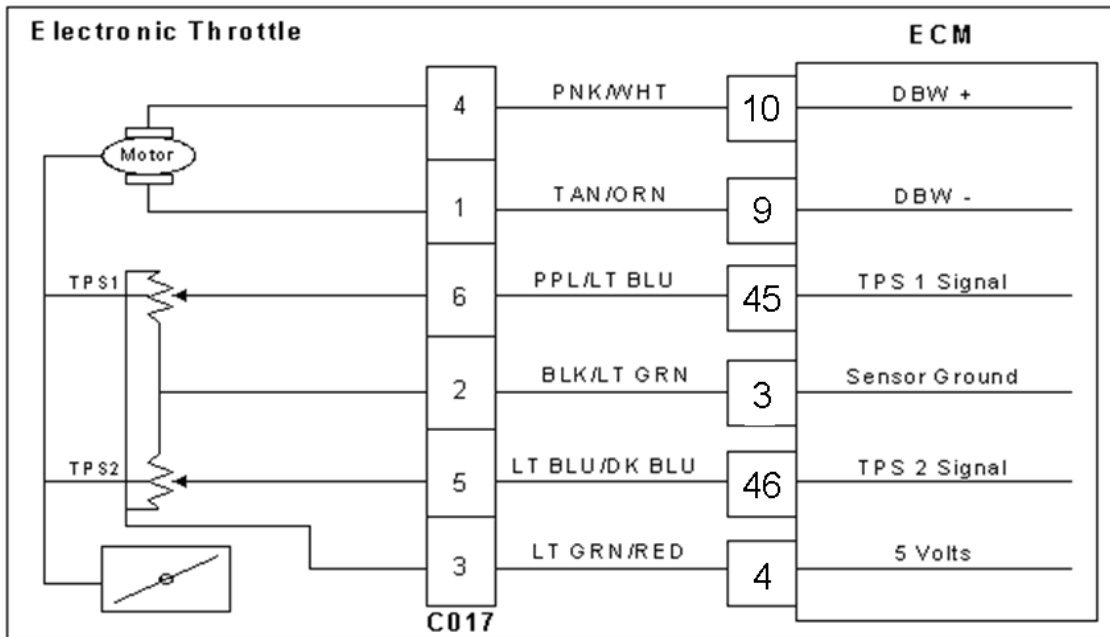

Conditions for Setting the DTC

- Throttle Position Sensor 2
- Check Condition-Cranking or Running
- Fault Condition-TPS 2 sensor voltage less than 0.200 volts
- MIL-ON during active fault
- Engine will Shutdown

Circuit Description

Dual throttle Position Sensors are used within the throttle that use variable resistors to determine signal voltage based on throttle plate position. TPS1 will read lower voltage when closed and TPS2 will read higher voltage when closed. The TPS1 and TPS2 percentages are calculated from these voltages. Although the voltages are different, the calculated values for the throttle position percentages should be very close to the same. The TPS values are used by the ECM to determine if the throttle is opening as commanded. The TPS is not serviceable and in the event of a failure the electronic throttle assembly must be replaced. This fault will set if the TPS 2 voltage is less than 0.200 volts. The MIL command is ON and engine will shutdown.

DTC 222 TPS 2 Signal Voltage Low

Step	Action	Value(s)	Yes	No
1	Did you perform the On-Board (OBD) System Check?	-	Go to Step (2)	Go to OBD System Check Section
2	<ul style="list-style-type: none"> • Key ON, Engine OFF • DST (Diagnostic Scan Tool) connected in DBW (Drive by Wire) throttle test mode Does the DST display TPS 2 voltage of 0.200 volts or less with the throttle closed?		Go to Step (4)	Go to Step (3)
3	<ul style="list-style-type: none"> • Slowly depress Foot Pedal while observing TPS 2 voltage Does TPS 2 voltage ever fall below 0.200 volts?		Go to Step (4)	Intermittent problem Go to Intermittent section
4	<ul style="list-style-type: none"> • Key OFF • Disconnect electronic throttle connector C017 • Jumper the 5 volt reference circuit pin 3 and TPS 2 signal circuit pin 5 together at the throttle connector • Key ON Does DST display TPS 2 voltage of 4.0 volts or greater?		Go to Step (7)	Go to Step (5)
5	<ul style="list-style-type: none"> • Key OFF • Disconnect ECM wire harness connector C001 • Using a DVOM check continuity between TPS 2 connector signal pin 5 and ECM connector TPS 2 Signal pin 46 Do have continuity between them?		Go to Step (6)	Repair the circuit as necessary. Refer to Wiring Repairs in Engine Electrical.
6	<ul style="list-style-type: none"> • Replace ECM Is the replacement complete?		Go to Step (9)	-
7	<ul style="list-style-type: none"> • Inspect the electronic throttle wire harness connector terminals for damage, corrosion or contamination Did you find a problem?		Repair the circuit as necessary. Refer to Wiring Repairs in Engine Electrical.	Go to Step (8)
8	<ul style="list-style-type: none"> • Replace the electronic throttle Is the replacement complete?		Go to Step (9)	-

Step	Action	Value(s)	Yes	No
9	<ul style="list-style-type: none"> • Remove all test equipment except the DST. • Connect any disconnected components, fuses, etc. • Using the DST clear DTC information from the ECM. • Turn the ignition OFF and wait 30 seconds. • Start the engine and operate the vehicle to full operating temperature • Observe the MIL • Observe engine performance and drivability • After operating the engine within the test parameters of DTC-222 check for any stored codes. <p>Does the engine operate normally with no stored codes?</p>		System OK	Go to OBD System Check

DTC 223-TPS 2 Signal Voltage High (SPN 520251:FMI 3)

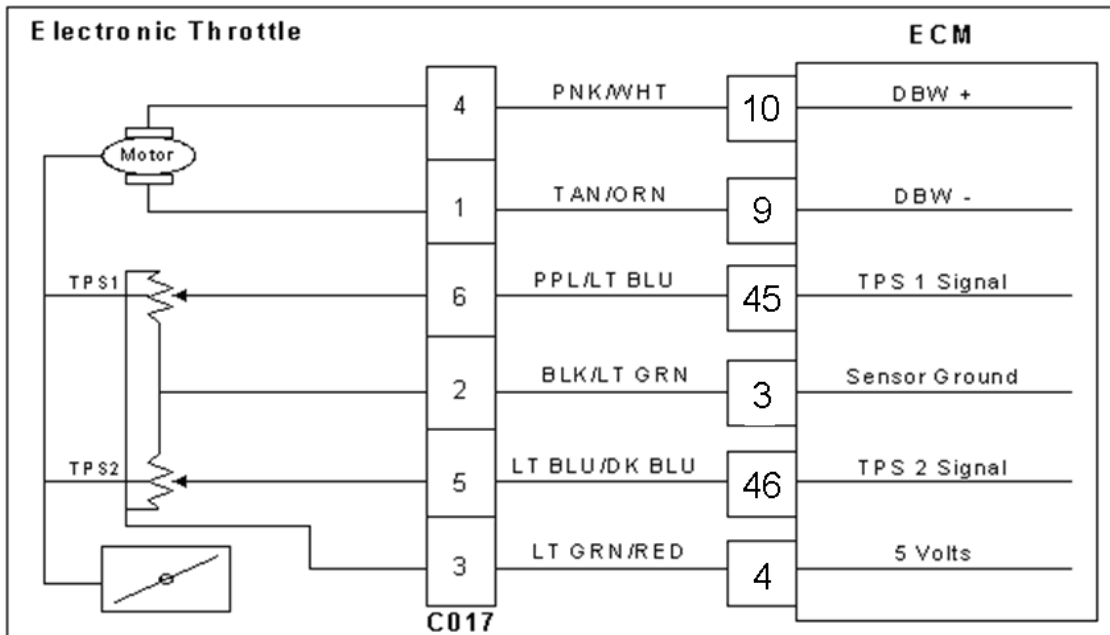

Conditions for Setting the DTC

- Throttle Position Sensor 2
- Check Condition-Cranking or Running
- Fault Condition-TPS 2 sensor exceeds 4.800 volts
- MIL-ON during active fault
- Engine will shutdown

Circuit Description

Dual throttle Position Sensors are used within the throttle that use variable resistors to determine signal voltage based on throttle plate position. TPS1 will read lower voltage when closed and TPS2 will read higher voltage when closed. The TPS1 and TPS2 percentages are calculated from these voltages. Although the voltages are different, the calculated values for the throttle position percentages should be very close to the same. The TPS values are used by the ECM to determine if the throttle is opening as commanded. The TPS is not serviceable and in the event of a failure the electronic throttle assembly must be replaced. This fault will set if the TPS 2 voltage is greater than 4.800 volts. The MIL command is ON and the engine will shutdown.

DTC 223 TPS 2 Signal Voltage High

Step	Action	Value(s)	Yes	No
1	Did you perform the On-Board (OBD) System Check?	-	Go to Step (2)	Go to OBD System Check Section
2	<ul style="list-style-type: none"> • Key ON, Engine OFF • DST (Diagnostic Scan Tool) connected in DBW (Drive by Wire) throttle test mode Does the DST display TPS 2 voltage of 4.800 volts or greater with the throttle closed?		Go to Step (4)	Go to Step (3)
3	<ul style="list-style-type: none"> • Slowly depress Foot Pedal while observing TPS 2 voltage Does TPS 2 voltage ever exceed 4.800 volts?		Go to Step (4)	Intermittent problem Go to Intermittent section
4	<ul style="list-style-type: none"> • Key OFF • Disconnect electronic throttle connector C017 • Key ON Does DST display TPS 2 voltage less than 0.2 volts?		Go to Step (7)	Go to Step (5)
5	<ul style="list-style-type: none"> • Key OFF • Disconnect ECM wire harness connector C001 • Key ON • Using a DVOM check for voltage between electronic throttle connector TPS 2 signal pin 5 and engine ground Do you have voltage?		Repair the circuit as necessary. Refer to Wiring Repairs in Engine Electrical.	Go to Step (6)
6	<ul style="list-style-type: none"> • Replace ECM Is the replacement complete?		Go to Step (11)	-
7	<ul style="list-style-type: none"> • Probe sensor ground circuit at the ECM side of the wire harness pin 3 with a test light connected to battery voltage Does the test light come on?		Go to Step (8)	Go to Step (10)
8	<ul style="list-style-type: none"> • Inspect the electronic throttle wire harness connector and terminals for damage, corrosion or contamination Did you find a problem?		Repair the circuit as necessary. Refer to Wiring Repairs in Engine Electrical.	Go to Step (9)
9	<ul style="list-style-type: none"> • Replace electronic throttle Is the replacement complete?		Go to Step (11)	-
10	<ul style="list-style-type: none"> • Key OFF • Disconnect ECM connector C001 • Using a DVOM check for continuity between throttle connector C017 sensor ground pin 2 and ECM connector sensor ground pin 3 Do have continuity between them?		Go to Step (6)	Repair the circuit as necessary. Refer to Wiring Repairs in Engine Electrical.

Step	Action	Value(s)	Yes	No
11	<ul style="list-style-type: none"> • Remove all test equipment except the DST. • Connect any disconnected components, fuses, etc. • Using the DST clear DTC information from the ECM. • Turn the ignition OFF and wait 30 seconds. • Start the engine and operate the vehicle to full operating temperature • Observe the MIL • Observe engine performance and drivability • After operating the engine within the test parameters of DTC-223 check for any stored codes. <p>Does the engine operate normally with no stored codes?</p>		System OK	Go to OBD System Check

DTC 336-Crank Sync Noise (SPN 636:FMI 2)

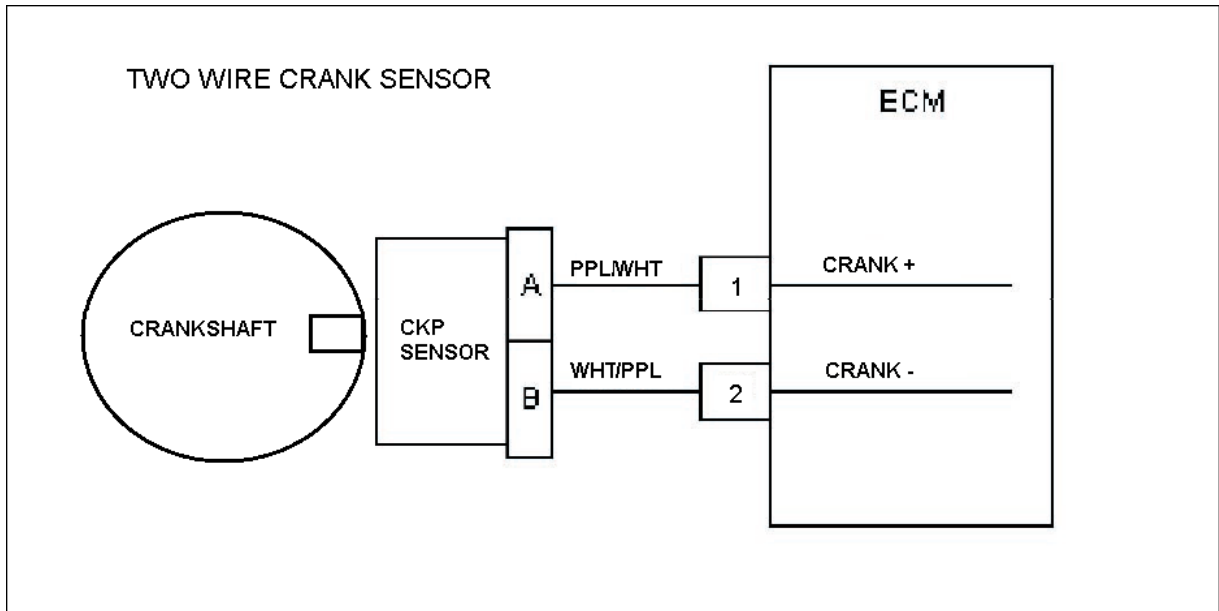

Conditions for setting the DTC

- Crankshaft Position sensor
- Check Condition- Engine running
- Fault Condition- 1 invalid crank re-sync in less than 800ms
- Adaptive- Disabled
- MIL- On during active fault

Circuit Description

The CKP (crankshaft position sensor) is a magnetic transducer mounted on the engine block adjacent to a pulse wheel located on the crankshaft. It determines crankshaft position by monitoring the pulse wheel. The Crankshaft Position sensor is used to measure engine RPM and its signal is used to synchronize the ignition and fuel systems. This fault will set if 1 invalid crank re-sync occurs in less than 800ms.

The cause of this failure could be a faulty reluctor wheel, faulty sensor, faulty wiring, or a faulty ECM. The technician should troubleshoot the wiring and the sensor first. If these parts test okay visually inspect the reluctor wheel for damage.

DTC 337-Crank Loss (SPN 636:FMI 4)

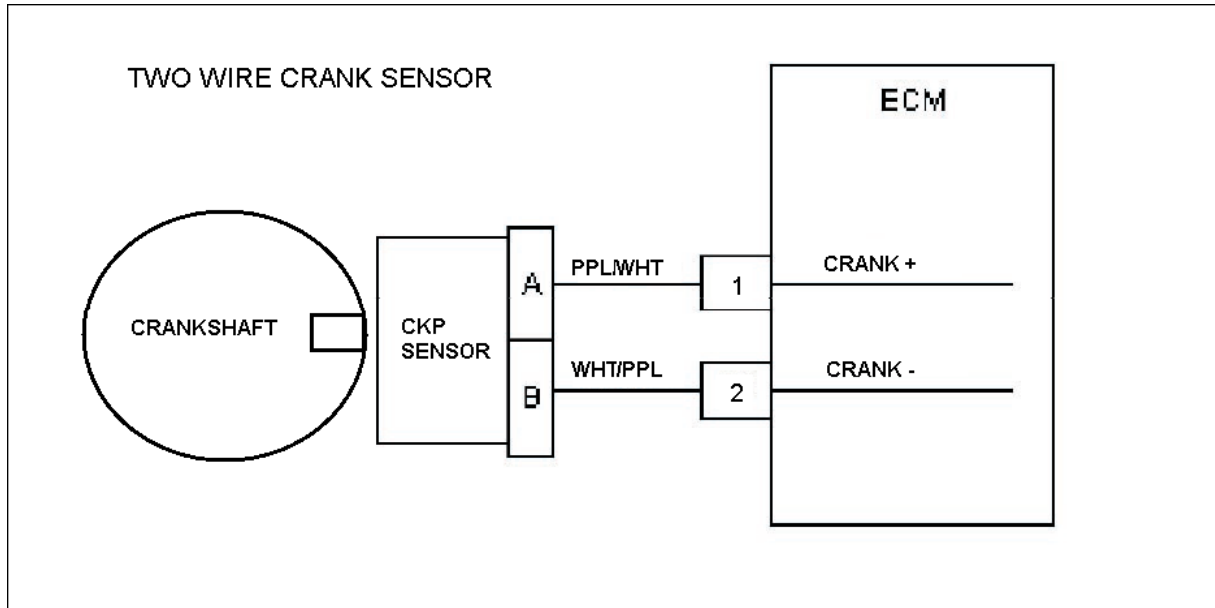

Conditions for setting the DTC

- Crankshaft position sensor
- Check Condition - Engine cranking
- Fault Condition - 6 cam pulse signals without crankshaft activity
- MIL - On during active fault
- Adaptive- Disabled

Circuit Description

The CKP (crankshaft position sensor) is a magnetic transducer mounted on the engine block adjacent to a pulse wheel located on the crankshaft. It determines crankshaft position by monitoring the pulse wheel. The Crankshaft Position sensor is used to measure engine RPM and its signal is used to synchronize the ignition and fuel systems. If no crankshaft signal is present for 6 cam pulses this fault will set.

DTC-359 Fuel Run-out Longer Than Expected (SPN 1239:FMI 7)

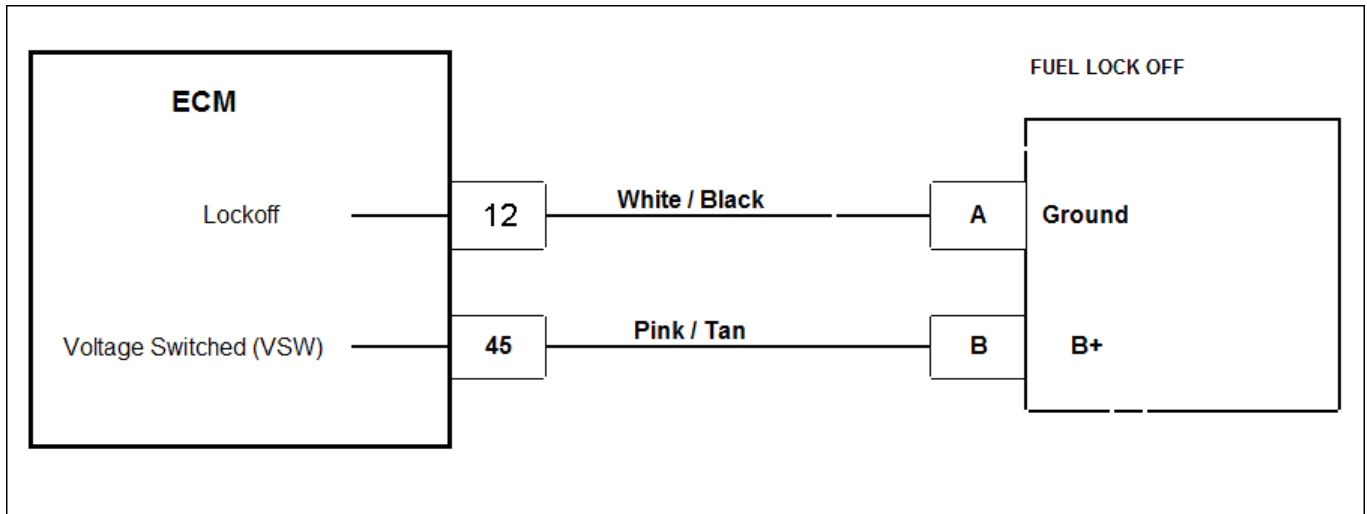

Conditions for Setting the DTC

- LPG lock-off valve
- Check Condition-Key OFF
- Fault Condition-Engine run down time greater than 20 seconds
- MIL-ON

Circuit Description

The LPG lock off valve is supplied system battery power from the VSW fused source. The ECM then provides a path to ground to turn the valve on. This fault will set in the event the engine continues to run for more than 20 seconds after the key is turned off. This fault indicates a possible problem with the electric LPG lock off solenoid.

DTC-359 Fuel Run-out Longer Than Expected

Step	Action	Value(s)	Yes	No
1	Did you perform the On-Board (OBD) System Check?	-	Go to Step (2)	
2	<ul style="list-style-type: none"> • Disconnect the LPG shut off solenoid connector C003 • Using a DVOM check for power across terminals A and B while cranking the engine, then turn the key to the OFF position Did the voltage immediately turn OFF with the key cycle?	System Voltage	Go to Step (3)	Go to Step (5)
3	<ul style="list-style-type: none"> • Turn off the LPG manual valve at the fuel tank • Start the engine and let it idle until the engine stops. (THIS MAY TAKE SEVERAL MINUTES) Did the engine ever stop?		Intermittent problem. See intermittent problems in the electrical section of this manual.	Go to Step (4)
4	<ul style="list-style-type: none"> • Replace the LPG shut off solenoid Is the replacement complete?		Go to Step (8)	-
5	<ul style="list-style-type: none"> • Key OFF • Disconnect the ECM wire harness connector C001 • Using a DVOM check for continuity between ECM pin 12 and engine ground Do you have continuity?		Repair the LPG solenoid control short to ground	Go to Step (6)
6	<ul style="list-style-type: none"> • Inspect the ECM wire harness and connector for damage corrosion or contamination Did you find a problem?		Correct the problem as required. See wire harness repair.	Go to Step (7)
7	<ul style="list-style-type: none"> • Replace the ECM Is the replacement complete?		Go to Step (8)	-
8	<ul style="list-style-type: none"> • Remove all test equipment except the DST. • Connect any disconnected components, fuses, etc. • Using the DST clear DTC information from the ECM. • Turn the ignition OFF and wait 30 seconds. • Start the engine and operate the vehicle to full operating temperature • Observe the MIL • Observe engine performance and drivability • After operating the engine within the test parameters of DTC-359 check for any stored codes. Does the engine operate normally with no stored codes?		System OK	Go to OBD System Check

DTC 524-Oil Pressure Low Stage 2 (SPN 100:FMI 1)

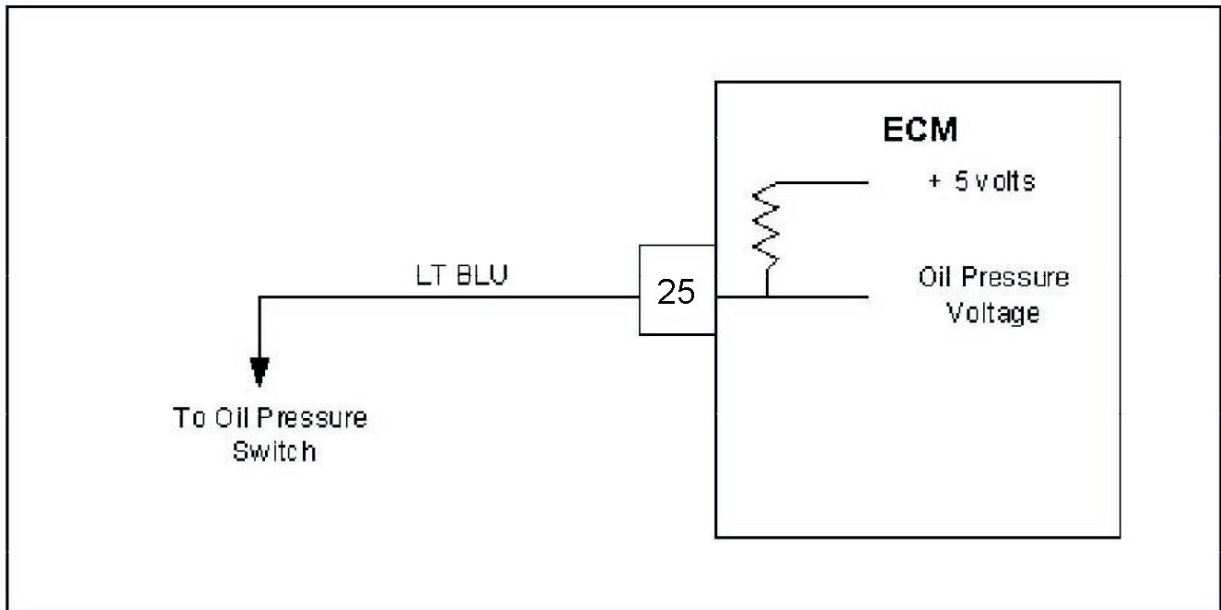

Conditions for Setting the DTC

- Engine Oil Pressure low.
- Fault Condition- Closed circuit/voltage low less than 2.5 volts
- MIL-On during active fault
- Engine Shut Down.

Circuit Description

The Oil Pressure Sender is used to communicate the oil pressure condition to the ECM. Engine damage can occur if the engine is operated with low oil pressure. The ECM uses an analog voltage input with an internal 5 volt reference. If the oil pressure circuit is grounded, the input voltage will be near zero. If it is open, the input will be near 5 volts. The switch is normally closed. This fault will set if the switch remains closed with the engine running. The MIL command is on and the engine will shut down in the event of this fault to help prevent possible engine damage.

DTC 524-Oil Pressure Low

Step	Action	Value(s)	Yes	No
1	Did you perform the On-Board (OBD) System Check?	-	Go to Step (2)	Go to OBD System Check Section
2	<ul style="list-style-type: none"> • Verify that the engine has oil pressure using a mechanical oil pressure gauge before proceeding with this chart. See Engine Specifications Section 1F. Does the engine have oil pressure above 2 psi?	2 psi	Go to Step (3)	Repair faulty Oiling System
3	<ul style="list-style-type: none"> • Key ON, Engine Running DST connected in System Data Mode • Clear DTC 524 • Warm the engine by idling until the ECT temperature is above 160 degrees F. and has been running for at least 20 seconds or more • Increase engine speed above 600 RPM Does DTC 524 reset and cause the engine to shut down?		Go to Step (4)	Intermittent problem Go to Intermittent section
4	<ul style="list-style-type: none"> • Key Off • Disconnect the oil pressure switch harness connector. • Clear DTC 524 • Start engine, let idle for at least one minute with ECT over 160 degrees F. • Increase engine speed above 600 RPM Does DTC 524 reset?		Go to Step (6)	Go to Step (5)
5	<ul style="list-style-type: none"> • Replace oil pressure switch Do you have a 5v reference coming out of the ECM?		Go to Step (9)	-
6	<ul style="list-style-type: none"> • Key Off • Disconnect ECM harness connector • Using a DVOM check for continuity between oil pressure switch connector LT Grn/Blk Wire and engine ground. • Do you have continuity between them? 		Repair the circuit as necessary. Refer to Wiring repairs in engine electrical.	Go to Step (7)
7	<ul style="list-style-type: none"> • Inspect ECM connector pin 25 for damage corrosion or contamination. Did you find a problem?		Repair the circuit as necessary. Refer to wiring repairs in Engine electrical.	Go to Step (8)

Step	Action	Value(s)	Yes	No
8	<ul style="list-style-type: none"> • Replace ECM Is the replacement complete?		Go to Step (9)	-
9	<ul style="list-style-type: none"> • Remove all test equipment except the DST. • Connect any disconnected components, fuses, etc. • Using the DST clear DTC information from the ECM. • Turn the ignition OFF and wait 30 seconds. • Start the engine and operate the vehicle to full operating temperature • Observe the MIL • Observe engine performance and drivability • After operating the engine within the test parameters of DTC-524 check for any stored codes. Does the engine operate normally with no stored codes?		System OK	Go to OBD System Check

DTC 562-System Voltage Low (SPN 168:FMI 17)

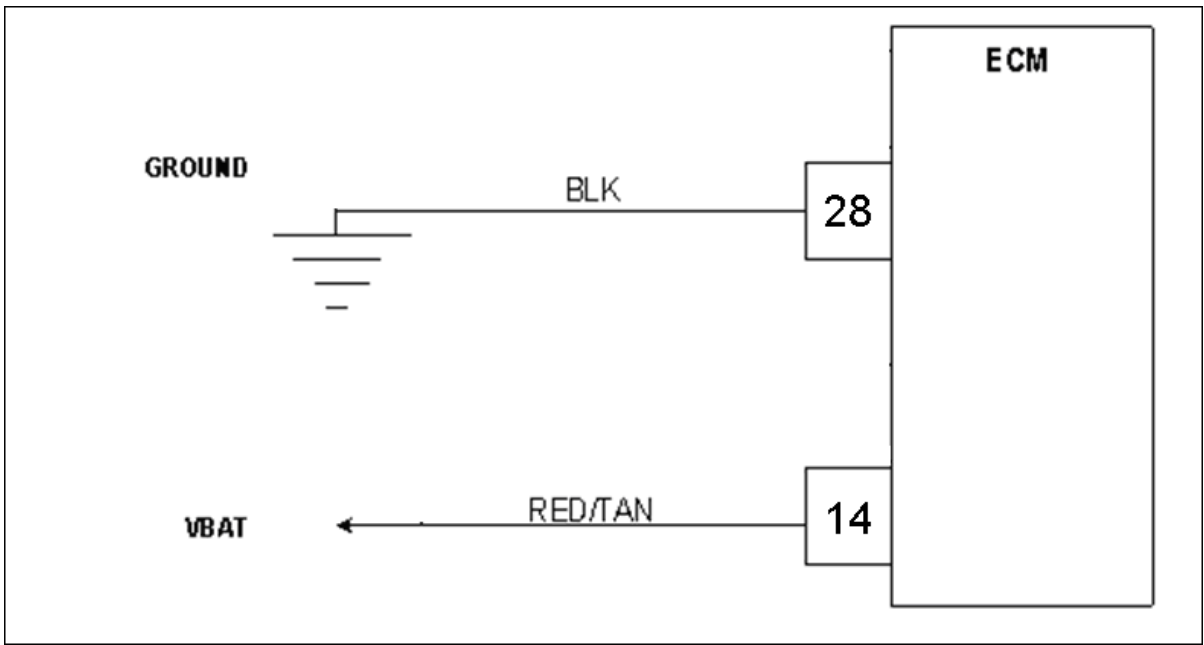

Conditions for Setting the DTC

- System Voltage to ECM
- Check Condition-Key on with engine speed greater than 1000 RPM
- Fault Condition-Battery voltage at ECM less than 9.0
- Fault Condition is present for longer than 5 seconds.
- MIL-ON for active fault
- Adaptive-Disabled

Circuit Description

The battery voltage powers the ECM and must be measured to correctly to properly operate injector drivers, solenoid valves and ignition coils. This fault will set if the ECM detects system voltage less than 9.00 volts while the alternator should be charging. The adaptive learn is disabled during this fault.

DTC 562-System Voltage Low

Step	Action	Value(s)	Yes	No
1	Did you perform the On-Board (OBD) System Check?	-	Go to Step (2)	Go to OBD System Check Section
2	<ul style="list-style-type: none"> • Key ON, Engine Running • DST (Diagnostic Scan Tool) connected in System Data Mode Does DST display system voltage greater than 9.50 volts?	-	Intermittent problem Go to Engine Electrical Intermittent section	Go to Step (3)
3	<ul style="list-style-type: none"> • Check battery condition Is it OK?	-	Go to Step (4)	Replace Battery
4	<ul style="list-style-type: none"> • Check charging system Is it OK?	-	Go to Step (5)	Repair charging System
5	<ul style="list-style-type: none"> • Key OFF • Disconnect the ECM connector C001 • Check the voltage between ECM connector C001 pin 14 and engine ground. • Measure voltage with DVOM between each pin and engine ground Is the voltage greater than 9.50 volts?	-	Repair ECM Ground circuit. Go to Power and Ground section in engine Electrical	Go to Step (6)
6	<ul style="list-style-type: none"> • Check the voltage at ECM connector pin 28 • Measure voltage with DVOM between the pin and battery positive Is the voltage greater than 9.50 volts?	-	Repair ECM power circuit. Go to Power and Ground Section in engine Electrical	Go to Step (7)
7	<ul style="list-style-type: none"> • Replace ECM Is the replacement complete?	-	Go to Step (8)	-
8	<ul style="list-style-type: none"> • Remove all test equipment except the DST. • Connect any disconnected components, fuses, etc. • Using the DST clear DTC information from the ECM. • Turn the ignition OFF and wait 30 seconds. • Start the engine and operate the vehicle to full operating temperature • Observe the MIL • Observe engine performance and drivability • After operating the engine within the test parameters of DTC-562 check for any stored codes. Does the engine operate normally with no stored codes?	-	System OK	Go to OBD System Check

DTC 563-System Voltage High (SPN 168:FMI 15)

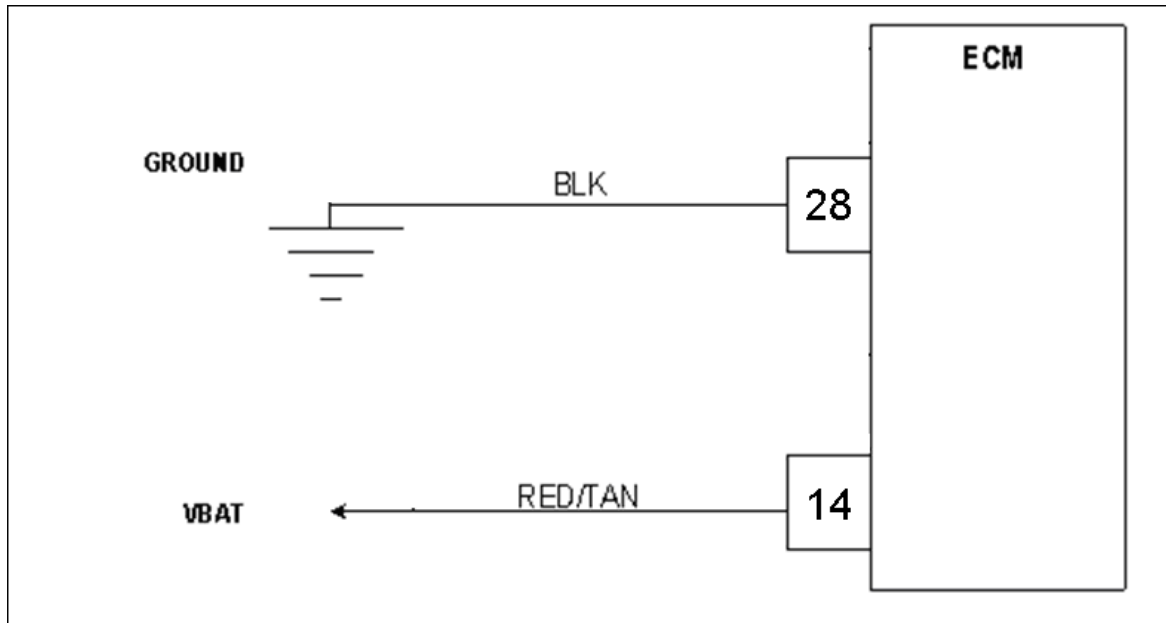

Conditions for Setting the DTC

- System Voltage to ECM
- Check Condition-Cranking or Running
- Fault Condition-System battery voltage at ECM greater than 18 volts
- Fault must be present for 3 or more seconds
- MIL-ON for active fault
- Adaptive-Disabled

Circuit Description

The battery voltage powers the ECM and must be measured to correctly operate injector drivers, trim valves and ignition coils. This fault will set if the ECM detects voltage greater than 18 volts anytime the engine is cranking or running. The adaptive learn function is disabled during this fault. The ECM will shut down with internal protection if the system voltage ever exceeds 26 volts.

DTC 563-System Voltage High

Step	Action	Value(s)	Yes	No
1	Did you perform the On-Board (OBD) System Check?	-	Go to Step (2)	Go to OBD System Check Section
2	<ul style="list-style-type: none"> • Key ON, Engine Running • DST (Diagnostic Scan Tool) connected in System Data Mode • Run engine greater than 1500 rpm. Does DST display system voltage greater than 18 volts?	-	Go To Step (3)	Intermittent problem Go to Engine Electrical Intermittent section
3	<ul style="list-style-type: none"> • Check voltage at battery terminals with DVOM with engine speed greater than 1500 rpm Is it greater than 18 volts?	-	Go to Step (4)	Go to Step (5)
4	<ul style="list-style-type: none"> • Repair the charging system Has the charging system been repaired?	-	Go to Step (6)	-
5	<ul style="list-style-type: none"> • Replace ECM Is the replacement complete?	-	Go to Step (6)	-
6	<ul style="list-style-type: none"> • Remove all test equipment except the DST. • Connect any disconnected components, fuses, etc. • Using the DST clear DTC information from the ECM. • Turn the ignition OFF and wait 30 seconds. • Start the engine and operate the vehicle to full operating temperature • Observe the MIL • Observe engine performance and drivability • After operating the engine within the test parameters of DTC-563 check for any stored codes. Does the engine operate normally with no stored codes?	-	System OK	Go to OBD System Check

DTC 601-Flash Checksum Invalid (SPN 628:FMI 13)

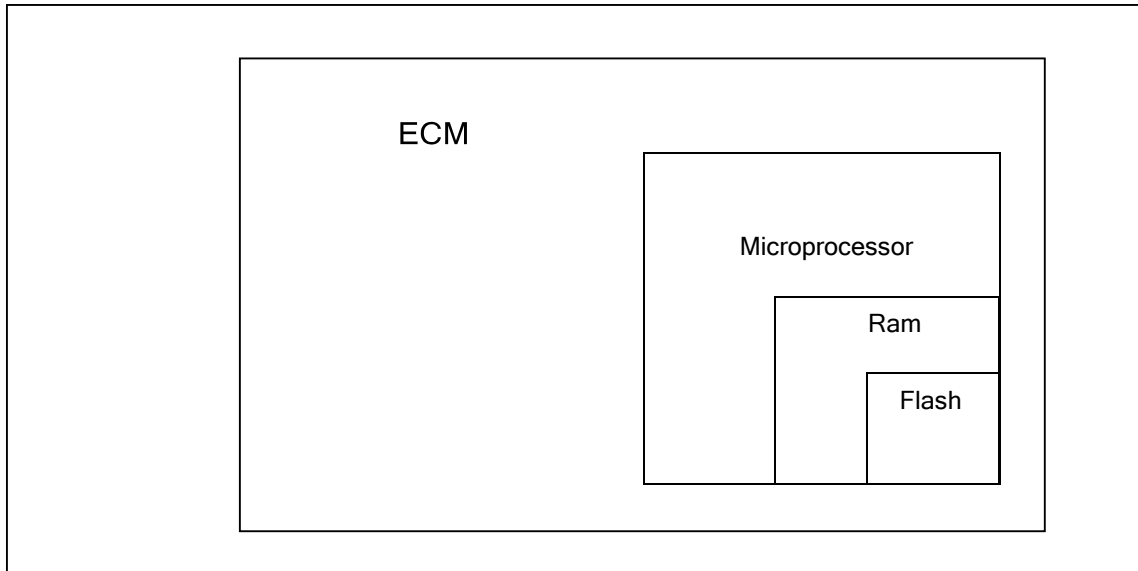

Conditions for Setting the DTC

- Engine Control Module
- Check Condition-Key on
- Fault Condition-Internal microprocessor error
- MIL-ON
- Engine Shutdown will occur

Circuit Description

The ECM has several internal checks that must be satisfied each time an instruction is executed. Several different things can happen within the microprocessor that will cause this fault. The ECM will attempt to reset itself in the event this fault is set. The MIL command is on and will remain on until the code is cleared using the DST. The engine will shut down when this fault occurs.

DTC 601-Flash Checksum Invalid

Step	Action	Value(s)	Yes	No
1	Did you perform the On-Board (OBD) System Check?	-	Go to Step (2)	Go to OBD System Check Section
2	<ul style="list-style-type: none"> • Key ON, Engine Running • DST (Diagnostic Scan Tool) connected in System Data Mode • Clear system fault code Does DTC 601 reset with the engine idling?		Go to Step (3)	Intermittent problem Go to Intermittent section
3	<ul style="list-style-type: none"> • Check ECM power and ground circuits Did the power and ground circuits check OK?		Go to Step (4)	Repair the circuit as necessary. Refer to Wiring Repairs in Engine Electrical.
4	<ul style="list-style-type: none"> • Replace ECM Is the replacement complete?		Go to Step (5)	-
5	<ul style="list-style-type: none"> • Remove all test equipment except the DST. • Connect any disconnected components, fuses, etc. • Using the DST clear DTC information from the ECM. • Turn the ignition OFF and wait 30 seconds. • Start the engine and operate the vehicle to full operating temperature • Observe the MIL • Observe engine performance and drivability • After operating the engine within the test parameters of DTC-601 check for any stored codes. Does the engine operate normally with no stored codes?		System OK	Go to OBD System Check

DTC 604-RAM Failure (SPN 630:FMI 12)

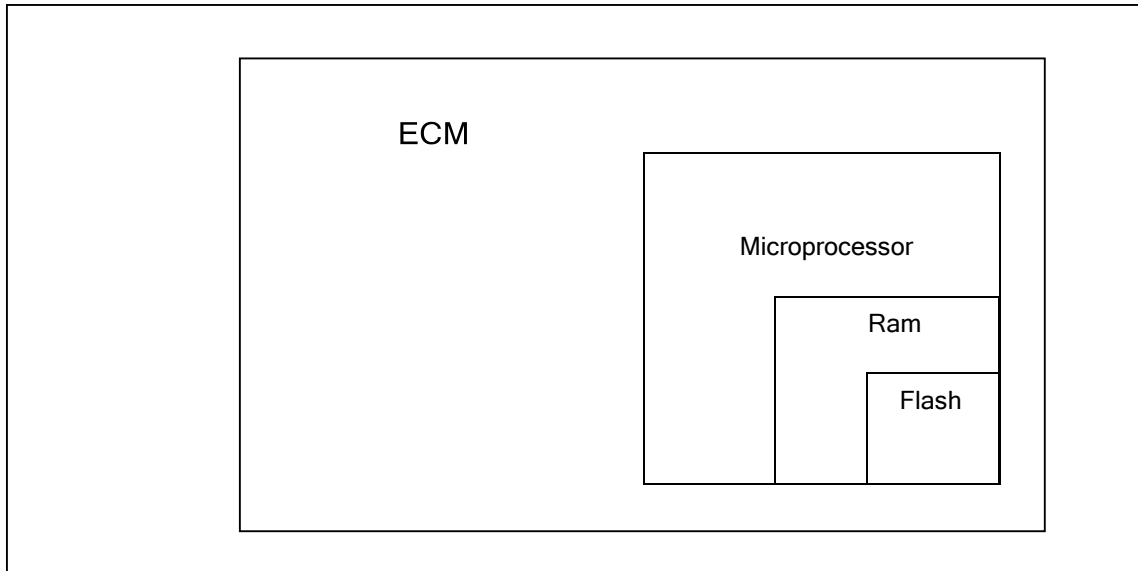

Conditions for Setting the DTC

- Engine Control Module
- Check Condition-Key on
- Fault Condition-Internal microprocessor error
- MIL-ON
- Engine Shutdown will occur

Circuit Description

The ECM has several internal checks that must be satisfied each time an instruction is executed. Several different things can happen within the microprocessor that will cause this fault. The ECM will attempt to reset itself in the event this fault is set. The MIL command is on and will remain on until the code is cleared using the DST. The engine will shut down if this fault occurs.

DTC 604-RAM Failure

Step	Action	Value(s)	Yes	No
1	Did you perform the On-Board (OBD) System Check?	-	Go to Step (2)	Go to OBD System Check Section
2	<ul style="list-style-type: none"> • Key ON, Engine Running • DST (Diagnostic Scan Tool) connected in System Data Mode • Clear system fault code Does DTC 604 reset with the engine idling?		Go to Step (3)	Intermittent problem Go to Intermittent section
3	<ul style="list-style-type: none"> • Check ECM power and ground circuits Did the power and ground circuits check OK?		Go to Step (4)	Repair the circuit as necessary. Refer to Wiring Repairs in Engine Electrical.
4	<ul style="list-style-type: none"> • Replace ECM Is the replacement complete?		Go to Step (5)	-
5	<ul style="list-style-type: none"> • Remove all test equipment except the DST. • Connect any disconnected components, fuses, etc. • Using the DST clear DTC information from the ECM. • Turn the ignition OFF and wait 30 seconds. • Start the engine and operate the vehicle to full operating temperature • Observe the MIL • Observe engine performance and drivability • After operating the engine within the test parameters of DTC-604 check for any stored codes. Does the engine operate normally with no stored codes?		System OK	Go to OBD System Check

DTC 606-COP Failure (SPN 629:FMI 31)

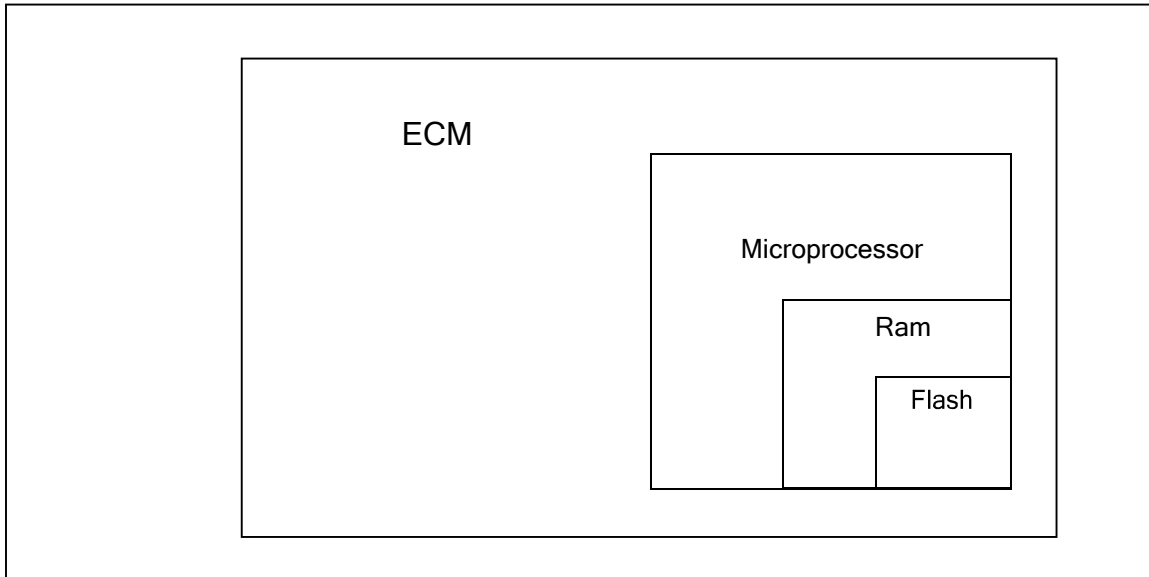

Conditions for Setting the DTC

- Engine Control Module
- Check Condition-Key on
- Fault Condition-Internal microprocessor error
- MIL-ON
- Engine Shutdown will occur

Circuit Description

The ECM has several internal checks that must be satisfied each time an instruction is executed. Several different things can happen within the microprocessor that will cause this fault. The ECM will attempt to reset itself in the event this fault is set. The MIL command is on and will remain on until the code is cleared using the DST. The engine will shut down if this fault occurs.

DTC 606-COP Failure

Step	Action	Value(s)	Yes	No
1	Did you perform the On-Board (OBD) System Check?	-	Go to Step (2)	Go to OBD System Check Section
2	<ul style="list-style-type: none"> • Key ON, Engine Running • DST (Diagnostic Scan Tool) connected in System Data Mode • Clear system fault code Does DTC 606 reset with the engine idling?		Go to Step (3)	Intermittent problem Go to Intermittent section
3	<ul style="list-style-type: none"> • Check ECM power and ground circuits Are the power and ground circuits OK?		Go to Step (4)	Repair the circuit as necessary. Refer to Wiring Repairs in Engine Electrical.
4	<ul style="list-style-type: none"> • Replace ECM Is the replacement complete?		Go to Step (5)	-
5	<ul style="list-style-type: none"> • Remove all test equipment except the DST. • Connect any disconnected components, fuses, etc. • Using the DST clear DTC information from the ECM. • Turn the ignition OFF and wait 30 seconds. • Start the engine and operate the vehicle to full operating temperature • Observe the MIL • Observe engine performance and drivability • After operating the engine within the test parameters of DTC-606 check for any stored codes. Does the engine operate normally with no stored codes?		System OK	Go to OBD System Check

DTC 627-Fuel Pump Relay Coil Open (SPN 1348:FMI 5)

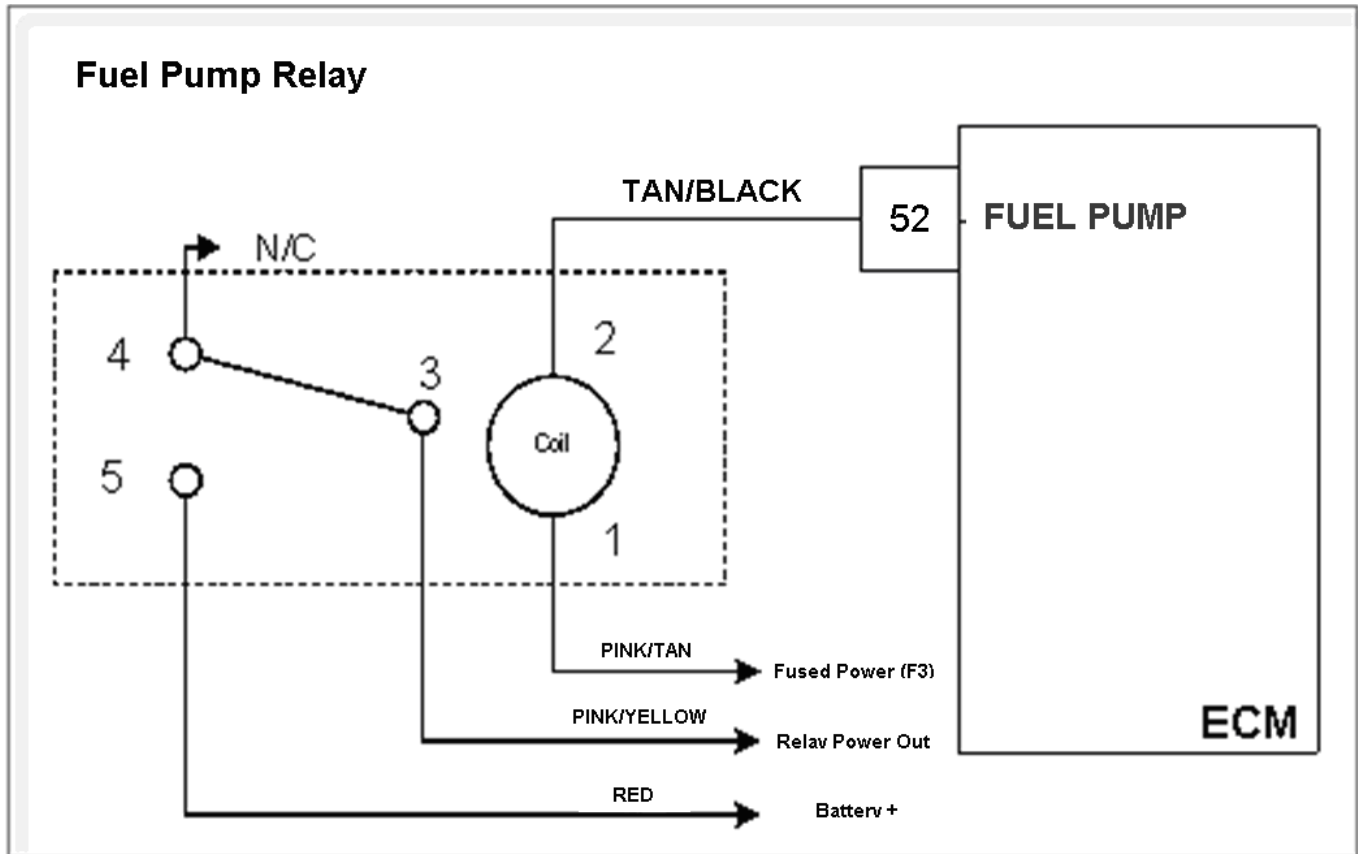

Conditions for Setting the DTC

- Fuel Pump relay check
- Check Condition-Key ON
- Fault Condition-Relay coil open

Circuit Description

The fuel pump relay switches power out to the gasoline fuel pump. This fault will set if the ECM detects an open circuit on the relay control output.

Diagnostic Aid

Relay coil resistance changes with temperature. The following diagnostic charts have steps to measure relay coil resistance values. When checking the resistance values be sure the relay is at a reasonable temperature, between +20 and +100 degrees F.

DTC 627-Fuel Pump Relay Coil Open

Step	Action	Value(s)	Yes	No
1	Did you perform the On-Board (OBD) System Check?	-	Go to Step (2)	Go to OBD System Check Section
2	<ul style="list-style-type: none"> • DST connected and in the system data mode • Key OFF • Remove the power relay from the fuse block • Using a DVOM check the resistance of the relay coil between terminals 1 and 2 Is the resistance value less than 100 ohms?		Go to Step (4)	Go to Step (3)
3	<ul style="list-style-type: none"> • Replace the fuel pump relay Is the replacement complete?		Go to Step (9)	-
4	<ul style="list-style-type: none"> • Check fuse F3 Is the fuse open?		Replace fuse F2	Go to Step (5)
5	<ul style="list-style-type: none"> • Disconnect ECM connector C001 • Using a DVOM check for continuity between ECM pin 52 and fuse block cavity for relay terminal 2 Do you have continuity?		Go to Step (6)	Repair the open circuit as required. See wiring harness repairs
6	<ul style="list-style-type: none"> • Remove fuse F3 • Using a DVOM check for continuity between fuse block cavity for relay terminal 1 and the power out of the F3 fuse holder Do you have continuity?		Go to Step (7)	Repair the open circuit as required. See wiring harness repairs
7	<ul style="list-style-type: none"> • Check all system fuses. • Check all relay placement positions in fuse block. • Run complete pin to pin checks on chassis wiring to fuel system harness. • See complete fuel system schematic for further details Did you find the problem?		Go to Step (9)	Go to Step (8)

Step	Action	Value(s)	Yes	No
8	<ul style="list-style-type: none"> • Replace the ECM Is the replacement complete?		Go to Step (9)	–
9	<ul style="list-style-type: none"> • Remove all test equipment except the DST. • Connect any disconnected components, fuses, etc. • Using the DST clear DTC information from the ECM. • Turn the ignition OFF and wait 30 seconds. • Start the engine and operate the vehicle to full operating temperature • Observe the MIL • Observe engine performance and drivability • After operating the engine within the test parameters of DTC-627 check for any stored codes. Does the engine operate normally with no stored codes?		System OK	Go to OBD System Check

DTC 628- Fuel Pump Relay Control Ground Short (SPN 1347:FMI 5)

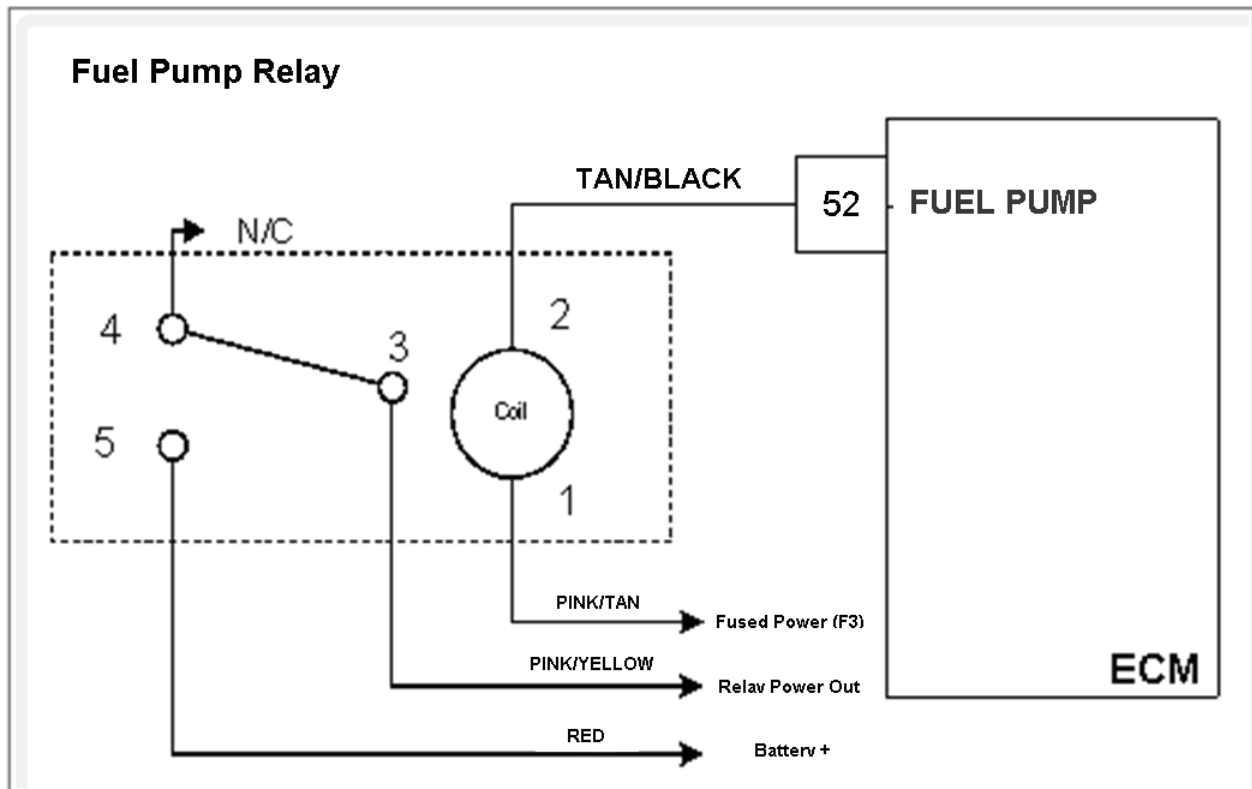

Conditions for Setting the DTC

- Fuel Pump relay ground control
- Check Condition-Key ON
- Fault Condition-Relay control shorted to ground

Circuit Description

The fuel pump relay switches power out to the gasoline fuel pump. This fault will set if the ECM detects an open circuit on the relay control output

Diagnostic Aid

Relay coil resistance changes with temperature. The following diagnostic charts have steps to measure relay coil resistance values. When checking the resistance values be sure the relay is at a reasonable temperature, between +20 and +100 degrees F.

DTC 628- Fuel Pump Relay Control Ground Short

Step	Action	Value(s)	Yes	No
1	Did you perform the On-Board (OBD) System Check?	-	Go to Step (2)	Go to OBD System Check Section
2	<ul style="list-style-type: none"> • Key ON, DST connected in the System Data mode • Clear DTC 628 • Start the engine Does DTC 628 re-set?		Go to Step (4)	Intermittent problem Go to Intermittent section
3	<ul style="list-style-type: none"> • Disconnect ECM connector C001 • Using a DVOM check the resistance value between ECM pin 52 and engine ground Is the resistance less than 60 ohms?		Go to Step (5)	Go to Step (7)
4	<ul style="list-style-type: none"> • Remove the fuel pump relay from the fuse block • Using a DVOM check the resistance value again between ECM pin 52 and engine ground Is the resistance less than 60 ohms?		Repair the shorted to ground relay control circuit as necessary. See wiring harness repairs	Go to Step (6)
5	<ul style="list-style-type: none"> • Replace the fuel pump relay Is the replacement complete?		Go to Step (8)	–
6	<ul style="list-style-type: none"> • Replace ECM Is the replacement complete?		Go to Step (8)	–
7	<ul style="list-style-type: none"> • Remove all test equipment except the DST. • Connect any disconnected components, fuses, etc. • Using the DST clear DTC information from the ECM. • Turn the ignition OFF and wait 30 seconds. • Start the engine and operate the vehicle to full operating temperature • Observe the MIL • Observe engine performance and drivability • After operating the engine within the test parameters of DTC-628 check for any stored codes. Does the engine operate normally with no stored codes?		System OK	Go to OBD System Check

DTC 629- Fuel Pump Relay Coil Short to Power (SPN 1347:FMI 3)

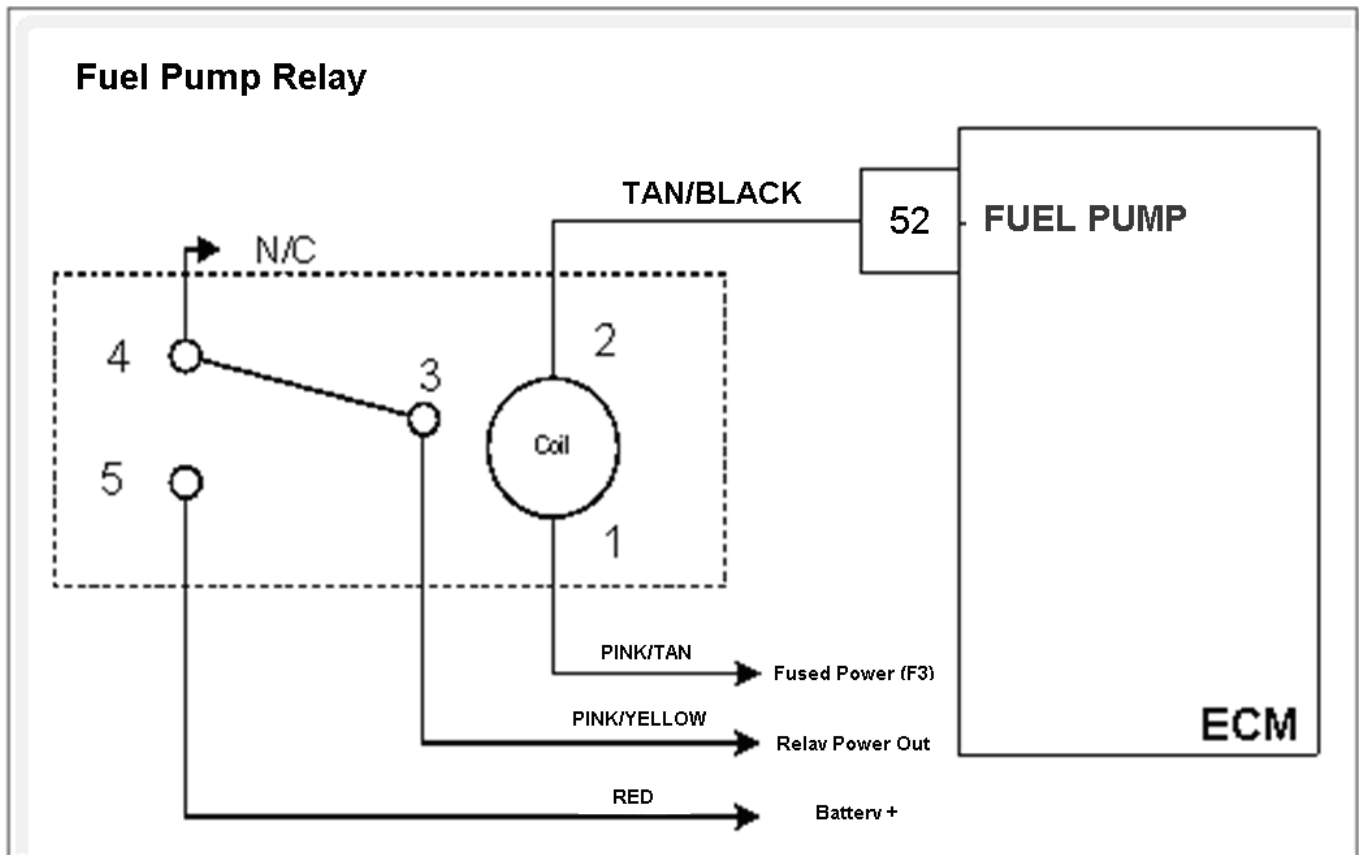

Conditions for Setting the DTC

- Fuel pump relay check
- Check Condition-Key ON
- Fault Condition-Relay coil shorted to power

Circuit Description

The fuel pump relay switches power out to the gasoline fuel pump. This fault will set if the ECM detects an open circuit on the relay control output

Diagnostic Aid

Relay coil resistance changes with temperature. The following diagnostic charts have steps to measure relay coil resistance values. When checking the resistance values be sure the relay is at a reasonable temperature, between +20 and +100 degrees F.

DTC 629- Fuel Pump Relay Coil Short to Power

Step	Action	Value(s)	Yes	No
1	Did you perform the On-Board (OBD) System Check?	-	Go to Step (2)	Go to OBD System Check Section
2	<ul style="list-style-type: none"> • DST connected and in the system data mode • Key OFF • Remove the power relay from the fuse block • Using a DVOM check the resistance of the relay coil between terminals 1 and 2 Is the resistance value less than 60 ohms?		Go to Step (3)	Go to Step (4)
3	<ul style="list-style-type: none"> • Replace the power relay Is the replacement complete?		Go to Step (9)	-
4	<ul style="list-style-type: none"> • Using a DVOM check for continuity between relay terminals 2 and 3 Do you have continuity between them?		Go to Step (3)	Go to Step (5)
5	<ul style="list-style-type: none"> • Key OFF • Disconnect ECM wire harness connector C001 • Using a DVOM check for power between ECM pin 52 and engine ground with the key ON Do you have power?	System battery voltage	Repair the short to power. See wiring harness repair.	Go to Step (6)
6	<ul style="list-style-type: none"> • Replace the power relay Is the replacement complete?		Go to Step (7)	-
7	<ul style="list-style-type: none"> • Remove all test equipment except the DST. • Connect any disconnected components, fuses, etc. • Using the DST clear DTC information from the ECM. • Turn the ignition OFF and wait 30 seconds. • Start the engine and operate the vehicle to full operating temperature • Observe the MIL • Observe engine performance and drivability • After operating the engine within the test parameters of DTC-629 check for any stored codes. Does DTC 629 still re-set?		Go to Step (8)	Go to Step (9)

Step	Action	Value(s)	Yes	No
8	<ul style="list-style-type: none"> Replace the ECM Is the replacement complete?		Go to Step (9)	–
9	<ul style="list-style-type: none"> Remove all test equipment except the DST. Connect any disconnected components, fuses, etc. Using the DST clear DTC information from the ECM. Turn the ignition OFF and wait 30 seconds. Start the engine and operate the vehicle to full operating temperature Observe the MIL Observe engine performance and drivability After operating the engine within the test parameters of DTC-629 check for any stored codes. Does the engine operate normally with no stored codes?		System OK	Go to OBD System Check

DTC 642-External 5 Volt 1 Reference Low (SPN 1079:FMI 4)

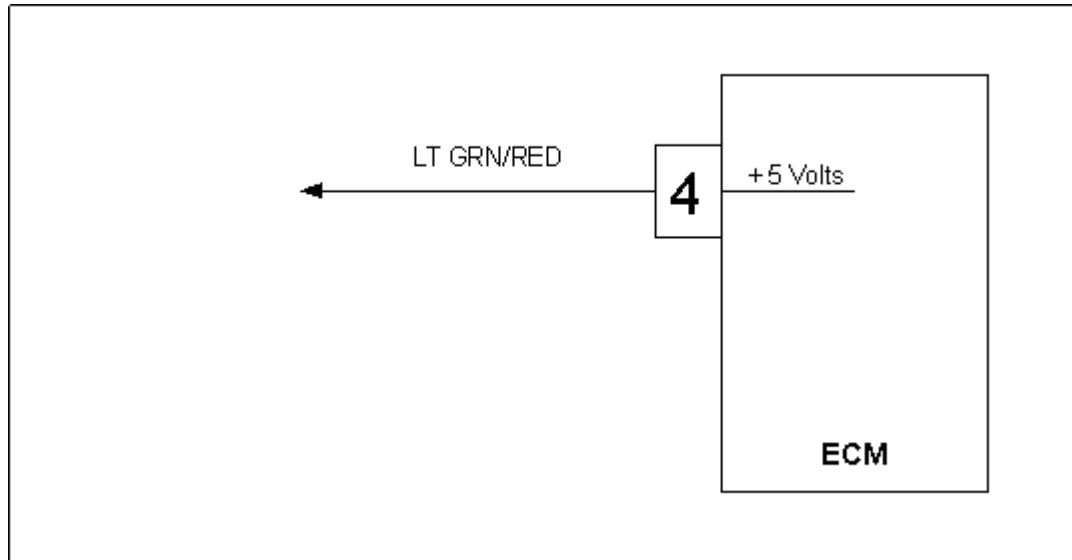

Conditions for Setting the DTC

- External 5 volt reference
- Check Condition-Engine cranking or running
- Fault Condition-5 volt reference voltage lower than 4.60 volts
- MIL-ON during active fault
- Adaptive-Disabled during active fault

Circuit Description

The External 5 volt supply powers many of the sensors and other components of the fuel system. The accuracy of the 5 volt supply is very important to the accuracy of the powered sensors and fuel control by the ECM. The ECM is able to determine if they are overloaded, shorted, or otherwise out of specification by monitoring the 5 volt supply. This fault will set if the 5 volt reference is below 4.60 volts. Adaptive Learn will be disabled during this fault

DTC 642 External 5 Volt 1 Reference Low

Step	Action	Value(s)	Yes	No
1	Did you perform the On-Board (OBD) System Check?	-	Go to Step (2)	Go to OBD System Check Section
2	<ul style="list-style-type: none"> • Key ON, Engine Running • DST (Diagnostic Scan Tool) connected in System Fault Mode Does DST display DTC 642?		Go to Step (3)	Intermittent problem Go to Intermittent section
3	<ul style="list-style-type: none"> • Key OFF • Disconnect ECM connector C001 • Using DVOM check for continuity between ECM 5 volt reference pin 4 and engine ground Do you have continuity?		Go to Step (5)	Go to Step (4)
4	<ul style="list-style-type: none"> • Replace ECM Is the replacement complete?		Go to Step (7)	-
5	<ul style="list-style-type: none"> • While monitoring DVOM for continuity between ECM 5 volt reference and engine ground • Disconnect each sensor (below) one at a time to find the shorted 5 volt reference. When continuity to ground is lost the last sensor disconnected is the area of suspicion. Inspect the 5 volt reference supply wire leads for shorts before replacing the sensor. • TMAP • Electronic Throttle • FPP • Crankshaft Sensor • Camshaft Sensor While disconnecting each sensor one at a time did you lose continuity?		Go to Step (6)	Repair shorted wire harness
6	<ul style="list-style-type: none"> • Replace the last disconnected sensor Is the replacement complete?		Go to Step (7)	-

Step	Action	Value(s)	Yes	No
7	<ul style="list-style-type: none"> • Remove all test equipment except the DST. • Connect any disconnected components, fuses, etc. • Using the DST clear DTC information from the ECM. • Turn the ignition OFF and wait 30 seconds. • Start the engine and operate the vehicle to full operating temperature • Observe the MIL • Observe engine performance and drivability • After operating the engine within the test parameters of DTC-642 check for any stored codes. <p>Does the engine operate normally with no stored codes?</p>		System OK	Go to OBD System Check

DTC 643-External 5 Volt 1 Reference High (SPN 1079:FMI 3)

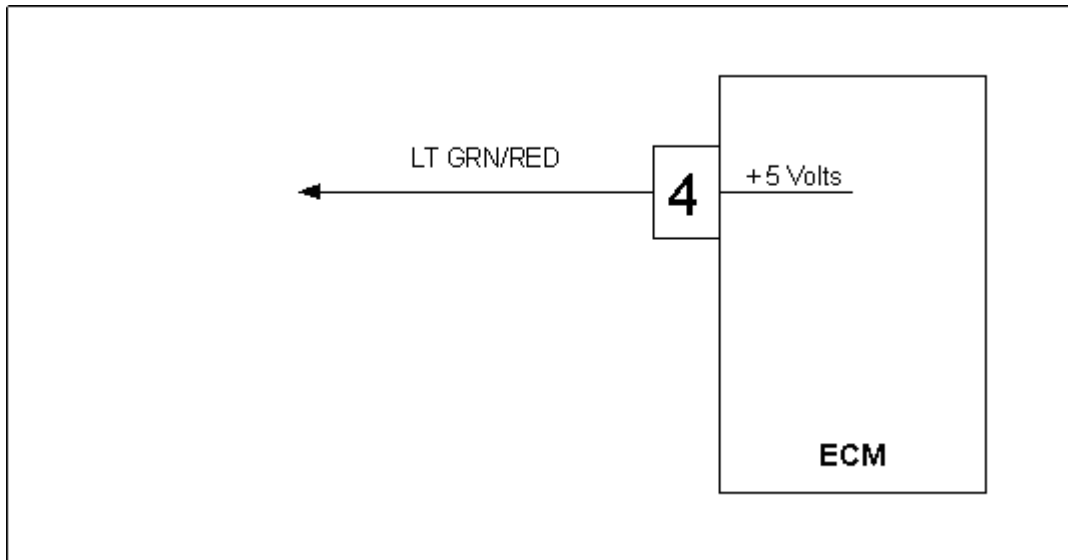

Conditions for Setting the DTC

- External 5 volt reference
- Check Condition-Engine cranking or running
- Fault Condition-5 volt reference higher than 5.40 volts
- MIL-ON during active fault
- Adaptive-Disabled during active fault

Circuit Description

The External 5 volt supply powers many of the sensors and other components in the fuel system. The accuracy of the 5 volt supply is very important to the accuracy of the powered sensors and fuel control by the ECM. The ECM is able to determine if they are overloaded, shorted, or otherwise out of specification by monitoring the 5volt supply. This fault will set if the 5 volt reference is greater than 5.40 volts anytime the engine is cranking or running. Adaptive Learn will be disabled during this fault

DTC 643 External 5 Volt 1 Reference High

Step	Action	Value(s)	Yes	No
1	Did you perform the On-Board (OBD) System Check?	-	Go to Step (2)	Go to OBD System Check Section
2	<ul style="list-style-type: none"> • Key ON, Engine running • DST (Diagnostic Scan Tool) connected in System Data Mode Does DST display DTC 643?		Go to Step (3)	Intermittent problem Go to Intermittent section
3	<ul style="list-style-type: none"> • Check all ECM ground connections • Refer to Engine electrical power and ground distribution. Are the ground connections OK?		Go to Step (4)	Repair the circuit as necessary. Refer to Wiring Repairs in Engine Electrical.
4	<ul style="list-style-type: none"> • Key OFF • Disconnect ECM connector C001 • Key ON • Using DVOM check for Voltage between ECM harness wire pin 4 and engine ground Do you have voltage?		Repair the circuit as necessary. Refer to Wiring Repairs in Engine Electrical.	Go to Step (5)
5	<ul style="list-style-type: none"> • Replace ECM Is the replacement complete?		Go to Step (6)	-
6	<ul style="list-style-type: none"> • Remove all test equipment except the DST. • Connect any disconnected components, fuses, etc. • Using the DST clear DTC information from the ECM. • Turn the ignition OFF and wait 30 seconds. • Start the engine and operate the vehicle to full operating temperature • Observe the MIL • Observe engine performance and drivability • After operating the engine within the test parameters of DTC-643 check for any stored codes. Does the vehicle engine normally with no stored codes?		System OK	Go to OBD System Check

DTC 652-External 5 Volt 2 Reference Low (SPN 1080:FMI 4)

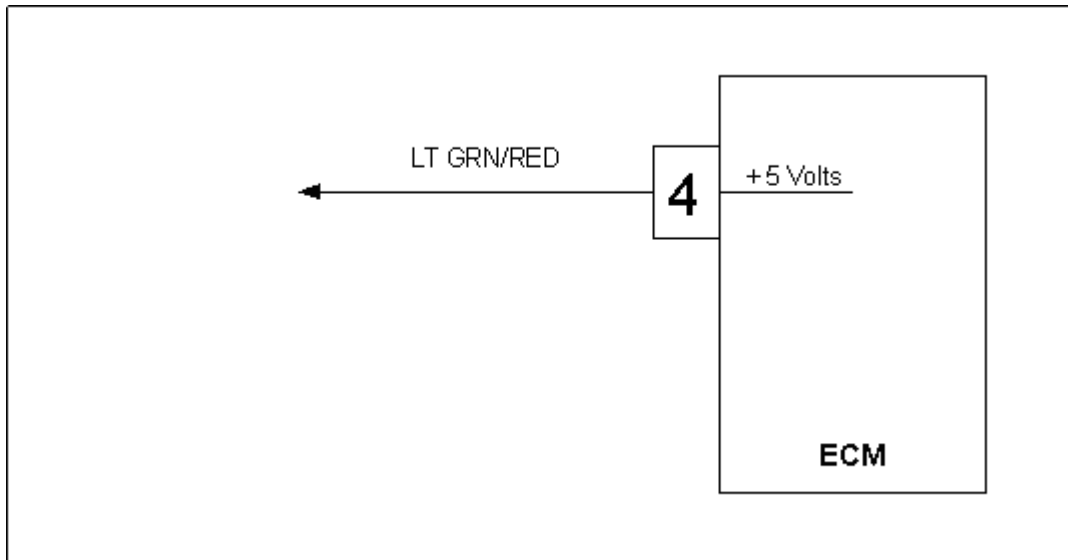

Conditions for Setting the DTC

- External 5 volt reference
- Check Condition-Engine cranking or running
- Fault Condition-5 volt reference voltage lower than 3.00 volts
- MIL-On during active fault
- Adaptive-Disabled during active fault

Circuit Description

The External 5 volt supply is normally dedicated to the FPP sensor 5 volt supply circuit. The accuracy of the 5 volt supply is very important to the accuracy of the FPP sensor circuit. The ECM is able to determine if the circuit is open, shorted, or otherwise out of specification by monitoring this 5 volt supply. This fault will set if the 5 volt reference is below 3.00 volts. Adaptive Learn will be disabled during this fault.

DTC 652 External 5 Volt 2 Reference Low

Step	Action	Value(s)	Yes	No
1	Did you perform the On-Board (OBD) System Check?	-	Go to Step (2)	Go to OBD System Check Section
2	<ul style="list-style-type: none"> • Key ON, Engine Running • DST (Diagnostic Scan Tool) connected in System Fault Mode Does DST display DTC 652?		Go to Step (3)	Intermittent problem Go to Intermittent section
3	<ul style="list-style-type: none"> • Key OFF • Disconnect ECM connector C001 • Using DVOM check for continuity between ECM 5 volt reference pin 4 and engine ground Do you have continuity?		Go to Step (5)	Go to Step (4)
4	<ul style="list-style-type: none"> • Replace ECM Is the replacement complete?		Go to Step (7)	-
5	<ul style="list-style-type: none"> • While monitoring DVOM for continuity between ECM 5 volt reference and engine ground • Disconnect each sensor (below) one at a time to find the shorted 5 volt reference. When continuity to ground is lost the last sensor disconnected is the area of suspicion. Inspect the 5 volt reference supply wire leads for shorts before replacing the sensor. • FPP While disconnecting each sensor one at a time did you lose continuity?		Go to Step (6)	Repair shorted wire harness
6	<ul style="list-style-type: none"> • Replace the last disconnected sensor Is the replacement complete?		Go to step (7)	-
7	<ul style="list-style-type: none"> • Remove all test equipment except the DST. • Connect any disconnected components, fuses, etc. • Using the DST clear DTC information from the ECM. • Turn the ignition OFF and wait 30 seconds. • Start the engine and operate the vehicle to full operating temperature • Observe the MIL • Observe engine performance and drivability • After operating the engine within the test parameters of DTC-652 check for any stored codes. Does the engine operate normally with no stored codes?		System OK	Go to OBD System Check

DTC 653-External 5 Volt 2 Reference High (SPN 1080:FMI 3)

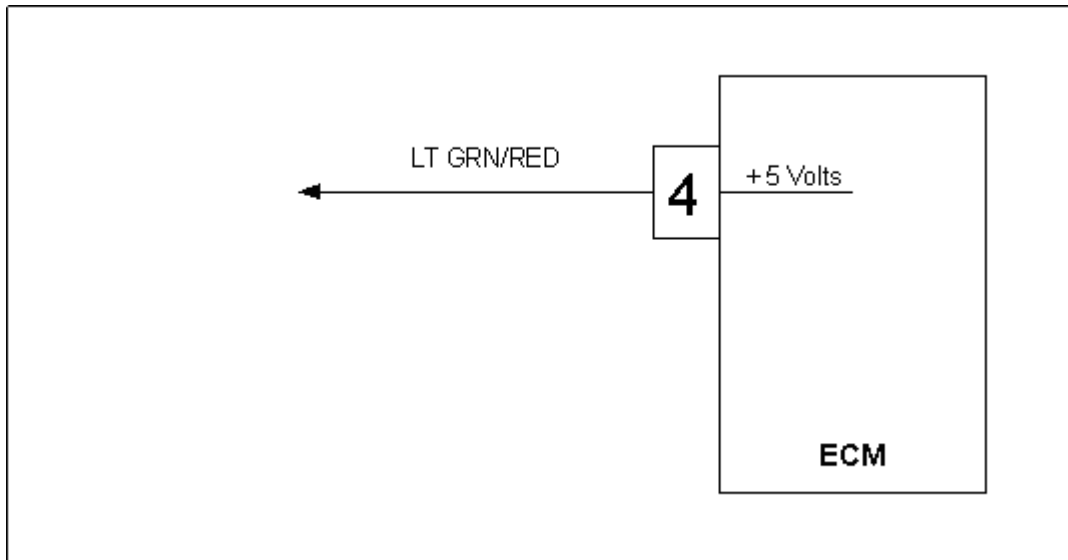

Conditions for Setting the DTC

- External 5 volt reference
- Check Condition-Engine cranking or running
- Fault Condition-5 volt reference higher than 5.40 volts
- MIL-On during active fault
- Adaptive-Disabled during active fault

Circuit Description

The External 5 volt supply is normally dedicated to the FPP sensor 5 volt supply circuit. The accuracy of the 5 volt supply is very important to the accuracy of the FPP sensor circuit. The ECM is able to determine if the circuit is open, shorted, or otherwise out of specification by monitoring this 5 volt supply. This fault will set if the 5 volt reference is above 5.40 volts. Adaptive Learn will be disabled during this fault.

DTC 653 External 5 Volt 2 Reference High

Step	Action	Value(s)	Yes	No
1	Did you perform the On-Board (OBD) System Check?	-	Go to Step (2)	Go to OBD System Check Section
2	<ul style="list-style-type: none"> • Key ON, Engine running • DST (Diagnostic Scan Tool) connected in System Data Mode Does DST display DTC 653?		Go to Step (3)	Intermittent problem Go to Intermittent section
3	<ul style="list-style-type: none"> • Check all ECM ground connections. Refer to Engine electrical power and ground distribution. Are the ground connections Ok?		Go to Step (4)	Repair the circuit as necessary. Refer to Wiring Repairs in Engine Electrical.
4	<ul style="list-style-type: none"> • Key OFF • Disconnect ECM connector C001 • Key ON • Using DVOM check for Voltage between ECM harness wire pin 4 and engine ground Do you have voltage?		Repair the circuit as necessary. Refer to Wiring Repairs in Engine Electrical.	Go to Step (5)
5	<ul style="list-style-type: none"> • Replace ECM Is the replacement complete?		Go to Step (6)	-
6	<ul style="list-style-type: none"> • Remove all test equipment except the DST. • Connect any disconnected components, fuses, etc. • Using the DST clear DTC information from the ECM. • Turn the ignition OFF and wait 30 seconds. • Start the engine and operate the vehicle to full operating temperature • Observe the MIL • Observe engine performance and drivability • After operating the engine within the test parameters of DTC-653 check for any stored codes. Does the vehicle engine normally with no stored codes?		System OK	Go to OBD System Check

DTC 685-Relay Coil Open (SPN 1485:FMI 5)

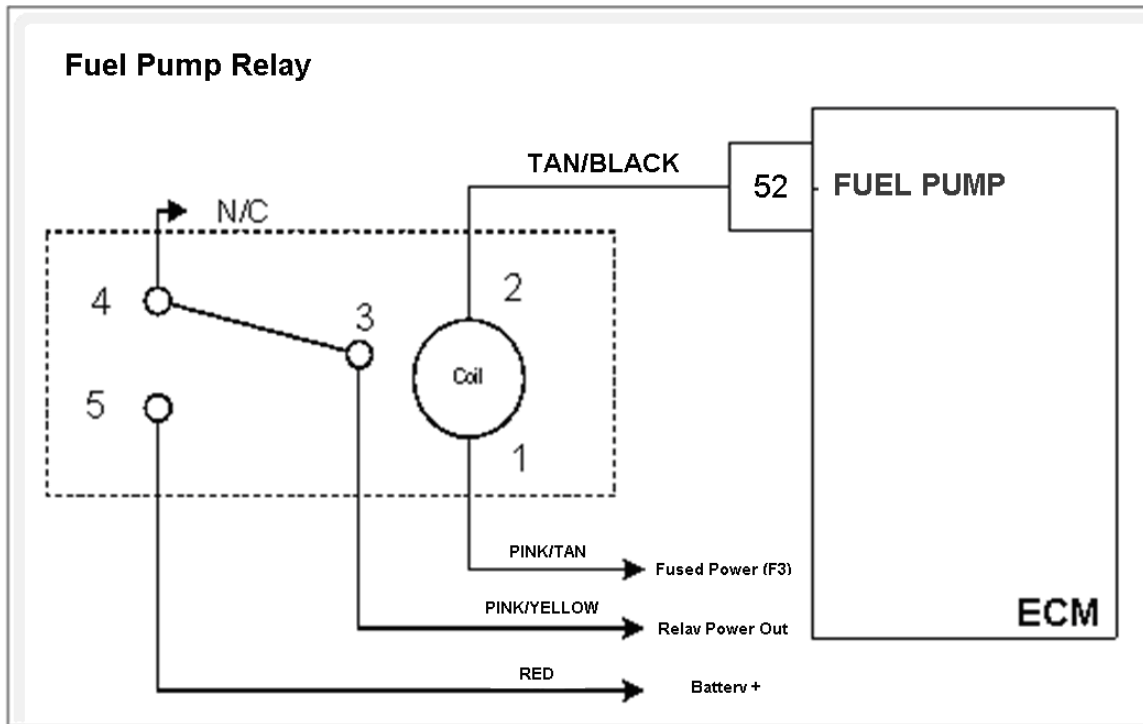

Conditions for Setting the DTC

- Power relay check
- Check Condition-Key ON
- Fault Condition-Relay coil open

Circuit Description

The power relay switches power out to various sensors, actuators and solenoids in the fuel system. This fault will set if the ECM detects an open circuit on the relay control output.

Diagnostic Aid

Relay coil resistance changes with temperature. The following diagnostic charts have steps to measure relay coil resistance values. When checking the resistance values be sure the relay is at a reasonable temperature, between +20 and +100 degrees F.

DTC 685-Relay Coil Open

Step	Action	Value(s)	Yes	No
1	Did you perform the On-Board (OBD) System Check?	-	Go to Step (2)	Go to OBD System Check Section
2	<ul style="list-style-type: none"> • DST connected and in the system data mode • Key OFF • Remove the power relay from the fuse block • Using a DVOM check the resistance of the relay coil between terminals 1 and 2 Is the resistance value less than 100 ohms?		Go to Step (4)	Go to Step (3)
3	<ul style="list-style-type: none"> • Replace the power relay Is the replacement complete?		Go to Step (9)	-
4	<ul style="list-style-type: none"> • Check fuse F2 Is the fuse open?		Replace fuse F2	Go to Step (5)
5	<ul style="list-style-type: none"> • Disconnect ECM connector C001 • Using a DVOM check for continuity between ECM pin 52 and fuse block cavity for relay terminal 2 Do you have continuity?		Go to Step (6)	Repair the open circuit as required. See wiring harness repairs
6	<ul style="list-style-type: none"> • Remove fuse F2 • Using a DVOM check for continuity between fuse block cavity for relay terminal 1 and the power out of the F2 fuse holder Do you have continuity?		Go to Step (7)	Repair the open circuit as required. See wiring harness repairs
7	<ul style="list-style-type: none"> • Check all system fuses. • Check all relay placement positions in fuse block. • Run complete pin to pin checks on chassis wiring to fuel system harness. • See complete fuel system schematic for further details Did you find the problem?		Go to Step (9)	Go to Step (8)

Step	Action	Value(s)	Yes	No
8	<ul style="list-style-type: none"> • Replace the ECM Is the replacement complete?		Go to Step (9)	–
9	<ul style="list-style-type: none"> • Remove all test equipment except the DST. • Connect any disconnected components, fuses, etc. • Using the DST clear DTC information from the ECM. • Turn the ignition OFF and wait 30 seconds. • Start the engine and operate the vehicle to full operating temperature • Observe the MIL • Observe engine performance and drivability • After operating the engine within the test parameters of DTC-685 check for any stored codes. Does the engine operate normally with no stored codes?		System OK	Go to OBD System Check

DTC 686-Relay Control Ground Short (SPN 1485:FMI 4)

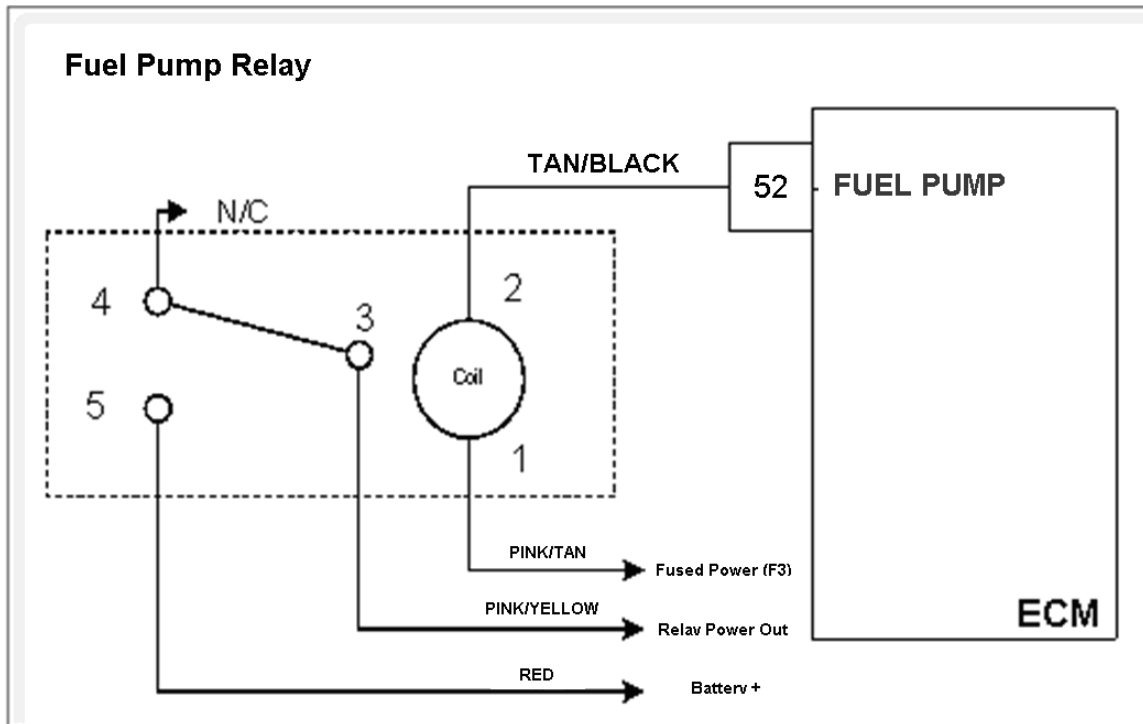

Conditions for Setting the DTC

- Power relay ground control
- Check Condition-Key ON
- Fault Condition-Relay control shorted to ground

Circuit Description

The power relay switches power out to various sensors, actuators and solenoids in the fuel system. This fault will set if the ECM detects a short to ground on the relay control output.

Diagnostic Aid

Relay coil resistance changes with temperature. The following diagnostic charts have steps to measure relay coil resistance values. When checking the resistance values be sure the relay is at a reasonable temperature, between +20 and +100 degrees F.

DTC 686-Relay Control Ground Short

Step	Action	Value(s)	Yes	No
1	Did you perform the On-Board (OBD) System Check?	-	Go to Step (2)	Go to OBD System Check Section
2	<ul style="list-style-type: none"> • Key ON, DST connected in the System Data mode • Clear DTC 686 • Start the engine Does DTC 686 re-set?		Go to Step (4)	Intermittent problem Go to Intermittent section
3	<ul style="list-style-type: none"> • Disconnect ECM connector C001 • Using a DVOM check the resistance value between ECM pin 71 and engine ground Is the resistance less than 60 ohms?		Go to Step (5)	Go to Step (7)
4	<ul style="list-style-type: none"> • Remove the power relay from the fuse block • Using a DVOM check the resistance value again between ECM pin 6 and engine ground Is the resistance less than 60 ohms?		Repair the shorted to ground relay control circuit as necessary. See wiring harness repairs	Go to Step (6)
5	<ul style="list-style-type: none"> • Replace the power relay Is the replacement complete?		Go to Step (8)	–
6	<ul style="list-style-type: none"> • Replace ECM Is the replacement complete?		Go to Step (8)	–
7	<ul style="list-style-type: none"> • Remove all test equipment except the DST. • Connect any disconnected components, fuses, etc. • Using the DST clear DTC information from the ECM. • Turn the ignition OFF and wait 30 seconds. • Start the engine and operate the vehicle to full operating temperature • Observe the MIL • Observe engine performance and drivability • After operating the engine within the test parameters of DTC-686 check for any stored codes. Does the engine operate normally with no stored codes?		System OK	Go to OBD System Check

DTC 687-Relay Coil Short to Power (SPN 1485:FMI 3)

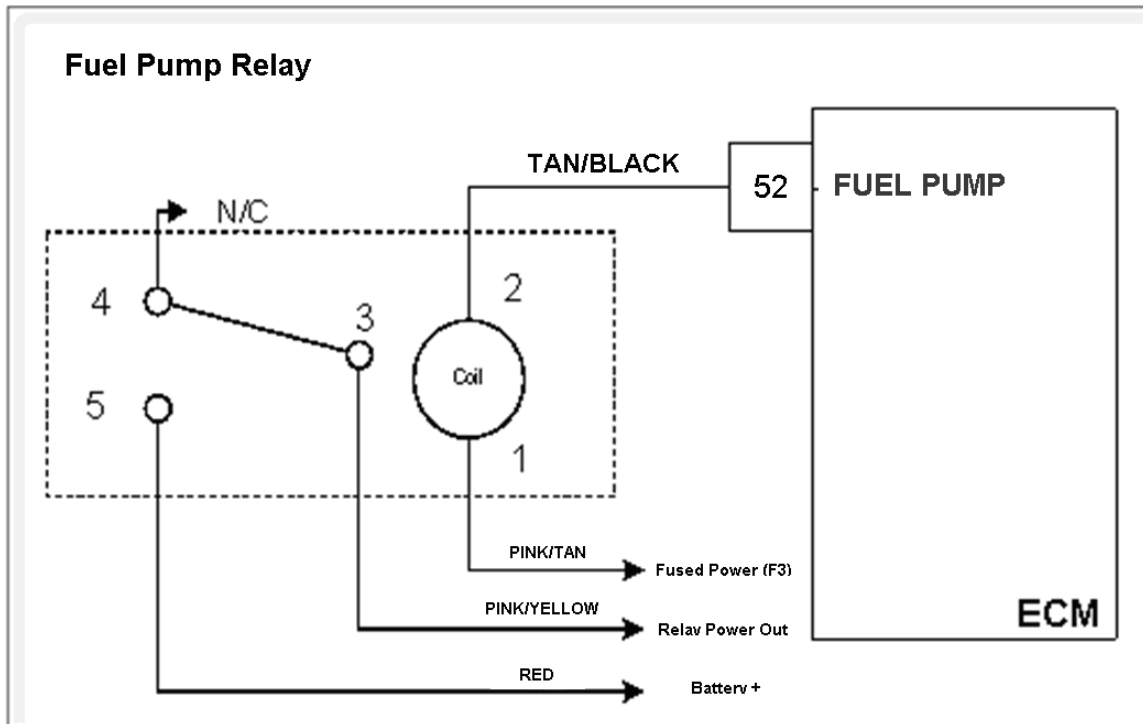

Conditions for Setting the DTC

- Power relay check
- Check Condition-Key ON
- Fault Condition-Relay coil shorted to power

Circuit Description

The power relay switches power out to various sensors, actuators and solenoids in the fuel system. This fault will set if the ECM detects a short circuit to power on the relay control output.

Diagnostic Aid

Relay coil resistance changes with temperature. The following diagnostic charts have steps to measure relay coil resistance values. When checking the resistance values be sure the relay is at a reasonable temperature, between +20 and +100 degrees F.

DTC 687-Relay Coil Short to Power

Step	Action	Value(s)	Yes	No
1	Did you perform the On-Board (OBD) System Check?	-	Go to Step (2)	Go to OBD System Check Section
2	<ul style="list-style-type: none"> • DST connected and in the system data mode • Key OFF • Remove the power relay from the fuse block • Using a DVOM check the resistance of the relay coil between terminals 1 and 2 Is the resistance value less than 60 ohms?		Go to Step (3)	Go to Step (4)
3	<ul style="list-style-type: none"> • Replace the power relay Is the replacement complete?		Go to Step (9)	-
4	<ul style="list-style-type: none"> • Using a DVOM check for continuity between relay terminals 2 and 3 Do you have continuity between them?		Go to Step (3)	Go to Step (5)
5	<ul style="list-style-type: none"> • Key OFF • Disconnect ECM wire harness connector C001 • Using a DVOM check for power between ECM pin 6 and engine ground with the key ON Do you have power?	System battery voltage	Repair the short to power. See wiring harness repair.	Go to Step (6)
6	<ul style="list-style-type: none"> • Replace the power relay Is the replacement complete?		Go to Step (7)	-
7	<ul style="list-style-type: none"> • Remove all test equipment except the DST. • Connect any disconnected components, fuses, etc. • Using the DST clear DTC information from the ECM. • Turn the ignition OFF and wait 30 seconds. • Start the engine and operate the vehicle to full operating temperature • Observe the MIL • Observe engine performance and drivability • After operating the engine within the test parameters of DTC-687 check for any stored codes. Does DTC 687 still re-set?		Go to Step (8)	Go to Step (9)

Step	Action	Value(s)	Yes	No
8	<ul style="list-style-type: none"> Replace the ECM Is the replacement complete?		Go to Step (9)	–
9	<ul style="list-style-type: none"> Remove all test equipment except the DST. Connect any disconnected components, fuses, etc. Using the DST clear DTC information from the ECM. Turn the ignition OFF and wait 30 seconds. Start the engine and operate the vehicle to full operating temperature Observe the MIL Observe engine performance and drivability After operating the engine within the test parameters of DTC-687 check for any stored codes. Does the engine operate normally with no stored codes?		System OK	Go to OBD System Check

DTC 1111-Fuel Rev Limit (SPN 515:FMI 16)

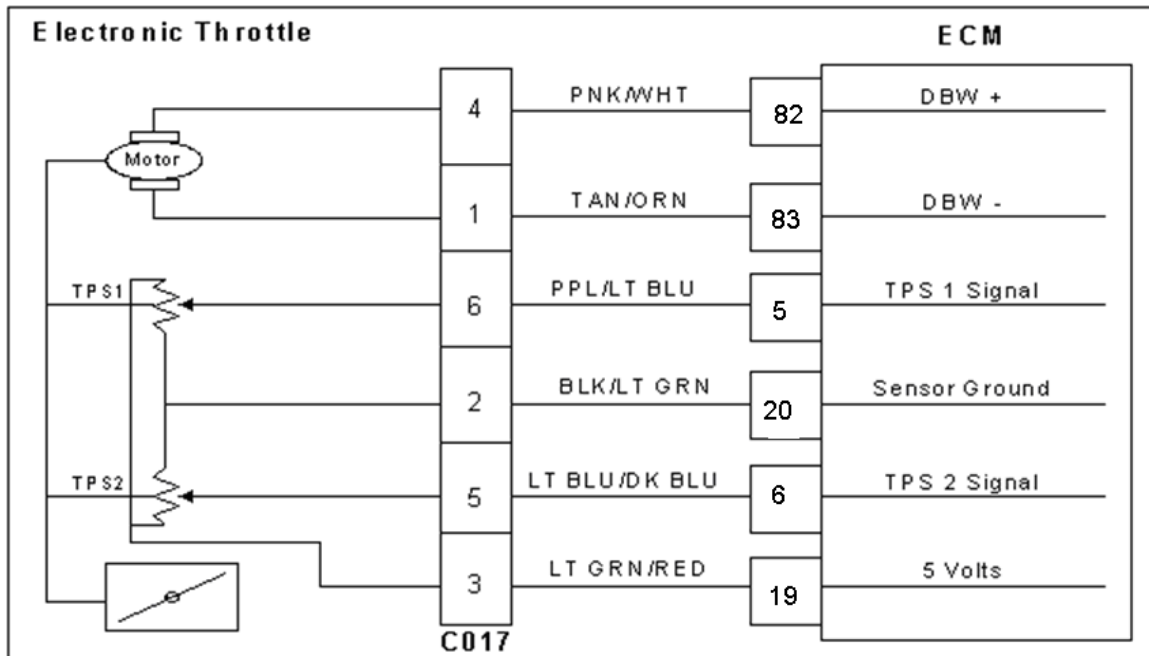

Conditions for Setting the DTC

- Fuel Rev Limit
- Check Condition-Engine Running
- Fault Condition-Engine rpm greater than set limit
- MIL-ON during active fault

Circuit Description

This fault will set anytime the engine rpm exceeds the specified speed settings in the calibration. This is generally set at 3000 rpms. The MIL command is ON during this active fault

Diagnostic Aid

Always check for other stored DTC codes before using the following DTC chart for this code set. Repair any existing codes starting with the lowest numerical code first.

DTC 1111-Fuel Rev Limit

Step	Action	Value(s)	Yes	No
1	Did you perform the On-Board (OBD) System Check?	-	Go to Step (2)	Go to OBD System Check Section
2	<ul style="list-style-type: none"> • Key ON, Engine OFF • DST in Active Fault Mode Are any other DTC codes present with DTC 1111?		Go to Step (3)	Go to Step (4)
3	<ul style="list-style-type: none"> • Diagnose and repair any other DTC codes before proceeding with this chart. Have any other DTC codes been diagnosed and repaired?		Go to Step (4)	-
4	<ul style="list-style-type: none"> • Check the service part Number on the ECM to ensure correct calibration is in use Is the service part Number Correct?		Go to Step (6)	Go to Step 5
5	<ul style="list-style-type: none"> • Replace ECM with the correct service part number Is the replacement complete?		Go to Step (9)	-
6	<ul style="list-style-type: none"> • Check the mechanical operation of the throttle Is the mechanical operation of the throttle OK?		Go to Step (8)	Go to Step (7)
7	<ul style="list-style-type: none"> • Correct mechanical operation of the throttle. Refer to Engine & Component section Has the mechanical operation of the throttle been corrected?		Go to Step (9)	-
8	<ul style="list-style-type: none"> • Check engine for large manifold vacuum leaks. Refer to Fuel Systems symptom diagnostics Did you find and correct the vacuum leak?		Go to Step (9)	Go to OBD System Check Section
9	<ul style="list-style-type: none"> • Remove all test equipment except the DST. • Connect any disconnected components, fuses, etc. • Using the DST clear DTC information from the ECM. • Turn the ignition OFF and wait 30 seconds. • Start the engine and operate the vehicle to full operating temperature • Observe the MIL • Observe engine performance and drivability • After operating the engine within the test parameters of DTC-1111 check for any stored codes. Does the engine operate normally with no stored codes?		System OK	Go to OBD System Check

DTC 1112-Spark Rev Limit (SPN 515: FMI 0)

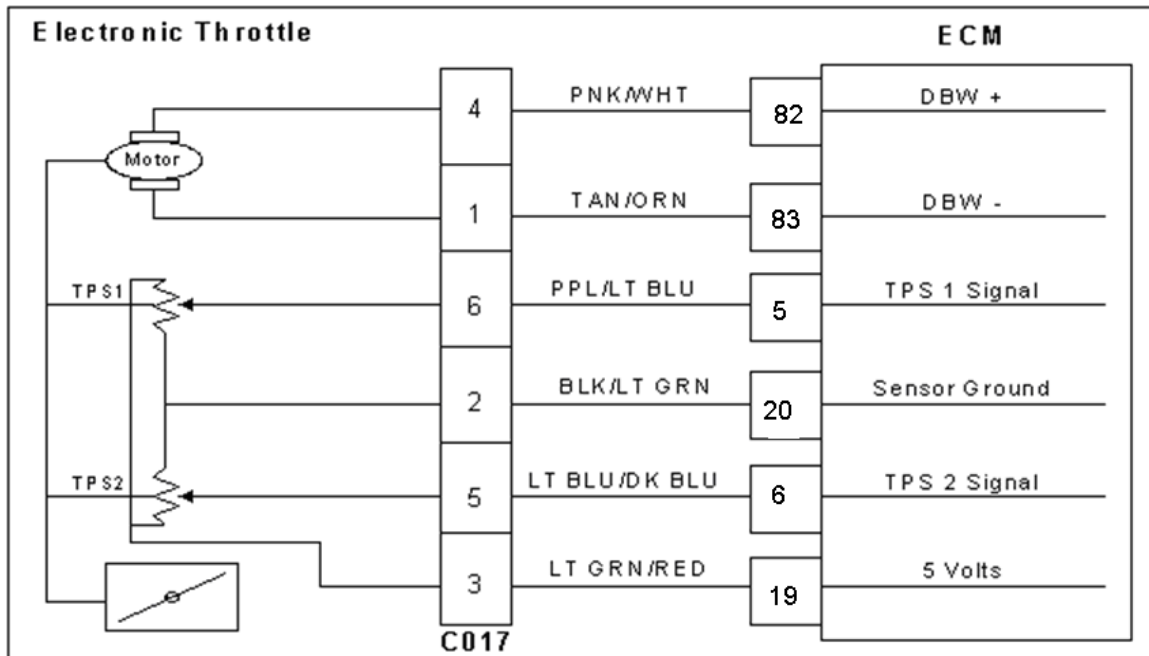

Conditions for Setting the DTC

- Spark Rev Limit
- Check Condition-Engine running
- Fault Condition-Engine rpm greater than set limit
- MIL-ON during active fault
- Engine Shut Down

Circuit description

This fault will set anytime the engine rpm exceeds the specified speed settings installed in the calibration. This is generally set at 3200 rpms. The MIL command is ON during this active fault and the engine will shut down.

Diagnostic Aid

Always check for other stored DTC codes before using the following DTC chart for this code set. Repair any existing codes starting with the lowest numerical code first.

DTC 1112-Spark Rev Limit

Step	Action	Value(s)	Yes	No
1	Did you perform the On-Board (OBD) System Check?	-	Go to Step (2)	Go to OBD System Check Section
2	<ul style="list-style-type: none"> • Key ON, Engine OFF • DST connected Are any other DTC codes present with DTC 1112?		Go to Step (3)	Go to Step (4)
3	<ul style="list-style-type: none"> • Diagnose any other DTC codes before proceeding with this chart. Have any other DTC codes been diagnosed and repaired?		Go to Step (4)	-
4	<ul style="list-style-type: none"> • Check the service part number on the ECM to ensure correct calibration is in use Is the service part number correct?		Go to Step (6)	Go to Step 5
5	<ul style="list-style-type: none"> • Replace ECM with correct service part number Is the replacement complete?		Go to Step (9)	-
6	<ul style="list-style-type: none"> • Check the mechanical operation of the throttle Is the mechanical operation of the throttle OK?		Go to Step (8)	Go to Step (7)
7	<ul style="list-style-type: none"> • Correct mechanical operation of the throttle. Refer to Engine & Component section Has the mechanical operation of the throttle been corrected?		Go to Step (9)	-
8	<ul style="list-style-type: none"> • Check engine for large manifold vacuum leaks. Refer to Fuel Systems Section Symptom Diagnostics Did you find and correct the vacuum leak?		Go to Step (9)	Go to OBD System Check Section
9	<ul style="list-style-type: none"> • Remove all test equipment except the DST. • Connect any disconnected components, fuses, etc. • Using the DST clear DTC information from the ECM. • Turn the ignition OFF and wait 30 seconds. • Start the engine and operate the vehicle to full operating temperature • Observe the MIL • Observe engine performance and drivability • After operating the engine within the test parameters of DTC-1112 check for any stored codes. Does the engine operate normally with no stored codes?		System OK	Go to OBD System Check

DTC 1151-Closed Loop Multiplier High LPG (SPN 520206:FMI 0)

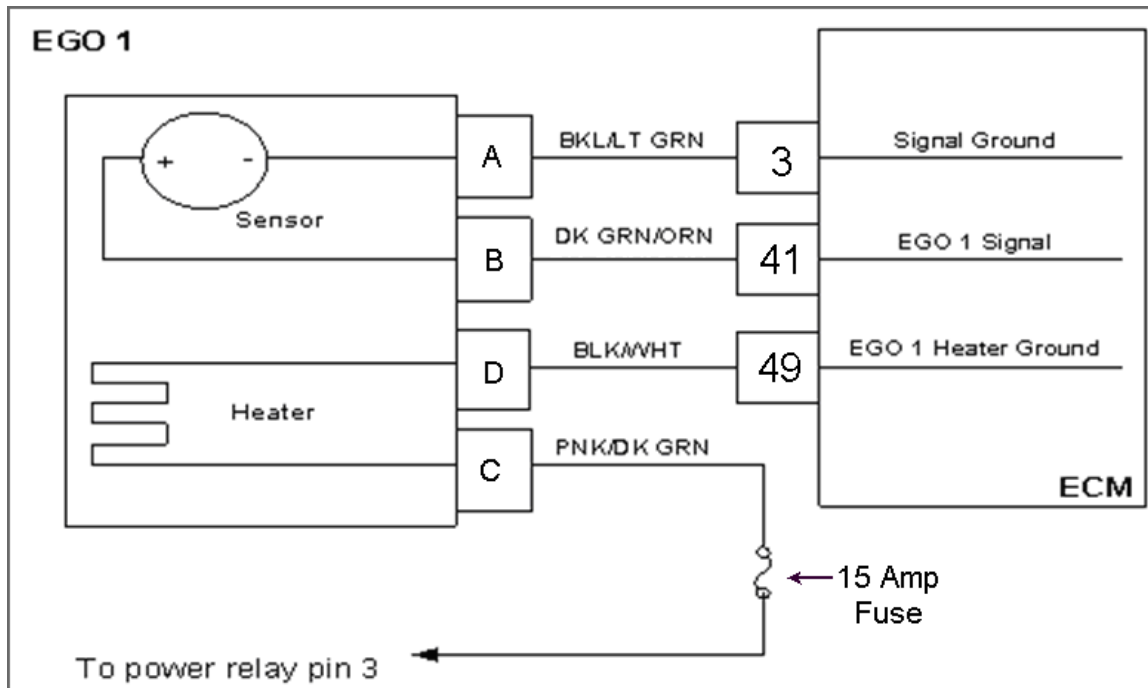

Conditions for Setting the DTC

- Heated Oxygen Sensor
- Check Condition-Engine running
- Fault Condition-Closed Loop multiplier out of range (greater than 35%)
- MIL-ON

Circuit description

The EGO sensor is used to determine if the fuel flow to the engine is correct by measuring the oxygen content in the exhaust gas. The ECM uses this information to correct the fuel flow with the Closed Loop multiplier and the adaptive multiplier. This fault sets if the Closed Loop multiplier exceeds the limits of normal operation and cannot correctly modify the fuel flow within its limits.

Diagnostic Aid

Oxygen Sensor Wire Heated Oxygen sensor wires may be mis-routed and contacting the exhaust manifold.

Vacuum Leaks Large vacuum leaks and crankcase leaks can cause a lean exhaust condition at especially at light load.

Fuel Mixer System can be lean due to faulty EPR (Electronic Pressure Regulator) or faulty fuel mixer.

Fuel Pressure Low fuel pressure, faulty fuel regulator or contaminated fuel filter can cause fuel the system to run lean

Exhaust Leaks If there is an exhaust leak, outside air can be pulled into the exhaust and past the O₂ sensor causing a false lean condition.

Fuel Quality Contaminated or spoiled fuel can cause the fuel system to be lean.

Ground Problem ECM grounds must be clean, tight and in the proper location.

DTC 1151-Closed Loop High LPG

Step	Action	Value(s)	Yes	No
1	<ul style="list-style-type: none"> Perform the On-Board (OBD) System Check? Are any other DTCs present?		Go to Step (3)	Go to Step (2)
2	Visually and physically check the following items: <ul style="list-style-type: none"> The air intake duct for being collapsed or restricted The air filter for being plugged System power fuses are good and in the proper location The EGO 1 sensor installed securely and the wire leads not contacting the exhaust manifold or ignition wires ECM grounds must be clean and tight. Refer to Engine Electrical Power and Ground Distribution Fuel System Diagnostics. Refer to Fuel System Diagnostics Was a repair made?		Go to Step (9)	Go to Step (4)
3	<ul style="list-style-type: none"> Diagnose any other DTC codes before proceeding with this chart. Always repair existing codes starting with the lowest numerical code set first. Have any other DTC codes been detected, diagnosed and repaired?		Go to Step (9)	Go to step (4)
4	<ul style="list-style-type: none"> Disconnect EGO1 connector C005 Using a DVOM check for voltage between EGO 1 connector pin B and engine ground Key ON (CHECK MUST BE MADE WITHIN 30 SECONDS OR BEFORE POWER RELAY SHUTS DOWN) Do you have voltage?	System voltage	Go to Step (5)	Repair the open EGO power circuit as necessary. Refer to Wiring Repairs in Engine Electrical.
5	<ul style="list-style-type: none"> Key OFF Disconnect EGO 1 sensor wire harness connector C005 Disconnect ECM wire harness connector C001 Key ON Using a high impedance DVOM check for continuity between EGO 1 connector signal pin A and engine ground Do you have continuity?		Repair the shorted circuit as necessary. Refer to Wiring Repairs in Engine Electrical.	Go to Step (6)

Step	Action	Value(s)	Yes	No
6	<ul style="list-style-type: none"> Using a high impedance DVOM check for continuity between EGO 1 connector signal ground pin C and EGO 1 signal pin A Do you have continuity?		Repair the shorted circuit as necessary. Refer to Wiring Repairs in Engine Electrical.	Go to Step (7)
7	<ul style="list-style-type: none"> Using a high impedance DVOM check for continuity between EGO 1 heater ground pin D and ECM pin 49 Do you have continuity?		Go to step (8)	Repair the open EGO heater ground
8	<ul style="list-style-type: none"> Replace EGO 1 sensor Is the replacement complete?		Go to Step (9)	-
9	<ul style="list-style-type: none"> Remove all test equipment except the DST. Connect any disconnected components, fuses, etc. Using the DST clear DTC information from the ECM. Turn the ignition OFF and wait 30 seconds. Start the engine and operate the vehicle to full operating temperature Observe the MIL Observe engine performance and drivability After operating the engine within the test parameters of DTC-1151 check for any stored codes. Does the engine operate normally with no stored codes?		System OK	Go to OBD System Check

DTC 1152-Closed Loop Multiplier Low LPG (SPN 520206:FMI 1)

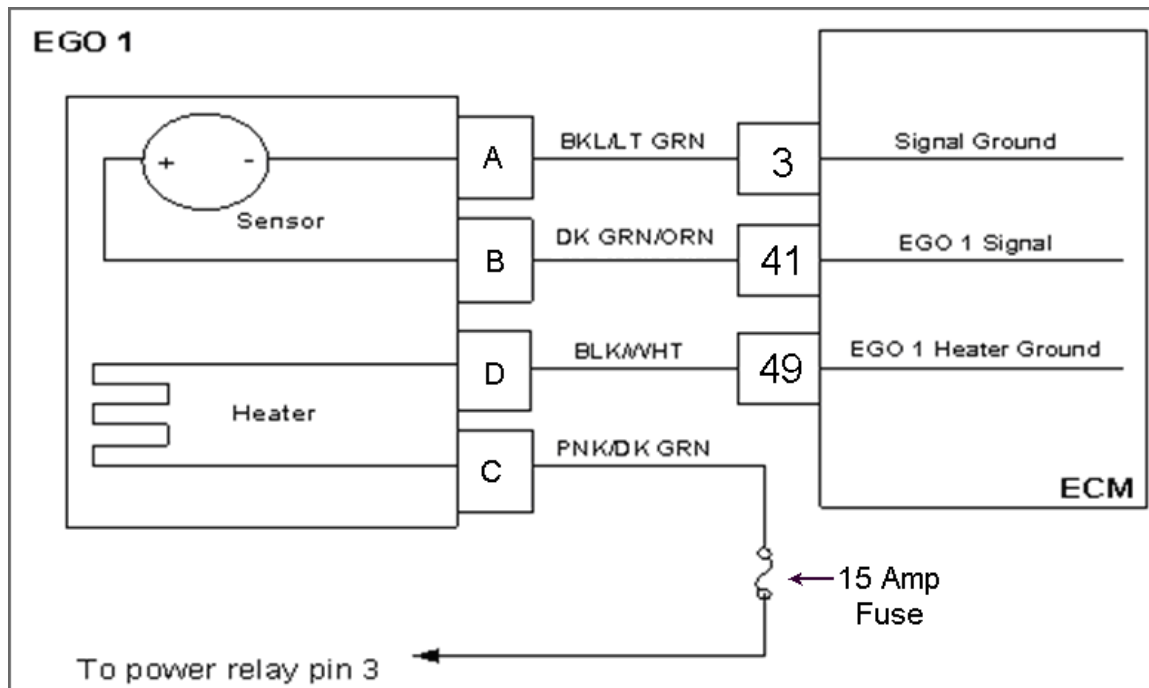

Conditions for Setting the DTC

- Heated Oxygen Sensor
- Functional Fault-Closed Loop multiplier out of range (at limit of -35%)
- MIL Disabled

Circuit Description

The EGO 1 sensor is used to determine if the fuel flow to the engine is correct by measuring the oxygen content in the exhaust gas. The ECM uses this information to correct the fuel flow with the Closed Loop multiplier and the adaptive multiplier. This fault sets if the Closed Loop multiplier exceeds the limits of normal operation. When the multiplier cannot correctly modify the fuel flow within its limits, it is limited at -35%.

Diagnostic Aid

Fuel System High secondary fuel pressure will cause the system to run rich. A worn fuel mixer, faulty EPR (Electronic Pressure Regulator) may also cause the system to run rich.

Fuel Quality A drastic variation in fuel quality (very high butane content) may cause the fuel system to run rich. Be sure that the specified HD-5 or HD-10 motor fuel grade LPG is used.

Air Filter A plugged, damaged or modified air filter may cause the system to run rich.

DTC 1152 –Closed Loop Low LPG

Step	Action	Value(s)	Yes	No
1	<ul style="list-style-type: none"> Perform the On-Board (OBD) System Check? Are any other DTCs present?		Go to Step (3)	Go to Step (2)
2	Visually and physically check the following items: <ul style="list-style-type: none"> The air intake duct for being collapsed or restricted The air filter for being plugged The EGO sensor installed securely and the wire leads not damaged contacting the secondary ignition wires ECM grounds for being clean and tight. Run the fuel system diagnostic checks Was a repair made?		Go to Step (6)	Go to Step (4)
3	<ul style="list-style-type: none"> Diagnose any other DTC codes before proceeding with this chart. Have any other DTC codes been detected, diagnosed and repaired?		Go to Step (6)	Go to Step (4)
4	<ul style="list-style-type: none"> Key OFF Disconnect EGO sensor wire harness connector Disconnect ECM wire harness connector Key ON Using a DVOM check for voltage at the EGO 1 connector C005 signal pin C and engine ground Do you have voltage?		Repair the circuit short to voltage as necessary. Refer to wiring harness repair.	Go to Step (5)
5	<ul style="list-style-type: none"> Replace EGO sensor Is the replacement complete?		Go to Step (6)	-
6	<ul style="list-style-type: none"> Remove all test equipment except the DST. Connect any disconnected components, fuses, etc. Using the DST clear DTC information from the ECM. Turn the ignition OFF and wait 30 seconds. Start the engine and operate the vehicle to full operating temperature Observe the MIL Observe engine performance and drivability After operating the engine within the test parameters of DTC-1152 check for any stored codes. Does the engine operate normally with no stored codes?		System OK	Go to OBD System Check

DTC 1155-Closed Loop Multiplier High Gasoline (SPN 520204 :FMI 0)

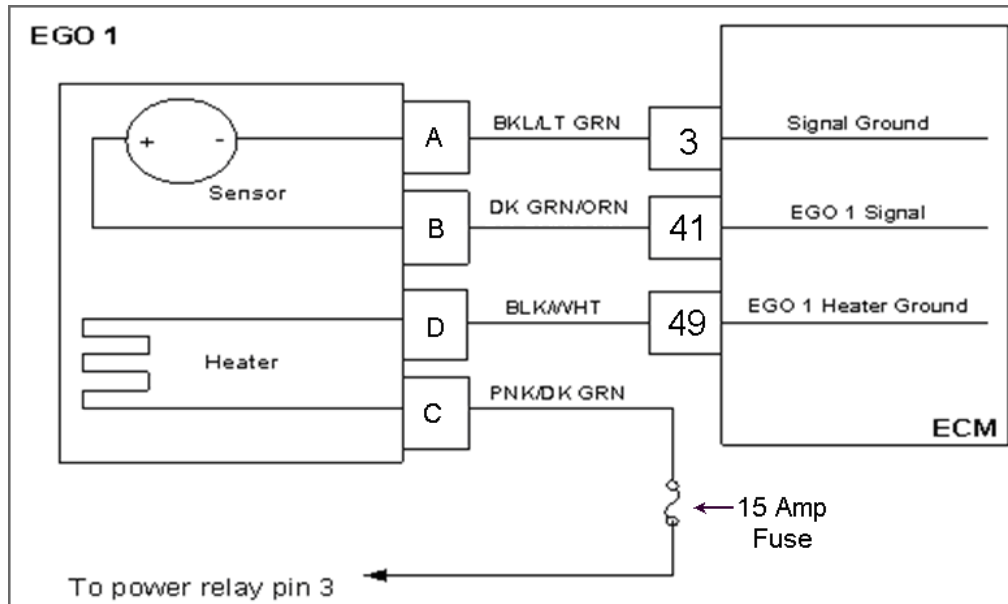

Conditions for Setting the DTC

- Heated Oxygen Sensor
- Check Condition-Engine running
- Fault Condition-Closed Loop multiplier out of range (greater than 35%)
- MIL-ON

Circuit description

The EGO sensor is used to determine if the fuel flow to the engine is correct by measuring the oxygen content in the exhaust gas. The ECM uses this information to correct the fuel flow with the Closed Loop multiplier and the adaptive multiplier. This fault sets if the Closed Loop multiplier exceeds the limits of normal operation and cannot correctly modify the fuel flow within its limits.

Diagnostic Aid

Oxygen Sensor Wire Heated Oxygen sensor wires may be mis-routed and contacting the exhaust manifold.

Vacuum Leaks Large vacuum leaks and crankcase leaks can cause a lean exhaust condition at especially at light load.

Fuel Mixer System can be lean due to faulty EPR (Electronic Pressure Regulator) or faulty fuel mixer.

Fuel Pressure Low fuel pressure, faulty fuel regulator or contaminated fuel filter can cause the system to run lean

Exhaust Leaks If there is an exhaust leak, outside air can be pulled into the exhaust and past the O₂ sensor causing a false lean condition.

Fuel Quality Contaminated or spoiled fuel can cause the fuel system to be lean.

Ground Problem ECM grounds must be clean, tight and in the proper location.

DTC 1155-Closed Loop Multiplier High Gasoline

Step	Action	Value(s)	Yes	No
1	<ul style="list-style-type: none"> • Perform the On-Board (OBD) System Check? Are any other DTCs present?		Go to Step (3)	Go to Step (2)
2	Visually and physically check the following items: <ul style="list-style-type: none"> • The air intake duct for being collapsed or restricted • The air filter for being plugged • System power fuses are good and in the proper location • The EGO 1 sensor installed securely and the wire leads not contacting the exhaust manifold or ignition wires • ECM grounds must be clean and tight. Refer to Engine Electrical Power and Ground Distribution • Fuel System Diagnostics. Refer to Fuel System Diagnostics Was a repair made?		Go to Step (9)	Go to Step (4)
3	<ul style="list-style-type: none"> • Diagnose any other DTC codes before proceeding with this chart. Always repair existing codes starting with the lowest numerical code set first. Have any other DTC codes been detected, diagnosed and repaired?		Go to Step (9)	Go to step (4)
4	<ul style="list-style-type: none"> • Disconnect EGO1 connector C005 • Using a DVOM check for voltage between EGO 1 connector pin B and engine ground • Key ON (CHECK MUST BE MADE WITHIN 30 SECONDS OR BEFORE POWER RELAY SHUTS DOWN) Do you have voltage?	System voltage	Go to Step (5)	Repair the open EGO power circuit as necessary. Refer to Wiring Repairs in Engine Electrical.
5	<ul style="list-style-type: none"> • Key OFF • Disconnect EGO 1 sensor wire harness connector C005 • Disconnect ECM wire harness connector C001 • Key ON • Using a high impedance DVOM check for continuity between EGO 1 connector signal pin A and engine ground Do you have continuity?		Repair the shorted circuit as necessary. Refer to Wiring Repairs in Engine Electrical.	Go to Step (6)

Step	Action	Value(s)	Yes	No
6	<ul style="list-style-type: none"> Using a high impedance DVOM check for continuity between EGO 1 connector signal ground pin C and EGO 1 signal pin A Do you have continuity?		Repair the shorted circuit as necessary. Refer to Wiring Repairs in Engine Electrical.	Go to Step (7)
7	<ul style="list-style-type: none"> Using a high impedance DVOM check for continuity between EGO 1 heater ground pin D and ECM pin 49 Do you have continuity?		Go to step (8)	Repair the open EGO heater ground
8	<ul style="list-style-type: none"> Replace EGO 1 sensor Is the replacement complete?		Go to Step (9)	-
9	<ul style="list-style-type: none"> Remove all test equipment except the DST. Connect any disconnected components, fuses, etc. Using the DST clear DTC information from the ECM. Turn the ignition OFF and wait 30 seconds. Start the engine and operate the vehicle to full operating temperature Observe the MIL Observe engine performance and drivability After operating the engine within the test parameters of DTC-1151 check for any stored codes. Does the engine operate normally with no stored codes?		System OK	Go to OBD System Check

DTC 1156-Adaptive Learn Low (Gasoline) (SPN 520204:FMI 1)

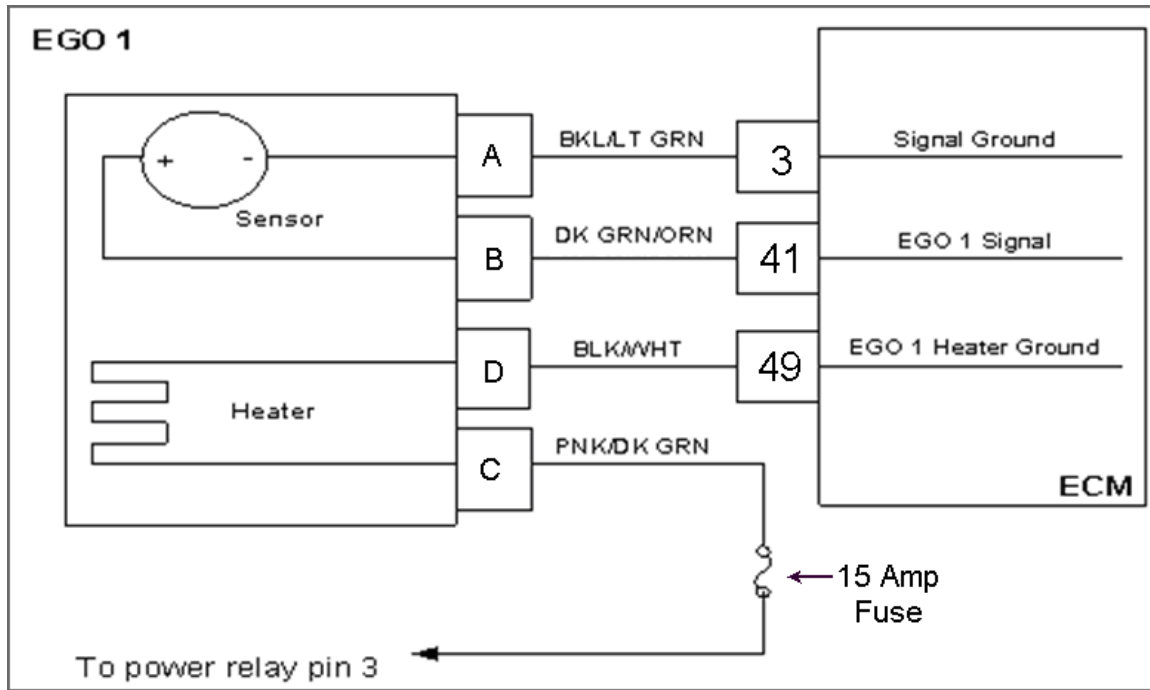

Conditions for Setting the DTC

- Heated Oxygen Sensor
- Check Condition-Engine running
- Fault Condition-Adaptive multiplier out of range greater than -30%
- MIL-ON

Circuit Description

The EGO1 sensor is used to determine if the fuel flow to the engine is correct by measuring the oxygen content in the exhaust gas. The ECM uses this information to correct the fuel flow with the Closed Loop multiplier and Adaptive multiplier. This fault will set if the adaptive multiplier exceeds the limits of normal operation. Always run the fuel system diagnostics before using the following diagnostic chart.

Diagnostic Aid

Fuel System High fuel pressure will cause the system to run rich. Fuel pressure is controlled by the ECM using a ground side driver. If the fuel pump is turned on all the time the fuel pressure will increase. Open or leaking injector will cause a rich condition.

Fuel Quality A drastic variation in fuel quality may cause the fuel system to run rich.

Air Filter A plugged, damaged or modified air filter may cause the system to run rich.

DTC 1156-Adaptive Learn Low (Gasoline)

Step	Action	Value(s)	Yes	No
1	<ul style="list-style-type: none"> Perform the On-Board (OBD) System Check? Are any other DTCs present?		Go to Step (3)	Go to Step (2)
2	Visually and physically check the following items: <ul style="list-style-type: none"> The air intake duct for being collapsed or restricted The air filter for being plugged The EGO sensor is installed securely and the wire leads not damaged or contacting the secondary ignition wires ECM grounds for being clean and tight. Fuel system diagnostic checks Was a repair made?		Go to Step (6)	Go to Step (4)
3	<ul style="list-style-type: none"> Diagnose any other DTC codes before proceeding with this chart. Have any other DTC codes been detected, diagnosed and repaired?		Go to Step (6)	Go to Step (4)
4	<ul style="list-style-type: none"> Key OFF Disconnect EGO sensor wire harness connector C005 Disconnect ECM wire harness connector C001 Key ON Using a DVOM check for voltage at EGO 1 connector signal pin A and engine ground Do you have voltage?		Repair the circuit as necessary. Refer to Wiring Repairs in Engine Electrical.	Go to Step (5)
5	<ul style="list-style-type: none"> Replace EGO sensor Is the replacement complete?		Go to Step (6)	-
6	<ul style="list-style-type: none"> Remove all test equipment except the DST. Connect any disconnected components, fuses, etc. Using the DST clear DTC information from the ECM. Turn the ignition OFF and wait 30 seconds. Start the engine and operate the vehicle to full operating temperature Observe the MIL Observe engine performance and drivability After operating the engine within the test parameters of DTC-1162 check for any stored codes. Does the engine operate normally with no stored codes?		System OK	Go to OBD System Check

DTC 1161-Adaptive Learn High LPG (SPN 520202:FMI 0)

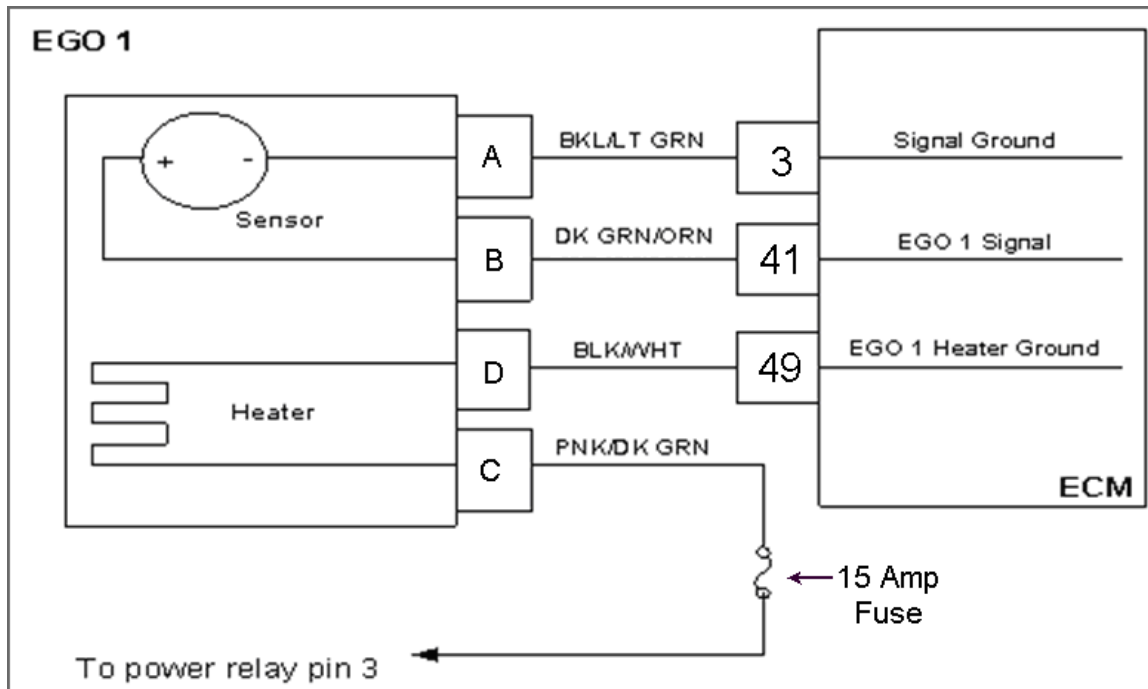

Conditions for Setting the DTC

- Heated Oxygen Sensor
- Check Condition-Engine Running
- Fault Condition-Adaptive multiplier out of range greater than 30%
- MIL-ON

Circuit Description

The EGO 1 sensor is used to determine if the fuel flow to the engine is correct by measuring the oxygen content in the exhaust gas. The ECM uses this information to correct the fuel flow with the Closed Loop multiplier and Adaptive multiplier. This fault will set if the adaptive multiplier exceeds the limits of normal operation. Always run the fuel system diagnostic checks before using the following diagnostic chat.

Diagnostic Aid

Oxygen Sensor Wire Heated Oxygen sensor wires may be mis-routed and contacting the exhaust manifold.

Vacuum Leaks Large vacuum leaks and crankcase leaks can cause a lean exhaust condition at especially at light load.

Fuel Mixer System can be lean due to faulty EPR (Electronic Pressure Regulator) or faulty fuel mixer.

Fuel Pressure Low fuel pressure, faulty fuel regulator or contaminated fuel filter can cause fuel the system to run lean

Exhaust Leaks If there is an exhaust leak, outside air can be pulled into the exhaust and past the O2 sensor causing a false lean condition.

Fuel Quality Contaminated or spoiled fuel can cause the fuel system to be lean.

Ground Problem ECM grounds must be clean, tight and in the proper location.

DTC 1161 Adaptive Learn High LPG

Step	Action	Value(s)	Yes	No
1	<ul style="list-style-type: none"> • Perform the On-Board (OBD) System Check? Are any other DTCs present?		Go to Step (3)	Go to Step (2)
2	Visually and physically check the following items: <ul style="list-style-type: none"> • The air intake duct for being collapsed or restricted • The air filter for being plugged • System power fuses are good and in the proper location • The EGO 1 sensor installed securely and the wire leads not contacting the exhaust manifold or ignition wires • ECM grounds must be clean and tight. Refer to Engine Electrical Power and Ground Distribution • Fuel System Diagnostics. Refer to Fuel System Diagnostics Was a repair made?		Go to Step (9)	Go to Step (4)
3	<ul style="list-style-type: none"> • Diagnose any other DTC codes before proceeding with this chart. Always repair existing codes starting with the lowest numerical code set first. Have any other DTC codes been detected, diagnosed and repaired?		Go to Step (9)	Go to Step (4)
4	<ul style="list-style-type: none"> • Disconnect EGO1 connector C005 • Using a DVOM check for voltage between EGO 1 connector pin B and engine ground • Key ON (CHECK MUST BE MADE WITHIN 30 SECONDS OR BEFORE POWER RELAY SHUTS DOWN) Do you have voltage?	System voltage	Go to Step (5)	Repair the open EGO power circuit as necessary. Refer to Wiring Repairs in Engine Electrical.
5	<ul style="list-style-type: none"> • Key OFF • Disconnect EGO 1 sensor wire harness connector C005 • Disconnect ECM wire harness connector C001 • Key ON • Using a high impedance DVOM check for continuity between EGO 1 connector signal pin A and engine ground Do you have continuity?		Repair the shorted circuit as necessary. Refer to Wiring Repairs in Engine Electrical.	Go to Step (6)

Step	Action	Value(s)	Yes	No
6	<ul style="list-style-type: none"> Using a high impedance DVOM check for continuity between EGO 1 connector signal ground pin C and EGO 1 signal pin A Do you have continuity?		Repair the shorted circuit as necessary. Refer to Wiring Repairs in Engine Electrical.	Go to Step (7)
7	<ul style="list-style-type: none"> Using a high impedance DVOM check for continuity between EGO 1 heater ground pin D and ECM pin 49 Do you have continuity?		Go to Step (8)	Repair the open EGO heater ground
8	<ul style="list-style-type: none"> Replace EGO 1 sensor Is the replacement complete?		Go to Step (9)	-
9	<ul style="list-style-type: none"> Remove all test equipment except the DST. Connect any disconnected components, fuses, etc. Using the DST clear DTC information from the ECM. Turn the ignition OFF and wait 30 seconds. Start the engine and operate the vehicle to full operating temperature Observe the MIL Observe engine performance and drivability After operating the engine within the test parameters of DTC-1161 check for any stored codes. Does the engine operate normally with no stored codes?		System OK	Go to OBD System Check

DTC 1162-Adaptive Learn Low (LPG) (SPN 520202:FMI 1)

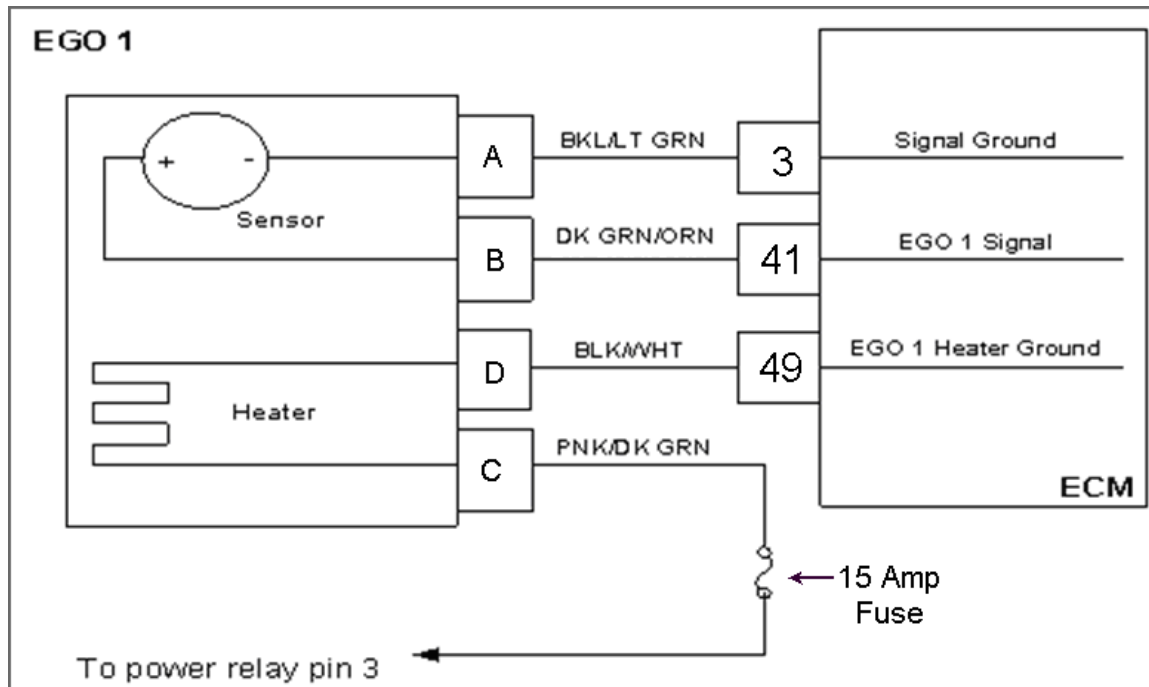

Conditions for Setting the DTC

- Heated Oxygen Sensor
- Check Condition-Engine running
- Fault Condition-Adaptive multiplier out of range greater than -30%
- MIL-ON

Circuit Description

The EGO1 sensor is used to determine if the fuel flow to the engine is correct by measuring the oxygen content in the exhaust gas. The ECM uses this information to correct the fuel flow with the Closed Loop multiplier and Adaptive multiplier. This fault will set if the adaptive multiplier exceeds the limits of normal operation. Always run the fuel system diagnostics before using the following diagnostic chart.

Diagnostic Aid

Fuel System High secondary fuel pressure will cause the system to run rich. A worn fuel mixer, faulty EPR (Electronic Pressure Regulator) may also cause the system to run rich.

Fuel Quality A drastic variation in fuel quality (very high butane content) may cause the fuel system to run rich. Be sure that the specified HD-5 or HD-10 motor fuel grade propane is used.

Air Filter A plugged, damaged or modified air filter may cause the system to run rich.

DTC 1162-Adaptive Learn Low LPG

Step	Action	Value(s)	Yes	No
1	<ul style="list-style-type: none"> Perform the On-Board (OBD) System Check? Are any other DTCs present?		Go to Step (3)	Go to Step (2)
2	Visually and physically check the following items: <ul style="list-style-type: none"> The air intake duct for being collapsed or restricted The air filter for being plugged The EGO sensor is installed securely and the wire leads not damaged or contacting the secondary ignition wires ECM grounds for being clean and tight. Fuel system diagnostic checks Was a repair made?		Go to Step (6)	Go to Step (4)
3	<ul style="list-style-type: none"> Diagnose any other DTC codes before proceeding with this chart. Have any other DTC codes been detected, diagnosed and repaired?		Go to Step (6)	Go to Step (4)
4	<ul style="list-style-type: none"> Key OFF Disconnect EGO sensor wire harness connector C005 Disconnect ECM wire harness connector C001 Key ON Using a DVOM check for voltage at EGO 1 connector signal pin A and engine ground Do you have voltage?		Repair the circuit as necessary. Refer to Wiring Repairs in Engine Electrical.	Go to Step (5)
5	<ul style="list-style-type: none"> Replace EGO sensor Is the replacement complete?		Go to Step (6)	-
6	<ul style="list-style-type: none"> Remove all test equipment except the DST. Connect any disconnected components, fuses, etc. Using the DST clear DTC information from the ECM. Turn the ignition OFF and wait 30 seconds. Start the engine and operate the vehicle to full operating temperature Observe the MIL Observe engine performance and drivability After operating the engine within the test parameters of DTC-1162 check for any stored codes. Does the engine operate normally with no stored codes?		System OK	Go to OBD System Check

DTC 1171-EPR Pressure Higher Than Expected

(SPN 520260:FMI 0)

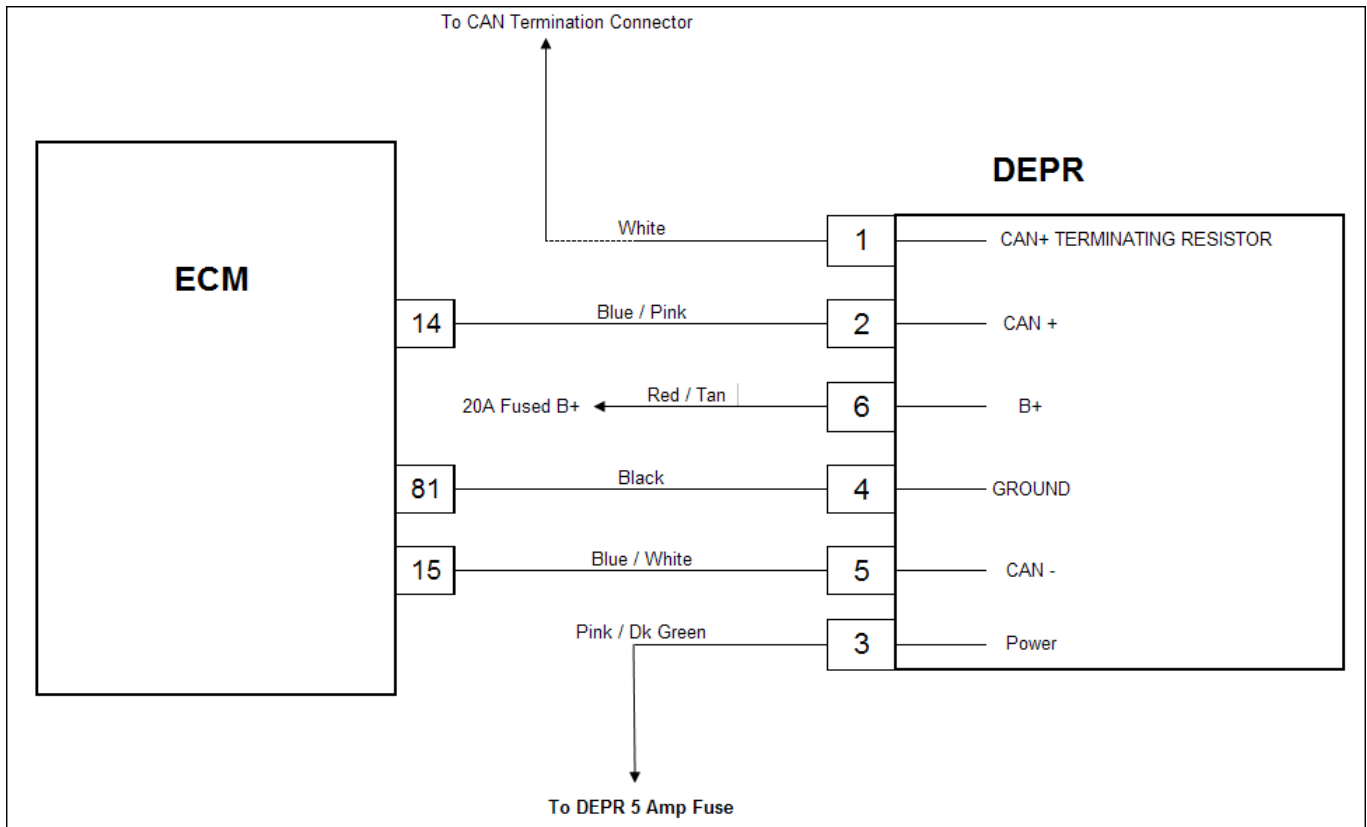

Conditions for Setting the DTC

- EPR delivery pressure
- Check condition-Engine running or cranking
- MIL-ON during active fault
- Fault condition-EPR actual pressure greater than 1.5 inches above commanded pressure
- Adaptive disabled
- Closed loop disabled

Circuit Description

The EPR (Electronic Pressure Regulator) unit measures and controls the amount of fuel that is able to pass to the fuel mixer. This code will set in the event the actual pressure is 1.5 inches water pressure higher than the actual commanded pressure. Adaptive learn is disabled and the MIL command is ON during this fault.

Diagnostic Aid

Always run the fuel system diagnostic pressure check before proceeding with the following diagnostic chart. High secondary fuel pressure due to a worn or damaged primary or secondary seat may cause this fault to set.

DTC 1171-EPR Pressure Higher Than Expected

Step	Action	Value(s)	Yes	No
1	Did you perform the On-Board (OBD) System Check?	-	Go to Step (2)	Go to OBD System Check Section
2	Did you run the fuel pressure diagnostic test in the fuel system diagnostic section with no problems found?		Go to Step (4)	Go to Step (3)
3	<ul style="list-style-type: none"> • Run the EPR pressure test in the fuel system diagnostic section Did the EPR pass the fuel pressure test specifications?		Go to Step (4)	Follow the EPR service recommendations from the fuel pressure test chart.
4	<ul style="list-style-type: none"> • Inspect the EPR electrical connector pins C018 for damage, corrosion or contamination. Did you find a problem?		Repair the circuit as necessary. Refer to wire harness repair section.	Go to Step (5)
5	<ul style="list-style-type: none"> • Replace or repair the EPR Is the replacement complete?		Go to Step (6)	-
6	<ul style="list-style-type: none"> • Remove all test equipment except the DST. • Connect any disconnected components, fuses, etc. • Using the DST clear DTC information from the ECM. • Turn the ignition OFF and wait 30 seconds. • Start the engine and operate the vehicle to full operating temperature • Observe the MIL • Observe engine performance and drivability. • After operating the engine within the test parameters of DTC1171 check for any stored codes. Does the engine operate normally with no stored codes?		System OK	Go to OBD System Check

DTC 1172-EPR Pressure Lower Than Expected (SPN 520260:FMI 1)

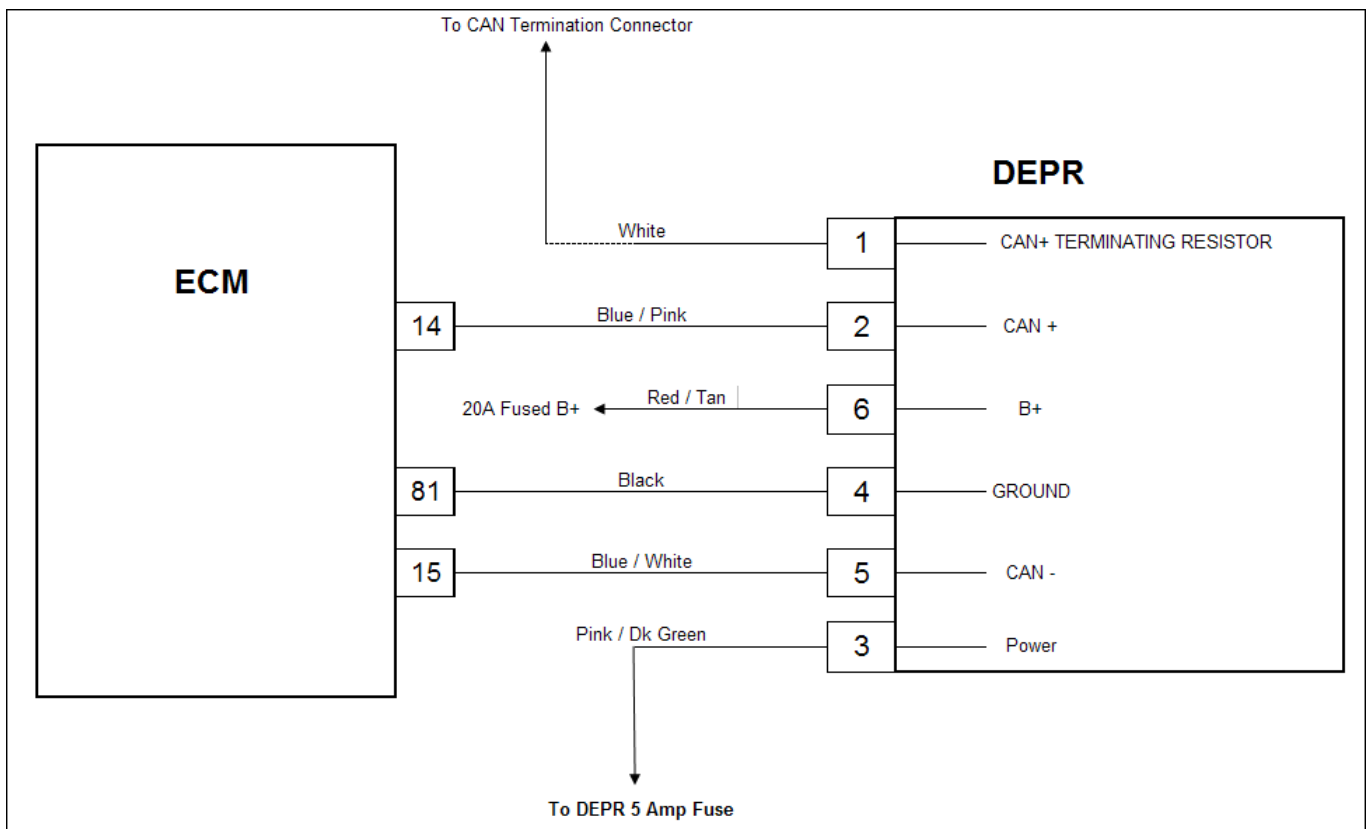

Conditions for Setting the DTC

- EPR delivery pressure
- Check condition-Engine running or cranking
- MIL-ON during active fault
- Fault condition-EPR actual pressure less than 1.5 inches below commanded pressure
- Adaptive disabled
- Closed loop disabled

Circuit Description

The EPR (Electronic Pressure Regulator) unit measures and controls the amount of fuel that is able to pass to the fuel mixer. This code will set in the event the actual pressure is 1.0 inches water pressure lower than the actual commanded pressure. Adaptive is disabled and the MIL command is ON during this fault.

Diagnostic Aid

Always run the fuel system diagnostic pressure check before proceeding with the following diagnostic chart. Low secondary fuel pressure due to a fuel restriction or faulty regulator may cause this fault.

DTC 1172-EPR Pressure Lower Than Expected

Step	Action	Value(s)	Yes	No
1	Did you perform the On-Board (OBD) System Check?	-	Go to Step (2)	Go to OBD System Check Section
2	Did you run the fuel pressure diagnostic test in the fuel system diagnostic section with no problems found?		Go to Step (4)	Go to Step (3)
3	<ul style="list-style-type: none"> • Run the EPR pressure test in the fuel system diagnostic section Did the EPR pass the fuel pressure test specifications?		Go to Step (4)	Follow the EPR service recommendations from the fuel pressure test chart.
4	<ul style="list-style-type: none"> • Inspect the EPR electrical connector C018 for damage, corrosion or contamination. Did you find a problem?		Repair the circuit as necessary. Refer to wire harness repair section.	Go to Step (5)
5	<ul style="list-style-type: none"> • Replace or repair the EPR Is the replacement complete?		Go to Step (6)	-
6	<ul style="list-style-type: none"> • Remove all test equipment except the DST. • Connect any disconnected components, fuses, etc. • Using the DST clear DTC information from the ECM. • Turn the ignition OFF and wait 30 seconds. • Start the engine and operate the vehicle to full operating temperature • Observe the MIL • Observe engine performance and drivability • After operating the engine within the test parameters of DTC1172 check for any stored codes. Does the engine operate normally with no stored codes?		System OK	Go to OBD System Check

DTC 1173-EPR Communication Lost (SPN 520260:FMI 31)

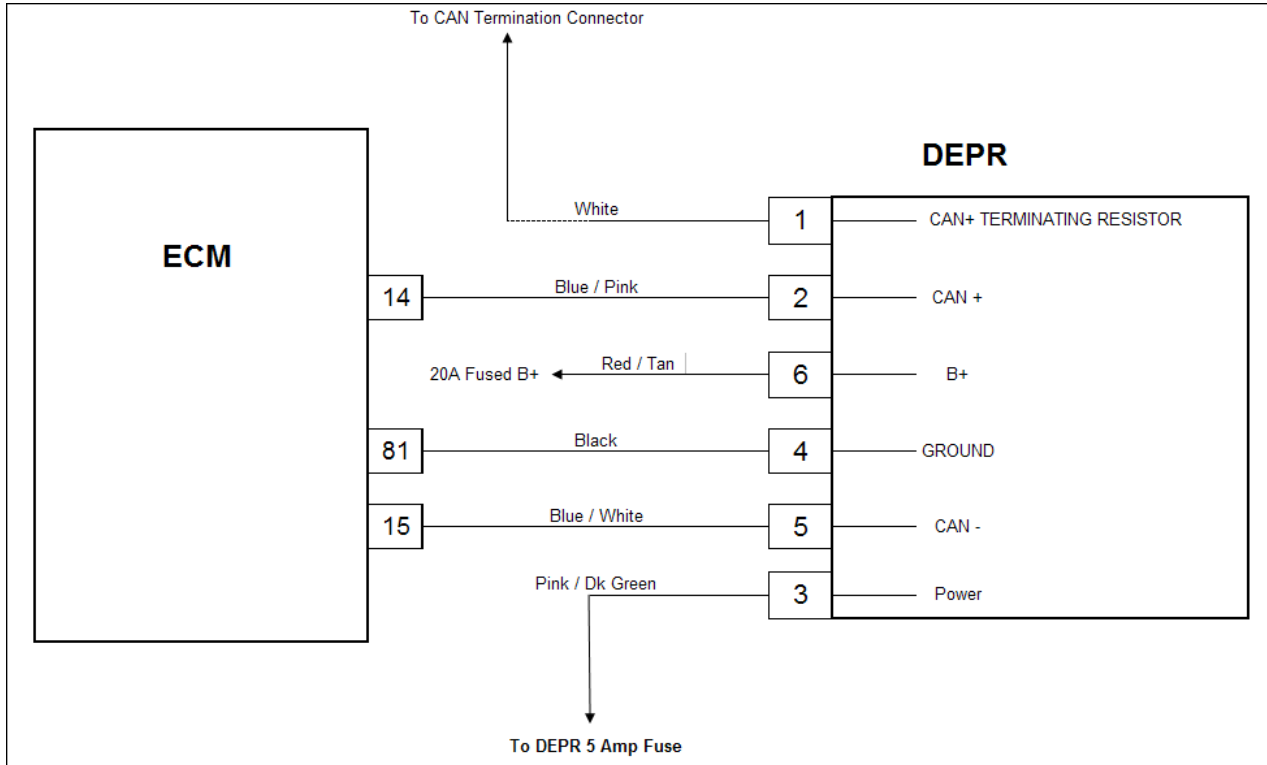

Conditions for Setting the DTC

- EPR CAN communication
- Check condition-Engine running or cranking
- MIL-On during active fault
- Fault condition-No packets received within 500 ms
- Adaptive disabled

Circuit Description

The EPR (Electronic Pressure Regulator) unit measures and controls the amount of fuel that is able to pass to the fuel mixer. This code will set in the event communication with the ECM is lost. The MIL command is on.

DTC 1173-EPR Communication Lost

Step	Action	Value(s)	Yes	No
1	Did you perform the On-Board (OBD) System Check?	-	Go to Step (2)	Go to OBD System Check Section
2	<ul style="list-style-type: none"> • Key ON • DST (Diagnostic Scan Tool) connected in the system data mode • Clear DTC1173 • Key OFF • Key ON, and attempt to start the engine Does DTC1173 re-set?		Go to step (3)	Intermittent problem. Go to Intermittent Problem section in the electrical section of this manual.
3	<ul style="list-style-type: none"> • Key OFF • Disconnect EPR electrical connector C018 • Key ON • Using a DVOM check for system power between EPR connector pin 7 and engine ground (Be sure to activate relay control ON using the DST function or check before ECM relay control times out) Do you have power?	System battery voltage	Go to step (7)	Go to step (4)
4	<ul style="list-style-type: none"> • Check the 10A (F5) fuse Is the fuse open?		Go to step (5)	Go to step (6)
5	<ul style="list-style-type: none"> • Replace the F5 fuse Is the replacement complete?		Go to step (17)	-
6	<ul style="list-style-type: none"> • Using a DVOM check for system power at power relay terminal 3 (Be sure to activate relay control ON using the DST function or check before ECM relay control times out) Do you have power?	System battery voltage	Repair the open circuit between power relay pin 3 and EPR pin 7 Go to step (17)	Repair the power relay circuit as required Go to step (17)
7	<ul style="list-style-type: none"> • Using a DVOM check for continuity between EPR connector pin 6 and engine ground Do you have continuity?		Go to step (8)	Repair the open ground circuit as necessary. Refer to wiring repairs in engine electrical

Step	Action	Value(s)	Yes	No
8	<ul style="list-style-type: none"> • Key OFF • Disconnect the EPR connector C018 • Disconnect the ECM connector C001 • Using a DVOM check for continuity between EPR pin 5 and ECM pin 15 Do you have continuity?		Go to step (9)	Repair the open circuit as necessary. Refer to wiring repairs in engine electrical
9	<ul style="list-style-type: none"> • Using a DVOM check for continuity between EPR pin 2 and ECM pin 14 Do you have continuity?		Go to step (10)	Repair the open circuit as necessary. Refer to wiring repairs in engine electrical
10	<ul style="list-style-type: none"> • Using a DVOM check for continuity between EPR pin 4 and ECM pin 81 Do you have continuity?		Go to step (11)	Repair the open circuit as necessary. Refer to wiring repairs in engine electrical
11	<ul style="list-style-type: none"> • Using a DVOM check for continuity between EPR pin 3 and B+ Do you have continuity?		Go to step (12)	Repair the open circuit as necessary. Refer to wiring repairs in engine electrical
12	<ul style="list-style-type: none"> • Using a DVOM check for continuity between EPR pin 6 and B+ Do you have continuity?		Go to step (13)	Repair the open circuit as necessary. Refer to wiring repairs in engine electrical
13	<ul style="list-style-type: none"> • Disconnect DST from the DLC connector C014 • Using a DVOM check for continuity between engine ground and EPR pin 4 Do you have continuity?		Repair the shorted to ground CAN circuit as necessary. Refer to wiring repairs in engine electrical	Go to step (14)
14	<ul style="list-style-type: none"> • Replace the EPR Is the replacement complete?		Go to step (15)	—

Step	Action	Value(s)	Yes	No
15	<ul style="list-style-type: none"> • Remove all test equipment and reconnect the DST. • Connect any disconnected components, fuses, etc. • Using the DST clear DTC information from the ECM. • Turn the ignition OFF and wait 30 seconds. • Start the engine and operate the vehicle to full operating temperature • Observe the MIL • Observe engine performance and driveability • After operating the engine within the test parameters of DTC1173 check for any stored codes. <p>Does DTC1173 still re-set?</p>		Go to step (16)	System OK
16	<ul style="list-style-type: none"> • Replace the ECM <p>Is the replacement complete?</p>		Go to step (17)	—
17	<ul style="list-style-type: none"> • Remove all test equipment except the DST. • Connect any disconnected components, fuses, etc. • Using the DST clear DTC information from the ECM. • Turn the ignition OFF and wait 30 seconds. • Start the engine and operate the vehicle to full operating temperature • Observe the MIL • Observe engine performance and driveability • After operating the engine within the test parameters of DTC1173 check for any stored codes. <p>Does the engine operate normally with no stored codes?</p>		System OK	Go to OBD System Check

DTC 1176-EPR Internal Actuator Fault (SPN 520260:FMI 12)

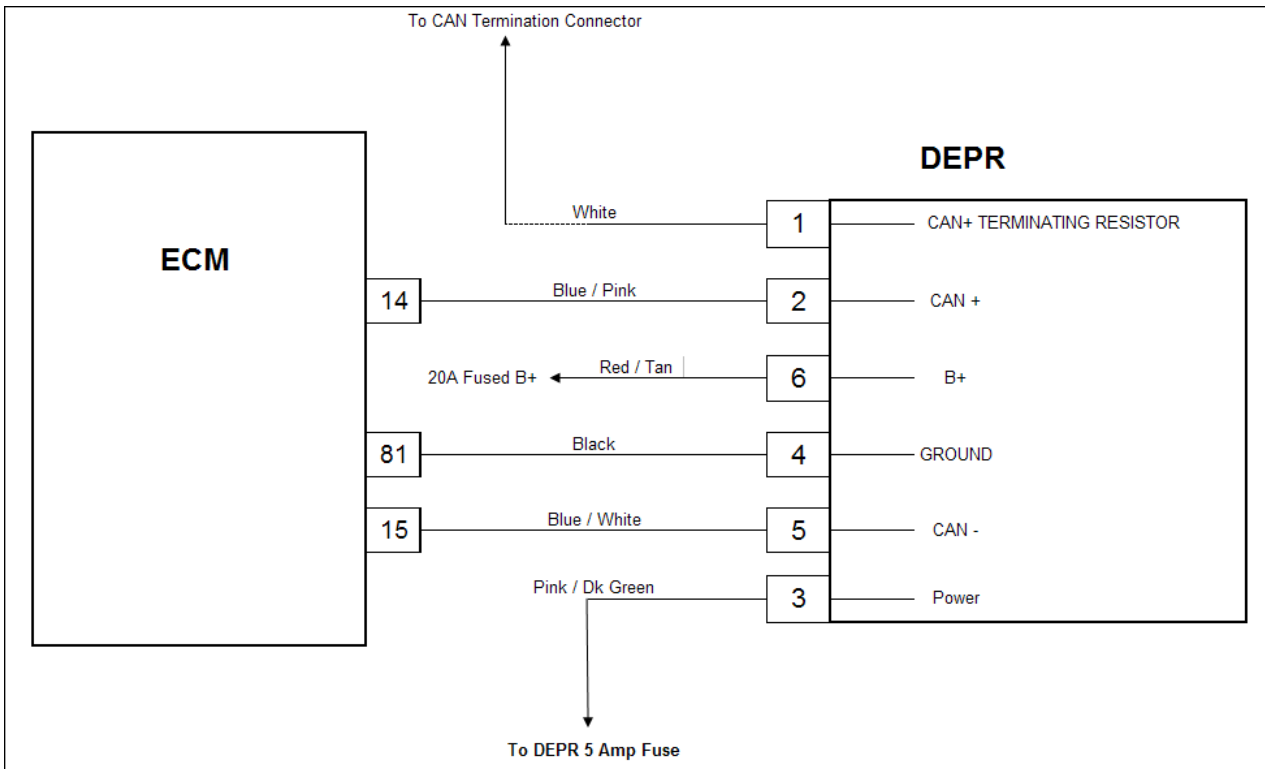

Conditions for Setting the DTC

- EPR internal actuator test
- Check condition-Engine running or cranking
- MIL-ON during active fault
- Fault condition-Failed actuator
- Adaptive disabled

Circuit Description

The EPR (Electronic Pressure Regulator) unit measures and controls the amount of fuel that is able to pass to the fuel mixer. Pressure readings are sent over the CAN to the ECM and in return the ECM sends back a control signal to the EPR to increase or decrease pressure for precise mixture control. This code will set if the ECM detects an internal actuator fault with the EPR. In the event of multiple code sets, always start the diagnostic repair with the lowest numerical value DTC first. In most instances the EPR will need to be replaced in the event of this code set.

DTC 1176-EPR Internal Actuator Fault

Step	Action	Value(s)	Yes	No
1	Did you perform the On-Board (OBD) System Check?	-	Go to Step (2)	Go to OBD System Check Section
2	<ul style="list-style-type: none"> • DST connected and in the system data mode. • Check for any other current or active DTCs Does the DST show any other codes set?		Go to Step (3)	Go to Step (6)
3	<ul style="list-style-type: none"> • Repair any other DTCs set starting with the lowest DTC number first. Have the other DTCs set been corrected?		Go to Step (4)	–
4	<ul style="list-style-type: none"> • Remove all test equipment except the DST. • Connect any disconnected components, fuses, etc. • Using the DST clear DTC information from the ECM. • Turn the ignition OFF and wait 30 seconds. • Start the engine and operate the vehicle to full operating temperature. • Observe the MIL. • Observe engine performance and driveability • After operating the engine within the test parameters of DTC1176 check for any stored codes. Does DTC 1176 still re-set?		Go to Step (5)	System OK
5	<ul style="list-style-type: none"> • Replace the EPR Is the replacement complete?		Go to Step (6)	–
6	<ul style="list-style-type: none"> • Remove all test equipment except the DST. • Connect any disconnected components, fuses, etc. • Using the DST clear DTC information from the ECM. • Turn the ignition OFF and wait 30 seconds. • Start the engine and operate the vehicle to full operating temperature. • Observe the MIL. • Observe engine performance and driveability • After operating the engine within the test parameters of DTC1176 check for any stored codes. Does the engine operate normally with no stored codes?		System OK	Go to OBD System Check

DTC 1177-EPR internal Circuitry Fault **(SPN 520260:FMI 12)**

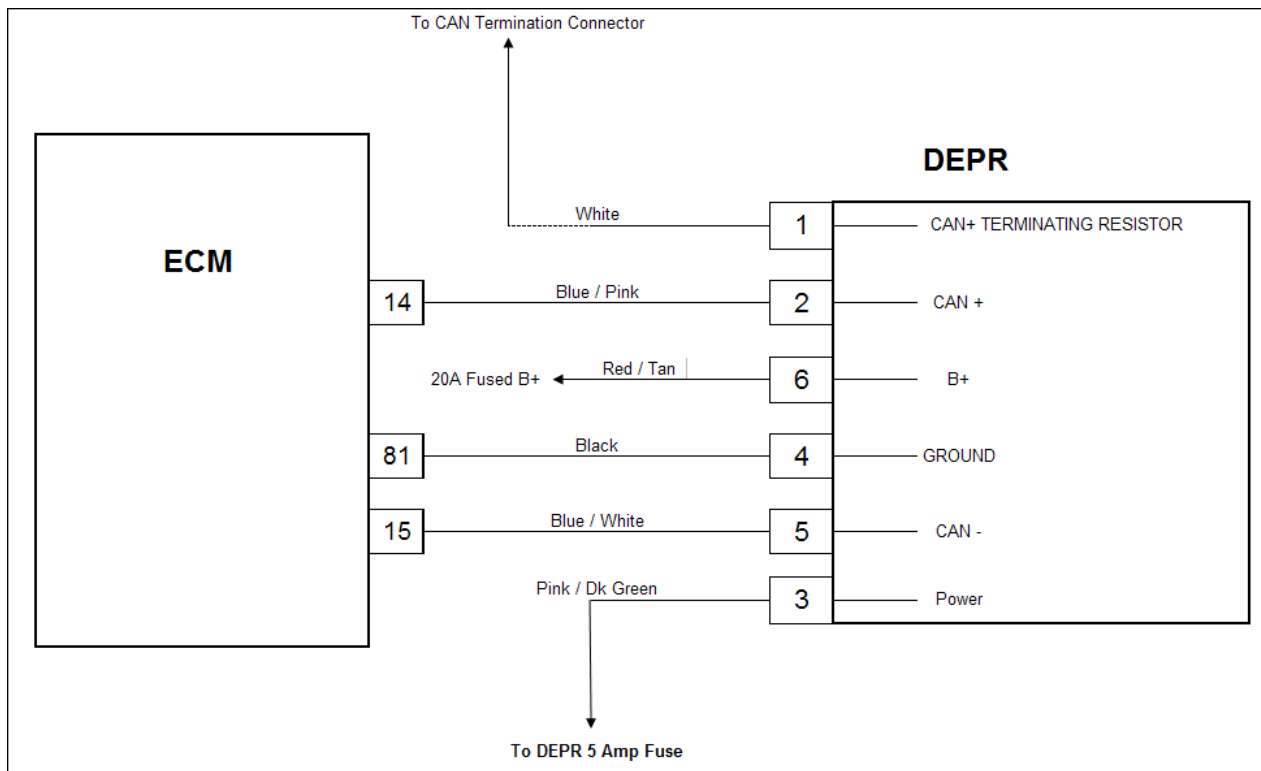

Conditions for Setting the DTC

- EPR internal circuitry test
- Check condition-Engine running or cranking
- MIL-ON during active fault
- Fault condition-
- Adaptive disabled

Circuit Description

The EPR (Electronic Pressure Regulator) unit measures and controls the amount of fuel that is able to pass to the fuel mixer. Pressure readings are sent over the CAN to the ECM and in return the ECM sends back a control signal to the EPR to increase or decrease pressure for precise mixture control. This code will set if the ECM detects an internal circuitry fault in the EPR. In the event of multiple code sets, always start the diagnostic repair with the lowest numerical value DTC first. In most instances the EPR will need to be replaced in the event of this code set.

DTC 1177-EPR Internal Circuitry Failure

Step	Action	Value(s)	Yes	No
1	Did you perform the On-Board (OBD) System Check?	-	Go to Step (2)	Go to OBD System Check Section
2	<ul style="list-style-type: none"> • DST connected and in the system data mode • Check for any other current or active DTCs Does the DST show any other codes set?		Go to Step (3)	Go to Step (6)
3	<ul style="list-style-type: none"> • Repair any other DTCs set starting with the lowest DTC number first Have the other DTCs set been corrected?		Go to Step (4)	-
4	<ul style="list-style-type: none"> • Remove all test equipment except the DST. • Connect any disconnected components, fuses, etc. • Using the DST clear DTC information from the ECM. • Turn the ignition OFF and wait 30 seconds. • Start the engine and operate the vehicle to full operating temperature • Observe the MIL • Observe engine performance and driveability • After operating the engine within the test parameters of DTC1177 check for any stored codes. Does DTC 1177 still re-set?		Go to Step (5)	System OK
5	<ul style="list-style-type: none"> • Replace the EPR Is the replacement complete?		Go to Step (6)	-
6	<ul style="list-style-type: none"> • Remove all test equipment except the DST. • Connect any disconnected components, fuses, etc. • Using the DST clear DTC information from the ECM. • Turn the ignition OFF and wait 30 seconds. • Start the engine and operate the vehicle to full operating temperature • Observe the MIL • Observe engine performance and driveability • After operating the engine within the test parameters of DTC1177 check for any stored codes. Does the engine operate normally with no stored codes?		System OK	Go to OBD System Check

DTC 1612-RTI 1 Loss (SPN 629:FMI 31)

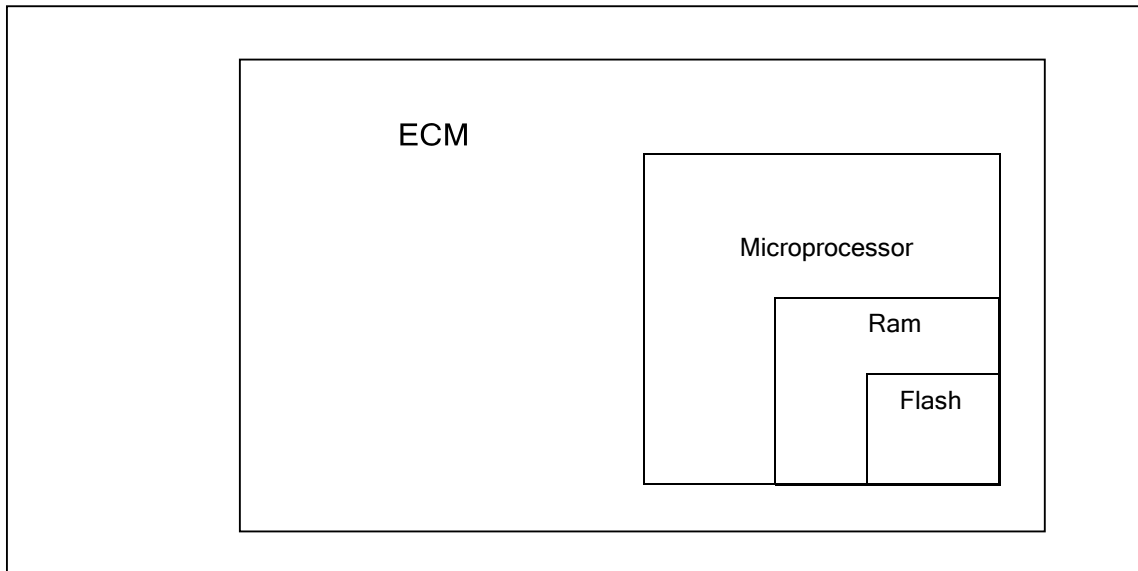

Conditions for Setting the DTC

- Engine Control Module
- Check Condition-Key on
- Fault Condition-Internal microprocessor error
- MIL-ON
- Adaptive-Disabled for the remainder of the key-ON cycle

Circuit Description

The ECM has several internal checks that must be satisfied each time an instruction is executed. Several different things can happen within the microprocessor that will cause this fault. The ECM will attempt to reset itself in the event this fault is set. The MIL command is on and will remain on until the code is cleared using the DST.

DTC 1612-RT 1 Loss

Step	Action	Value(s)	Yes	No
1	Did you perform the On-Board (OBD) System Check?	-	Go to Step (2)	Go to OBD System Check Section
2	<ul style="list-style-type: none"> • Key ON, Engine Running • DST (Diagnostic Scan Tool) connected in System Data Mode • Clear system fault code Does DTC 1612 reset with the engine idling?		Go to Step (3)	Intermittent problem Go to Intermittent section
3	<ul style="list-style-type: none"> • Check ECM power and ground circuits Did the power and ground circuits check OK?		Go to Step (4)	Repair the circuit as necessary. Refer to Wiring Repairs in Engine Electrical.
4	<ul style="list-style-type: none"> • Replace ECM Is the replacement complete?		Go to Step (5)	-
5	<ul style="list-style-type: none"> • Remove all test equipment except the DST. • Connect any disconnected components, fuses, etc. • Using the DST clear DTC information from the ECM. • Turn the ignition OFF and wait 30 seconds. • Start the engine and operate the vehicle to full operating temperature • Observe the MIL • Observe engine performance and drivability • After operating the engine within the test parameters of DTC-1612 check for any stored codes. Does the engine operate normally with no stored codes?		System OK	Go to OBD System Check

DTC 1613-RTI 2 Loss (SPN 629:FMI 31)

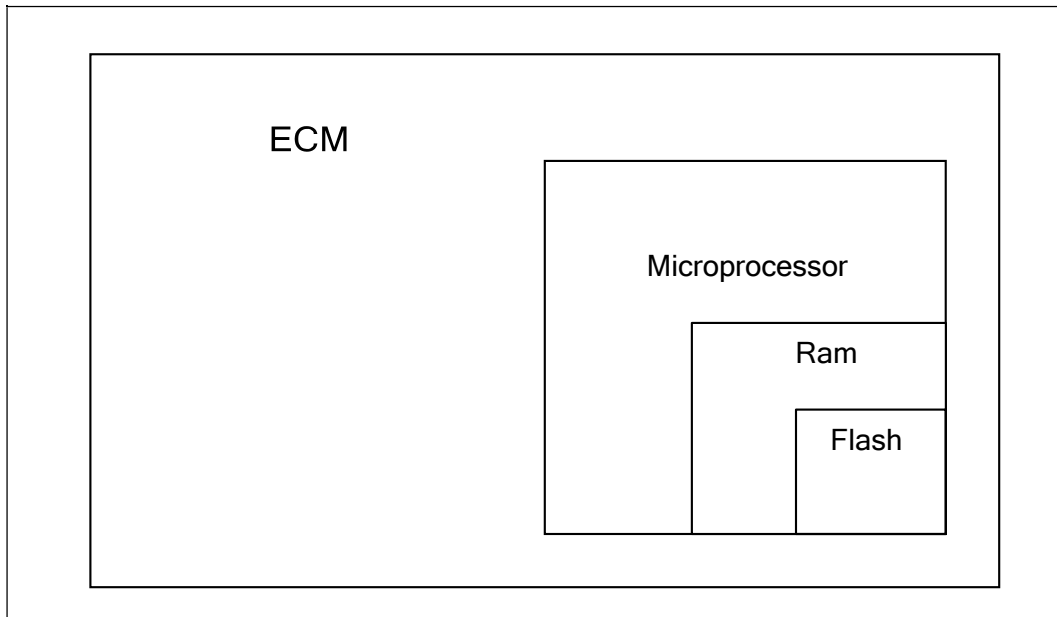

Conditions for Setting the DTC

- Engine Control Module
- Check Condition-Key on
- Fault Condition-Internal microprocessor error
- MIL-ON
- Adaptive-Disabled for the remainder of the key-ON cycle

Circuit Description

The ECM has several internal checks that must be satisfied each time an instruction is executed. Several different things can happen within the microprocessor that will cause this fault. The ECM will attempt to reset itself in the event this fault is set. The MIL command is on and will remain on until the code is cleared using the DST.

DTC 1613-RTI 2 Loss

Step	Action	Value(s)	Yes	No
1	Did you perform the On-Board (OBD) System Check?	-	Go to Step (2)	Go to OBD System Check Section
2	<ul style="list-style-type: none"> • Key ON, Engine Running • DST (Diagnostic Scan Tool) connected in System Data Mode • Clear system fault code Does DTC 1613 reset with the engine idling?		Go to Step (3)	Intermittent problem Go to Intermittent section
3	<ul style="list-style-type: none"> • Check ECM power and ground circuits Did the power and ground circuits check OK?		Go to Step (4)	Repair the circuit as necessary. Refer to Wiring Repairs in Engine Electrical.
4	<ul style="list-style-type: none"> • Replace ECM Is the replacement complete?		Go to Step (5)	-
5	<ul style="list-style-type: none"> • Remove all test equipment except the DST. • Connect any disconnected components, fuses, etc. • Using the DST clear DTC information from the ECM. • Turn the ignition OFF and wait 30 seconds. • Start the engine and operate the vehicle to full operating temperature • Observe the MIL • Observe engine performance and drivability • After operating the engine within the test parameters of DTC-1613 check for any stored codes. Does the engine operate normally with no stored codes?		System OK	Go to OBD System Check

DTC 1614-RTI 3 Loss (SPN 629:FMI 31)

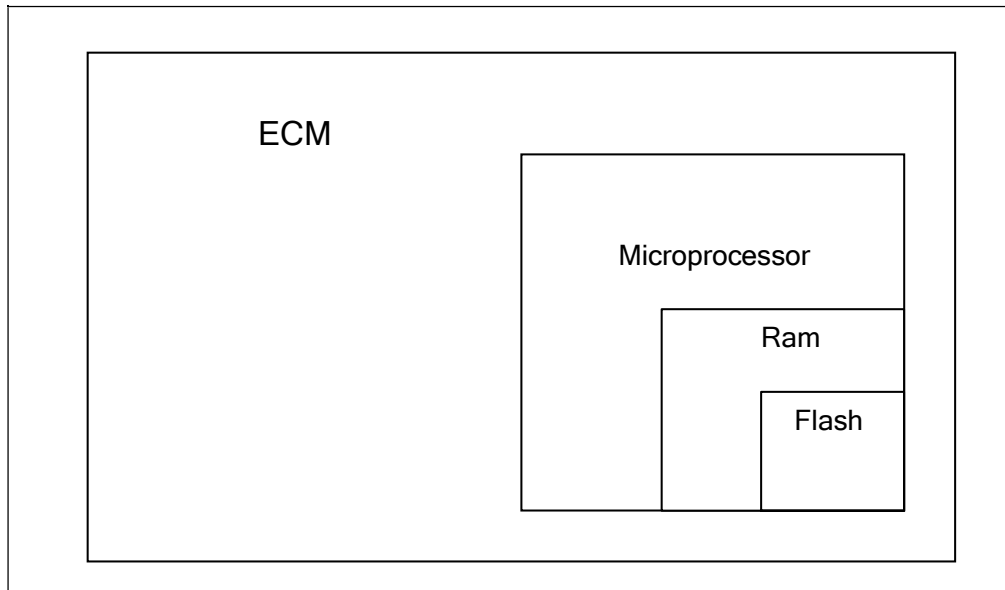

Conditions for Setting the DTC

- Engine Control Module
- Check Condition-Key on
- Fault Condition-Internal microprocessor error
- MIL-ON
- Adaptive-Disabled for the remainder of the key-ON cycle

Circuit Description

The ECM has several internal checks that must be satisfied each time an instruction is executed. Several different things can happen within the microprocessor that will cause this fault. The ECM will attempt to reset itself in the event this fault is set. The MIL command is on and will remain on until the code is cleared using the DST.

DTC 1614-RTI 3 Loss

Step	Action	Value(s)	Yes	No
1	Did you perform the On-Board (OBD) System Check?	-	Go to Step (2)	Go to OBD System Check Section
2	<ul style="list-style-type: none"> • Key ON, Engine Running • DST (Diagnostic Scan Tool) connected in System Data Mode • Clear system fault code Does DTC 1614 reset with the engine idling?		Go to Step (3)	Intermittent problem Go to Intermittent section
3	<ul style="list-style-type: none"> • Check ECM power and ground circuits Did the power and ground circuits check OK?		Go to Step (4)	Repair the circuit as necessary. Refer to Wiring Repairs in Engine Electrical.
4	<ul style="list-style-type: none"> • Replace ECM Is the replacement complete?		Go to Step (5)	-
5	<ul style="list-style-type: none"> • Remove all test equipment except the DST. • Connect any disconnected components, fuses, etc. • Using the DST clear DTC information from the ECM. • Turn the ignition OFF and wait 30 seconds. • Start the engine and operate the vehicle to full operating temperature • Observe the MIL • Observe engine performance and drivability • After operating the engine within the test parameters of DTC-1614 check for any stored codes. Does the engine operate normally with no stored codes?		System OK	Go to OBD System Check

DTC 1615-A/D Loss (SPN 629:FMI 31)

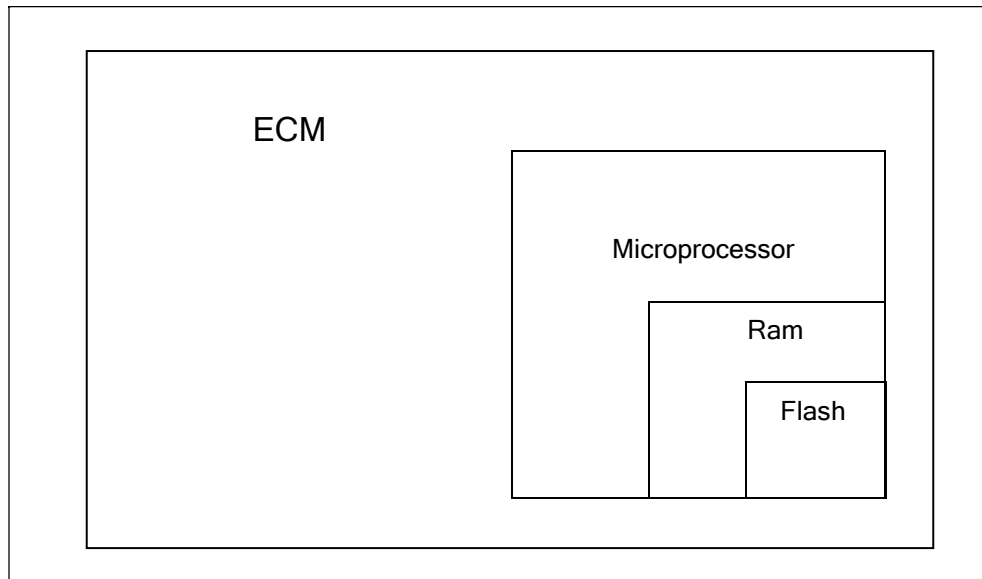

Conditions for Setting the DTC

- Engine Control Module
- Check Condition-Key on
- Fault Condition-Internal microprocessor error
- MIL-ON
- Adaptive-Disabled for the remainder of the key-ON cycle

Circuit Description

The ECM has several internal checks that must be satisfied each time an instruction is executed. Several different things can happen within the microprocessor that will cause this fault. The ECM will attempt to reset itself in the event this fault is set. The MIL command is on and will remain on until the code is cleared using the DST.

DTC 1615-A/D Loss

Step	Action	Value(s)	Yes	No
1	Did you perform the On-Board (OBD) System Check?	-	Go to Step (2)	Go to OBD System Check Section
2	<ul style="list-style-type: none"> • Key ON, Engine Running • DST (Diagnostic Scan Tool) connected in System Data Mode • Clear system fault code Does DTC 1615 reset with the engine idling?		Go to Step (3)	Intermittent problem Go to Intermittent section
3	<ul style="list-style-type: none"> • Check ECM power and ground circuits Did the power and ground circuits check OK?		Go to Step (4)	Repair the circuit as necessary. Refer to Wiring Repairs in Engine Electrical.
4	<ul style="list-style-type: none"> • Replace ECM Is the replacement complete?		Go to Step (5)	-
5	<ul style="list-style-type: none"> • Remove all test equipment except the DST. • Connect any disconnected components, fuses, etc. • Using the DST clear DTC information from the ECM. • Turn the ignition OFF and wait 30 seconds. • Start the engine and operate the vehicle to full operating temperature • Observe the MIL • Observe engine performance and drivability • After operating the engine within the test parameters of DTC-1615 check for any stored codes. Does the engine operate normally with no stored codes?		System OK	Go to OBD System Check

DTC 1616-Invalid Interrupt (SPN 629:FMI 31)

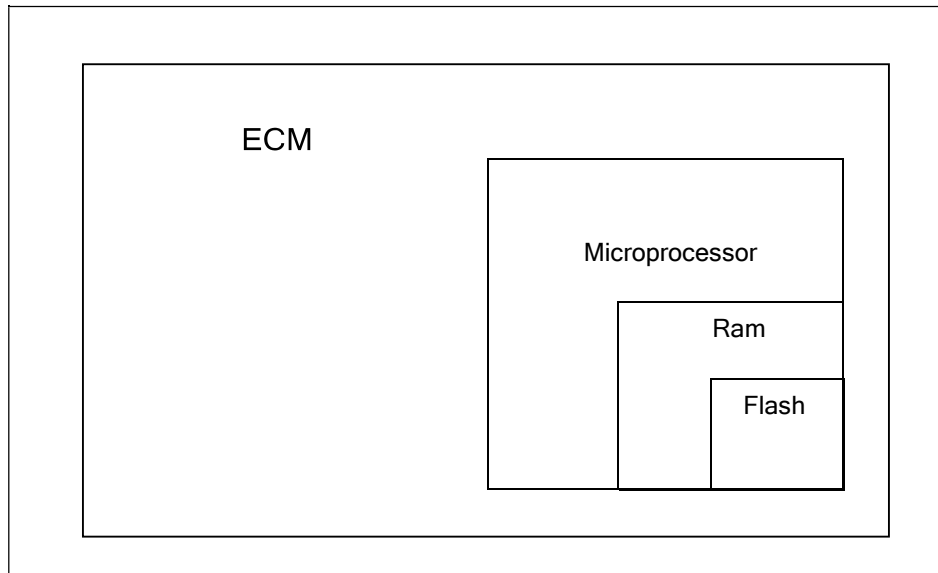

Conditions for Setting the DTC

- Engine Control Module
- Check Condition-Key on
- Fault Condition-Internal microprocessor error
- MIL-ON
- Adaptive-Disabled for the remainder of the key-ON cycle

Circuit Description

The ECM has several internal checks that must be satisfied each time an instruction is executed. Several different things can happen within the microprocessor that will cause this fault. The ECM will attempt to reset itself in the event this fault is set. The MIL command is on and will remain on until the code is cleared using the DST.

DTC 1616-Invalid Interrupt

Step	Action	Value(s)	Yes	No
1	Did you perform the On-Board (OBD) System Check?	-	Go to Step (2)	Go to OBD System Check Section
2	<ul style="list-style-type: none"> • Key ON, Engine Running • DST (Diagnostic Scan Tool) connected in System Data Mode • Clear system fault code Does DTC 1616 reset with the engine idling?		Go to Step (3)	Intermittent problem Go to Intermittent section
3	<ul style="list-style-type: none"> • Check ECM power and ground circuits Did the power and ground circuits check OK?		Go to Step (4)	Repair the circuit as necessary. Refer to Wiring Repairs in Engine Electrical.
4	<ul style="list-style-type: none"> • Replace ECM Is the replacement complete?		Go to Step (5)	-
5	<ul style="list-style-type: none"> • Remove all test equipment except the DST. • Connect any disconnected components, fuses, etc. • Using the DST clear DTC information from the ECM. • Turn the ignition OFF and wait 30 seconds. • Start the engine and operate the vehicle to full operating temperature • Observe the MIL • Observe engine performance and drivability • After operating the engine within the test parameters of DTC-1616 check for any stored codes. Does the engine operate normally with no stored codes?		System OK	Go to OBD System Check

DTC 1626-CAN Tx Failure

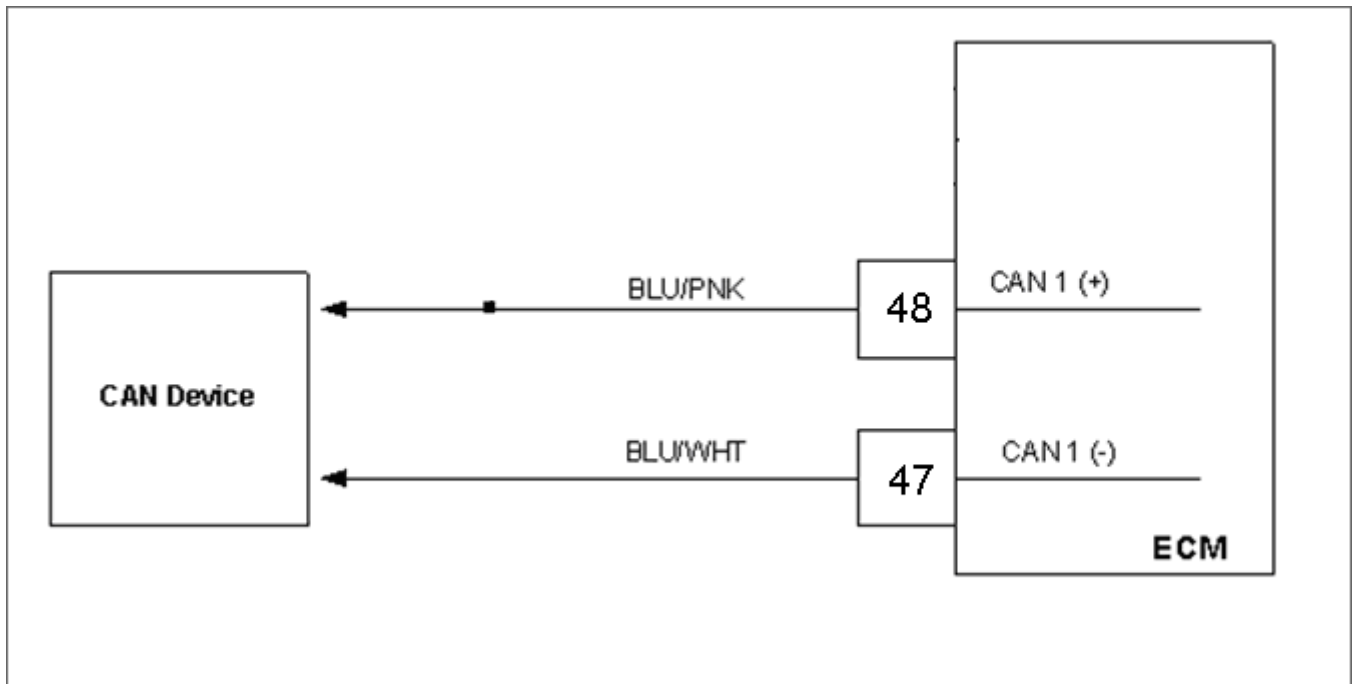

Conditions for Setting the DTC

- CAN Tx
- Check Condition-Engine running
- Fault Condition-CAN Tx error 120 packets lost within 1 second
- MIL-ON

Circuit description

The CAN bus (controller area network) is used by the ECM to communicate with other digital devices used throughout the fuel system. Information is sent over the CAN bus in digital information "packets" that contain information for various control functions. This fault will set if the ECM detects 120 packets lost within a one second time period. The MIL command is ON.

DTC 1626-CAN Tx Failure

Step	Action	Value(s)	Yes	No
1	Did you perform the On-Board (OBD) System Check?	-	Go to Step (2)	Go to OBD System Check Section
2	<ul style="list-style-type: none"> • Key ON, Engine Running • DST (Diagnostic Scan Tool) connected in System Data Mode • Clear system fault code Does DTC1626 reset with the engine idling?		Go to Step (3)	Intermittent problem Go to Intermittent section
3	<ul style="list-style-type: none"> • Check that the ECM power connection C019 is clean, tight and in the proper location. • Check that the ECM ground connection C010 is clean, tight and in the proper location. Are the power and ground circuits OK?		Go to Step (4)	Repair the circuit as necessary. Refer to Wiring Repairs in Engine Electrical.
4	<ul style="list-style-type: none"> • Using a DVOM check for continuity between ECM pins 47 and 48 Do you have continuity between them?		Repair the shorted circuit as necessary. Refer to Wiring Repairs in Engine Electrical.	Go to Step (5)
5	<ul style="list-style-type: none"> • Using a DVOM check for continuity to engine ground on pin 14 Do have continuity to engine ground?		Repair the shorted to ground circuit as necessary. Refer to Wiring Repairs in Engine Electrical.	Go to Step (6)
6	<ul style="list-style-type: none"> • Using a DVOM check for continuity to battery positive on pin 14. Do have continuity?		Repair the shorted to ground circuit as necessary. Refer to Wiring Repairs in Engine Electrical.	Go to Step (7)
7	<ul style="list-style-type: none"> • Replace the ECM Is the replacement complete?		Go to Step (8)	-

Step	Action	Value(s)	Yes	No
8	<ul style="list-style-type: none"> • Remove all test equipment except the DST. • Connect any disconnected components, fuses, etc. • Using the DST clear DTC information from the ECM. • Turn the ignition OFF and wait 30 seconds. • Start the engine and operate the vehicle to full operating temperature • Observe the MIL • Observe engine performance and drivability • After operating the engine within the test parameters of DTC-1626 check for any stored codes. <p>Does the engine operate normally with no stored codes?</p>		System OK	Go to OBD System Check

DTC 1627-CAN Rx Failure (SPN 639:FMI 12)

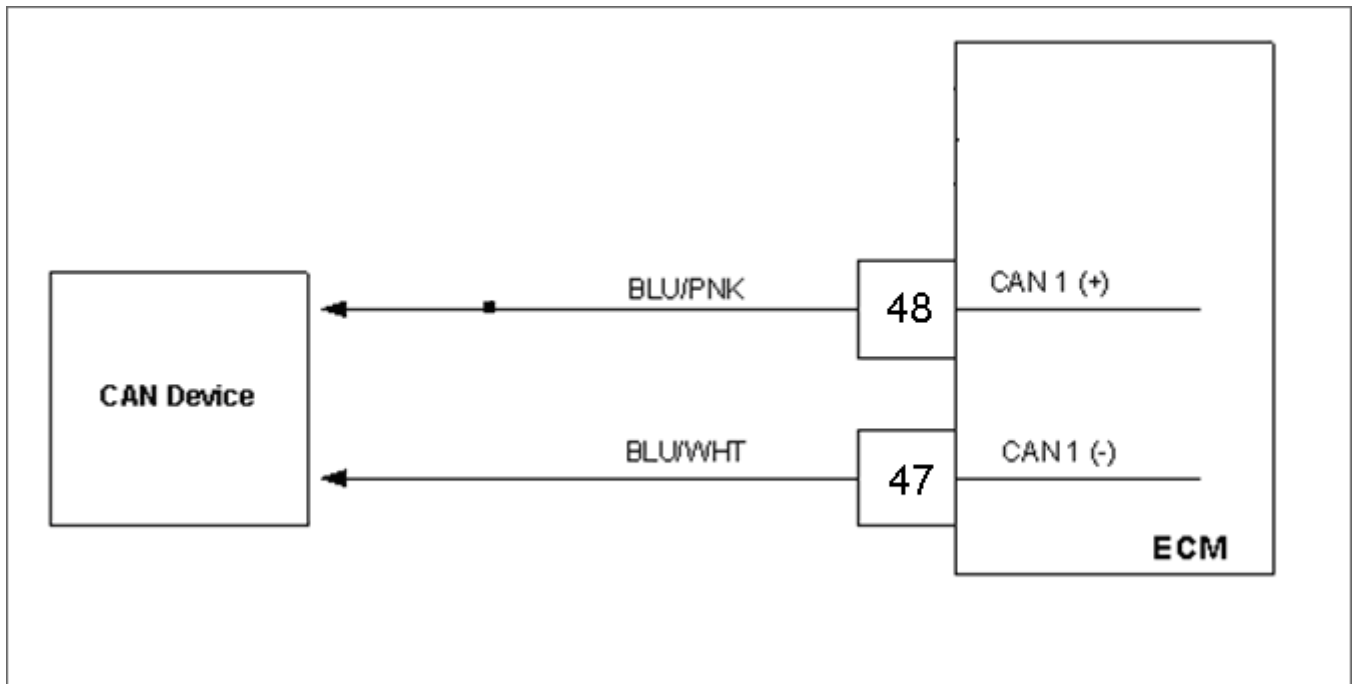

Conditions for Setting the DTC

- CAN Rx
- Check Condition-Engine running
- Fault Condition-CAN Rx error 120 packets lost within 1 second
- MIL-ON

Circuit description

The CAN bus (controller area network) is used by the ECM to communicate with other digital devices used throughout the fuel system. Information is sent over the CAN bus in digital information "packets" that contain information for various control functions. This fault will set if the ECM detects 120 packets lost within a one second time period. The MIL command is ON.

DTC 1627-CAN Rx Failure

Step	Action	Value(s)	Yes	No
1	Did you perform the On-Board (OBD) System Check?	-	Go to Step (2)	Go to OBD System Check Section
2	<ul style="list-style-type: none"> • Key ON, Engine Running • DST (Diagnostic Scan Tool) connected in System Data Mode • Clear system fault code Does DTC1627 reset with the engine idling?		Go to Step (3)	Intermittent problem Go to Intermittent section
3	<ul style="list-style-type: none"> • Check that the ECM power connection C019 is clean, tight and in the proper location. • Check that the ECM ground connection C010 is clean, tight and in the proper location. Are the power and ground circuits OK?		Go to Step (4)	Repair the circuit as necessary. Refer to Wiring Repairs in Engine Electrical.
4	<ul style="list-style-type: none"> • Using a DVOM check for continuity between ECM pins 47 and 48 Do you have continuity between them?		Repair the shorted circuit as necessary. Refer to Wiring Repairs in Engine Electrical.	Go to Step (5)
5	<ul style="list-style-type: none"> • Using a DVOM check for continuity to engine ground on pin 47. Do have continuity to engine ground?		Repair the shorted to ground circuit as necessary. Refer to Wiring Repairs in Engine Electrical.	Go to Step (6)
6	<ul style="list-style-type: none"> • Using a DVOM check for continuity to battery positive on pin 47. Do have continuity between them?		Repair the shorted to ground circuit as necessary. Refer to Wiring Repairs in Engine Electrical.	Go to Step (7)
7	<ul style="list-style-type: none"> • Replace the ECM Is the replacement complete?		Go to Step (8)	-

Step	Action	Value(s)	Yes	No
8	<ul style="list-style-type: none"> • Remove all test equipment except the DST. • Connect any disconnected components, fuses, etc. • Using the DST clear DTC information from the ECM. • Turn the ignition OFF and wait 30 seconds. • Start the engine and operate the vehicle to full operating temperature • Observe the MIL • Observe engine performance and drivability • After operating the engine within the test parameters of DTC-1627 check for any stored codes. <p>Does the engine operate normally with no stored codes?</p>		System OK	Go to OBD System Check

DTC 1628-CAN Address Conflict (SPN 639:FMI 13)

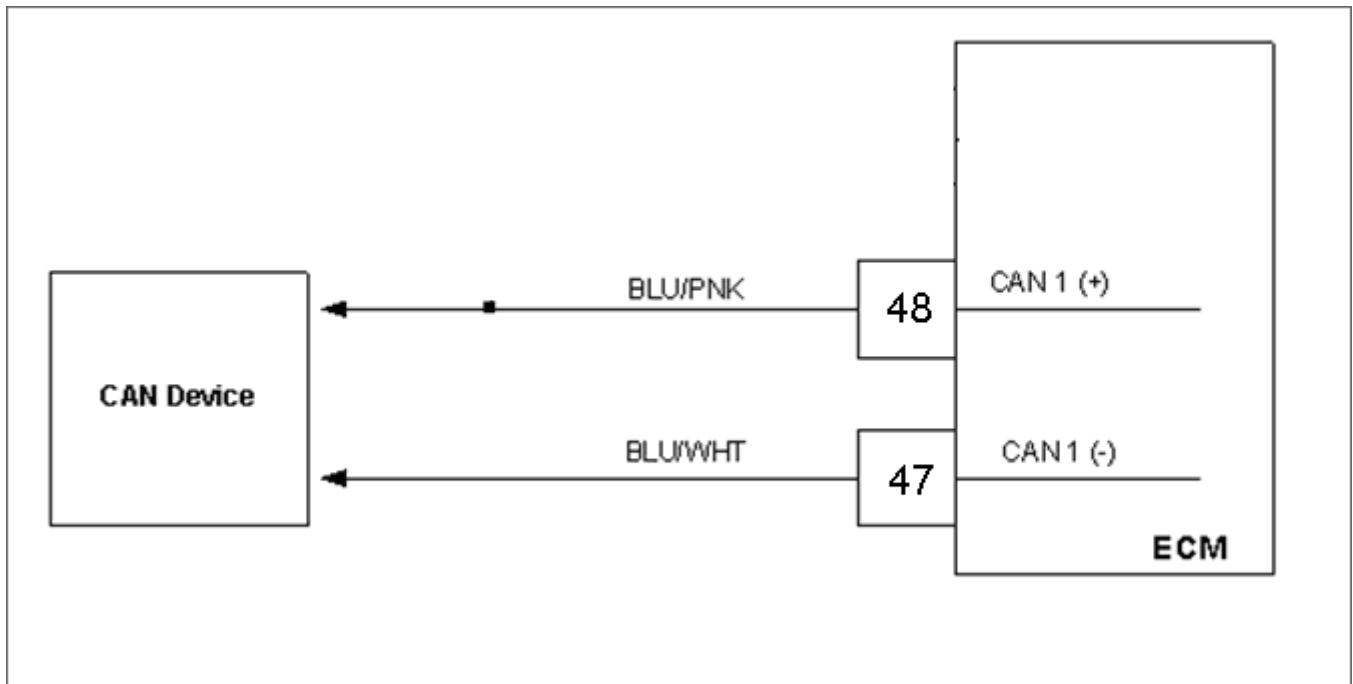

Conditions for Setting the DTC

- CAN Rx
- Check Condition-Engine running
- Fault Condition-5 or more address conflict errors
- MIL-ON

Circuit description

The CAN bus (controller area network) is used by the ECM to communicate with other digital devices used throughout the fuel system. Information is sent over the CAN bus in digital information "packets" that contain information for various control functions. Individual devices are assigned network addresses. This fault will set if the ECM detects an address conflict, such as two devices with the same address. This is usually not due to an in field failure and may be the results of "add on" CAN devices

DTC 1628-CAN Address Conflict

Step	Action	Value(s)	Yes	No
1	Did you perform the On-Board (OBD) System Check?	-	Go to Step (2)	Go to OBD System Check Section
2	<ul style="list-style-type: none"> • Key ON, Engine Running • DST (Diagnostic Scan Tool) connected in System Data Mode • Clear system fault code Does DTC1628 reset with the engine idling?		Go to Step (3)	Intermittent problem Go to Intermittent section
3	<ul style="list-style-type: none"> • Key OFF • Disconnect one CAN device • Clear DTC 1628 • Key ON (start engine if possible if not continue cranking for at least 3 seconds) • Wait 5 seconds Does DTC 1628 re-set?		Repeat step 3 until all CAN devices have been disconnected one at a time	Contact the CAN device manufacturer for additional CAN address information Go to Step (4)
4	Has the CAN device been replaced or address conflict resolved?		Go to Step (5)	-
5	<ul style="list-style-type: none"> • Remove all test equipment except the DST. • Connect any disconnected components, fuses, etc. • Using the DST clear DTC information from the ECM. • Turn the ignition OFF and wait 30 seconds. • Start the engine and operate the vehicle to full operating temperature • Observe the MIL • Observe engine performance and drivability • After operating the engine within the test parameters of DTC-1628 check for any stored codes. Does the engine operate normally with no stored codes?		System OK	Go to OBD System Check

DTC 2111-Unable to Reach Lower TPS (SPN 51:FMI 7)

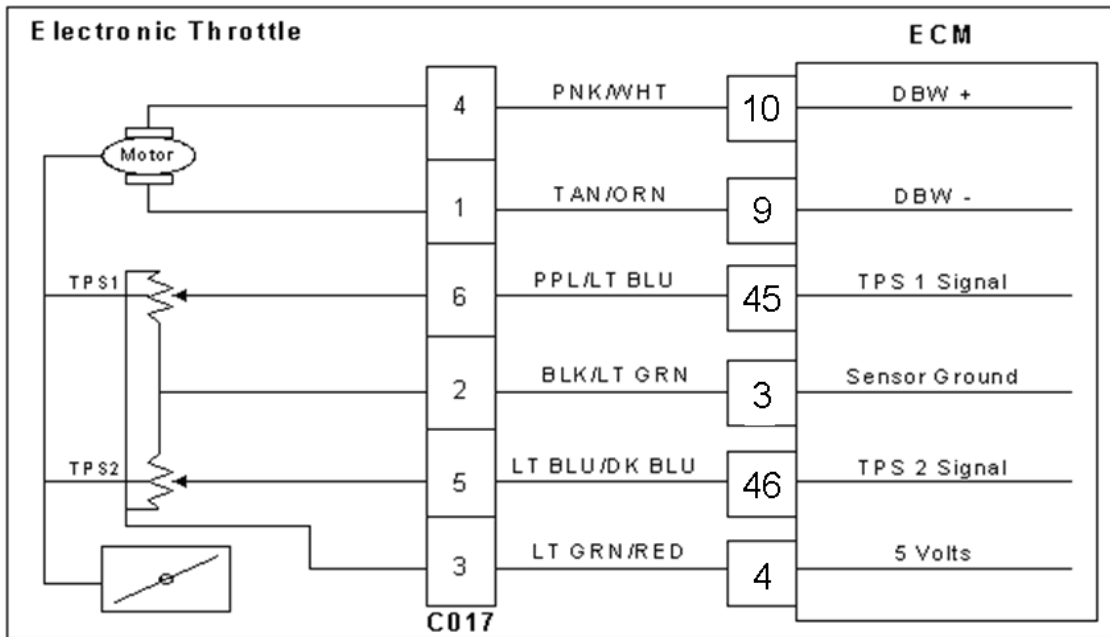

Conditions for Setting the DTC

- Throttle Position Sensor
- Check Condition-Cranking or Running
- Fault Condition-Actual throttle position is 20% greater than the throttle command
- MIL-ON during active fault
- Engine shutdown

Circuit Description

Dual throttle Position Sensors are used within the throttle that use variable resistors to determine signal voltage based on throttle plate position. TPS 1 will read low voltage when closed and TPS 2 will read high voltage when closed. The TPS 1 and TPS 2 percentages are calculated from these voltages. Although the voltages are different, the calculated values for the throttle position percentages should be very close to the same. The TPS values are used by the ECM to determine if the throttle is opening as commanded. This fault will set if the actual throttle position is 20% greater than the throttle command. During this active fault the MIL command is ON and the engine will shut down.

DTC 2111 Unable to Reach Lower TPS

Step	Action	Value(s)	Yes	No
1	Did you perform the On-Board (OBD) System Check?	-	Go to Step (2)	Go to OBD System Check Section
2	<ul style="list-style-type: none"> • Key ON, Engine OFF • DST (Diagnostic Scan Tool) connected in DBW (Drive By Wire) test mode • Depress foot pedal until the throttle command is between 63%-68% Is the TPS 1 voltage greater than 2.0 volts?		Go to Step (3)	Intermittent problem Go to Intermittent section
3	<ul style="list-style-type: none"> • Key OFF • Disconnect electronic throttle connector C017 • Probe TPS 1 signal pin 6 with a test light connected to battery voltage • Key ON Does DST display TPS 1 voltage less than 0.2 volts?		Go to Step (6)	Go to Step (4)
4	<ul style="list-style-type: none"> • Key OFF • Disconnect ECM wire harness connector C001 • Key ON • Using a DVOM check for voltage between throttle connector TPS 1 signal pin 6 and engine ground Do you have voltage?		Repair the circuit as necessary. Refer to Wiring Repairs in Engine Electrical.	Go to Step (5)
5	<ul style="list-style-type: none"> • Replace ECM Is the replacement complete?		Go to Step (13)	-
6	<ul style="list-style-type: none"> • Probe sensor ground circuit at ECM connector C001 with a test light connected to battery voltage Does the test light come on?		Go to Step (9)	Go to Step (7)
7	<ul style="list-style-type: none"> • Key OFF • Disconnect ECM wire harness connector C001 • Using a DVOM check for continuity between throttle connector signal ground pin 2 and ECM signal ground circuit pin 3 Do you have continuity between them?		Go to Step (8)	Repair the circuit as necessary. Refer to Wiring Repairs in Engine Electrical.
8	<ul style="list-style-type: none"> • Replace ECM Is the replacement complete?		Go to Step (13)	-
9	<ul style="list-style-type: none"> • Check throttle for foreign object in bore Did you find a foreign object in the bore?		Go to Step (10)	Go to Step (11)
10	<ul style="list-style-type: none"> • Remove foreign object Is the removal complete?		Go to Step (13)	-

Step	Action	Value(s)	Yes	No
11	<ul style="list-style-type: none"> Inspect the throttle wire harness connector terminals for damage, corrosion or contamination Did you find the problem?		Repair the circuit as necessary. Refer to Wiring Repairs in Engine Electrical.	Go to Step (12)
12	<ul style="list-style-type: none"> Replace throttle Is the replacement complete?		Go to Step (13)	-
13	<ul style="list-style-type: none"> Remove all test equipment except the DST. Connect any disconnected components, fuses, etc. Using the DST clear DTC information from the ECM. Turn the ignition OFF and wait 30 seconds. Start the engine and operate the vehicle to full operating temperature Observe the MIL Observe engine performance and drivability After operating the engine within the test parameters of DTC-2111 check for any stored codes. Does the engine operate normally with no stored codes?		System OK	Go to OBD System Check

DTC 2112-Unable to Reach Higher TPS (SPN 51:FMI 7)

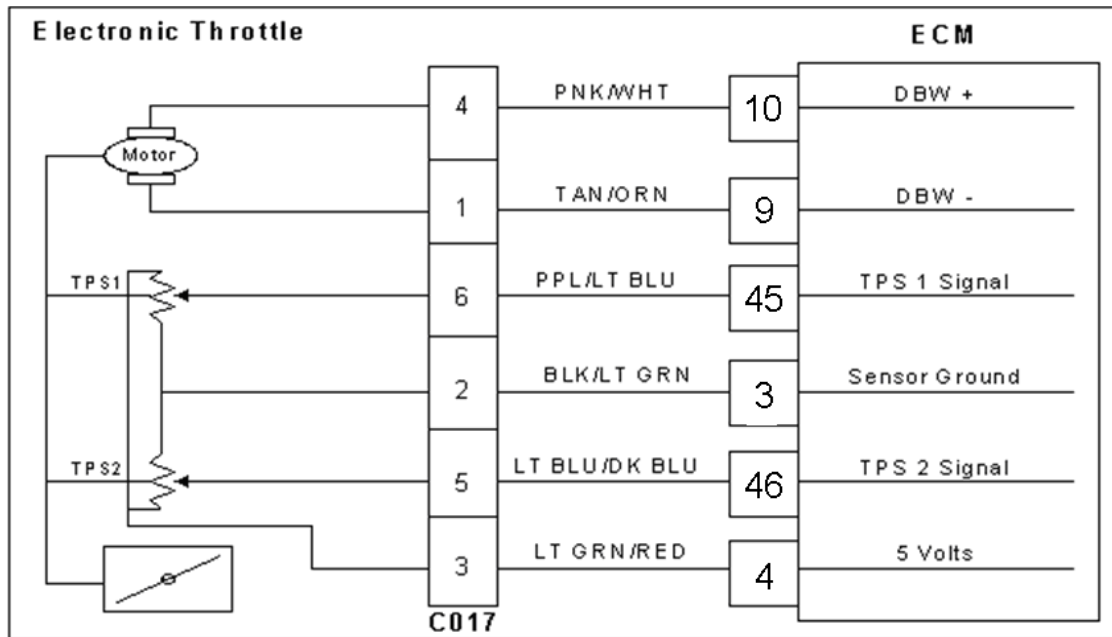

Conditions for Setting the DTC

- Throttle Position Sensor
- Check Condition-Cranking or Running
- Fault Condition-Actual throttle position is 20% less than the throttle command
- MIL-ON during active fault
- Engine shutdown

Circuit Description

Dual throttle Position Sensors are used within the throttle that use variable resistors to determine signal voltage based on throttle plate position. TPS 1 will read low voltage when closed and TPS 2 will read high voltage when closed. The TPS 1 and TPS 2 percentages are calculated from these voltages. Although the voltages are different, the calculated values for the throttle position percentages should be very close to the same. The TPS values are used by the ECM to determine if the throttle is opening as commanded. This fault will set if the actual throttle position is 20% less than the throttle command. The MIL command is ON and the engine will shut down.

DTC 2112-Unable to Reach Higher TPS

Step	Action	Value(s)	Yes	No
1	Did you perform the On-Board (OBD) System Check?	-	Go to Step (2)	Go to OBD System Check Section
2	<ul style="list-style-type: none"> • Key ON, Engine OFF • DST (Diagnostic Scan Tool) connected in DBW (Drive by Wire) test mode • Depress foot pedal until the throttle command is 63%-68% Is the TPS voltage less than 2.0 volts?		Go to Step (3)	Intermittent problem Go to Intermittent section
3	<ul style="list-style-type: none"> • Key OFF • Disconnect electronic throttle connector C017 • Probe TPS 1 signal circuit pin 6 with test light connected to battery voltage • Key ON Is TPS voltage 4.0 volts or greater?		Go to Step (4)	Go to Step (8)
4	<ul style="list-style-type: none"> • Check throttle bore for foreign object Did you find a problem?		Go to Step (5)	Go to Step (6)
5	<ul style="list-style-type: none"> • Remove the foreign object Has the object been removed?		Go to Step (11)	-
6	<ul style="list-style-type: none"> • Check the electronic throttle connector terminals for damage corrosion or contamination Did you find a problem?		Repair the circuit as necessary. Refer to Wiring Repairs in Engine Electrical.	Go to Step (7)
7	<ul style="list-style-type: none"> • Replace throttle Is the replacement complete?		Go to Step (11)	-
8	<ul style="list-style-type: none"> • Key OFF • Disconnect ECM wire harness connector C001 • Using a DVOM check for continuity between throttle connector TPS 1 signal pin 6 and ECM TPS 1 signal pin 45 Do you have continuity between them?		Go to Step (9)	Repair the circuit as necessary. Refer to Wiring Repairs in Engine Electrical.
9	<ul style="list-style-type: none"> • Using a DVOM check for continuity between throttle connector TPS 1 signal pin 6 and engine ground Do you have continuity between them?		Repair the shorted to ground circuit as necessary. Refer to Wiring Repairs in Engine Electrical.	Go to Step (10)
10	<ul style="list-style-type: none"> • Replace ECM Is the replacement complete?		Go to Step (11)	-

Step	Action	Value(s)	Yes	No
11	<ul style="list-style-type: none"> • Remove all test equipment except the DST. • Connect any disconnected components, fuses, etc. • Using the DST clear DTC information from the ECM. • Turn the ignition OFF and wait 30 seconds. • Start the engine and operate the vehicle to full operating temperature • Observe the MIL • Observe engine performance and drivability • After operating the engine within the test parameters of DTC-2112 check for any stored codes. <p>Does the engine operate normally with no stored codes?</p>		System OK	Go to OBD System Check

DTC 2135: TPS1/2 simultaneous voltages out-of-range **(SPN 51:FMI 31)**

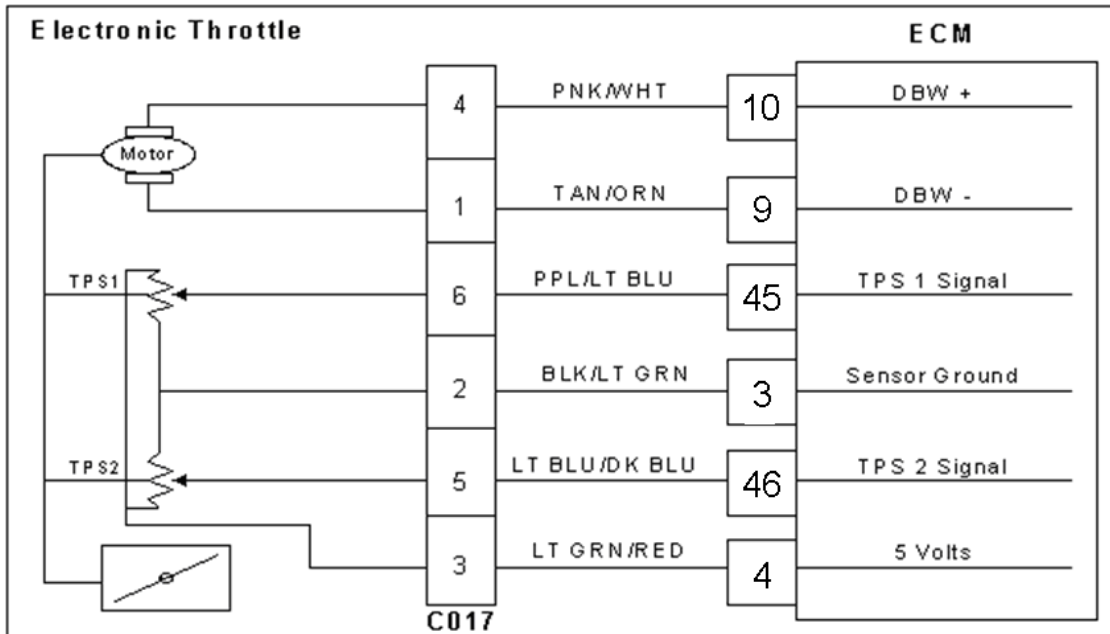

Conditions for Setting the DTC

- Throttle Position Sensor 1 & 2
- Check Condition-Key ON
- Fault Condition-TPS 1 20% higher than TPS2
- MIL-ON for remainder of key on cycle
- Engine shutdown

Circuit Description

Dual throttle Position Sensors are used within the throttle that use variable resistors to determine signal voltage based on throttle plate position. TPS 1 will read lower voltage when closed and TPS 2 will read higher voltage when closed. The TPS 1 and TPS 2 percentages are calculated from these voltages. Although the voltages are different, the calculated values for the throttle position percentages should be very close to the same. The TPS values are used by the ECM to determine if the throttle is opening as commanded. The TPS is not serviceable and in the event of a failure the electronic throttle assembly must be replaced. This fault will set if TPS 1 is 20% (or more) higher than TPS 2. At this point the throttle is considered to be out of specification, or there is a problem with the TPS signal circuit. The MIL command is ON and the engine will shut down.

DTC 2135: TPS1/2 simultaneous voltages out-of-range

Step	Action	Value(s)	Yes	No
1	Did you perform the On-Board (OBD) System Check?	-	Go to Step (2)	Go to OBD System Check Section
2	<ul style="list-style-type: none"> • Key ON, Engine OFF • DST (Diagnostic Scan Tool) connected in System Data Mode Does the DST display more than a 20% difference between TPS 1 and TPS 2?		Go to Step (3)	Intermittent problem Go to Intermittent section
3	<ul style="list-style-type: none"> • Key OFF • Disconnect electronic throttle connector C017 • Key ON • Change DST mode to DBW (drive by wire) test mode Is the voltage for TPS 1 less than 0.1 volts?		Go to Step (5)	Go to Step (4)
4	<ul style="list-style-type: none"> • Key OFF • Disconnect ECM wiring harness connector C001 • Key ON • Using a DVOM check for voltage between ECM connector TPS 1 signal pin 5 and engine ground Do you have voltage?		Repair the TPS 1 circuit shorted to voltage as necessary. Refer to Wiring Repairs in Engine Electrical.	Go to Step (9)
5	<ul style="list-style-type: none"> • Jump TPS 1 signal pin 6 to the 5-volt reference pin 3 at connector C017 Does DST display TPS 1 voltage over 4.900 volts?		Go to Step (6)	Go to Step (8)
6	<ul style="list-style-type: none"> • Inspect wire terminals at throttle connector for damage corrosion or contamination Any problems found?		Repair the circuit as necessary. Refer to Wiring Repairs in Engine Electrical.	Go to Step (7)
7	<ul style="list-style-type: none"> • Replace the electronic Throttle Is the replacement complete?		Go to Step (12)	-
8	<ul style="list-style-type: none"> • Key OFF • Disconnect ECM wire harness connector C001 • Using a DVOM check for continuity between throttle connector TPS 1 signal pin 6 and ECM connector TPS 1 signal pin 45 Do you have continuity between them?		Go to Step (9)	Repair the open circuit as necessary. Refer to Wiring Repairs in Engine Electrical.

Step	Action	Value(s)	Yes	No
9	<ul style="list-style-type: none"> Using a DVOM check for continuity between throttle connector signal ground pin 2 and ECM connector signal ground pin 3 Do you have continuity between them?		Go to Step (10)	Repair the open circuit as necessary. Refer to Wiring Repairs in Engine Electrical.
10	<ul style="list-style-type: none"> Inspect ECM connector terminals for damage corrosion or contamination. Any problems found?		Repair the circuit as necessary. Refer to Wiring Repairs in Engine Electrical	Go to Step (11)
11	<ul style="list-style-type: none"> Replace ECM Is the replacement complete?		Go to Step (12)	-
12	<ul style="list-style-type: none"> Remove all test equipment except the DST. Connect any disconnected components, fuses, etc. Using the DST clear DTC information from the ECM. Turn the ignition OFF and wait 30 seconds. Start the engine and operate the vehicle to full operating temperature Observe the MIL Observe engine performance and driveability After operating the engine within the test parameters of DTC-221 check for any stored codes. Does the engine operate normally with no stored codes?		System OK	Go to OBD System Check

DTC 2229-BP High Pressure (SPN 108:FMI 0)

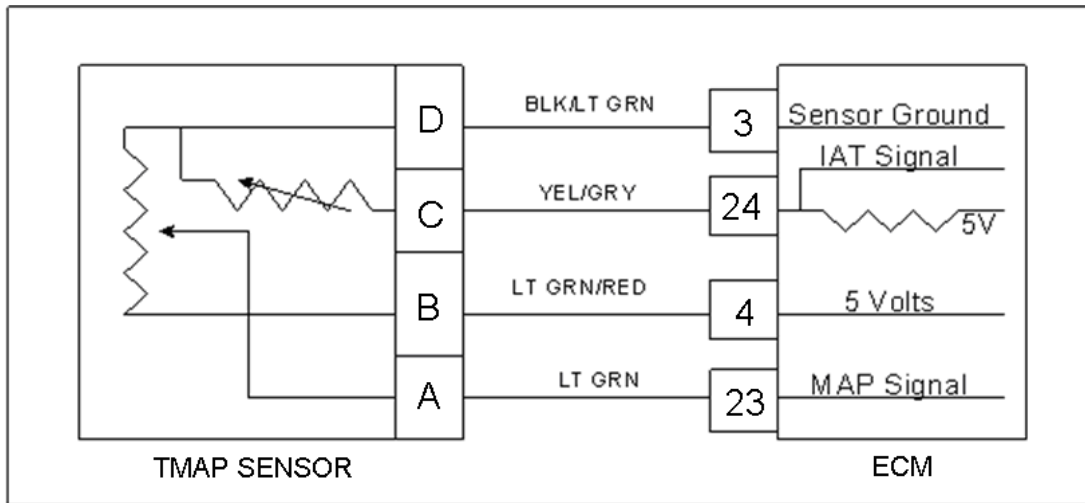

Conditions for Setting the DTC

- Barometric Pressure
- Check Condition-Key ON
- Fault Condition-BP greater than 16 psia
- MIL-ON for active fault
- Adaptive-Disabled

Circuit Description

The BP (Barometric Pressure) is estimated from the TMAP sensor. The barometric pressure value is used for fuel and airflow calculations. This fault sets in the event the BP value is out of the normal range.

DTC 2229-BP High Pressure

Step	Action	Value(s)	Yes	No
1	Did you perform the On-Board (OBD) System Check?	-	Go to Step (2)	Go to OBD System Check Section
2	<ul style="list-style-type: none"> • Key ON • DST (Diagnostic Scan Tool) connected in • System Data Mode Does DST display MAP pressure of 16 psia or greater?		Go to Step (3)	Intermittent problem Go to Intermittent section
3	<ul style="list-style-type: none"> • Replace TMAP sensor. Is the repair complete?		Go to Step 4	-
4	<ul style="list-style-type: none"> • Remove all test equipment except the DST. • Connect any disconnected components, fuses, etc. • Using the DST clear DTC information from the ECM. • Turn the ignition OFF and wait 30 seconds. • Start the engine and operate the vehicle to full operating temperature • Observe the MIL • Observe engine performance and driveability • After operating the engine within the test parameters of DTC-2229 check for any stored codes. Does the engine operate normally with no stored codes?		System OK	Go to OBD System Check

Definitions

Air Valve Vacuum (AVV): The vacuum signal taken from below the air valve assembly and above the throttle butterfly valve.

ADP: Adaptive Digital Processor.

Air/Fuel Ratio: The amount or balance of air and fuel in the air fuel mixture that enters the engine.

Analog Voltmeter: A meter that uses a mechanical needle to point to a value on a scale of numbers. It is usually of the low impedance type and used to measure voltage and resistance.

Aromatics: Pertaining to or containing the six-carbon ring characteristic of the benzene series. Found in many petroleum distillates.

Backfire: Combustion of the air/fuel mixture in the intake or exhaust manifolds. A backfire can occur if the intake or exhaust valves are open when there is a mis-timed ignition spark.

Benzene: An aromatic (C_6H_6). Sometimes blended with gasoline to improve anti-knock value. Benzene is toxic and suspected of causing cancer.

Bi-Fueled: A vehicle equipped to run on two fuels.

Blow-By: Gases formed by the combustion of fuel and air, which ordinarily should exert pressure only against the piston crown and first compression ring. When rings do not seal, these gases escape or "blow by" the side of the piston into the crankcase.

BTU: British Thermal Unit. A measurement of the amount of heat required to raise the temperature of 1lb. of water 1 degree F.

Butane: An odorless, colorless gas, C_4H_{10} found in natural gas and petroleum. One of the five LP gases.

CAFE: Corporate Average Fuel Economy.

CARB: California Air Resources Board.

Carbon Monoxide (CO): A chemical compound of a highly toxic gas that is both odorless and colorless.

Carburetor: An apparatus for supplying an internal-combustion engine a mixture of vaporized fuel and air.

Cathode Ray Tube: A vacuum tube in which cathode rays usually in the form of a slender beam are projected on a fluorescent screen and produce a luminous spot.

Circuit: A path of conductors through which electricity flows.

Closed Loop Operation: Applies to systems utilizing an oxygen sensor. In this mode of operation, the system uses oxygen sensor information to determine air/fuel ratio. Adjustments are made accordingly and checked by comparing the new oxygen sensor to previous signals. No stored information is used.

CNG: Compressed Natural Gas.

CKP: Crankshaft Position Sensor

CMP: Camshaft Position Sensor

Conductor: A material, normally metallic, that permits easy passage of electricity.

Contaminants: Impurities or foreign material present in fuel.

Control Module: One of several informal names for a solid state microcomputer which monitors engine conditions and controls certain engine functions; i.e. air/fuel ratio, injection and ignition time, etc. The formal name and the one used throughout this manual is ECM, or Engine Control Module.

Converter: A LPG fuel system component containing varying stages of fuel pressure regulation combined with a vaporizer.

Cryogen: A refrigerant used to obtain very low temperatures.

Current: The volume or flow of electrons through a conductor. Measured in amperes or amps.

DBW: Drive By Wire

Dedicated Fuel System: A motor fuel system designed to operate on only one fuel type.

Diaphragm: A thin, flexible membrane that separates two chambers. When the pressure in one chamber is lower than in the other chamber, the diaphragm will move toward the side with the low pressure.

Diaphragm Port: The external port located at the fuel inlet assembly and connected to the vacuum chamber above the air valve diaphragm.

DLC: Data Link Connector.

DTC: Diagnostic Trouble Code

DST: Diagnostic Scan Tool.

DVOM: Digital Volt/ohm Meter. A meter that uses a numerical display in place of a gauge and is usually of the high impedance type.

ECT: Engine Coolant Temperature.

ECM: Electronic Control Module

ECOM: A DLC cable supporting CAN and serial communication with a PSI/EControls ECM.

EFI: Electronic Fuel Injection. A fuel injection system, which uses a microcomputer (ECM) to determine and control the amount of fuel, required by, and injected into, a particular engine.

EGO: Exhaust Gas Oxygen, used to describe a sensor. Also known as "HEGO" (Heat Exhaust Gas Oxygen) sensor, "O2" or "Oxygen sensor."

EGR: Exhaust Gas Recirculation.

EPA: Environmental Protection Agency: A regulating agency of the Federal government which, among other duties, establishes and enforces automotive emissions standards.

Ethanol: Grain alcohol (C_2H_5OH), generally produced by fermenting starch or sugar.

Evaporative Emissions Controls: An automotive emission control system designed to reduce hydrocarbon emissions by trapping evaporated fuel vapors from the fuel system.

Excess Flow Valve: A check valve that is caused to close by the fuel when the flow exceeds a pre-determined rate.

FTV: Fuel Trim Valve.

FFV: Flexible Fuel Vehicle.

Firing Line: The portion of an oscilloscope pattern that represents the total amount of voltage being expended through the secondary circuit.

FMVSS: Federal Motor Vehicle Safety Standards.

FPP: Foot Pedal Position Sensor

Fuel Injector: A spring loaded, electromagnetic valve which delivers fuel into the intake manifold, in response to an electrical input from the control module.

Fuel Lock: A solenoid-controlled valve located in the fuel line to stop the flow when the engine stops or the ignition switch is off.

Gasohol: 10 percent ethanol, 90 percent gasoline. Often referred to as E-10.

Gasoline: A motor vehicle fuel that is a complex blend of hydrocarbons and additives. Typical octane level is 89.

GCP: Spectrum III (90-pin) ECM.

Greenhouse Effect: A scientific theory suggesting that carbon dioxide from the burning of fossil fuels is causing the atmosphere to trap heat and cause global warming.

HC: Hydrocarbon. An organic chemical compound.

HD 10: A fuel of not less than 80% liquid volume propane and not more than 10% liquid volume propylene.

HD 5: A fuel of not less than 90% liquid volume propane and not more than 5% liquid volume propylene.

HDV: Heavy Duty Vehicle.

Heavy Ends: A term used to describe the build up of wax-like impurities that fall out of LPG when vaporized.

HEGO: Heated Exhaust Gas Oxygen, used to describe a sensor. Also known as "EGO" (Exhaust Gas Oxygen sensor), "O₂" or "Oxygen sensor.

Hg: Chemical symbol for the element mercury. Used in reference to a measure of vacuum (inches of Hg).

Histogram: The graphical version of a table which shows what proportion of values fall into specific categories over a specific period of time.

Hydrocarbon: A chemical compound made up of hydrogen and carbon (HC). Gasoline and almost all other fuels are hydrocarbons.

Hydrostatic Relief Valve: A pressure relief device installed in the liquid LPG hose on a LPG fuel system.

IAT: Intake Air Temperature

Ideal Mixture: The air/fuel ratio at which the best compromise of engine performance to exhaust emissions is obtained. Typically, 14.7:1.

Ignition Reserve: The difference between available voltage and the required voltage.

ILEV: Inherently Low Emission Vehicle.

Impedance: A form of opposition of AC electrical current flow (resistance) measured in ohms.

Insulation: A nonconductive material used to cover wires in electrical circuits to prevent the leakage of electricity and to protect the wire from corrosion.

Intercept: An electrical term for a type of splice where the original circuit is interrupted and redirected through another circuit.

Knock: Sound produced when an engine's air/fuel mixture is ignited by something other than the spark plug, such as a hot spot in the combustion chamber. Also caused by a fuel with an octane rating that is too low and/or incorrect ignition timing. Also called detonation or ping.

Lambda Sensor: A feedback device, usually located in the exhaust manifold, which detects the amount of oxygen present in exhaust gases in relation to the surrounding atmosphere. (See HEGO).

LDV: Light Duty Vehicle.

Lean Mixture: An air to fuel ratio above the stoichiometric ratio; too much air.

LEV: Low Emission Vehicle.

Limp-in or Limp Home: A mode where the ECM or a component has failed, but the vehicle remains operational although the engine may operate minimally. This term may also describe the drivability characteristics of a failed computer system.

Liquid Petroleum Gas (LPG): A fuel commonly known as propane consisting mostly of propane (C_3H_8), derived from the liquid components of natural gas stripped out before the gas enters the pipeline, and the lightest hydrocarbons produced during petroleum refining. Octane level of LPG is 107.

LPG: Liquefied Petroleum Gas.

M85: A blend of gasoline and methanol consisting of 85% methanol and 15% gasoline.

Measurements of Pressure: 1 PSI=2.06" Hg (mercury) = 27.72" H₂O (water column). At sea level atmospheric pressure is 29.92" Hg.

Methanol: Known as wood alcohol (CH₃OH), a light, volatile, flammable alcohol commonly made from natural gas.

MIL: Malfunction Indicator Lamp.

Misfire: Failure of the air/fuel mixture to ignite during the power stroke.

Mixer: Fuel introduction device that does not include a throttle plate.

MFI: Multiport Fuel Injection. A fuel injection system that uses one injector per cylinder mounted on the engine to spray fuel near the intake valve area of combustion chamber.

MSV: Manual Shut-Off Valve. Refers to the manually operated valve on the LPG tank.

MTBE: Methyl Tertiary Butyl Ether. Oxygenate add to gasoline to reduce harmful emissions and to improve the octane rating.

Multi-fuel System: A motor fuel system designed to operate on two different fuels, such as LPG and gasoline.

Natural Gas: A gas formed naturally from buried organic material, composed of a mixture of hydrocarbons, with methane (CH₄) being the dominant component.

NGV: Natural Gas Vehicle.

NOX: See Oxides of Nitrogen.

OBD: On Board Diagnostic

Octane Rating: The measurement of the antiknock value of a motor fuel.

OEM: Original Equipment Manufacturer, the vehicle manufacturer.

Open-Loop: An operational mode during which control module memory information is used to determine air/fuel ratio, injection timing, etc., as opposed to actual oxygen sensor input.

Orifice: A port or passage with a calibrated opening designed to control or limit the amount of flow through it.

Oscilloscope: An instrument that converts voltage and frequency readings into traces on a cathode ray tube (also see Cathode Ray Tube).

Oxides of Nitrogen: Chemical compounds of nitrogen bonded to various amounts of oxygen (NOX). A chief smog forming-agent.

Oxygen Sensor: An automotive fuel system that produces a signal in accordance with the oxygen content of the exhaust gas. (See Lambda Sensor).

Oxygenate: Oxygenates (such as MTBE, ethanol and methanol) added to gasoline to increase the oxygen content and therefore reduce exhaust emissions.

Ozone: A radical oxygen molecule (O₃) that is found in the upper atmosphere and filters out ultraviolet radiation from the sun. Ground level ozone is formed by NOX, during the formation of photo-chemical smog.

Particulates: Microscopic pieces of solid or liquid substances such as lead and carbon that are discharged into the atmosphere by internal combustion engines.

Positive Crankcase Ventilation (PCV): An automotive emission control system designed to reduce hydrocarbon emissions by routing crankcase fumes into the intake manifold rather than to the atmosphere.

Power Derate: A mode of reduced engine power output for the purposes of protecting engine components during a failure or malfunction.

Pressure Differential: The differential between atmospheric pressure and intake manifold (referred to as vacuum) pressure.

Pressure Regulator: A device to control the pressure of fuel delivered to the fuel injector(s).

Primary Circuit: The low-voltage or input side of the ignition coil.

Propane: An odorless and colorless gas, C₃H₈, found in natural gas and petroleum.

Psia: pounds per square inch absolute

PTV: Pressure Trim Valve

Reactivity: Refers to the tendency of an HC in the presence of NOX and sunlight to cause a smog-forming reaction. The lighter the HC, the lower reactivity tends to be.

Regulator: An assembly used to reduce and control the pressure of a liquid or vapor.

Resistance: The opposition to the flow of current in an electrical circuit. Measured in ohms.

Rest Pressure: Fuel pressure maintained within the system after engine shutdown.

Rich Mixture: An air to fuel ratio below the stoichiometric ratio; too much fuel.

SAE: Society of Automotive Engineers.

Secondary Circuit: The high-voltage output side of the ignition coil.

SEFI or SFI: Sequential Electronic Fuel Injection or Sequential Fuel Injection.

Sensors: Devices that provide the control module with engine information as needed to properly control engine function.

Spark Line: The portion of an oscilloscope pattern that represents the time during which the air/fuel mixture is being burned in the combustion chamber.

Splice: An electrical term for the joining of two or more conductors at a single point.

Stoichiometric Ratio: An ideal fuel/air ratio for combustion in which all of the fuel and most of the oxygen will be burned.

Sulfur Oxides: Chemical compounds where sulfur is bonded to oxygen produced by the combustion of gasoline or any other fuel that contains sulfur. As sulfur oxides combine with water in the atmosphere to form sulfuric acid.

System Pressure: The fuel pressure maintained in the system during normal engine operation.

Tap: An electrical term for a type of splice where the original circuit is not interrupted.

TBI: Throttle Body Injection. Any of several injection systems that have the fuel injector(s) mounted in a centrally located throttle body.

Throttle Body: Controls engine RPM by adjusting the engine manifold vacuum to the mixer. Consists of a housing shaft, throttle liner and butterfly valve.

TLEV: Transitional Low Emission Vehicle.

TMAP: Combined Air Inlet and Manifold Pressure Sensor.

Toluene: A liquid aromatic hydrocarbon C_7H_8 .

TPS: Throttle Position Sensor.

TSB: Technical Service Bulletin.

ULEV: Ultra Low Emission Vehicle.

USB: Universal Serial Bus. A plug or interface supplied on most personal computers.

Vaporization: A process in which liquid changes states into gas.

Venturi Air Valve Vacuum (VAVV): An amplified air valve vacuum signal coming from the venturi area of the mixer, directly exposed to airflow before the addition of vaporized LPG.

Volt/ohmmeter (VOM): A combination meter used to measure voltage and resistance in an electrical circuit. Available in both analog and digital types. May also referred to as AVOM and DVOM.

Voltage: The electrical pressure that causes current to flow in a circuit. Measured in volts.

Voltage Drop: A lowering of the voltage in a circuit when resistance or electrical load is added.

Voltmeter: A meter that uses a needle to point to a value on a scale of numbers usually of the low impedance type; used to measure voltage and resistance.

VSS: Vehicle Speed Sensor

Xylene: $C_6H_4(CH_3)_2$. Any of three toxic, flammable, and oily isomeric aromatic hydrocarbons that are dimethyl homologues of benzene and usually obtained from petroleum or natural gas distillates.

ZEV: Zero Emission Vehicle.



**POWER SOLUTIONS
INTERNATIONAL**

**Power Solutions International, Inc (PSI)
201 Mittel Drive
Wood Dale, IL 60191
USA
630-350-9400**