



**POWER SOLUTIONS
INTERNATIONAL**

**PSI 40L
DIAGNOSTIC
MANUAL**

**LARGE SPARK
IGNITION**

This publication may not be reproduced without written permission of Power Solutions International (PSI). At date of publication, all information included in this manual is accurate to the best of our knowledge. PSI cannot be held responsible for information that has changed after publication date.

**Power Solutions International, Inc (PSI)
201 Mittel Drive
Wood Dale, IL 60191
USA
630-350-9400**

REVISION CONTROL INFORMATION

| Revision | Release Date | Change Description (s) |
|-----------------|---------------------|---|
| 1 | XX/XX/2024 | Initial Release |
| 2 | 05/20/2024 | Updated DTC list and DTC's. Added MFG information and DTCs. New Cover. |
| 3 | 12/09/2024 | Updated DTC 186, 187 and 188 information to reflect J1939 communication is used for sensor to ECM data transmission |
| | | |
| | | |
| | | |
| | | |
| | | |
| | | |
| | | |
| | | |
| | | |
| | | |
| | | |
| | | |

Table of Contents

| | |
|---|----|
| DIAGNOSTIC TROUBLE CODE (DTC) CHART..... | 7 |
| OBD System Check/MIL (Malfunction Indicator Lamp) | 10 |
| DTC 16 - Never Crank Synced at Start | 11 |
| DTC 107 - MAP Low Voltage | 12 |
| DTC 108 - MAP High Pressure | 15 |
| DTC 111 - IAT Higher Than Expected Stage 1..... | 17 |
| DTC 112 - IAT Low Voltage | 18 |
| DTC 113 - IAT High Voltage | 20 |
| DTC 116 - ECT Higher Than Expected 1 | 22 |
| DTC 117 - ECT/CHT Low Voltage | 24 |
| DTC 118 - ECT/CHT High Voltage | 26 |
| DTC 121 - TPS 1 Lower Than TPS 2 | 28 |
| DTC 122 - TPS 1 Low Voltage | 30 |
| DTC 123 - TPS 1 High Voltage..... | 33 |
| DTC 127 - IAT Higher Than Expected 2..... | 36 |
| DTC 129 - BP Low Pressure..... | 38 |
| DTC 148 - Fuel Run-out Longer Than Expected | 41 |
| DTC 154 - EGO2 Open/Lazy | 44 |
| DTC 186 - (3468:1) - FT Gaseous Fuel Extremely Low..... | 47 |
| DTC 187 - Fuel Temperature Gaseous Low..... | 48 |
| DTC 188 - (520240:3) - FT Gaseous Fuel High | 50 |
| DTC 217 - ECT Higher Than Expected 2 | 52 |
| DTC 221 - TPS 1 Higher Than TPS 2..... | 54 |
| DTC 222 - TPS 2 Signal Voltage Low | 57 |
| DTC 223 - TPS 2 Signal Voltage High..... | 60 |
| DTC 236 - TIP/TOP Active..... | 64 |
| DTC 237 - TIP/TOP Low Voltage..... | 65 |
| DTC 238 - TIP/TOP High Voltage | 68 |
| DTC 326 - Knock 1 Excessive Signal | 70 |
| DTC 327 - Knock 1 Sensor Open | 72 |
| DTC 336 - Crank Sync Noise | 74 |
| DTC 337 - Loss of Crankshaft Signal | 78 |
| DTC 341 - Cam Input Signal Noise | 79 |
| DTC 342 - Loss of Camshaft Input Signal..... | 83 |
| DTC 520 - Oil Pressure Low Stage 1..... | 84 |
| DTC 522 - Oil Pressure Sender low voltage | 87 |
| DTC 523 - Oil Pressure Sender high voltage | 89 |
| DTC 524 - Oil Pressure Low Stage 2..... | 92 |
| DTC 562 - System Voltage Low | 95 |

| | |
|--|-----|
| DTC 563 - Battery Voltage High | 97 |
| DTC 601 - Flash Checksum Invalid..... | 99 |
| DTC 604 - RAM Failure | 101 |
| DTC 606 - COP Failure..... | 103 |
| DTC 642 - External 5 Volt 1 Reference Low | 105 |
| DTC 643 - External 5 Volt 1 Reference High | 107 |
| DTC 685 - Relay Coil Open..... | 109 |
| DTC 686 - Relay Control Ground Short | 111 |
| DTC 687 - Relay Coil Short to Power..... | 113 |
| DTC 726 - Max Govern Speed Override..... | 115 |
| DTC 1111 - Fuel Rev Limit | 117 |
| DTC 1112 - Spark Rev Limit..... | 119 |
| DTC 1151 - Closed Loop High LPG | 121 |
| DTC 1152 - Closed Loop Multiplier Low LPG..... | 122 |
| DTC 1153 - Closed Loop Multiplier High NG | 123 |
| DTC 1154 - Closed Loop Multiplier Low NG | 125 |
| DTC 1161 - Adaptive Learn High LPG..... | 126 |
| DTC 1162 - Adaptive Learn Low LPG | 127 |
| DTC 1163 - Adaptive Learn High NG | 128 |
| DTC 1164 - Adaptive Learn Low NG..... | 129 |
| DTC 1271 - EPR Secondary Regulation Pressure Higher Than Expected..... | 130 |
| DTC 1272 - EPR Secondary Regulation Pressure Lower Than Expected..... | 132 |
| DTC 1325 - Knock Retard at Limit..... | 134 |
| DTC 1326 - Knock Retard Above Threshold..... | 136 |
| DTC 1330 - Intake Backfire Detected..... | 137 |
| DTC 1351 - Spark Plug or Coil Failure | 143 |
| DTC 1439 - Engine Oil Temperature Sensor High | 144 |
| DTC 1572 - AUX DIG4 high - Coolant Level Stage 1 High Voltage..... | 145 |
| DTC 1574 - AUX DIG5 high - Coolant Level Stage 2 High Voltage..... | 147 |
| DTC 1602 - Relay Off High Voltage | 149 |
| DTC 1603 - Relay On Low Voltage | 151 |
| DTC 1612 - RTI 1 Loss | 153 |
| DTC 1613 - RTI 2 Loss | 155 |
| DTC 1614 - RTI 3 Loss | 157 |
| DTC 1615 - A/D Loss..... | 159 |
| DTC 1616 - Invalid Interrupt | 161 |
| DTC 1625 - J1939 Shutdown Request..... | 163 |
| DTC 1626 - CAN1 Tx Failure | 164 |
| DTC 1627 - CAN1 Rx Failure..... | 165 |
| DTC 1628 - CAN Address Conflict | 168 |

| | |
|--|-----|
| DTC 1646 - CAN2 Tx Failure | 170 |
| DTC 1648 - CAN2 Rx Failure..... | 171 |
| DTC 1650 – CAN2 Address Conflict Failure | 172 |
| DTC 1673 - Calibration Configuration Error | 173 |
| DTC 1674 - Hardware ID Failure | 174 |
| DTC 2111 - Unable To Reach Lower TPS | 176 |
| DTC 2112 - Unable To Reach Higher TPS | 179 |
| DTC 2135 - TPS1/2 Simultaneous Voltages Out of Range | 182 |
| DTC 2229 - BP High Pressure | 183 |
| DTC 3031 - UEGO1 Heater Open/Ground Short | 185 |
| DTC 3032 - UEGO1 Heater Short to Power..... | 187 |
| DTC 8901 - UEGO1 Internal Processor Fault..... | 189 |
| DTC 8902 - UEGO1 Heater Supply High Voltage | 190 |
| DTC 8904 - UEGO1 Internal Supply Voltage Low | 192 |
| DTC 8910 - UEGO1 Sense Cell Voltage High | 193 |
| DTC 8914 - UEGO1 Sense Cell Slow to Warm Up..... | 195 |
| DTC 8916 - UEGO1 Sense Cell Impedance High | 196 |
| DTC 8920 - UEGO1 Internal Supply Voltage Low | 198 |
| Definitions..... | 199 |
| Connecting to Each ECM | 205 |
| MFG Valve Operation & Diagnostics | 206 |
| Mass Fuel Gas (MFG) Diagnostic Trouble Codes | 212 |
| DTC 101A - MFG Main Comm Lost | 213 |
| DTC 101B - MFG Internal Circuitry Fault Detection | 214 |
| DTC 102A - MFG Delta Pressure zVoltage High | 215 |
| DTC 102B - MFG Delta Pressure zVoltage High | 217 |
| DTC 102C - MFG Delta Pressure Voltage High | 220 |
| DTC 102D - MFG Delta Pressure Voltage Low | 223 |
| DTC 102E - MFG Delta Pressure Voltage Low | 226 |
| DTC 103C - MFG RLV Test Failed..... | 228 |
| DTC 1020 - MFG Unable to Reach Higher TPS | 229 |
| DTC 1022 - MFG Supply Voltage High | 230 |
| DTC 1023 - MFG Supply Voltage Low..... | 232 |
| DTC 1024 - MFG Fluid Temperature Voltage High | 234 |
| DTC 1025 - MFG Fluid Temperature Voltage Low | 236 |
| DTC 1026 - MFG Upstream Pressure Voltage High | 238 |
| DTC 1027 - MFG Upstream Pressure Voltage Low..... | 240 |
| DTC 1028 - MFG Downstream Pressure Voltage High | 242 |
| DTC 1029 - MFG Downstream Pressure Voltage Low | 244 |
| Pro-Lube Electrical Diagrams | 246 |

DIAGNOSTIC TROUBLE CODE (DTC) CHART

| DESCRIPTION | DTC | SPN | FMI |
|--|-----|--------|-----|
| Never crank synced at start | 16 | 636 | 8 |
| MAP low voltage | 107 | 106 | 4 |
| MAP high pressure | 108 | 106 | 16 |
| IAT higher than expected 1 | 111 | 105 | 15 |
| IAT low voltage | 112 | 105 | 4 |
| IAT high voltage | 113 | 105 | 3 |
| ECT higher than expected 1 | 116 | 110 | 15 |
| ECT / CHT low voltage | 117 | 110 | 4 |
| ECT / CHT high voltage | 118 | 110 | 3 |
| TPS1 lower than TPS2 | 121 | 51 | 1 |
| TPS1 low voltage | 122 | 51 | 4 |
| TPS1 high voltage | 123 | 51 | 3 |
| IAT higher than expected 2 | 127 | 105 | 0 |
| BP low pressure | 129 | 108 | 1 |
| Fuel run-out longer than expected | 148 | 1239 | 7 |
| EGO 2 Open / Lazy | 154 | 520208 | 10 |
| FT gaseous fuel extremely low | 186 | 3468 | 1 |
| FT gaseous fuel low | 187 | 520240 | 4 |
| FT gaseous fuel high | 188 | 520240 | 3 |
| ECT higher than expected 2 | 217 | 110 | 0 |
| RPM higher than expected | 219 | 515 | 31 |
| TPS2 low voltage | 222 | 3673 | 4 |
| TPS2 high voltage | 223 | 3673 | 3 |
| TIP/TOP active | 236 | 1692 | 2 |
| TIP/TOP low voltage | 237 | 1127 | 4 |
| TIP/TOP high voltage | 238 | 1127 | 3 |
| Knock excessive signal | 326 | 731 | 2 |
| Knock sensor open | 327 | 731 | 4 |
| Crank sync noise | 336 | 636 | 2 |
| Crank loss | 337 | 636 | 4 |
| Cam sync noise | 341 | 723 | 2 |
| Cam1 loss (intake) | 342 | 723 | 4 |
| Oil pressure low stage 1 (sender) | 520 | 100 | 18 |
| Oil pressure low voltage (switch or sender) | 522 | 100 | 4 |
| Oil pressure high voltage (switch or sender) | 523 | 100 | 3 |
| Oil pressure low stage 2 (sender) | 524 | 100 | 1 |

| DESCRIPTION | DTC | SPN | FMI |
|--|------|--------|-----|
| Voltage low | 562 | 168 | 17 |
| Voltage high | 563 | 168 | 15 |
| Flash checksum invalid | 601 | 628 | 13 |
| RAM failure | 604 | 630 | 12 |
| COP failure | 606 | 629 | 31 |
| 5VE1 low voltage | 642 | 1079 | 4 |
| 5VE1 high voltage | 643 | 1079 | 3 |
| Relay coil open | 685 | 1485 | 5 |
| Relay control ground short | 686 | 1485 | 4 |
| Relay coil short to power | 687 | 1485 | 3 |
| Max govern speed override | 726 | 515 | 15 |
| Fuel rev limit | 1111 | 515 | 16 |
| Spark rev limit | 1112 | 515 | 0 |
| CL high LPG (Closed Loop High LPG) | 1151 | 520206 | 0 |
| CL low LPG (Closed Loop Low LPG) | 1152 | 520206 | 1 |
| CL high NG (Closed Loop High NG) | 1153 | 520207 | 0 |
| CL low NG (Closed Loop Low NG) | 1154 | 520207 | 1 |
| AL high LPG (Adaptive Learn High LPG) | 1161 | 520202 | 0 |
| AL low LPG (Adaptive Learn Low LPG) | 1162 | 520202 | 1 |
| AL high NG (Adaptive Learn High NG) | 1163 | 520203 | 0 |
| AL low NG (Adaptive Learn Low NG) | 1164 | 520203 | 1 |
| EPR secondary regulation pressure higher than expected | 1271 | 520621 | 0 |
| EPR secondary regulation pressure lower than expected | 1272 | 520261 | 1 |
| Knock retard at limit | 1325 | 731 | 15 |
| Knock retard above threshold | 1326 | 731 | 15 |
| Intake backfire detected | 1330 | 520390 | 31 |
| Spark Plug or Coil Failure | 1351 | 1268 | 11 |
| AUX Temperature 1 high | 1439 | 1385 | 3 |
| AUX DIG4 high - Coolant Level Stage 1 High Voltage | 1572 | 716 | 3 |
| AUX DIG5 high - Coolant Level Stage 2 High Voltage | 1574 | 520202 | 0 |
| Relay off high voltage | 1602 | 1485 | 1 |
| Relay on low voltage | 1603 | 1485 | 31 |
| RTI 1 loss | 1612 | 629 | 31 |
| RTI 2 loss | 1613 | 629 | 31 |
| RTI 3 loss | 1614 | 629 | 31 |
| A/D loss | 1615 | 629 | 31 |
| Invalid interrupt | 1616 | 629 | 31 |
| Shutdown Request | 1625 | 1384 | 12 |

| DESCRIPTION | DTC | SPN | FMI |
|--|------|--------|-----|
| CAN1 Tx failure | 1626 | 639 | 12 |
| CAN1 Rx failure | 1627 | 639 | 13 |
| CAN1 address conflict failure | 1628 | 639 | 12 |
| CAN2 Tx failure | 1646 | 1231 | 12 |
| CAN2 Rx failure | 1648 | 1231 | 13 |
| CAN2 address conflict failure | 1650 | 1231 | 13 |
| Calibration Configuration Error | 1673 | 1634 | 2 |
| Hardware ID Failure | 1674 | 1634 | 7 |
| Unable to reach lower TPS | 2111 | 3673 | 7 |
| Unable to reach higher TPS | 2112 | 51 | 31 |
| TPS1/2 simultaneous voltages | 2135 | 51 | 0 |
| BP high pressure | 2229 | 108 | 4 |
| UEGO1 heater open / ground short | 3031 | 3222 | 3 |
| UEGO1 heater short to power | 3032 | 3222 | 31 |
| UEGO1 internal processor fault | 8901 | 3221 | 3 |
| UEGO1 heater supply high voltage | 8902 | 3222 | 3 |
| UEGO1 cal resistor voltage high | 8904 | 3221 | 3 |
| UEGO1 sense cell voltage high | 8910 | 3217 | 3 |
| UEGO1 sense cell slow to warm up | 8914 | 3222 | 10 |
| UEGO1 sense cell impedance high | 8916 | 3222 | 0 |
| UEGO1 internal supply voltage low | 8920 | 3221 | 0 |
| MFG Main Comm Lost | 101A | | |
| MFG Internal Circuitry Fault Detection | 101B | | |
| MFG Delta Pressure zVoltage High | 102A | | |
| MFG Delta Pressure zVoltage High | 102B | | |
| MFG Delta Pressure Voltage High | 102C | | |
| MFG Delta Pressure Voltage Low | 102D | | |
| MFG Delta Pressure Voltage Low | 102E | | |
| MFG RLV Test Failed | 103C | | |
| MFG Unable to Reach Higher TPS | 1020 | 520276 | 31 |
| MFG Supply Voltage High | 1022 | | |
| MFG Supply Voltage Low | 1023 | | |
| MFG Fluid Temperature Voltage High | 1024 | | |
| MFG Fluid Temperature Voltage Low | 1025 | | |
| MFG Upstream Pressure Voltage High | 1026 | | |
| MFG Upstream Pressure Voltage Low | 1027 | | |
| MFG Downstream Pressure Voltage High | 1028 | | |
| MFG Downstream Pressure Voltage Low | 1029 | | |

OBD System Check/MIL (Malfunction Indicator Lamp)

Circuit Description

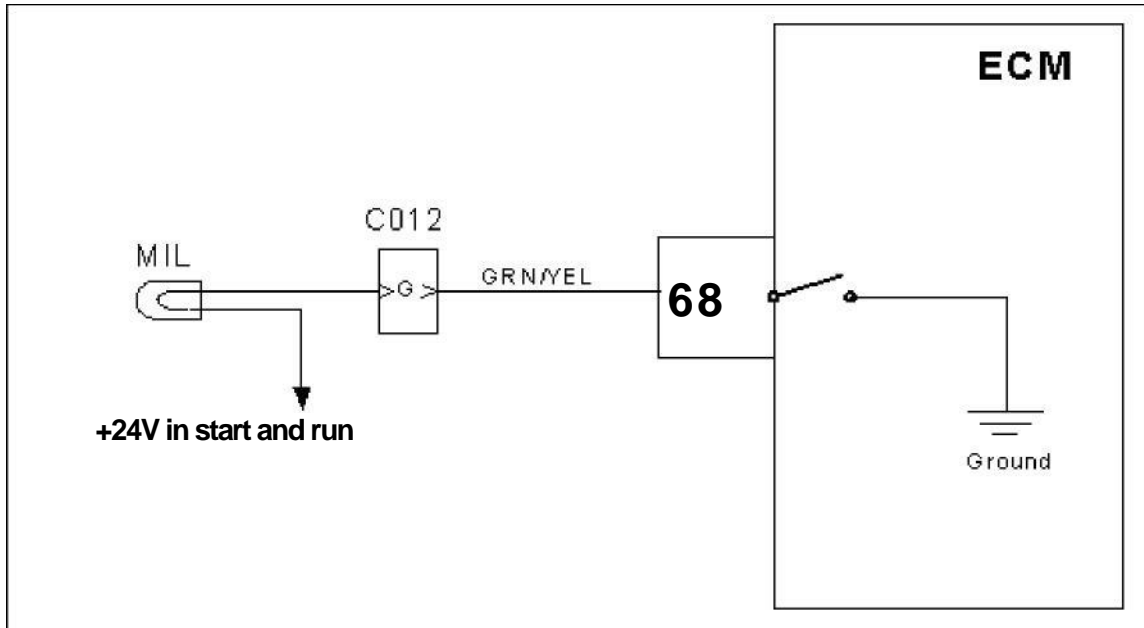

The fuel system is equipped with OBD (On-Board Diagnostics). The MIL serves as notification of an engine or fuel system related problem. The MIL also has the ability to flash DTC codes in what is referred to as the blink code mode. It will display DTCs that have been stored due to a possible system malfunction. The following DTC charts in this manual will instruct the technician to perform the OBD system check. This simply means to verify the operation of the MIL. The codes can be viewed from the Primary (Master) ECM on grounding pin #4 in the diagnostic connector.

DTC 16 - Never Crank Synced at Start

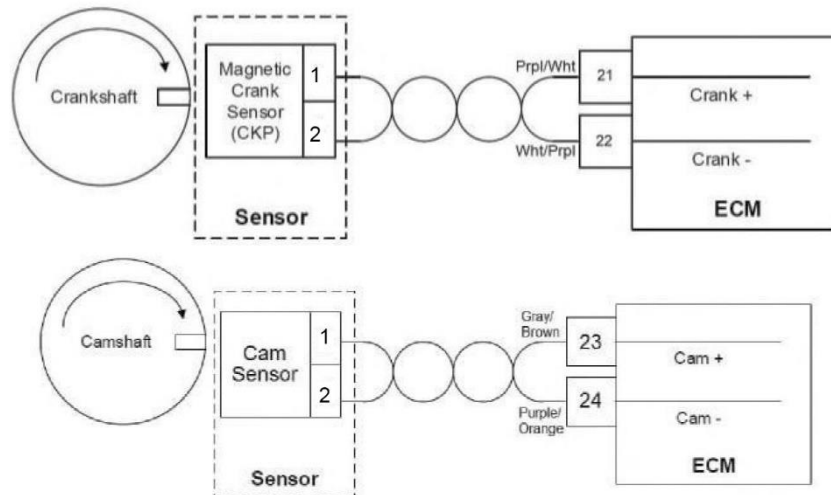

Conditions for Setting the DTC

- Check Condition: Key-On, Engine Cranking or Running
- Fault Condition: Engine speed > 90 RPM, no sync for 4 revs
- MIL: ON during active fault

Fault Description

The crankshaft and camshaft position sensors are magnetic sensors installed in the block adjacent to "coded" trigger wheels that are used to determine crankshaft and camshaft position (with respect to TDC cylinder #1 compression) and the rotational engine speed. The ECM must see a valid crankshaft position and camshaft position signal properly aligned during cranking before it can synchronize the ignition system to initiate starting. If engine speed is greater than 90 RPM and the crank and/or cam cannot synchronize within 4 cranking revs this fault will set. Typically, conditions triggering this fault will result in an engine that will not start or run.

Diagnostic Aids

- Check that the crankshaft and/or camshaft position sensors are securely connected to harness
- Check that the crankshaft and/or camshaft position sensors are securely installed on the engine, and all brackets are tight
- Check crankshaft and/or camshaft position sensor circuits wiring for open circuits

DTC 107 - MAP Low Voltage

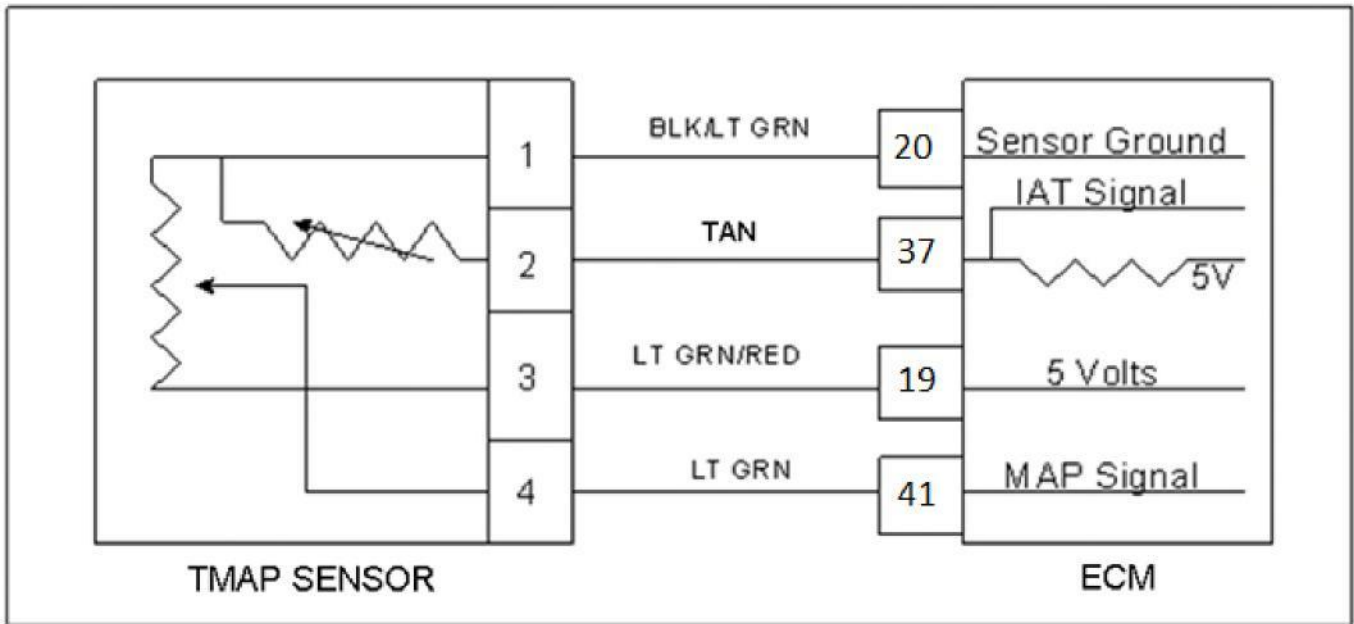

Conditions for Setting the DTC

- Check Condition: Engine cranking or running
- Fault Condition: MAP voltage less than 0.050 with throttle position greater than 2.0% and engine RPM less than 7000.
- MIL: ON
- Engine Shutdown

Circuit Description

The Manifold Absolute Pressure sensor is a pressure transducer connected to the intake manifold. It is used to measure the pressure of air in the manifold prior to induction. The pressure reading is used in conjunction with other inputs to estimate the airflow rate to the engine, which determines the fuel flow rate. This fault will set if the MAP voltage is less than 0.050 with TPS greater than 2% and engine RPM is less than 7000. The fault will cause an engine shutdown.

DTC 107 - MAP Low Voltage

| Step | Action | Value(s) | Yes | No |
|------|--|---|----------------|--------------------------------|
| 1 | Did you perform the On-Board (OBD) System Check? | - | Go to Step (2) | Go to OBD System Check Section |
| 2 | Key ON, Engine Running System Mode = "Running" | Does DST display MAP voltage less than the limit defined in calibration with the engine idling? | Go to Step (3) | Go to Step (4) |
| 3 | Key ON, Engine Off System Mode = "Stopped" | | Go to Step (5) | |
| 4 | Intermittent Problem | | | |
| 5 | If DTC 642 or 643 are present, troubleshoot those first. Using a DMM, measure the voltage potential across 5ref1 and 5Vrtn1 at connector | Does DMM indicate a voltage >4.7 VDC? | Go to Step (6) | |
| 6 | Jumper the MAP circuit to Vref (5 VDC) in connector on harness | Does DST display MAP voltage of 4.7 VDC or greater? | Go to Step (7) | Go to Step (8) |
| 7 | Poor connection at sensor Faulty MAP sensor | | | |
| 8 | Key off Disconnect wire harness header from ECM Carefully remove yellow lock from header at device output terminal CAREFULLY check resistance between MAP input at ECM header and signal at device. NOTE: DO NOT INSERT probe or object into terminals as this will cause the terminal to spread and may no longer contact with ECM pin. Spread pins will void warranty! Probe on the side of terminal. | Is the resistance <5 ohms? | Go to Step (9) | Go to Step (10) |

| Step | Action | Value(s) | Yes | No |
|-------------|---|---|-----------------|-----------------|
| 9 | Reconnect header to ECM Key on, Engine off System mode = "Stopped" Probe MAP signal circuit with a test light connected to battery voltage | Does DST display MAP voltage of 4.0 VDC or greater? | Go to Step (11) | Go to Step (12) |
| 10 | Faulty Harness | | | |
| 11 | Faulty ECM connection Faulty ECM (analog input circuit) | | | |
| 12 | MAP signal shorted to ground Faulty ECM connection Faulty ECM (analog input circuit) | | | |

DTC 108 - MAP High Pressure

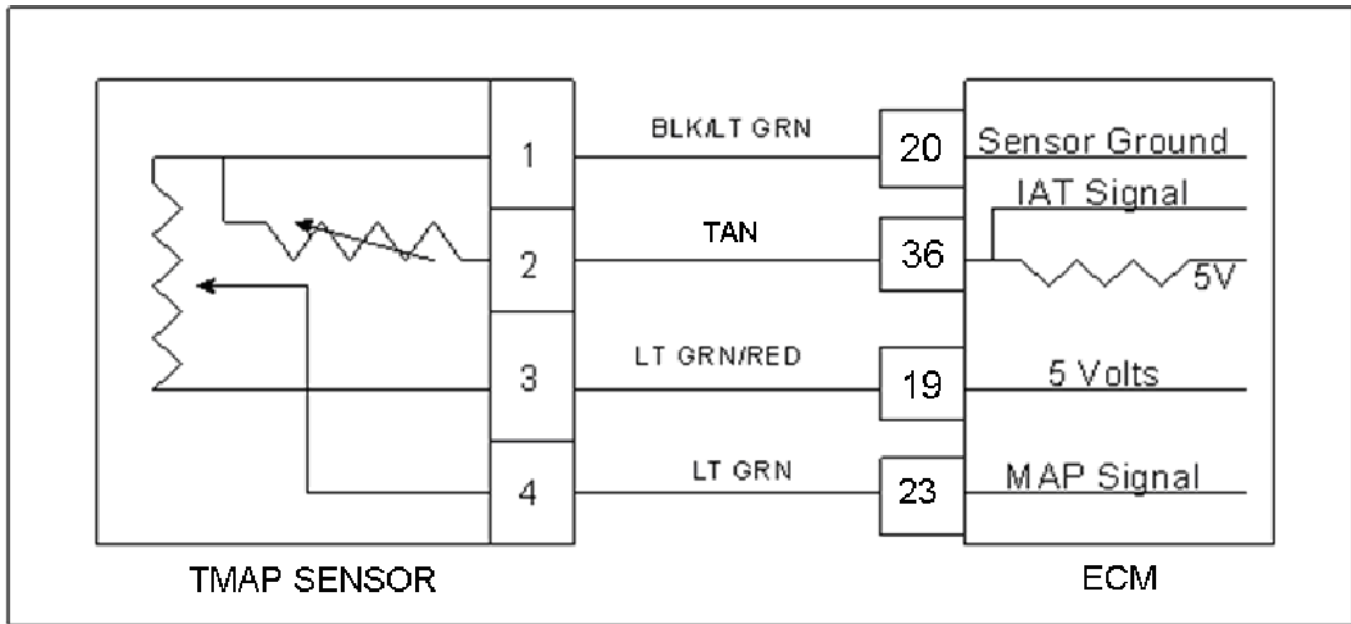

Conditions for Setting the DTC

- Check condition: engine running
- Fault Condition: MAP greater than 35 psi with TPS less than 10% and engine rpm greater than 1400.
- MIL: ON
- Engine Shutdown

Circuit Description

The MAP (Manifold Absolute Pressure) is measured by the MAP sensor. The MAP pressure value is used for fuel, airflow and spark calculations. This fault will set in the event the MAP value is greater than 35 psia when the TPS is less than 10% with engine rpm greater than 1400.

DTC 108 - MAP High Pressure

| Step | Action | Value(s) | Yes | No |
|------|---|--|----------------|--------------------------------|
| 1 | Did you perform the On-Board (OBD) System Check? | - | Go to Step (2) | Go to OBD System Check Section |
| 2 | Key ON, Engine On System Mode = "Running" If engine idle is rough, unstable, missing or incorrect due to suspected engine mechanical problem or vacuum leak etc. Correct the condition before continuing this diagnostic chart. | Does DST display MAP greater than that defined in in the diagnostic calibration? | Go to Step (3) | Go to Step (4) |
| 3 | Key Off Disconnect MAP sensor from engine harness Key ON, Engine Off System Mode = "Stopped" | Does DST display MAP voltage <0.100 VDC? | Go to Step (5) | |
| 4 | Intermittent Problem | | | |
| 5 | Probe sensor ground circuit with test light connected to battery voltage | Does test light come on? | Go to Step (6) | Go to Step (7) |
| 6 | Faulty MAP sensor or pressure connection to intake Faulty MAP sensor Faulty ECM connection | | | |
| 7 | Open sensor ground circuit Faulty ECM | | | |

DTC 111 - IAT Higher Than Expected Stage 1

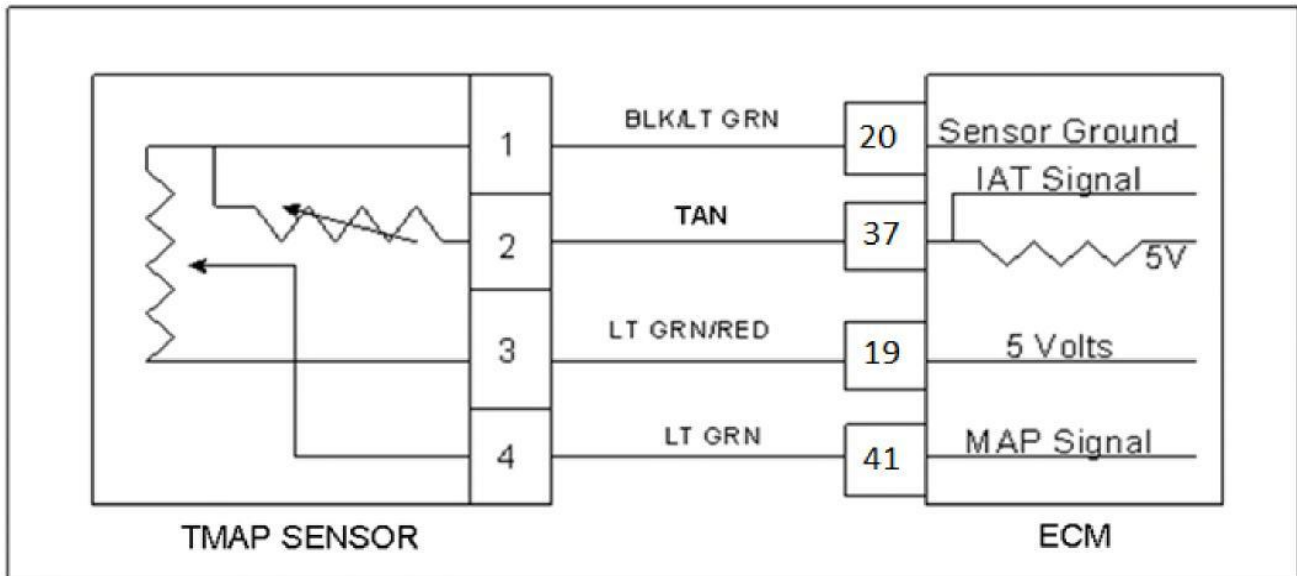

Conditions for Setting the DTC

- Check Condition: Engine Running
- Fault Condition: Intake Air Temperature greater than 140 degrees F
- Condition must be present for a minimum of 30 seconds
- MIL: ON
- Adaptive: Disabled during active fault

Circuit Description

The TMAP is a combined IAT (Intake Air Temperature) and MAP (Manifold Absolute Pressure) sensor. A temperature sensitive resistor is used in the TMAP located in the air intake manifold of the engine. It is used to monitor incoming air temperature, and the output in conjunction with other sensors is used to determine the airflow to the engine. The ECM provides a voltage divider circuit so that when the air is cool, the signal reads higher voltage, and lower when warm. This fault will set if the Intake Air Temperature is greater than 140 degrees F.

Diagnostic Aid

This fault will set when inlet air is much hotter than normal. The most common cause of high inlet air temperature is a problem with the air inlet system or valve lash, which causes a burn back or backfire.

- Ensure that the air inlet is not obstructed, modified, or damaged.
- Ensure the intake air is being sourced from a cool location. Engine heat recirculating into the intake can cause elevated intake air temperatures.
- Inspect the air inlet system for cracks or breaks that may allow unwanted hot air into the air inlet system.
- If none of the above can be found, follow the diagnostic steps for DTC 112- IAT Low Voltage.
- Refer to the 40L Owner's manual or service manual to adjust the valve lash accordingly.

DTC 112 - IAT Low Voltage

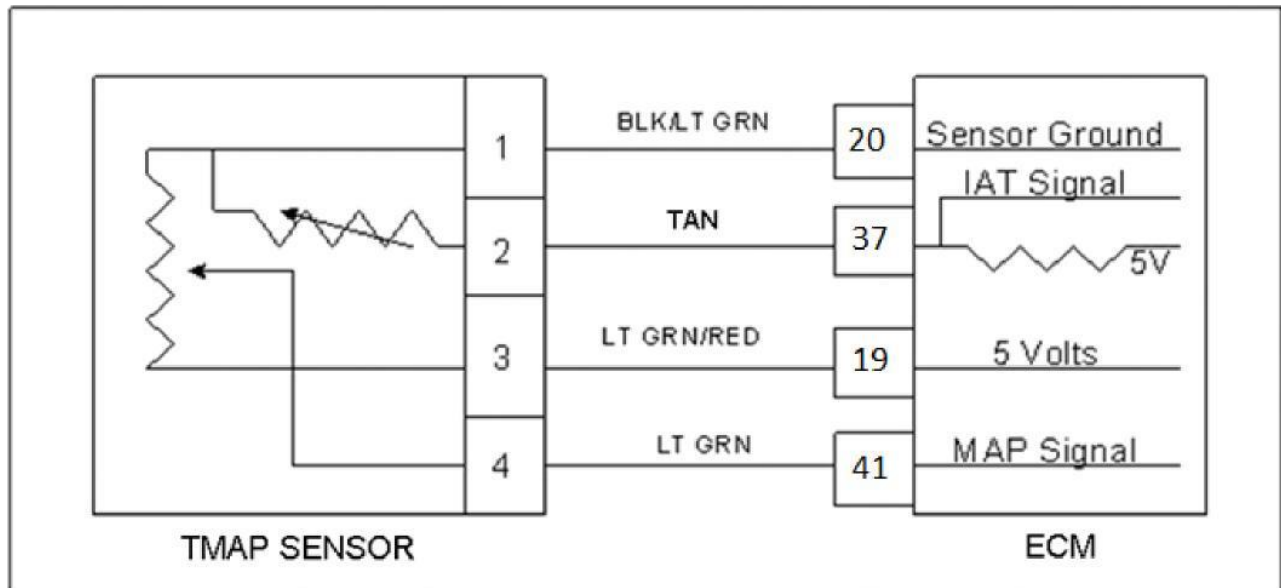

Conditions for Setting the DTC

- Check Condition: Engine Cranking or Running
- Fault Condition: IAT Sensor Voltage less than 0.050
- MIL: ON during active fault
- Engine Shutdown

Circuit Description

The TMAP is a combined IAT (Intake Air Temperature) and MAP (Manifold Absolute Pressure) sensor. A temperature sensitive resistor is used in the TMAP is located in the engine's air intake or intake manifold. It is used to monitor incoming air temperature, and the output in conjunction with other sensors is used to determine the airflow to the engine. The ECM provides a voltage divider circuit so that when the air is cool the signal reads higher voltage, and lower when warm. This fault will set if the signal voltage is less than 0.050 volts for 1 second anytime the engine is cranking or running. The engine will not start if this fault is active, and this fault will cause a shutdown if it becomes active during engine operation.

DTC 112 - IAT Low Voltage

| Step | Action | Value(s) | Yes | No |
|------|--|---|----------------|--------------------------------|
| 1 | Did you perform the On-Board (OBD) System Check? | - | Go to Step (2) | Go to OBD System Check Section |
| 2 | Key ON, Engine On System Mode = "Running" | Does DST display IAT a voltage less the limit defined in calibration? | Go to Step (3) | Go to Step (4) |
| 3 | Intermittent Problem | | | |
| 4 | Key Off Disconnect IAT sensor from harness Key ON, Engine Off System Mode = "Stopped" | Does DST display IAT voltage of 4.9 VDC or greater? | Go to Step (5) | Go to Step (6) |
| 5 | Faulty IAT sensor | | | |
| 6 | Sensor signal circuit shorted to ground, check wire harness for ground short Faulty ECM | | | |

DTC 113 - IAT High Voltage

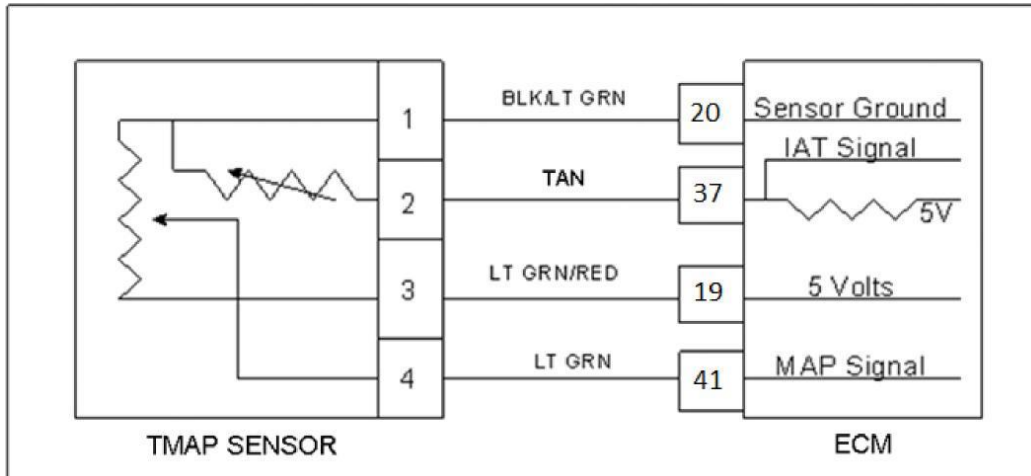

Conditions for Setting the DTC

- Check Condition: Engine Running
- Fault Condition: IAT Sensor Voltage greater than 4.950 volts
- MIL: ON during active fault
- Engine Shutdown

Circuit Description

The TMAP is a combined IAT (Intake Air Temperature) and MAP (Manifold Absolute Pressure) sensor. A temperature sensitive resistor is used in the TMAP is located in the engine's air intake or intake manifold. It is used to monitor incoming air temperature, and the output in conjunction with other sensors is used to determine the airflow to the engine. The ECM provides a voltage divider circuit so that when the air is cool, the signal reads higher voltage, and lower when warm. This fault will set if the signal voltage is greater than 4.950 volts for 1 second or longer. The ECM will use a default value for the IAT sensor in the event of this fault.

DTC 113 - IAT High Voltage

| Step | Action | Value(s) | Yes | No |
|------|--|---|----------------|--------------------------------|
| 1 | Did you perform the On-Board (OBD) System Check? | - | Go to Step (2) | Go to OBD System Check Section |
| 2 | Key ON, Engine Off System Mode = "Stopped" | Does DST display IAT a voltage greater than the limit set in calibration? | Go to Step (3) | Go to Step (4) |
| 3 | Disconnect IAT sensor from harness Jumper across terminal at connector | Does DST display IAT voltage of 0.1 or less? | Go to Step (5) | Go to Step (6) |
| 4 | Intermittent Problem | | | |
| 5 | Faulty connection to sensor Faulty IAT sensor | | | |
| 6 | Jumper IAT sensor signal to ground | Does DST display IAT voltage of 0.1 or less? | Go to Step (7) | Go to Step (8) |
| 7 | Open IAT ground (5Vrtn1) circuit Faulty connection to sensor Faulty IAT sensor | | | |
| 8 | Key Off Disconnect wire harness header from ECM Carefully remove yellow lock from header at device output terminal CAREFULLY check resistance between MAP input at ECM header and signal at device. NOTE: DO NOT INSERT probe or object into terminals as this will cause the terminal to spread and may no longer contact with ECM pin. Spread pins will void warranty! Probe on the side of terminal. | Is the resistance <5 ohms? | Go to Step (9) | Go to Step (10) |
| 9 | Faulty ECM connection Faulty ECM | | | |
| 10 | Faulty Harness | | | |

DTC 116 - ECT Higher Than Expected 1

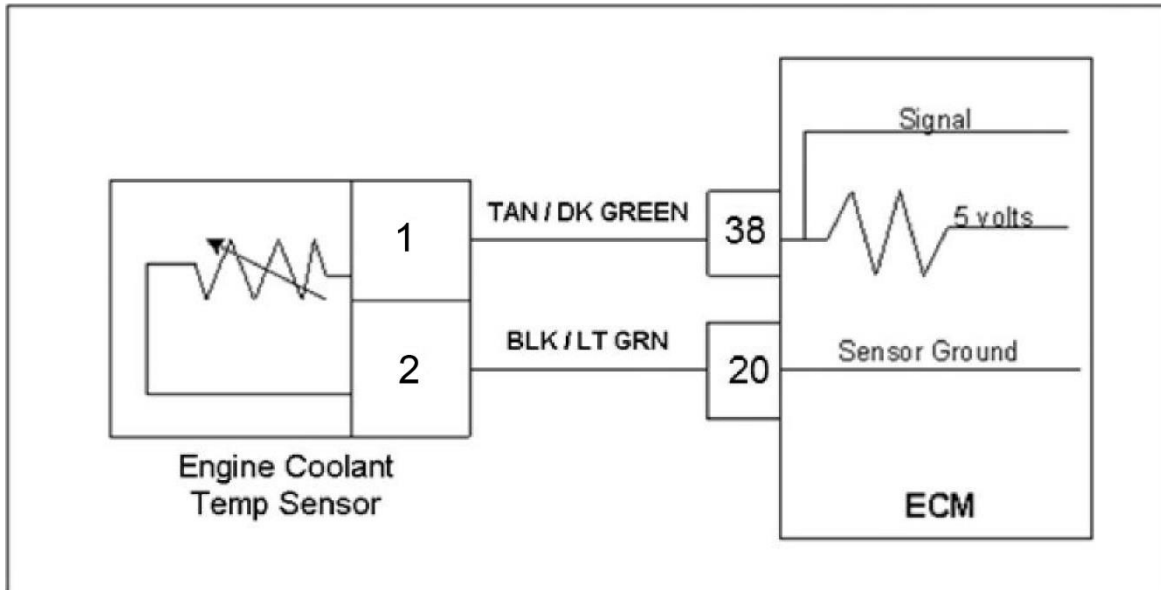

Conditions for Setting the DTC

- Check Condition: Engine Running
- Fault Condition: Engine Coolant Temperature reading greater than 220 degrees F. for 15 seconds
- MIL: On
- Adaptive: Disabled during active fault

Circuit Description

The ECT (Engine Coolant Temperature) sensor is a temperature sensitive resistor located in the engine coolant sensor that is located in the coolant passage. The ECT is used for engine airflow calculation, fuel enrichment, and ignition timing control and to enable certain other temperature dependent operations. This code set is designed to help prevent engine damage from overheating. The ECM provides a voltage divider circuit so when the sensor reading is cool the sensor reads higher voltage, and lower when warm. This fault will set when the coolant exceeds 220 degrees F for more than 15 seconds.

DTC 116 - ECT Higher Than Expected 1

| Step | Action | Value(s) | Yes |
|-------------|--|-----------------|------------------------|
| 1 | Did you perform the On-Board (OBD) System Check? | - | Go to Step (2) |
| 2 | Key ON DST (Diagnostic Scan Tool) connected in system data mode Warm engine to normal operating temperature, then run the engine above 1200 rpm for at least 60 seconds Does the DST display ECT temperature of 220 degrees F or greater? | | Go to Step (3) |
| 3 | Verify with a temperature gauge that the engine coolant is over 220 degrees F. Does the temperature gauge indicate 220 degrees F. or greater? | | Repair cooling system. |
| 4 | Verify ECT Circuit function. Follow diagnostic test procedure for DTC 217 (ECT Higher than expected 2) | | - |

DTC 117 - ECT/CHT Low Voltage

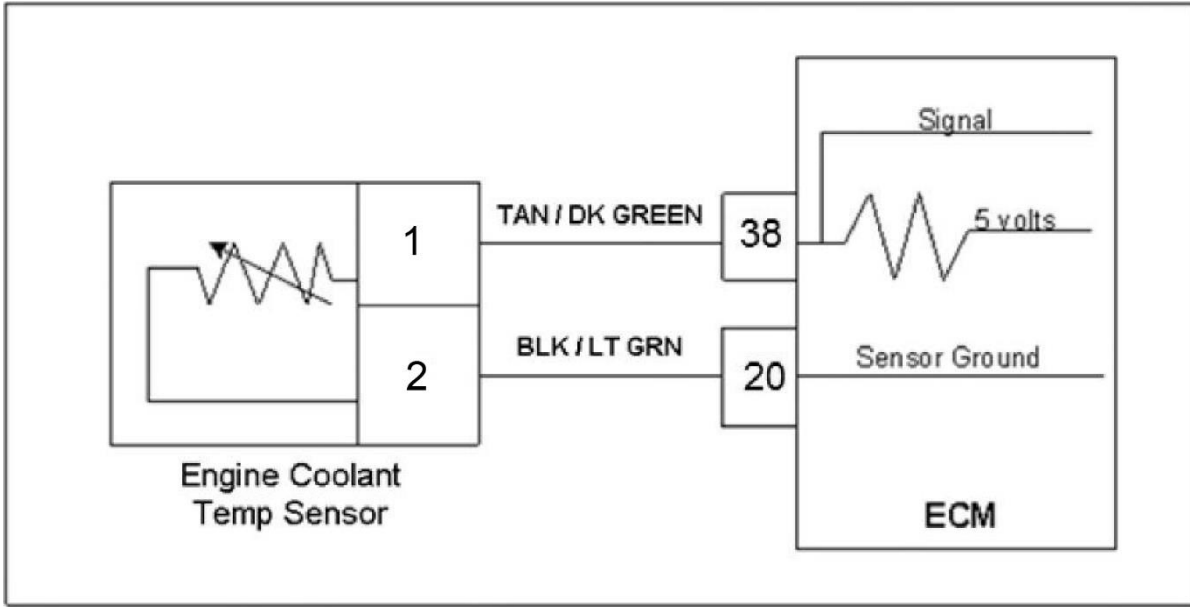

Conditions for Setting the DTC

- Check Condition: Engine Running
- Fault Condition: ECT sensor voltage less than 0.050
- MIL: ON during active fault
- Adaptive: Disabled during active fault

Circuit Description

The ECT (Engine Coolant Temperature) sensor is a temperature sensitive resistor located in the engine coolant passage. It is used for the engine airflow calculation, cold fuel enrichment and to enable other temperature dependent features. The ECM provides a voltage divider circuit so that when the coolant is cool, the signal reads higher voltage, and lower when warm (see table). This fault will set if the signal voltage is less than 0.050 volts for any period longer than 1 second. The ECM will use a default value for the ECT sensor in the event of this fault.

| Temp (deg F) | Ohms +/-10% |
|--------------|-------------|
| 242.4 | 101 |
| 231.9 | 121 |
| 211.6 | 175 |
| 201.4 | 209 |
| 181.9 | 302 |
| 163.1 | 434 |
| 144.9 | 625 |
| 127.4 | 901 |
| 102.4 | 1,556 |
| 78.9 | 2,689 |
| 49.9 | 5,576 |
| 23.5 | 11,562 |
| -5.7 | 28,770 |
| -21.2 | 49,715 |
| -30.8 | 71,589 |
| -40.0 | 99,301 |

DTC 117 - ECT/CHT Low Voltage

| Step | Action | Value(s) | Yes | No |
|------|--|--|----------------|--------------------------------|
| 1 | Did you perform the On-Board (OBD) System Check? | - | Go to Step (2) | Go to OBD System Check Section |
| 2 | Key ON, Engine Running System Mode = "Running" | Does DST display an ECT voltage less the limit defined in calibration? | Go to Step (3) | Go to Step (4) |
| 3 | Key Off Disconnect ECT sensor from harness Key ON, Engine Off System Mode = "Stopped" | Does DST display ECT voltage of 4.9 VDC or greater? | Go to Step (5) | Go to Step (6) |
| 4 | Intermittent Problem | | | |
| 5 | Faulty ECT sensor | | | |
| 6 | Sensor signal circuit shorted to ground, check wire harness for ground short Faulty ECM | | | |

DTC 118 - ECT/CHT High Voltage

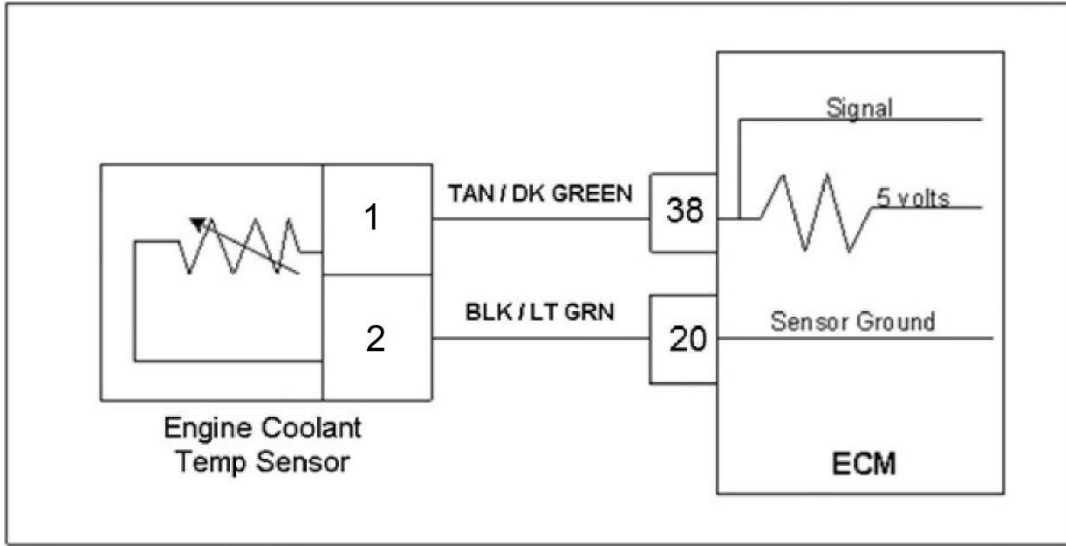

Conditions for Setting the DTC

- Check Condition: Engine Running
- Fault Condition: ECT sensor voltage exceeds 4.950 volts
- MIL: ON during active fault
- Adaptive: Disabled

Circuit Description

The ECT (Engine Coolant Temperature) sensor is a temperature sensitive resistor located in the engine coolant passage. It is used for the engine airflow calculation, cold fuel enrichment and to enable other temperature dependent features. The ECM provides a voltage divider circuit so that when the coolant is cool, the signal reads higher voltage, and lower when warm (see table). This fault will set if the signal voltage is greater than 4.950 volts anytime the engine is running. The ECM will use a default value for the ECT sensor in the event of this fault.

| Temp (deg F) | Ohms +/-10% |
|--------------|-------------|
| 242.4 | 101 |
| 231.9 | 121 |
| 211.6 | 175 |
| 201.4 | 209 |
| 181.9 | 302 |
| 163.1 | 434 |
| 144.9 | 625 |
| 127.4 | 901 |
| 102.4 | 1,556 |
| 78.9 | 2,689 |
| 49.9 | 5,576 |
| 23.5 | 11,562 |
| -5.7 | 28,770 |
| -21.2 | 49,715 |
| -30.8 | 71,589 |
| -40.0 | 99,301 |

DTC 118 - ECT/CHT High Voltage

| Step | Action | Value(s) | Yes | No |
|------|--|---|----------------|--------------------------------|
| 1 | Did you perform the On-Board (OBD) System Check? | - | Go to Step (2) | Go to OBD System Check Section |
| 2 | Key ON, Engine Off System Mode = "Stopped" | Does DST display ECT voltage greater then limit set in calibration? | Go to Step (3) | Go to Step (4) |
| 3 | Disconnect ECT sensor from harness Jumper across terminals at connector | Does DST display ECT voltage of 0.1 or less? | Go to Step (5) | Go to Step (6) |
| 4 | Intermittent Problem | | | |
| 5 | Open ECT ground (5Vrtn1) circuit Faulty connection to sensor Faulty ECT sensor | | | |
| 6 | Key Off Disconnect wire harness header from ECM Carefully remove yellow lock from header at device output terminal CAREFULLY check resistance between MAP input at ECM header and signal at device. NOTE: DO NOT INSERT probe or object into terminals as this will cause the terminal to spread and may no longer contact with ECM pin. Spread pins will void warranty! Probe on the side of terminal. | Is the resistance <5 ohms? | Go to Step (7) | Go to Step (8) |
| 7 | Faulty ECM connection Faulty ECM | | | |
| 8 | Faulty Harness | | | |

DTC 121 - TPS 1 Lower Than TPS 2

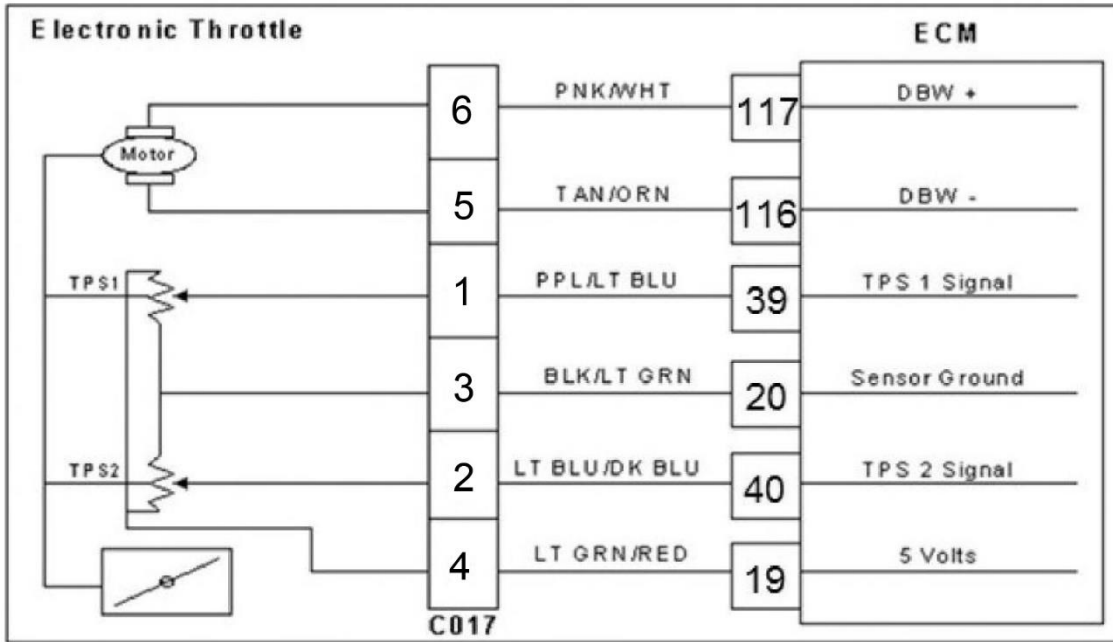

Conditions for Setting the DTC

- Check Condition: Key ON
- Fault Condition: TPS 1 20% lower than TPS 2
- MIL: ON for remainder of key on cycle
- Engine shutdown

Circuit description

Dual throttle position sensors are used within the throttle that use variable resistors to determine signal voltage based on throttle plate position. TPS 1 will read low voltage when closed and TPS 2 will read high voltage when closed. The TPS 1 and TPS 2 percentages are calculated from these voltages. Although the voltages are different, the calculated values for the throttle position percentages should be very close to the same. The TPS values are used by the ECM to determine if the throttle is opening as commanded. This fault will set if TPS 1 is 20% (or more) lower than TPS 2. At this point the throttle is considered to be out of specification, or there is a problem with the TPS signal circuit. The MIL command is ON, and the engine will shut down.

DTC 121 - TPS 1 Lower Than TPS 2

| Step | Action | Value(s) | Yes | No |
|------|--|--|----------------|--------------------------------|
| 1 | Did you perform the On-Board (OBD) System Check? | - | Go to Step (2) | Go to OBD System Check Section |
| 2 | Key ON, Engine Off System Mode = "Stopped" Enable "DBW Test" mode Slowly depress FPP sensor NOTE: To sweep throttle on stationary applications, go to DBW page and type desired throttle opening % in the TPS Command box. | Is TPS1 and TPS2 difference in calibration? | Go to Step (3) | Go to Step (4) |
| 3 | Key Off Disconnect throttle from harness Key ON, Engine Off System Mode = "Stopped" Enable "DBW Test" mode | Is the voltage for both TPS1 and TPS2 <0.100 VDC? | Go to Step (5) | Go to Step (6) |
| 4 | Intermittent Problem | | | |
| 5 | Connect TPS1 signal to the 5V reference at throttle connector while observing TPS1 voltage. Repeat for TPS2 | Does DST display both TPS1 and TPS2 voltage over 4.90 VDC when each is connected to 5Vref? | Go to Step (6) | Go to Step (7) |
| 6 | Key Off Disconnect wire harness header from ECM Carefully remove yellow lock from header at device output terminal CAREFULLY check resistance between MAP input at ECM header and signal at device. NOTE: DO NOT INSERT probe or object into terminals as this will cause the terminal to spread and may no longer contact with ECM pin. Spread pins will void warranty! Probe on the side of terminal. | Are both resistances <5 ohms? | Go to Step (8) | Go to Step (9) |
| 7 | TPS1 or TPS2 signal shorted to ground in harness Faulty ECM connection Faulty ECM | | | |

| | | | | |
|---|----------------|--|--|--|
| 8 | Faulty harness | | | |
|---|----------------|--|--|--|

DTC 122 - TPS 1 Low Voltage

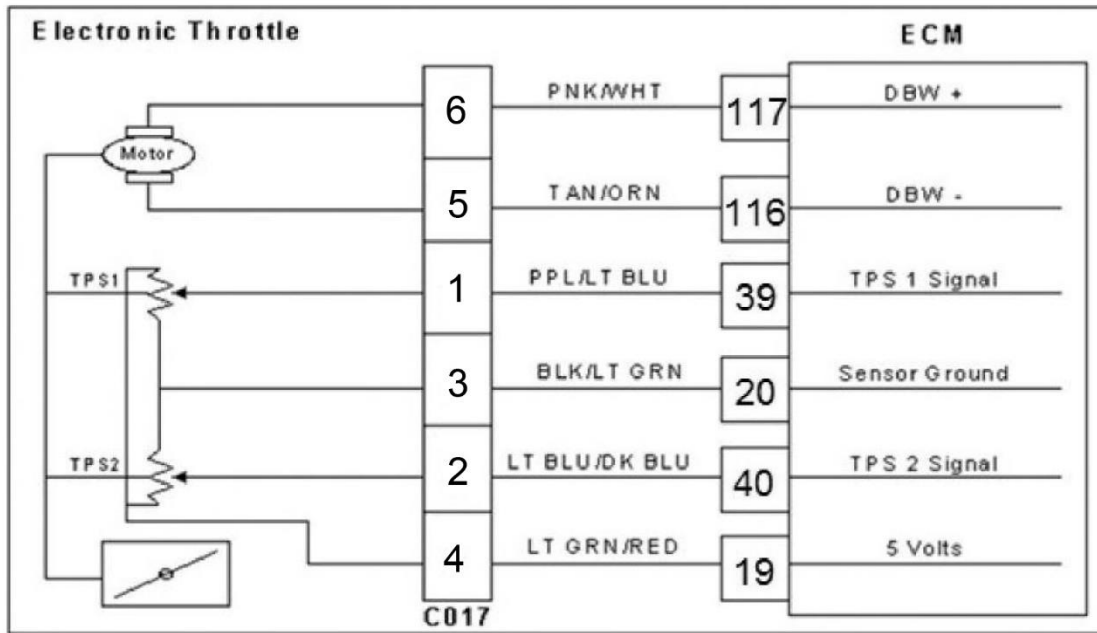

Conditions for Setting the DTC

- Check Condition: Cranking or Running
- Fault Condition: TPS sensor less than 0.200 volts
- MIL: ON during active fault
- Engine shutdown

Circuit Description

Dual throttle position sensors are used within the throttle that use variable resistors to determine signal voltage based on throttle plate position. TPS1 will read lower voltage when closed and TPS2 will read higher voltage when closed. The TPS1 and TPS2 percentages are calculated from these voltages. Although the voltages are different, the calculated values for the throttle position percentages should be very close to the same. The TPS values are used by the ECM to determine if the throttle is opening as commanded. The TPS is not serviceable and in the event of a failure the electronic throttle assembly must be replaced. This fault will set if the TPS 1 voltage is less than 0.200 volts. The MIL command is ON and the engine will shut down.

DTC 122 - TPS 1 Signal Voltage Low

| Step | Action | Value(s) | Yes | No |
|------|---|--|----------------|--------------------------------|
| 1 | Did you perform the On-Board (OBD) System Check? | - | Go to Step (2) | Go to OBD System Check Section |
| 2 | Key ON, Engine Off System Mode = "Stopped" Enable "DBW Test" mode | Is TPS1 voltage low (< 1.00 VDC) at 0% TPS by design? | Go to Step (3) | Go to Step (4) |
| 3 | - | With the <u>throttle</u> closed, does DST display TPS1 voltage < fault condition defined in the calibration? | Go to Step (5) | Go to Step (7) |
| 4 | Slowly depress FP while observing TPS1 voltage NOTE: To sweep throttle on stationary applications, go to DBW page and type desired throttle opening % in the TPS Command box | With the <u>throttle</u> closed, does DST display TPS1 voltage < fault condition defined in the calibration? | Go to Step (5) | Go to Step (6) |
| 5 | Key Off Disconnect throttle from harness. Jumper 5Vref1 to TPS1 signal circuit at throttle connector Key On, Engine Off System Mode=" Stopped" | Does DST display TPS1 voltage > 4.0 VDC? | Go to Step (9) | Go to Step (10) |
| 6 | Slowly depress FPP sensor while observing TPS1 voltage NOTE: To sweep throttle on stationary applications, go to DBW page and type desired throttle opening % in the TPS Command box | Does TPS1 voltage ever fall below the fault condition defined in the calibration? | | Go to Step (7) |
| 7 | Slowly depress FP while observing TPS1 voltage NOTE: To sweep throttle on stationary applications, go to DBW page and type desired throttle opening % in the TPS Command box | Does TPS1 voltage ever fall below the fault condition defined in the calibration? | Go to Step (5) | |

| Step | Action | Value(s) | Yes | No |
|------|--|-------------------------------|-----------------|-----------------|
| 8 | Intermittent problem | | | |
| 9 | Poor Throttle Connection Faulty Throttle | | | |
| 10 | Key Off Disconnect wire harness header from ECM Carefully remove yellow lock from header at device output terminal CAREFULLY check resistance between MAP input at ECM header and signal at device. NOTE: DO NOT INSERT probe or object into terminals as this will cause the terminal to spread and may no longer contact with ECM pin. Spread pins will void warranty! Probe on the side of terminal. | Are both resistances <5 ohms? | Go to Step (11) | Go to Step (12) |
| 11 | TPS1 signal shorted to ground in harness Faulty ECM connection Faulty ECM Faulty Throttle (TPS) | | | |
| 12 | Faulty Harness | | | |

DTC 123 - TPS 1 High Voltage

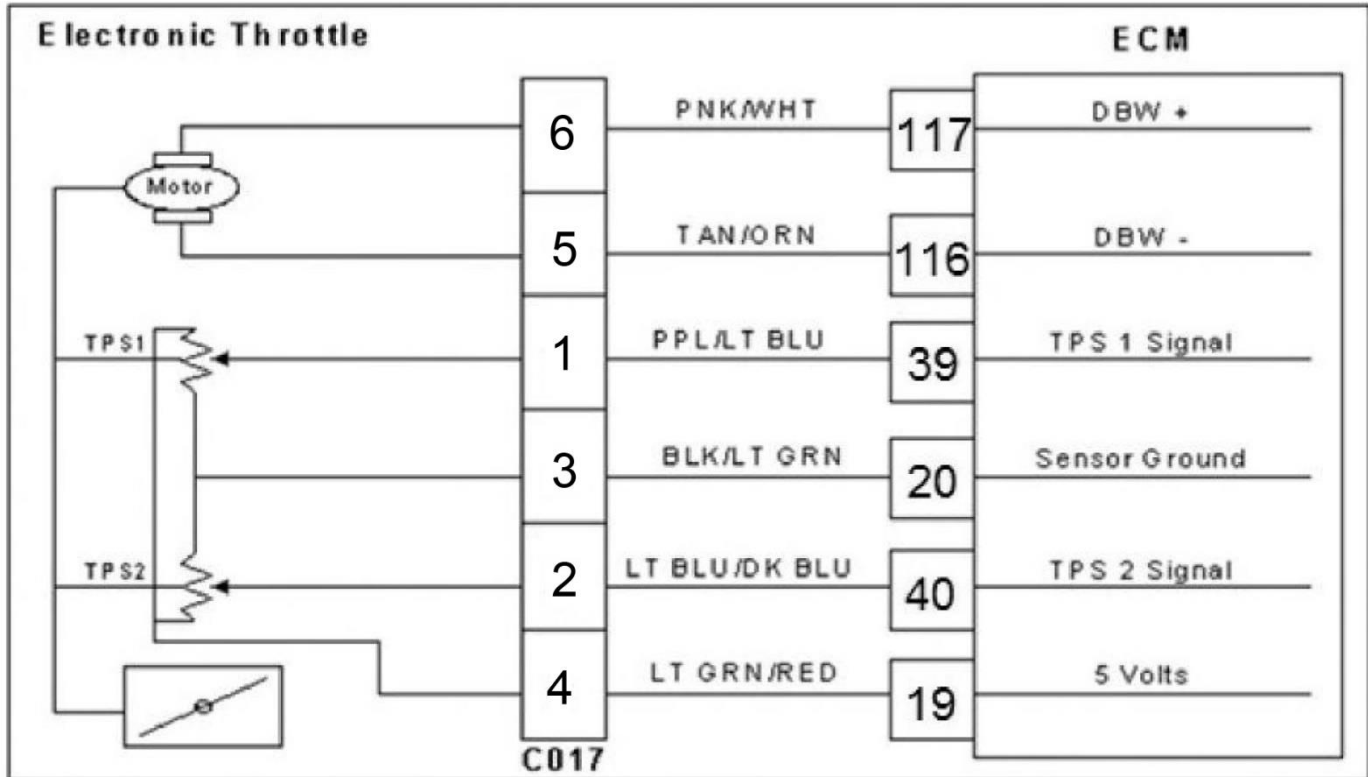

Conditions for Setting the DTC

- Check Condition: Cranking or Running
- Fault Condition: TPS sensor voltage exceeds 4.800 volts
- MIL: ON during active fault
- Engine shutdown

Circuit Description

Dual throttle position sensors are used within the throttle that use variable resistors to determine signal voltage based on throttle plate position. TPS1 will read lower voltage when closed and TPS2 will read higher voltage when closed. The TPS1 and TPS2 percentages are calculated from these voltages. Although the voltages are different, the calculated values for the throttle position percentages should be very close to the same. The TPS values are used by the ECM to determine if the throttle is opening as commanded. The TPS is not serviceable and in the event of a failure the electronic throttle assembly must be replaced. This fault will set if the TPS 1 voltage exceeds 4.800 volts. The MIL command is ON and the engine will shut down.

DTC 123 - TPS 1 High Voltage

| Step | Action | Value(s) | Yes | No |
|------|---|--|----------------|--------------------------------|
| 1 | Did you perform the On-Board (OBD) System Check? | - | Go to Step (2) | Go to OBD System Check Section |
| 2 | Key ON, Engine Off System Mode = "Stopped" Enable "DBW Test" mode | Is TPS1 voltage low (< 1.00 VDC) at 0% TPS by design? | Go to Step (3) | Go to Step (4) |
| 3 | - | With the <u>throttle</u> closed, does DST display TPS1 voltage > fault condition defined in the calibration? | Go to Step (5) | Go to Step (7) |
| 4 | Slowly depress FP while observing TPS1 voltage NOTE: To sweep throttle on stationary applications, go to DBW page and type desired throttle opening % in the TPS Command box | With the <u>throttle</u> closed, does DST display TPS1 voltage > fault condition defined in the calibration? | Go to Step (5) | Go to Step (6) |
| 5 | Key Off Disconnect throttle from harness. Key On, Engine Off System Mode=" Stopped" | Does DST display TPS1 voltage < 0.20 VDC? | Go to Step (9) | Go to Step (10) |
| 6 | Slowly depress FPP sensor while observing TPS1 voltage NOTE: To sweep throttle on stationary applications, go to DBW page and type desired throttle opening % in the TPS Command box | Does TPS1 voltage ever exceed the fault condition defined in the calibration? | | Go to Step (7) |
| 7 | Slowly depress FP while observing TPS1 voltage NOTE: To sweep throttle on stationary applications, go to DBW page and type desired throttle opening % in the TPS Command box | Does TPS1 voltage ever exceed the fault condition defined in the calibration? | Go to Step (5) | |

| Step | Action | Value(s) | Yes | No |
|-------------|--|-----------------------------|-----------------|-----------------|
| 8 | Intermittent problem | | | |
| 9 | TPS1 signal shorted to power Faulty ECM | | | |
| 10 | Probe TPS1 sensor ground circuit at connector with test light connected to battery voltage | Does test light illuminate? | Go to Step (11) | Go to Step (12) |
| 11 | Faulty Throttle connection Faulty Throttle | | | |
| 12 | Open sensor ground Faulty ECM | | | |

DTC 127 - IAT Higher Than Expected 2

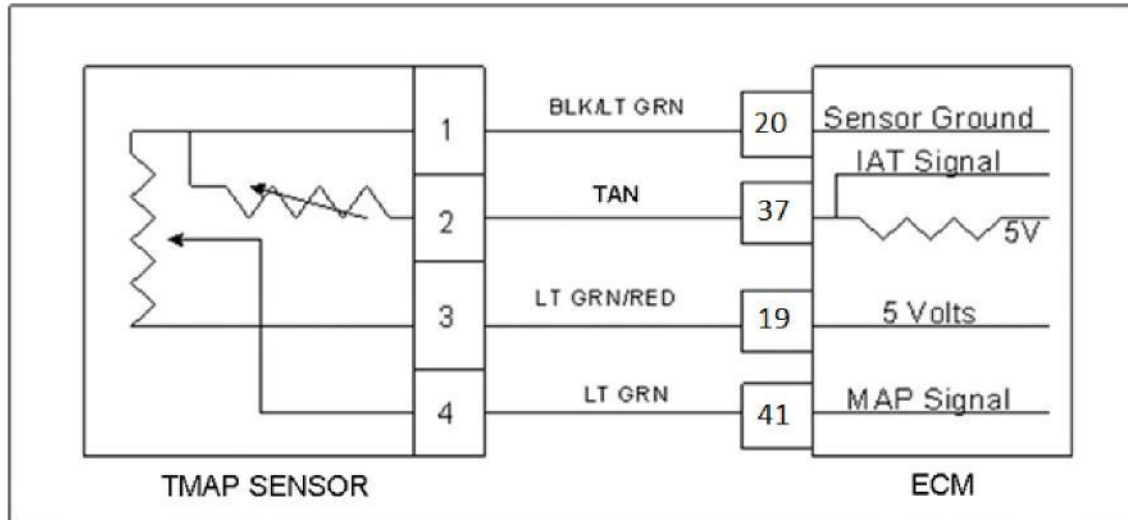

Conditions for Setting the DTC

- Check Condition: Engine Running
- Fault Condition: Intake Air Temperature greater than 155 degrees F. with engine speed greater than 600 rpm
- Fault condition must be active for longer than 5 seconds
- MIL: ON for active fault
- Engine Shut Down

Circuit Description

The TMAP is a combined IAT (Intake Air Temperature) and MAP (Manifold Absolute Pressure) sensor. A temperature sensitive resistor is used in the TMAP located in the intake manifold of the engine. It is used to monitor incoming air temperature, and the output in conjunction with other sensors is used to determine the airflow to the engine. The ECM provides a voltage divider circuit so that when the air is cool, the signal reads a higher voltage, and lower when warm. This fault will set if the intake air temperature is greater than 155 degrees F. with engine speed greater than 600 rpm. The MIL light command is on during this active fault and the engine will shut down.

Diagnostic Aid

- This fault will set when inlet air is much hotter than normal. The most common cause of high inlet air temperature is a problem with the air inlet system. Ensure that the air inlet is not obstructed, modified or damaged, and that hot air from the engine, exhaust, or radiator is not recirculating into the air inlets.
- Another common cause is valve lash. Refer to the 40L Owner's manual or service manual to adjust the valve lash accordingly.
- Inspect the air inlet system for cracks or breaks that may allow heated air into the air inlet system.
- If none of the above can be found, follow the diagnostic steps for DTC 112-IAT Low Voltage.

DTC 129 - BP Low Pressure

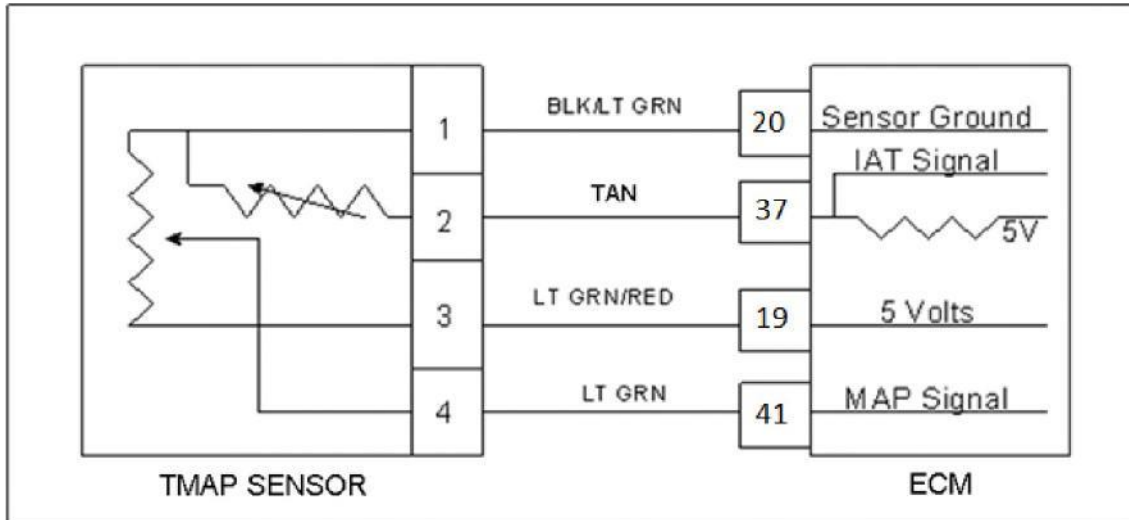

Conditions for Setting the DTC

- Check Condition: Key ON
- Fault Condition: BP less than 8.30 psia
- MIL: ON for active fault
- Adaptive: Disabled

Circuit Description

The BP (Barometric Pressure) is estimated from the TMAP sensor. The barometric pressure value is used for fuel and airflow calculations. This fault sets in the event the BP value is out of the normal range.

DTC 129 - BP Low Pressure

| Step | Action | Value(s) | Yes | No |
|------|--|--|----------------|--------------------------------|
| 1 | Did you perform the On-Board (OBD) System Check? | - | Go to Step (2) | Go to OBD System Check Section |
| 2 | Key ON, Engine Off System Mode = "Stopped" | Does DST display BP less than defined in the diagnostic calibration? | Go to Step (3) | Go to Step (4) |
| 3 | Key Off Disconnect MAP sensor from harness Jumper the MAP circuit to 5Vref1 (5 VDC) in connector on harness Key On, Engine Off System Mode="Stopped" | Does DST display BP > 14.0 psia? | Go to Step (5) | Go to Step (6) |
| 4 | Intermittent problem | | | |
| 5 | Poor connection at sensor Faulty MAP sensor | | | |
| 6 | Key Off Disconnect wire harness header from ECM Carefully remove yellow lock from header at device output terminal CAREFULLY check resistance between MAP input at ECM header and signal at device. NOTE: DO NOT INSERT probe or object into terminals as this will cause the terminal to spread and may no longer contact with ECM pin. Spread pins will void warranty! Probe on the side of terminal. | Is the resistance < 5 ohms? | Go to Step (7) | Go to Step (8) |
| 7 | Reconnect header to ECM Key On, Engine Off System Mode="Stopped" Probe MAP signal circuit with a test light connected to battery voltage | Does DST display BP > 14.0 psia? | Go to Step (9) | Go to Step (10) |
| 8 | Faulty Harness | | | |

| Step | Action | Value(s) | Yes | No |
|------|--|----------|-----|----|
| 9 | 5 Volt reference is open or shorted to ground Faulty ECM connection Faulty ECM | | | |
| 10 | BP/MAP signal circuit shorted to ground Faulty ECM connection Faulty ECM | | | |

DTC 148 - Fuel Run-out Longer Than Expected

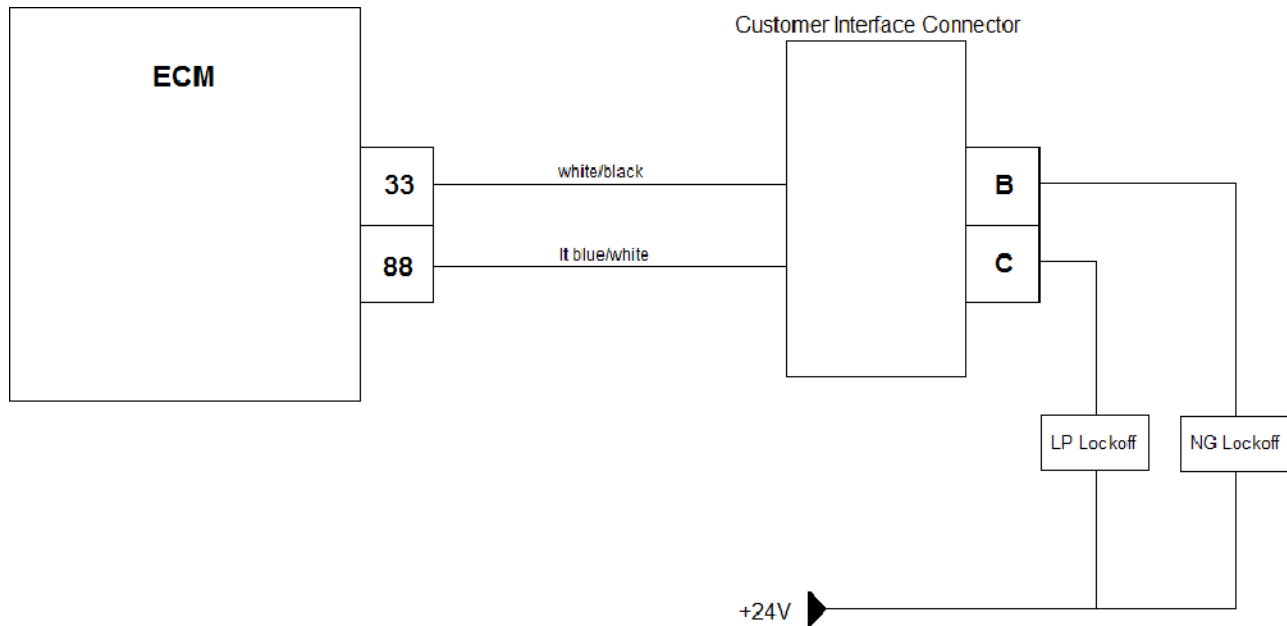

Conditions for Setting the DTC

- Check Condition: Key OFF
- Fault Condition: Engine run down time greater than 10 seconds
- MIL-ON

Circuit Description

The fuel shut off valves are supplied system battery power from the VSW fused source. The ECM then provides a path to ground to turn the valve on. This fault will set in the event the engine continues to run for more than 10 seconds after the key is turned off. This fault indicates a possible problem with the electric fuel shut-off valve, or a wiring issue.

DTC 148 - Fuel Run-out Longer Than Expected

Note:

Ensure to check voltage and ground separately.

| Step | Action | Value(s) | Yes | No |
|------|--|----------------|---|----------------|
| 1 | Did you perform the On-Board (OBD) Sys-Check? | - | Go to Step (2) | |
| 2 | Disconnect the natural gas lockoff solenoid connector. Using a DVOM check for power across terminals A and B while cranking the engine, then turn the key to the OFF position Did the voltage immediately turn OFF with the | System Voltage | Go to Step (3) | Go to Step (5) |
| 3 | Turn off the natural gas manual valve. Start the engine and let it idle until the engine stops. (THIS MAY TAKE SEVERAL MINUTES) Did the engine ever stop? | | Intermittent problem. See intermittent problems in the electrical section of this manual. | Go to Step (4) |
| 4 | Replace the natural gas lockoff solenoid. Is the replacement complete? | | Go to Step (8) | - |
| 5 | Key OFF Disconnect the ECM wire harness header connector Using a DVOM check for continuity between header connector pin 33 and engine ground Do you have continuity? | | Repair the natural gas solenoid control short to ground | Go to Step (6) |
| 6 | Inspect the ECM wire harness and connector for damage corrosion or contamination. Did you find a problem? | | Correct the problem as required. See wire harness repair. | Go to Step (7) |
| 7 | Replace the ECM Is the replacement complete? | | Go to Step (8) | |

| Step | Action | Value(s) | Yes | No |
|------|--|----------|-----------|------------------------|
| 8 | <p>Remove all test equipment except the DST.</p> <p>Connect any disconnected components, fuses, etc.</p> <p>Using the DST clear DTC information from the ECM.</p> <p>Turn the ignition OFF and wait 30 seconds. Start the engine and operate the vehicle to full operating temperature</p> <p>Observe the MIL</p> <p>Observe engine performance and drivability After operating the engine within the test parameters of DTC-359 check for any stored codes.</p> <p>Does the engine operate normally with no stored codes?</p> | | System OK | Go to OBD System Check |

DTC 154 - EGO2 Open/Lazy

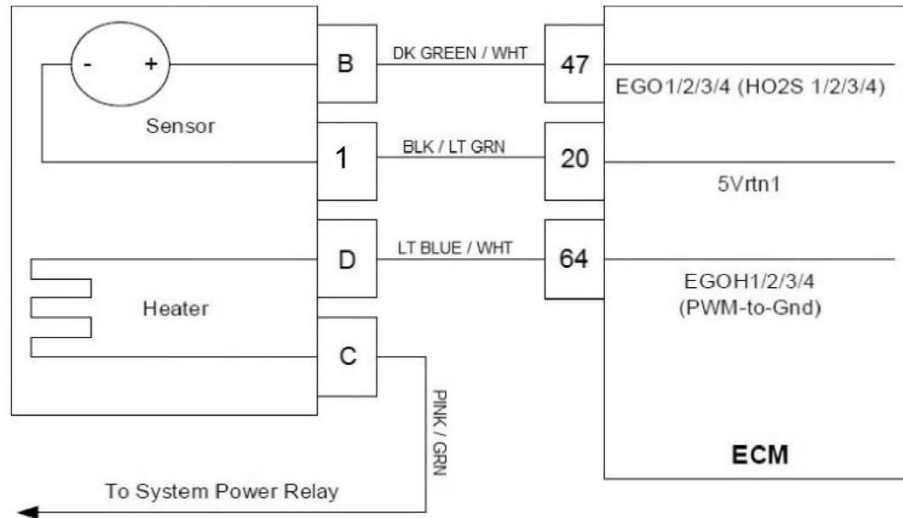

Conditions for Setting the DTC

- Check Condition: Key-On, Engine Running
- Fault Condition: EGO cold persistently for greater than 120 seconds
- MIL: ON during active fault

Fault Description

In a post-catalyst configuration, the HEGO/H2OS sensor is a switching-type sensor around stoichiometry that measures the oxygen content downstream of the catalyst for two main functions: 1) to compare it to the oxygen content upstream of the catalyst to determine how efficiently the catalyst is using oxygen to determine its effectiveness and 2) trim the commanded equivalence ratio target to maximize the catalyst conversion efficiency.

This fault will set if the sensor element is cold, non-responsive, or inactive for 120 seconds. Cold, nonresponsive, or inactive are determined based on two criteria: 1) a measurement of the feedback sense element (zirconia) to determine its temperature or 2) a lack of change in sensor feedback.

DTC 154 - EGO2 Open/Lazy

| Step | Action | Value(s) | Yes | No |
|------|--|--|-----------------|-----------------|
| 1 | Did you perform the On-Board (OBD) Sys-Check? | - | Go to Step (2) | |
| 2 | Key ON, Engine Running Run Mode = "Running" Fuel Control Module="CL Active" or "CL+Adapt" Warm engine to normal operating temperature (ECM must have been powered for > 5 minutes) Ensure that Closed-Loop is active (CL Active or CL+Adapt) | Is HO2S voltage fixed between 0.4 and 0.6 volts? | Go to Step (3) | Go to Step (4) |
| 3 | Using a DMM, check continuity from ECM header to HO2S signal at sensor connector Check continuity from HO2S signal return at sensor connector to Analog Return at the ECM header | Is the resistance < 5 ohms? | Go to Step (6) | Go to Step (5) |
| 4 | Using a DMM, check continuity from ECM header to H)2S heater low side circuit Check continuity from HO2S heater high side to power relay | Is the resistance < 5 ohms? | Go to Step (6) | Go to Step (7) |
| 5 | Repair wiring harness and retest | | | |
| 6 | Using a DST check the HEGO impedance feedback versus target | Is impedance within +/- 50 ohms of target? | Go to Step (8) | Go to Step (9) |
| 7 | Repair wiring harness and retest | | | |
| 8 | Replace HO2S Sensor and retest | Is HO2S properly functioning? | Go to Step (12) | Go to Step (11) |

| Step | Action | Value(s) | Yes | No |
|------|---|---|-----------------|-----------------|
| 9 | <p>With the HO2S sensor connected to the wire harness measure the heater control duty-cycle across heater + and – at sensor</p> <p>Alternately, with the HO2S sensor connected to the wire harness measure the heater control voltage across heater + and – at sensor</p> | Does measured DC or voltage = commanded DC or voltage displayed in DST? | Go to Step (10) | Go to Step (11) |
| 10 | <p>HO2S Heater is not functional or sensor element is cracked</p> <p>Replace HO2S Sensor</p> | | | |
| 11 | Replace ECM | | Go to Step (10) | |
| 12 | HO2S sensor was faulty | | | |

DTC 186 - (3468:1) - FT Gaseous Fuel Extremely Low

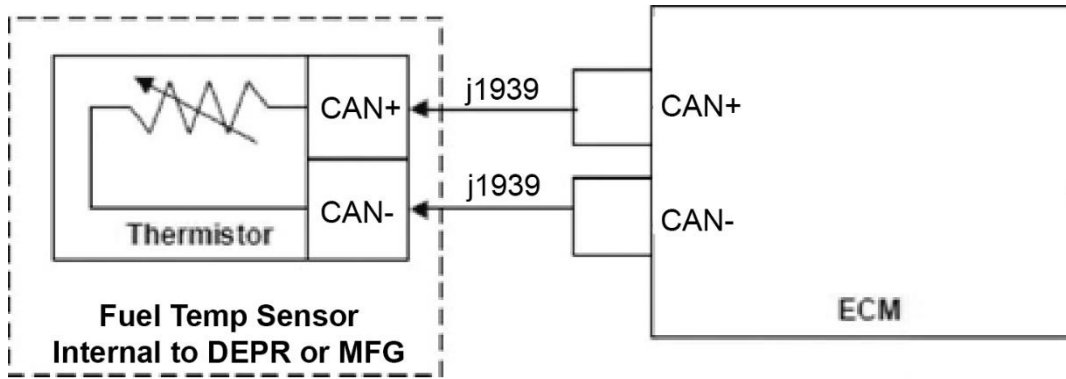

Conditions for Setting the DTC

- Check Condition: Key-On, Engine Running
- Fuel temp < -40 Deg F
- MIL: ON during active fault

Fault Description

The Fuel Temperature sensor is a sealed thermistor (temperature sensitive resistor) integrated into the MFG. Temperature is measured at an upstream-located port and is used as an input in a fuel temperature estimation of the temperature entering the gaseous mixer.

This information is used to calculate a real-time fuel pressure correction in order to reduce fueling errors. The fuel temperature sensor is integrated within the MFG. The temperature data is transmitted to the ECM via the J1939 CAN + and CAN - communication network.

This fault is not user modifiable. It is always enabled and is intended to protect the CFV from extremely low fuel temperatures by load limiting the system when the FT falls below the target temperature given in the fault conditions.

DTC 187 - Fuel Temperature Gaseous Low

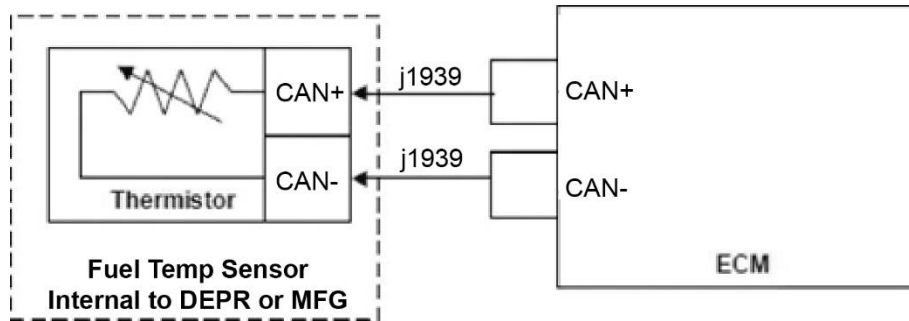

Conditions for setting DTC

- Key on, Engine on
- Fault Conditions: FT voltage less than normal operating voltage or fuel temperature less than normal operating temperature.

Fault Description

The Fuel Temperature sensor is a sealed thermistor (temperature sensitive resistor) integrated into the DEPR. It is used to monitor the gaseous fuel temperature exiting the DEPR to be used as an input in a fuel temperature estimation of the temperature entering the gaseous mixer.

This information is used to calculate a real-time fuel pressure correction in order to reduce fueling errors. The fuel temperature sensor is integrated within the DEPR. The temperature data is transmitted to the ECM via the J1939 CAN+ and CAN- communication network.

The ECM provides a voltage divider circuit so that when the fuel is cool, the signal reads higher voltage, and lower when warm.

DTC 187 - Fuel Temperature Gaseous Low

| Step | Action | Value(s) | Yes | No |
|------|---|---|----------------|--------------------------------|
| 1 | Did you perform the On-Board (OBD) System Check? | - | Go to Step (2) | Go to OBD System Check Section |
| 2 | Key ON, Engine Running System Mode = "Running" | Does DST display FT a voltage less than the limit defined in calibration? | Go to Step (3) | Go to Step (4) |
| 3 | Key OFF Key On, Engine Off System Mode = "Stopped" Wait for fuel pump to stop running Disconnect FT sensor from harness | Does DST display FT voltage of 0.1 or less? | Go to Step (5) | Go to Step (6) |
| 4 | Intermittent Problem Condition is operating condition dependent | | | |
| 5 | Faulty FT sensor | | | |
| 6 | Sensor signal circuit shorted to ground, check wire harness for ground short Faulty ECM | | | |

DTC 188 - (520240:3) - FT Gaseous Fuel High

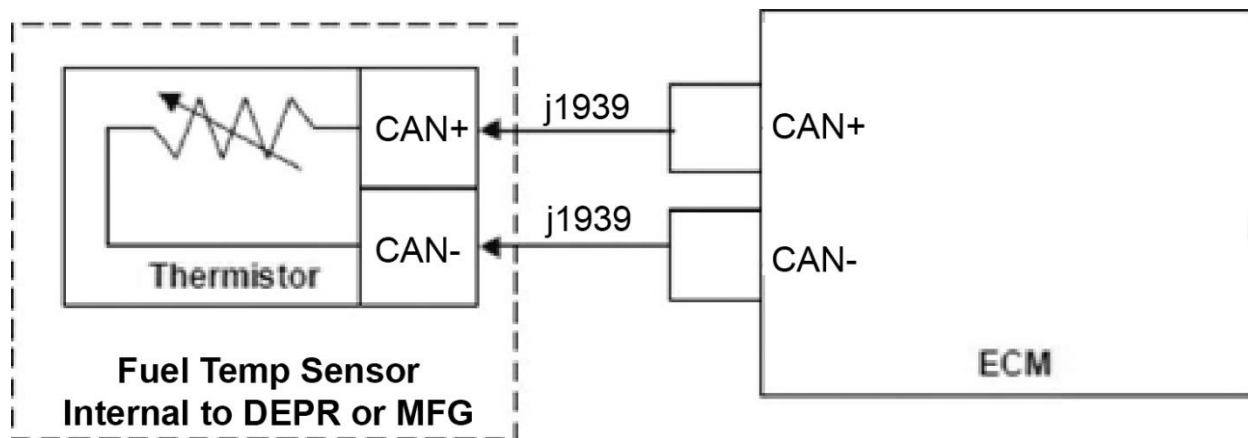

Conditions for Setting the DTC

- Check Condition: Key-On, Engine Running
- Fault Conditions: FT voltage greater than 4.95v or fuel temp is greater than 250F.
- MIL: ON during active fault

Fault Description

The Fuel Temperature sensor is a sealed thermistor (temperature sensitive resistor) integrated into the DEPR. It is used to monitor the gaseous fuel temperature exiting the DEPR to be used as an input in a fuel temperature estimation of the temperature entering the gaseous mixer.

This information is used to calculate a real-time fuel pressure correction in order to reduce fueling errors. The fuel temperature sensor is integrated within the DEPR. The temperature data is transmitted to the ECM via the J1939 CAN+ and CAN- communication network.

This fault code is set when the ECM receives data indicating that the voltage associated with the gaseous fuel temperature sensor is greater than 4.95 volts or when the fuel temperature itself exceeds 250 degrees Fahrenheit. The ECM is programmed to interpret these conditions as potential issues with the gaseous fuel system, and it generates a fault code accordingly.

DTC 188 - (520240:3) - FT Gaseous Fuel High

| Step | Action | Value(s) | Yes | No |
|------|--|----------|---|--------------------------------|
| 1 | Did you perform the On-Board (OBD) System Check? | - | Go to Step (2) | Go to OBD System Check Section |
| 2 | Key ON, Engine OFF System Mode = "Stopped" In 4G Display FAULTS Page, monitor Fuel Temperature. Is the temperature greater than the diagnostic threshold? | >250F | Go to Step (3) | Go to Step (4) |
| 3 | Measure your fuel temp with an infrared gun or temperature probe, Is the fuel temp greater than 250F? | >250F | Determine cause of high fuel temp and resolve | Replace MFG or EPR |
| 4 | Start engine and monitor fuel temp as engine is running. Is the fuel temp greater than 250F? | >250F | Determine cause of high fuel temp and resolve | |

DTC 217 - ECT Higher Than Expected 2

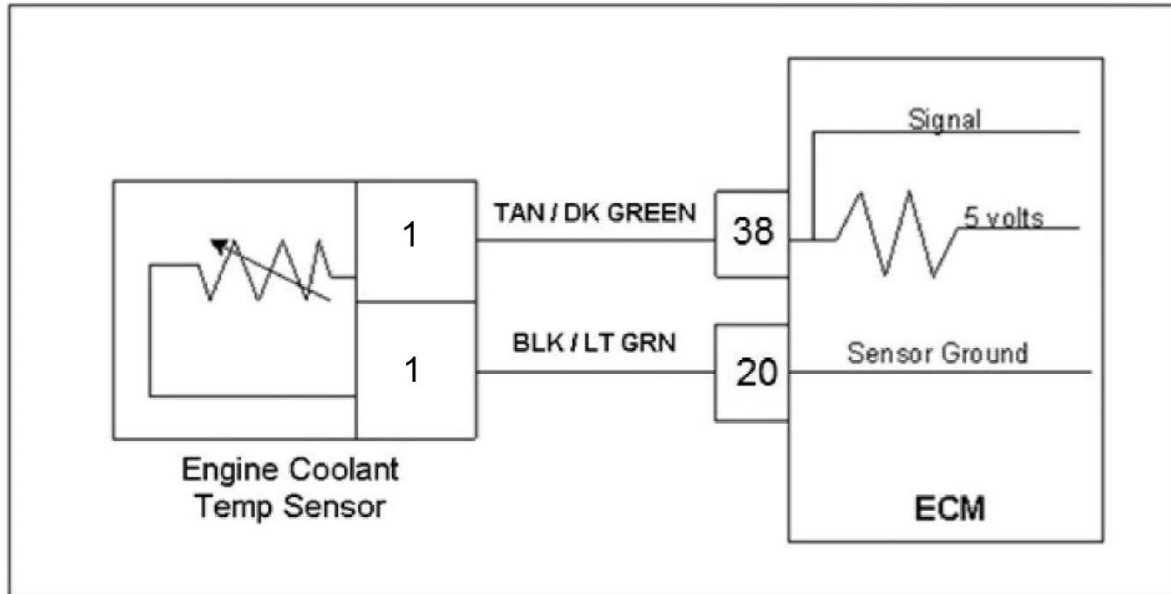

Conditions for Setting the DTC

- Check Condition: Engine Running
- Fault Condition: Engine Coolant Temperature reading or estimate greater than 230 degrees F. for greater than 10 seconds
- MIL: On
- Engine shutdown will occur

Circuit Description

The ECT (Engine Coolant Temperature) sensor is a temperature sensitive resistor located in the engine coolant sensor that is located in the coolant passage. The ECT is used for engine airflow calculation, fuel enrichment, and ignition timing control and to enable certain other temperature dependent operations. This code set is designed to help prevent engine damage from overheating. The ECM provides a voltage divider circuit so when the sensor reading is cool the sensor reads higher voltage, and lower when warm. This fault will set when the coolant exceeds 230 degrees F. for more than 10 seconds. Engine shutdown will occur if this code occurs.

This is not an electronic fault; the engine is running too hot. The cooling system should be thoroughly inspected to find the root cause of the overheating.

- Is the cooling system full?
- Is the coolant in the cooling system the proper type, and is it the proper 50/50 mix of coolant and water?
- Are the fan belts intact and tight?
- Is the radiator clean? Debris on the radiator core and impede airflow through the radiator and cause the engine to overheat. Bear in mind that most engines are equipped with pusher fans, so the side of the radiator core closest to the engine will be the one to get coated with debris. Fan guards may need to be removed in order to inspect and properly clean the radiator core.
- Is hot air recirculating around the radiator, or is hot exhaust being drawn into the airflow through the radiator?

DTC 221 - TPS 1 Higher Than TPS 2

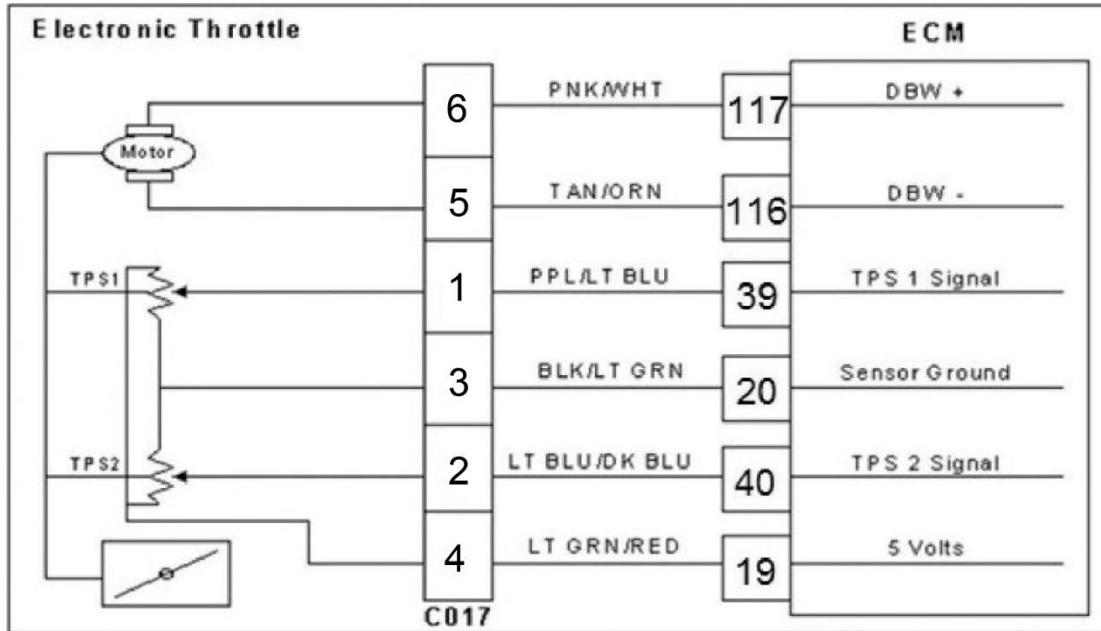

Conditions for Setting the DTC

- Check Condition: Key ON
- Fault Condition: TPS 1 20% higher than TPS2
- MIL: ON for remainder of key on cycle
- Engine shutdown

Circuit Description

Dual throttle position sensors are used within the throttle that use variable resistors to determine signal voltage based on throttle plate position. TPS 1 will read lower voltage when closed and TPS 2 will read higher voltage when closed. The TPS 1 and TPS 2 percentages are calculated from these voltages. Although the voltages are different, the calculated values for the throttle position percentages should be very close to the same. The TPS values are used by the ECM to determine if the throttle is opening as commanded. The TPS is not serviceable and in the event of a failure the electronic throttle assembly must be replaced. This fault will set if TPS 1 is 20% (or more) higher than TPS 2. At this point the throttle is considered to be out of specification, or there is a problem with the TPS signal circuit. The MIL command is ON and the engine will shut down.

DTC 221 - TPS 1 Higher Than TPS 2

| Step | Action | Value(s) | Yes | No |
|------|---|--|----------------|--------------------------------|
| 1 | Did you perform the On-Board (OBD) System Check? | - | Go to Step (2) | Go to OBD System Check Section |
| 2 | Key ON, Engine OFF System Mode = "Stopped" Enable "DBW Test" mode Slowly Depress FPP sensor NOTE: To sweep throttle on stationary applications, go to DBW page and type desired throttle opening % in the TPS Command box | Is TPS1 and TPS2 difference more than the fault condition defined in the calibration? | Go to Step (3) | Go to Step (4) |
| 3 | Key Off Disconnect throttle from harness Key On, Engine Off System Mode – "Stopped" Enable "DBW Test" mode | Is the voltage for both TPS1 and TPS2 < 0.100 VDC? | Go to Step (5) | Go to Step (6) |
| 4 | Intermittent problem. | | | |
| 5 | Connect TPS1 signal to the 5V reference at throttle connector while observing TPS1 voltage Repeat for TPS2 | Does DST display both TPS1 and TPS2 voltage over 4.90 VDC when each is connected to 5Vref? | Go to Step (7) | Go to Step (8) |
| 6 | TPS (the one over 0.1 volts) is shorted to voltage in the harness Faulty ECM | | | |
| 7 | Faulty connection at throttle Faulty throttle | | | |

| Step | Action | Value(s) | Yes | No |
|------|---|-------------------------------|----------------|-----------------|
| 8 | Key Off Disconnect wire harness header from ECM Carefully remove yellow lock from header at device output terminal CAREFULLY check resistance between TPS1 and TPS2 input ECM header and signal at device. NOTE: DO NOT INSERT probe or object into terminals as this will cause the terminal to spread and may no longer make contact with ECM pins. Spread pins will void warranty! Probe on the side of terminal. | Are both resistances <5 ohms? | Go to Step (9) | Go to Step (10) |
| 9 | TPS1 and TPS2 signal shorted to ground in harness Faulty ECM connection Faulty ECM | | | |
| 10 | Faulty Harness | | | |

DTC 222 - TPS 2 Signal Voltage Low

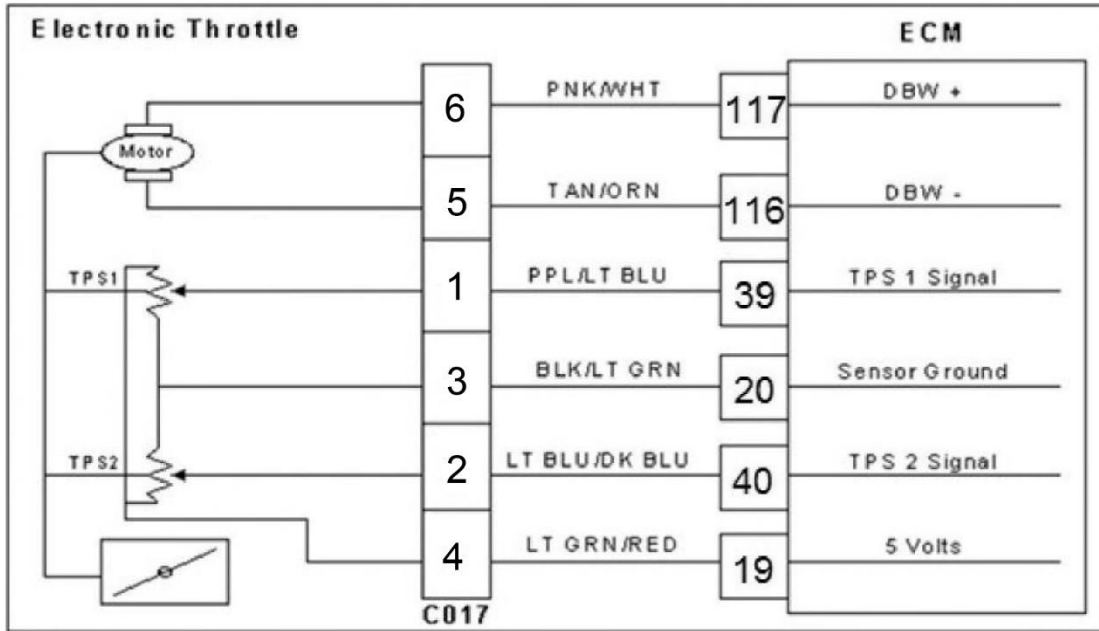

Conditions for Setting the DTC

- Check Condition: Cranking or Running
- Fault Condition: TPS 2 sensor voltage less than 0.200 volts
- MIL: ON during active fault

Circuit Description

Dual throttle position sensors are used within the throttle that use variable resistors to determine signal voltage based on throttle plate position. TPS1 will read lower voltage when closed and TPS2 will read higher voltage when closed. The TPS1 and TPS2 percentages are calculated from these voltages. Although the voltages are different, the calculated values for the throttle position percentages should be very close to the same. The TPS values are used by the ECM to determine if the throttle is opening as commanded. The TPS is not serviceable and in the event of a failure the electronic throttle assembly must be replaced. This fault will set if the TPS 2 voltage is less than 0.200 volts. The MIL command is ON.

DTC 222 - TPS 2 Signal Voltage Low

| Step | Action | Value(s) | Yes | No |
|------|---|--|----------------|--------------------------------|
| 1 | Did you perform the On-Board (OBD) System Check? | - | Go to Step (2) | Go to OBD System Check Section |
| 2 | Key ON, Engine OFF System Mode = "Stopped" Enable "DBW Test" mode | Is TPS2 voltage low (< 1.00 VDC) at 0% TPS by design? | Go to Step (3) | Go to Step (4) |
| 3 | - | Does DST display TPS2 voltage <0.2 VDC with the throttle closed? | Go to Step (5) | Go to Step (6) |
| 4 | Slowly Depress FP while observing TPS2 voltage NOTE: To sweep throttle on stationary applications, go to DBW page and type desired throttle opening % in the TPS Command box | Does DST display TPS2 voltage <0.2 VDC with the throttle open? | Go to Step (5) | Go to Step (7) |
| 5 | Key OFF Disconnect throttle from harness | | Go to Step (8) | |
| 6 | Slowly release FPP sensor while observing TPS2 voltage. NOTE: To sweep throttle on stationary applications, go to DBW page and type desired throttle opening % in the TPS Command box. | Does TPS2 voltage ever fall below 0.2 volts? | Go to Step (5) | Go to Step (7) |
| 7 | Intermittent Problem | | | |
| 8 | Jumper 5Vref1 to TPS2 signal circuit at throttle connector Key On, Engine Off System Mode="Stopped" | Does DST display TPS2 voltage >4.0 VDC? | Go to Step (9) | Go to Step (10) |
| 9 | Poor Throttle Connection Faulty Throttle | | | |

| Step | Action | Value(s) | Yes | No |
|------|---|--------------------------------|-----------------|-----------------|
| 10 | Key Off Disconnect wire harness header from ECM Carefully remove yellow lock from header at device output terminal CAREFULLY check resistance between TPS2 input at ECM header and signal at device. NOTE: DO NOT INSERT probe or object into terminals as this will cause the terminal to spread and may no longer make contact with ECM pins. Spread pins will void warranty! Probe on the side of terminal. | Are both resistances < 5 ohms? | Go to Step (11) | Go to Step (12) |
| 11 | TPS2 signal shorted to ground in harness Faulty ECM connection Faulty ECM Faulty Throttle (TPS) | | | |
| 12 | Faulty Harness | | | |

DTC 223 - TPS 2 Signal Voltage High

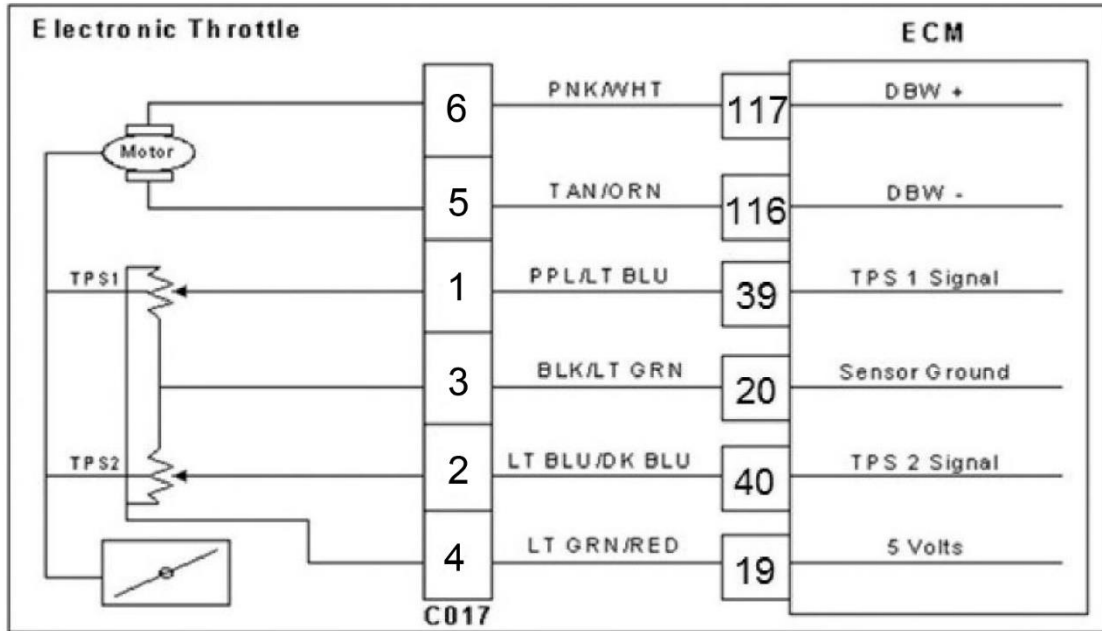

Conditions for Setting the DTC

- Check Condition: Cranking or Running
- Fault Condition: TPS 2 sensor exceeds 4.800 volts
- MIL: ON during active fault

Circuit Description

Dual throttle position sensors are used within the throttle that uses variable resistors to determine signal voltage based on throttle plate position. TPS1 will read lower voltage when closed and TPS2 will read higher voltage when closed. The TPS1 and TPS2 percentages are calculated from these voltages. Although the voltages are different, the calculated values for the throttle position percentages should be very close to the same. The TPS values are used by the ECM to determine if the throttle is opening as commanded. The TPS is not serviceable and in the event of a failure the electronic throttle assembly must be replaced. This fault will set if the TPS 2 voltage is greater than 4.800 volts. The MIL command is ON.

DTC 223 - TPS 2 Signal Voltage High

| Step | Action | Value(s) | Yes | No |
|------|---|---|----------------|--------------------------------|
| 1 | Did you perform the On-Board (OBD) System Check? | - | Go to Step (2) | Go to OBD System Check Section |
| 2 | Key ON, Engine OFF System Mode = "Stopped" Enable "DBW Test" mode | Is TPS2 voltage low (< 1.00 VDC) at 0% TPS by design? | Go to Step (3) | Go to Step (4) |
| 3 | - | Does DST display TPS2 voltage >4.80 VDC with the throttle closed? | Go to Step (5) | Go to Step (13) |
| 4 | Slowly Depress FP while observing TPS2 voltage NOTE: To sweep throttle on stationary applications, go to DBW page and type desired throttle opening % in the TPS Command box | Does DST display TPS2 voltage >4.80 VDC with the throttle open? | Go to Step (5) | Go to Step (7) |
| 5 | Key OFF Disconnect throttle from harness Key On, Engine Off System Mode = "Stopped" | Does DST display TPS2 voltage <0.20 VDC? | Go to Step (9) | Go to Step (10) |
| 6 | Slowly release FPP sensor while observing TPS2 voltage. NOTE: To sweep throttle on stationary applications, go to DBW page and type desired throttle opening % in the TPS Command box. | Does TPS2 voltage ever fall below 0.2 volts? | | |
| 7 | Slowly release FPP sensor while observing TPS2 voltage. NOTE: To sweep throttle on stationary applications, go to DBW page and type desired throttle opening % in the TPS Command box. | Does DST voltage ever exceed 4.80 VDC | Go to Step (5) | Go to Step (8) |
| 8 | Intermittent Problem | | | |

| Step | Action | Value(s) | Yes | No |
|------|---|---------------------------------------|-----------------|-----------------|
| 9 | TPS2 signal shorted to power Faulty ECM | | | |
| 10 | Probe TPS2 sensor ground circuit at connector with test light connected to battery voltage. | Does test light illuminate? | Go to Step (11) | Go to Step (12) |
| 11 | Faulty throttle connection Faulty Throttle | | | |
| 12 | Open sensor ground Faulty ECM | | | |
| 13 | Slowly Depress FP while observing TPS2 voltage NOTE: To sweep throttle on stationary applications, go to DBW page and type desired throttle opening % in the TPS Command box | Does DST voltage ever exceed 4.80 VDC | Go to Step (8) | Go to Step (5) |

DTC 236 - TIP/TOP Active

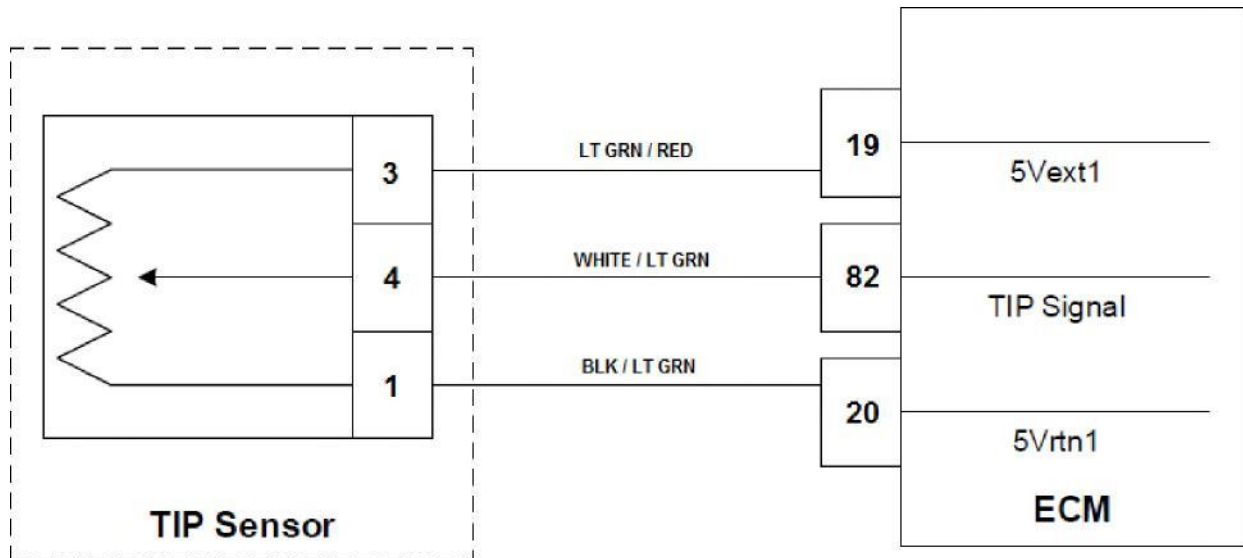

Conditions for Setting the DTC

- Check Condition: Key On, Engine Running
- Fault Condition: TIP < 16 psia and MAP > 18 psia
- MIL on
- Adaptive disabled

Fault Description

The engine uses a throttle inlet pressure (TIP) sensor upstream of the throttle valve to monitor incoming throttle pressure. The TIP should always be higher than the MAP. If MAP is ever at 18 psia or higher and TIP is reading at less than 16 psia, a TIP/TOP active fault is logged.

Diagnosing the Fault

Check to make sure the wiring for the TIP and MAP sensors is not reversed. The two sensors are identical and they are close enough to each other that it is possible to swap the connectors. The TIP sensor, located on the charge air piping, should have three wires at the connector while the MAP sensor, located on the throttle body adapter on the intake manifold, should have four wires at the connector. If the wiring for the sensors is correct, check to ensure the sensor is properly installed in the CAC piping. It should be held in place with a retaining bolt. Ensure it is fully installed into the pipe and the bolt is tight.

If the installation is correct, remove the sensor and inspect for damage. Replace the sensor with a known good part and test again.

DTC 237 - TIP/TOP Low Voltage

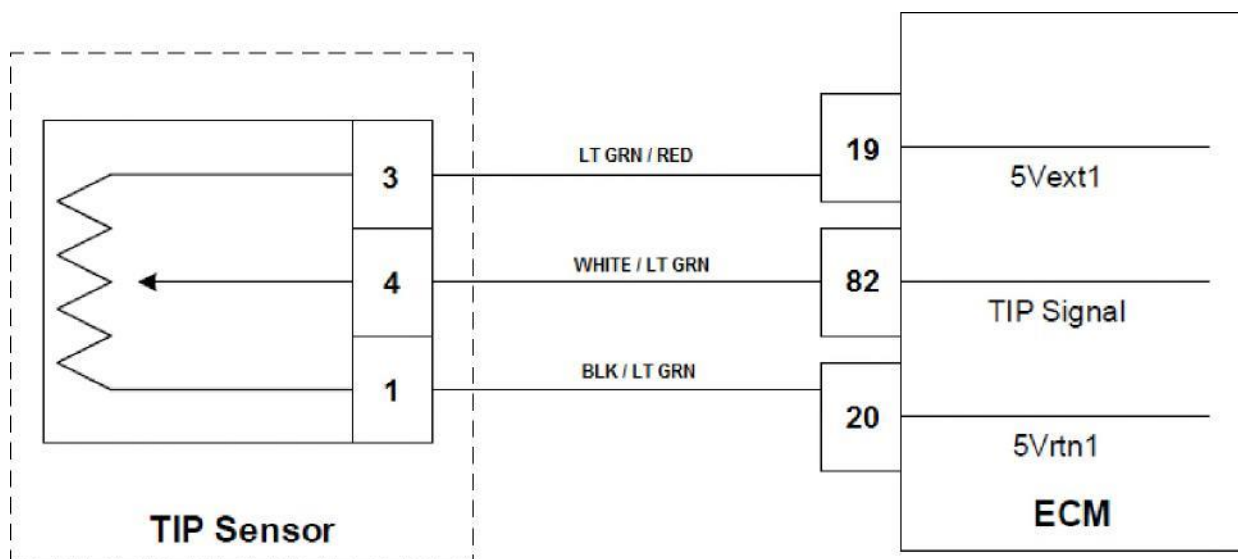

Conditions for Setting the DTC

- Throttle Inlet Pressure
- Check Condition: Key On, Engine Off
- Fault Condition: TIP voltage less than 0.2V
- MIL on
- Adaptive disabled

Fault Description

The engine uses a throttle inlet pressure (TIP) sensor upstream of the throttle valve to monitor incoming throttle pressure. This fault will set when the TIP sensor voltage feedback is sensed as lower than the sensor should normally produce as set in the diagnostic calibration.

Diagnosing the Fault

In many cases, this condition is caused by the TIP sensor being disconnected from the engine harness, an open-circuit or short-to-ground of the TIP sensor circuit in the wire harness, a loss of sensor reference voltage, or a failure of the sensor.

DTC 237 - TIP/TOP Low Voltage

| Step | Action | Value(s) | Yes | No |
|------|---|---|----------------|--------------------------------|
| 1 | Did you perform the On-Board (OBD) System Check? | - | Go to Step (2) | Go to OBD System Check Section |
| 2 | Key ON, Engine Running System Mode = "Running" | Does DST display TIP voltage less than the limit defined in calibration with the engine running?? | Go to Step (3) | Go to Step (4) |
| 3 | Key On, Engine Off System Mode ="Stopped" | | Go to Step (5) | |
| 4 | Intermittent Problem | | | |
| 5 | If DTC 642 or 643 are present, troubleshoot those first. Using a DMM, measure the voltage potential across 5Vref1 and 5Vrtn1 at connector. | Does DMM indicate a voltage >4.7 VDC? | Go to Step (6) | Go to Step (7) |
| 6 | Jumper the TIP circuit to Vref (5 VDC) in connector on harness. | Does DST display TIP voltage of 4.7 VDC or greater? | Go to Step (8) | Go to Step (9) |
| 7 | Faulty harness (check 5Vref1 and 5Vrtn1 connections) Faulty ECM (5Vref power supply). | | | |
| 8 | Poor connection at sensor Faulty TIP sensor | | | |

| Step | Action | Value(s) | Yes | No |
|------|---|---|-----------------|-----------------|
| 9 | <p>Key Off</p> <p>Disconnect wire harness header from ECM</p> <p>Carefully remove yellow lock from header at device output terminal</p> <p>CAREFULLY check resistance between TPS2 input at ECM header and signal at device.</p> <p>NOTE: DO NOT INSERT probe or object into terminals as this will cause the terminal to spread and may no longer make contact with ECM pins. Spread pins will void warranty! Probe on the side of terminal.</p> | Is the resistance <5 ohms? | Go to Step (10) | Go to Step (11) |
| 10 | <p>Reconnect header to ECM</p> <p>Key On, Engine Off</p> <p>System Mode="Stopped"</p> <p>Probe TIP signal circuit with a test light connected to battery voltage</p> | Does DST display TIP voltage of 4.0 VDC or greater? | Go to Step (12) | Go to Step (13) |
| 11 | Faulty Harness | | | |
| 12 | <p>Faulty ECM connection</p> <p>Faulty ECM (analog input circuit)</p> | | | |
| 13 | <p>TIP signal shorted to ground</p> <p>Faulty ECM connection</p> <p>Faulty ECM (analog input circuit)</p> | | | |

DTC 238 - TIP/TOP High Voltage

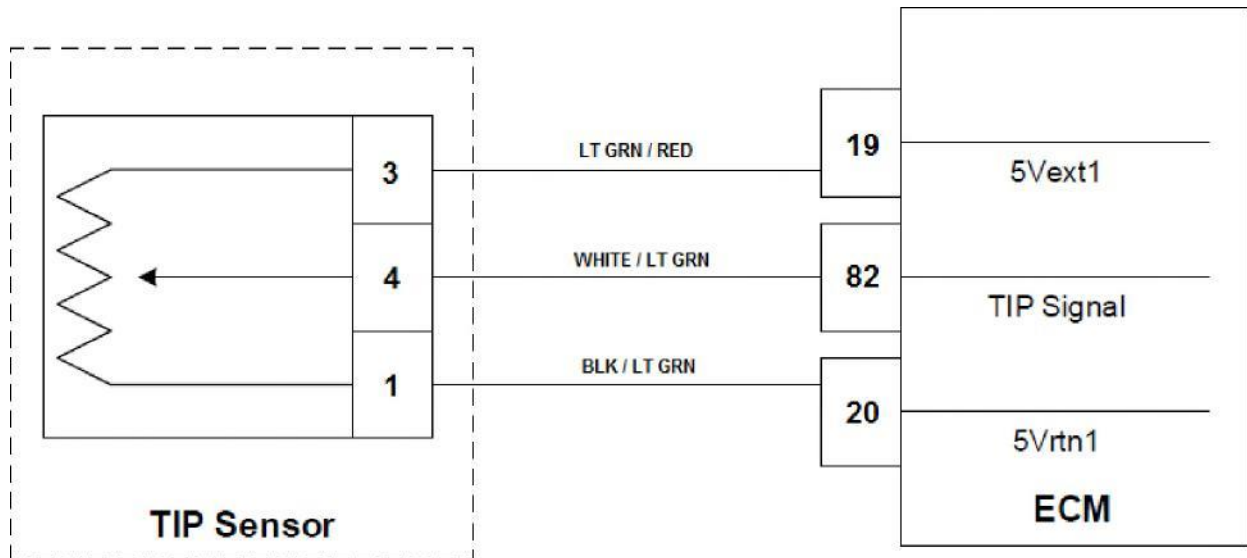

Conditions for Setting the DTC

- Throttle Inlet Pressure
- Check Condition: Key On, Engine Off
- Fault Condition: TIP voltage greater than 4.8V
- MIL on
- Adaptive disabled

Fault Description

The engine uses a throttle inlet pressure (TIP) sensor upstream of the throttle valve to monitor incoming throttle pressure. This fault will set when the TIP sensor voltage feedback is sensed as higher than the sensor should normally produce as set in the diagnostic calibration.

Diagnosing the Fault

In many cases, this condition is caused by the TIP circuit being shorted to a voltage source or a failure of the sensor.

DTC 238 - TIP/TOP High Voltage

| Step | Action | Value(s) | Yes | No |
|------|--|---|----------------|--------------------------------|
| 1 | Did you perform the On-Board (OBD) System Check? | - | Go to Step (2) | Go to OBD System Check Section |
| 2 | Key ON, Engine On System Mode = "Running" | Does DST display TIP pressure greater than that defined in the diagnostic calibration with the engine idling? | Go to Step (3) | Go to Step (4) |
| 3 | Key Off Disconnect TIP sensor from harness Key On, Engine off System Mode = "Stopped" | Does DST display TIP voltage <0.100 VDC? | Go to Step (5) | Go to Step (6) |
| 4 | Intermittent Problem | | | |
| 5 | Probe sensor ground circuit with test light connected to battery voltage | Does test light come on? | Go to Step (7) | Go to Step (8) |
| 6 | TIP signal circuit shorted to voltage Faulty sensor Faulty ECM | | | |
| 7 | Faulty TIP sensor Faulty ECM connector | | | |
| 8 | Open sensor ground circuit Faulty ECM | | | |

DTC 326 - Knock 1 Excessive Signal

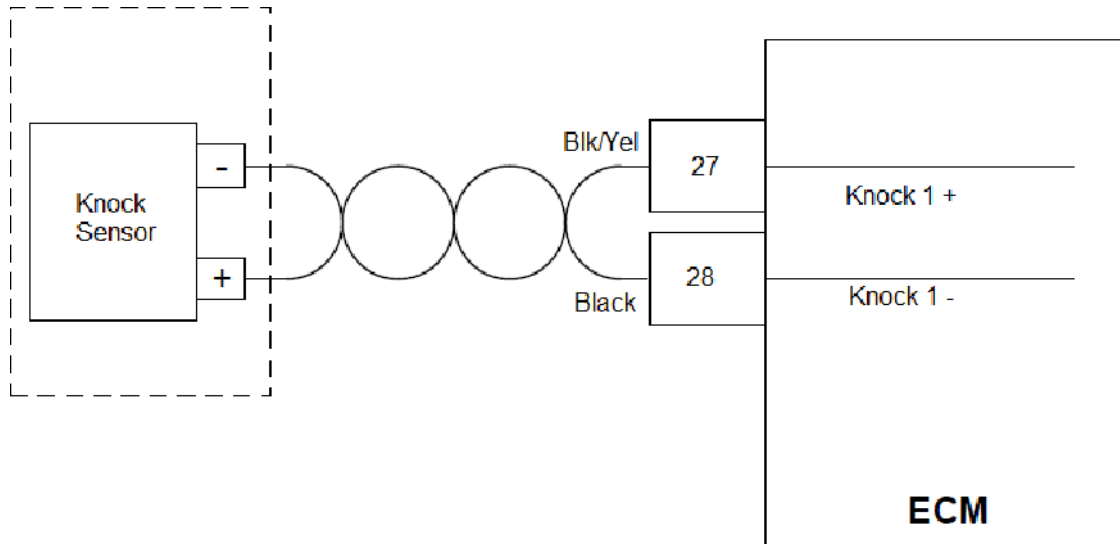

Conditions for Setting the DTC

- Check Condition: Key On, Engine Running
- Fault Condition: With MAP below 10 psia, knock sensor input voltage is greater than 4V for 3 seconds
- MIL: ON during active fault
- Engine Shutdown

Fault Description

The knock sensor is used to detect detonation through mechanical vibration in the engine block and/or cylinder heads and provide feedback for the ignition system to retard spark timing to reduce knock intensity. In most applications the knock sensor is used to protect the engine from damage that can be caused from detonation or knock based on fixed spark advance. This fault sets if the signal from knock sensor 1 is higher than expected for low load operation. If the fault sets, the MIL light is active, and the engine will shut down.

DTC 326 - Knock 1 Excessive Signal

Note:

∇ Verify all knock sensors are torqued properly before proceeding with the below steps and recheck.

| Step | Action | Value(s) | Yes | No |
|------|--|--|-----------------|--------------------------------|
| 1 | Did you perform the On-Board (OBD) System Check? | - | Go to Step (2) | Go to OBD System Check Section |
| 2 | Key ON, Engine Running System Mode = "Running" | | | |
| 3 | Operate engine at the condition that generated the fault as indicated in fault snapshot. Verify the DTC 326 is active/. | | | |
| 4 | Disconnect ect knock sensor 1 from wire harness | | | |
| 5 | Operate engine at the condition that generated the fault as indicated in fault snapshot. | | Go to Step (6) | Go to Step (7) |
| 6 | Key ON, Engine Off System Mode = "Running" | Using a DVOM, is the voltage potential between knock 1+ and Vbat >80% of Vbat? | Go to Step (8) | Go to Step (9) |
| 7 | Faulty Sensor, replace | | | |
| 8 | Disconnect wire harness header from ECM | Using a DVOM, is the voltage potential between knock 1+ and Vbat >80% of Vbat? | Go to Step (10) | Go to Step (11) |
| 9 | Possible faulty sensor Intermittent fault | | | |
| 10 | Possible faulty ECM | | | |
| 11 | Faulty wire harness | | | |

DTC 327 – Knock 1 Sensor Open

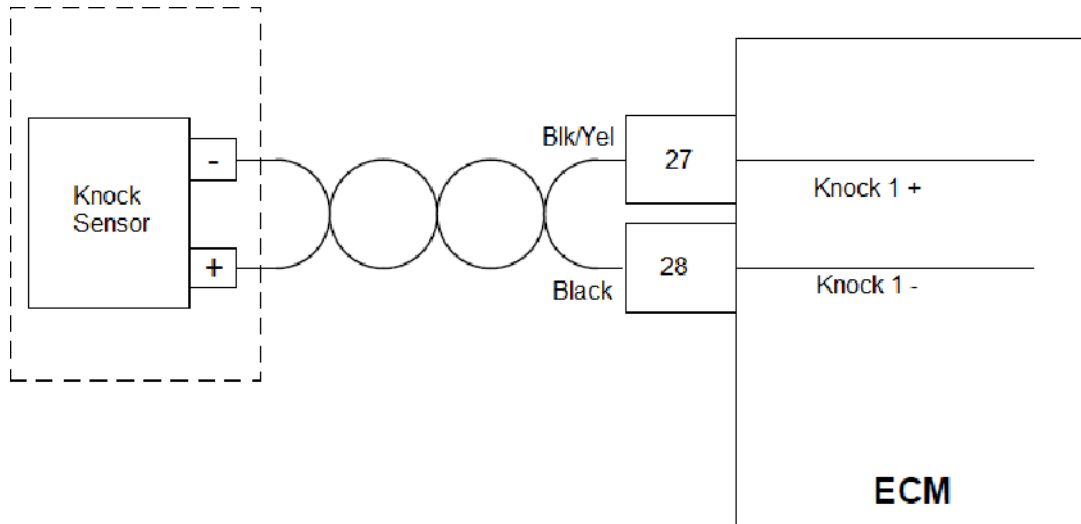

Conditions for Setting the DTC

- Check Condition: Key On, Engine Running
- Fault Condition: With MAP below 10 psia, knock sensor input voltage is less than 0.001V for 3 seconds
- MIL: ON during active fault
- Engine Shutdown

Fault Description

The knock sensor is used to detect detonation through mechanical vibration in the engine block and/or cylinder heads and provide feedback for the ignition system to retard spark timing to reduce knock intensity. In most applications the knock sensor is used to protect the engine from damage that can be caused from detonation or knock based on fixed spark advance. This fault sets if the signal from knock sensor 1 is lower than expected for low load operation. If the fault sets, the MIL light is active and the engine will shut down.

DTC 327 – Knock I Sensor Open

| Step | Action | Value(s) | Yes | No |
|------|--|---|-----------------|--------------------------------|
| 1 | Did you perform the On-Board (OBD) System Check? | - | Go to Step (2) | Go to OBD System Check Section |
| 2 | Key ON, Engine Running System Mode = “Running” | | | |
| 3 | Operate engine at the minimum RPM and MAP defined in diagnostic calibration for the knock sensor open fault | Does DTC 327 reset? | Go to Step (4) | Go to Step (5) |
| 4 | Key Off Disconnect knock sensor from wire harness | | | Go to Step (6) |
| 5 | Intermittent Problem | | | |
| 6 | Disconnect wire harness header from ECM Carefully remove yellow lock from header at device output terminal CAREFULLY check resistance between Knock 1 (+) output at ECM header and knock sensor connector. NOTE: DO NOT INSERT probe or object into terminals as this will cause the terminal to spread and may no longer make contact with ECM pins. Spread pins will void warranty! Probe on the side of terminal. | Does DMM indicate a resistance <5.0 ohms? | Go to Step (7) | Go to Step (8) |
| 7 | Check resistance between Knock 1 (+) and ground and 5Vrtn1 (Analog Return) | Does DMM indicate a resistance <5.0 ohms? | Go to Step (9) | Go to Step (10) |
| 8 | Faulty harness (open circuit) | | | |
| 9 | Faulty harness (ground short) | | | |
| 10 | Inspect knock wiring in harness | Is wiring properly twisted? | Go to Step (11) | Go to Step (12) |
| 11 | Faulty sensor (replace and retest) Faulty ECM | | | |

| | | | | |
|----|----------------|--|--|--|
| 12 | Faulty Harness | | | |
|----|----------------|--|--|--|

DTC 336 - Crank Sync Noise

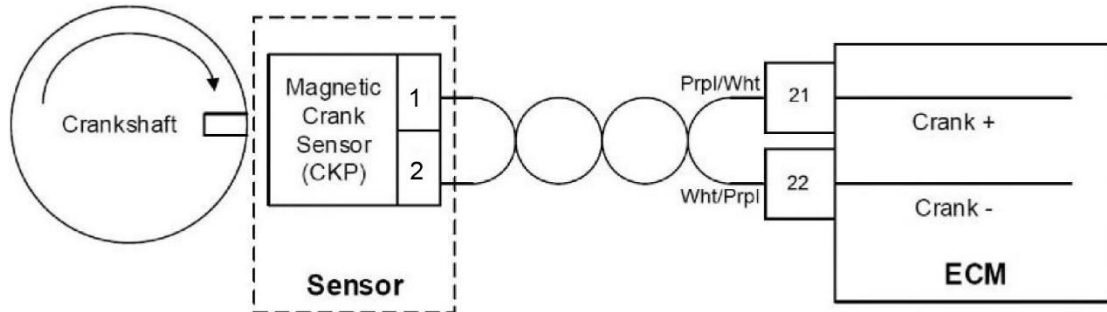

Conditions for Setting the DTC

- Check Condition: Key On, Engine Running
- Fault Condition: 1 invalid resync within a time window of 800 milliseconds
- MIL: ON during active fault
- Adaptive learn disabled

Fault Description

The crankshaft position sensor is a magnetic sensor installed on the engine adjacent to a "coded" trigger wheel located on the vibration dampener. The sensor-trigger wheel combination is used to determine crankshaft position (with respect to TDC cylinder #1 compression) and the rotational engine speed. Determination of the crankshaft position and speed is necessary to properly activate the ignition, fuel injection, and throttle governing systems for precise engine control.

The ECM must see a valid crankshaft position while running. If no signal is present, the signal amplitude is too high (due to improper air gap with respect to trigger wheel), or an irregular crank pattern is detected causing the ECU to resynchronize more than once in 800 milliseconds, the fault will set. Irregular crank patterns can be detected by the ECM due to electrical noise, poor machining of the trigger wheel, or trigger wheel runout and/or gear lash.

DTC 336 - Crank Sync Noise

| Step | Action | Value(s) | Yes | No |
|------|--|--|-----------------|--------------------------------|
| 1 | Did you perform the On-Board (OBD) System Check? | - | Go to Step (2) | Go to OBD System Check Section |
| 2 | Key ON, Engine Running System Mode = "Running" | | Go to Step (3) | |
| 3 | Operate engine at condition that set the fault based on fault snapshot. | Does DTC 336 reset? | Go to Step (4) | Go to Step (5) |
| 4 | - | Is crank sensor a VR/magnetic pick-up? | Go to Step (6) | Go to Step (7) |
| 5 | Intermittent fault | | | |
| 6 | - | Is wiring between sensor and ECM properly twisted? | Go to Step (10) | Go to Step (11) |
| 7 | Check wiring and electrical connections between crankshaft position sensor and ECM | Is the wiring, OK? | Go to Step (8) | Go to Step (9) |
| 8 | Poor system ground Bad crankshaft position sensor Bad ECM | | | |
| 9 | Repair wire harness | | | |
| 10 | - | Does fault only occur at high operating speeds? | Go to Step (12) | Go to Step (13) |
| 11 | Faulty wire harness (twist circuit) | | | |
| 12 | Increase the air gap between sensor and trigger wheel | | | |

| Step | Action | Value(s) | Yes | No |
|-------------|--|-----------------|-----------------|-----------------|
| 13 | Check wiring and electrical connections between crankshaft position sensor and ECM | Is wiring OK? | Go to Step (14) | Go to Step (15) |
| 14 | Repair wire harness | | | |
| 15 | Poor system ground Bad crankshaft position sensor Bad ECM | | | |

DTC 337 - Loss of Crankshaft Signal

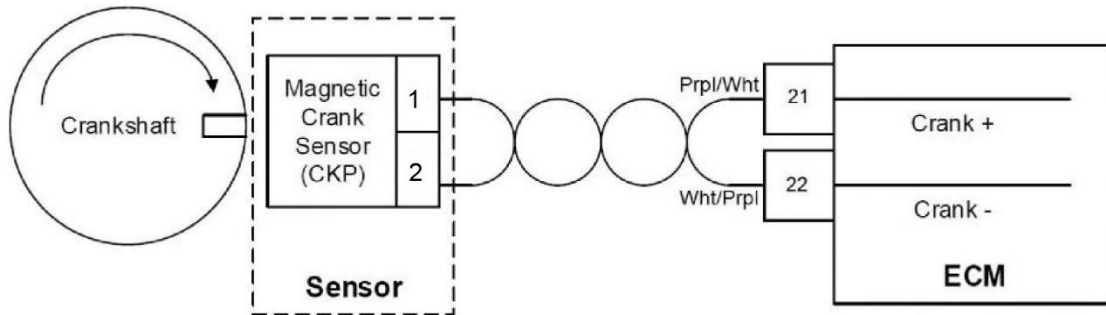

Conditions for Setting the DTC

- Check Condition: Key On, Engine Running
- Fault Condition: ECM sees six cam pulses without crank activity
- MIL: ON during active fault
- Engine shutdown

Fault Description

The crankshaft position sensor is a magnetic sensor installed on the engine adjacent to a "coded" trigger wheel located on the vibration dampener. The sensor-trigger wheel combination is used to determine crankshaft position (with respect to TDC cylinder #1 compression) and the rotational engine speed. Determination of the crankshaft position and speed is necessary to properly activate the ignition, fuel injection, and throttle governing systems for precise engine control.

The ECM must see a valid crankshaft position while running. If no signal is present while six cam pulses continue the fault will set. The MIL will come on and the engine will shut down.

Diagnostic Aids

- Check that the crankshaft position sensor is securely connected to harness
- Check that the crankshaft position sensor is securely installed in bracket, and bracket is tight and properly aligned with the crankshaft position wheel
- Check crankshaft position sensor circuit wiring for open circuit

DTC 341 - Cam Input Signal Noise

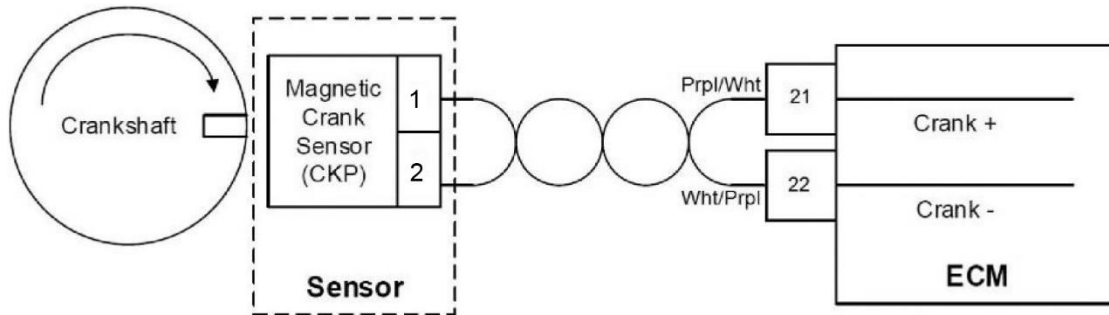

Conditions for Setting the DTC

- Check Condition: Key On, Engine Running
- Fault Condition: 1 invalid resyncs in 700 milliseconds
- MIL: ON during active fault
- Adaptive learn disabled

Fault Description

The camshaft position sensor is a magnetic sensor installed in the engine block adjacent to a "coded" trigger wheel. The sensor-trigger wheel combination is used to determine cam position with respect to TDC #1 compression. Determination of the camshaft position is necessary to identify the stroke (or cycle) of the engine to properly activate the ignition for precise engine control.

For a cam synchronized engine, the ECM must see a valid camshaft position signal while running. If no signal is present, the signal amplitude is too high (due to improper air gap with respect to the trigger wheel), or an irregular cam pattern is detected causing the ECM to resynchronize once in 700 milliseconds, this fault will set. Irregular cam patterns can be detected by the ECM due to electrical noise, poor machining of the trigger wheel, or trigger wheel runout and/or gear lash. When the fault is set the MIL will light and the engine will not enter adaptive learn mode. In some instances, this fault can cause rough engine operation and can cause the engine to stall and die if equipped with a coil-on-plug ignition system.

DTC 341 - Cam Input Signal Noise

| Step | Action | Value(s) | Yes | No |
|------|--|--|-----------------|--------------------------------|
| 1 | Did you perform the On-Board (OBD) System Check? | - | Go to Step (2) | Go to OBD System Check Section |
| 2 | Key ON, Engine Running System Mode = "Running" | | Go to Step (3) | |
| 3 | Operate engine at condition that set the fault based on fault snapshot. | Does DTC 341 reset? | Go to Step (4) | Go to Step (5) |
| 4 | - | Is cam sensor a VR/magnetic pick-up? | Go to Step (6) | Go to Step (7) |
| 5 | Intermittent fault | | | |
| 6 | - | Is wiring between sensor and ECM properly twisted? | Go to Step (10) | Go to Step (11) |
| 7 | Check wiring and electrical connections between camshaft position sensor and ECM | Is the wiring, OK? | Go to Step (8) | Go to Step (9) |
| 8 | Poor system ground Bad camshaft position sensor Bad ECM | | | |
| 9 | Repair wire harness | | | |
| 10 | - | Does fault only occur at high operating speeds? | Go to Step (12) | Go to Step (13) |
| 11 | Faulty wire harness (twist circuit) | | | |
| 12 | Increase the air gap between sensor and trigger wheel | | | |

| Step | Action | Value(s) | Yes | No |
|-------------|--|-----------------|-----------------|-----------------|
| 13 | Check wiring and electrical connections between camshaft position sensor and ECM | Is wiring OK? | Go to Step (14) | Go to Step (15) |
| 14 | Repair wire harness | | | |
| 15 | Poor system ground Bad camshaft position sensor Bad ECM | | | |

DTC 342 - Loss of Camshaft Input Signal

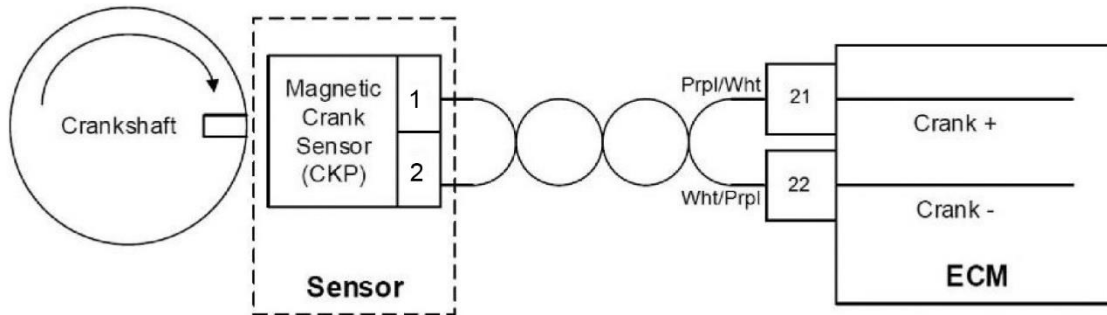

Conditions for Setting the DTC

- Check Condition: Key On, Engine Running
- Fault Condition: No cam pulses in 2.5 engine cycles with engine RPM > 1000
- MIL: ON during active fault
- Engine shutdown

Fault Description

The camshaft position sensor is a magnetic sensor installed in the engine block adjacent to a "coded" trigger wheel. The sensor-trigger wheel combination is used to determine cam position with respect to TDC #1 compression. Determination of the camshaft position is necessary to identify the stroke (or cycle) of the engine to properly activate the ignition for precise engine control.

For a cam synchronized engine, the ECM must see a valid camshaft position signal while running. This fault will set if valid crankshaft position data is received for 2.5 engine cycles with an engine speed greater than 1000 RPM and no camshaft signal is received. The MIL will light and the engine will shut down.

Diagnostic Aids

- Check that the camshaft position sensor is securely connected to harness
- Check that the camshaft position sensor is securely installed, and bracket (if used) is tight and properly aligned with the crankshaft position wheel.
- Check camshaft position sensor circuit wiring for open circuit

DTC 520 - Oil Pressure Low Stage 1

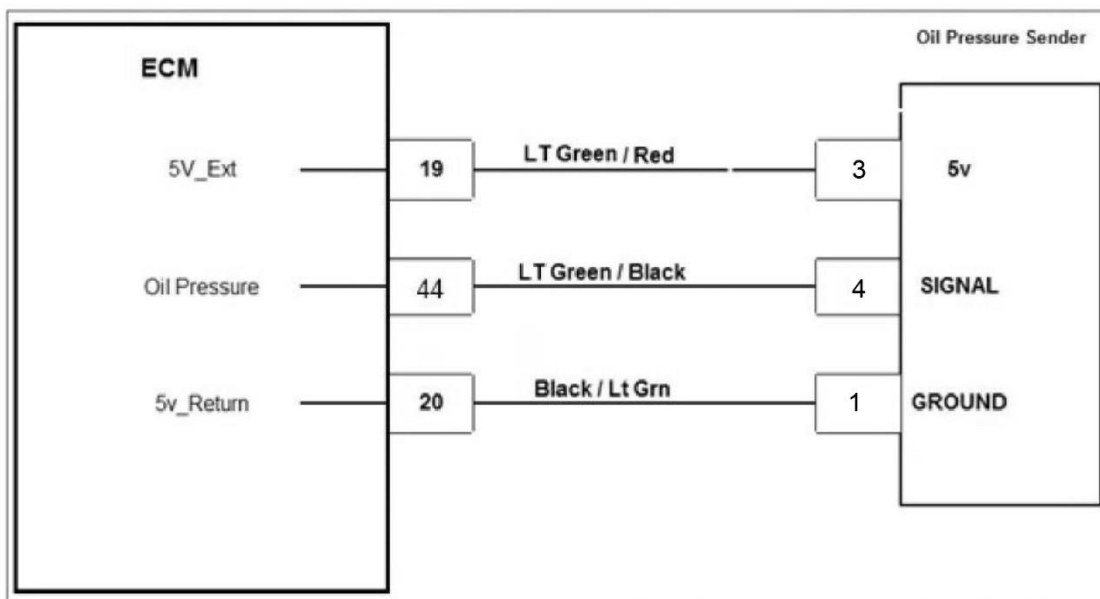

Conditions for Setting the DTC

- Engine Oil Pressure low.
- Check Condition: Engine running for 5 seconds or more with engine speed greater than 600 rpm.
- Fault Condition: Oil pressure less than 15 PSI if engine speed is less than 1,400rpm
- Fault Condition: Oil pressure less than 30 PSI if engine speed is greater than 1,450rpm
- MIL is illuminated

Circuit Description

The Oil Pressure Sender is used to communicate the oil pressure condition to the ECM. Engine damage can occur if the engine is operated with low oil pressure. The ECM sends a 5v signal to the oil pressure sender. The sender will report a signal back to the ECM on the signal wire depending on the pressure that is applied on its diaphragm. The voltage is linear in comparison to the pressure applied (see chart below). The MIL command is ON and the engine will shut down in the event of this fault to help prevent possible engine damage.

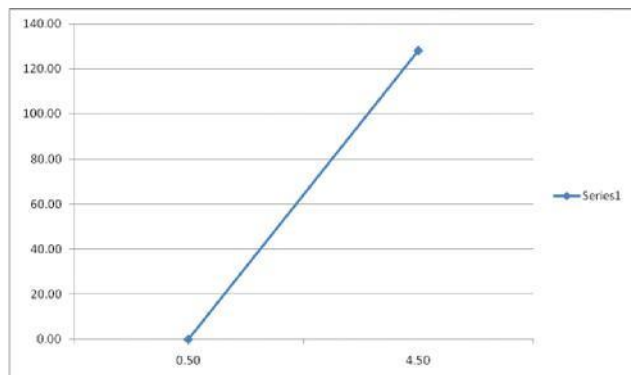

| Code # | Code Name | RPM | Pressure |
|--------|----------------------|----------|----------|
| 520 | Oil Pres Low Stage 1 | <= 1,400 | 15 psi |
| 520 | Oil Pres Low Stage 1 | >= 1,450 | 30 psi |
| 524 | Oil Pres Low Stage 2 | <= 1,400 | 8 psi |
| 524 | Oil Pres Low Stage 2 | >= 1,450 | 25 psi |

DTC 520 - Oil Pressure Low Stage 1

Note:

If both oil pressure sensors (Master and slave side) are reading zero and are not showing pressure, DO NOT continue to crank the engine repeatedly.

| Step | Action | Value(s) | Yes | No |
|------|--|----------|--|--|
| 1 | Did you perform the On-Board (OBD) System Check? | - | Go to Step (2) | Go to OBD System Check Section |
| 2 | Verify that the engine has oil pressure using a mechanical oil pressure gauge before proceeding with this chart. Does the engine have oil pressure above 8 psi? | 8 psi | Go to Step (3) | Repair faulty Oiling System |
| 3 | Key ON, Engine Running DST connected in System Data Mode Clear DTC 520 Warm the engine by idling until the ECT temperature is above 160 degrees F. and has been running for at least 5 seconds or more. Does DTC 520 become active? | | Go to Step (4) | Intermittent problem Go to Intermittent section |
| 4 | With a voltmeter, check terminal B on the sensor for a 5 volt reference from the ECM. Do you have 5 volts on terminal 3? | 5v | Go to Step (6) | Go to Step (5) |
| 5 | With a voltmeter, check terminal 19 on the ECM for a 5 volt reference. Do you have a 5v reference coming out of the ECM? | 5v | Repair faulty wiring between ECM and Oil pressure sensor | Go to Step (8) |
| 6 | With the oil pressure sender connected check for a signal coming out of terminal 4. Do you have a voltage signal coming out of terminal 4? | | Go to Step (7) | Replace faulty oil pressure sender |
| 7 | With the oil pressure sender connected check for a signal at terminal 44 of the ECM. Do you have a signal voltage at pin 44 of the ECM that matches the voltage at terminal 4 of the oil pressure sensor? | | Go to Step (8) | Repair faulty wiring between terminal C and Terminal 25. |
| 8 | Replace ECM Is the replacement complete? | | Go to Step (9) | - |

| Step | Action | Value(s) | Yes | No |
|------|---|----------|-----------|------------------------|
| 9 | Remove all test equipment except the DST. Connect any disconnected components, fuses, etc. Using the DST clear DTC information from the ECM. Turn the ignition OFF and wait 30 seconds. Start the engine and operate the vehicle to full operating temperature Observe the MIL Observe engine performance and drivability After operating the engine within the test parameters of DTC-520 check for any stored codes. Does the engine operate normally with no stored codes? | | System OK | Go to OBD System Check |

DTC 522 - Oil Pressure Sender low voltage

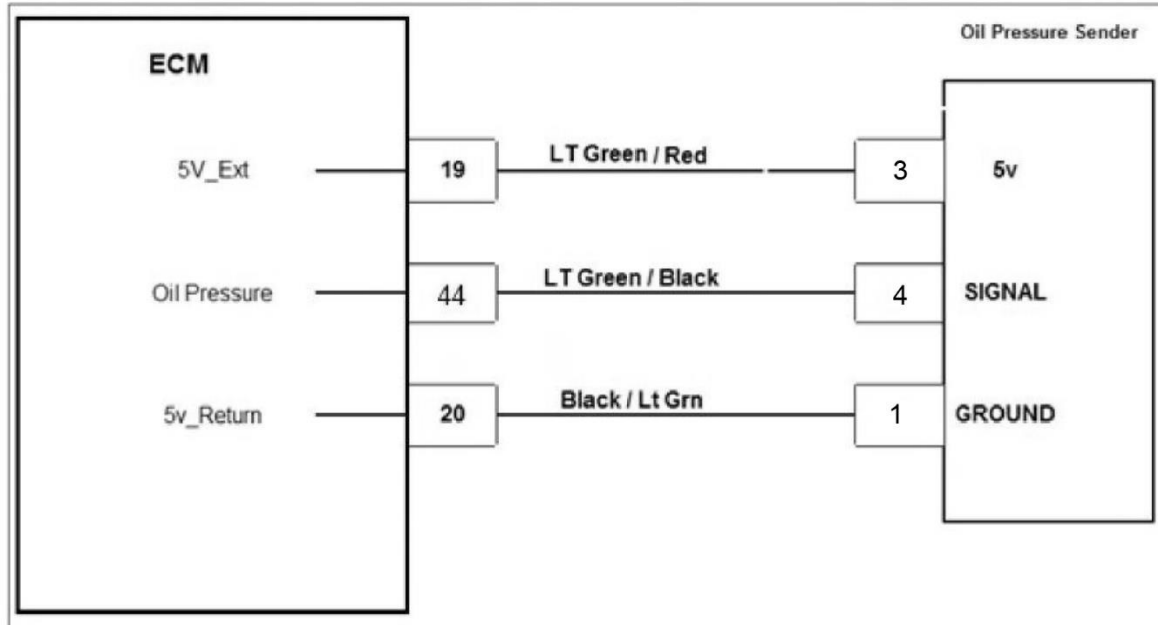

Conditions for Setting the DTC

- Check Condition: Engine running for 20 seconds or more with engine speed greater than 600 rpm.
- Fault Condition: Voltage on terminal 44 is less than 0.2v for more than 1 second
- MIL: ON during active fault and for 2 seconds after active fault.

Circuit Description

The Oil Pressure Sender is used to communicate the oil pressure condition to the ECM. Engine damage can occur if the engine is operated with low oil pressure. The ECM sends a 5v signal to the oil pressure sender. The sender will report a signal back to the ECM on the signal wire depending on the pressure that is applied on its diaphragm. The voltage is linear in comparison to the pressure applied (see chart below). The MIL command is ON and the engine will shut down in the event of this fault to help prevent possible engine damage.

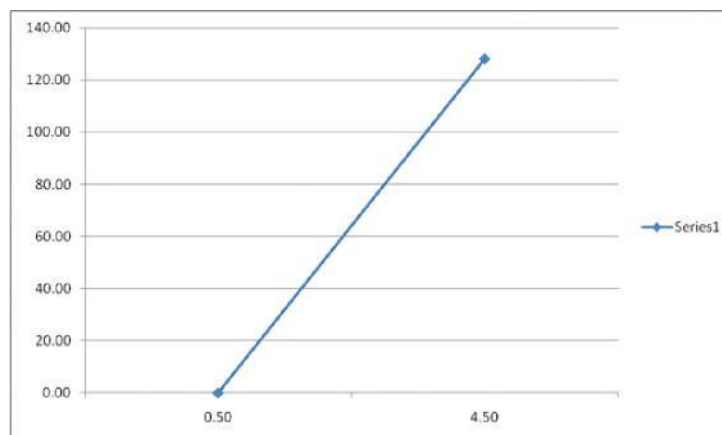

DTC 522 - Oil Pressure Sender low voltage

| Step | Action | Value(s) | Yes | No |
|------|--|---|----------------|--------------------------------|
| 1 | Did you perform the On-Board (OBD) System Check? | - | Go to Step (2) | Go to OBD System Check Section |
| 2 | Key ON, Engine Running System Mode = "Running" | Does DST display Oil Pressure voltage less than the limit defined in calibration? | Go to Step (3) | Go to Step (4) |
| 3 | Key Off Disconnect Oil Pressure from harness Key On, Engine Off System Mode="Stopped" | Does DTC display Oil Pressure voltage of 4.90 VDC or greater? | Go to Step (5) | Go to Step (6) |
| 4 | Intermittent problem | | | |
| 5 | Faulty Oil Pressure sensor | | | |
| 6 | Sensor signal circuit shorted to ground, check wire harness for ground short Faulty ECM | | | |

DTC 523 - Oil Pressure Sender high voltage

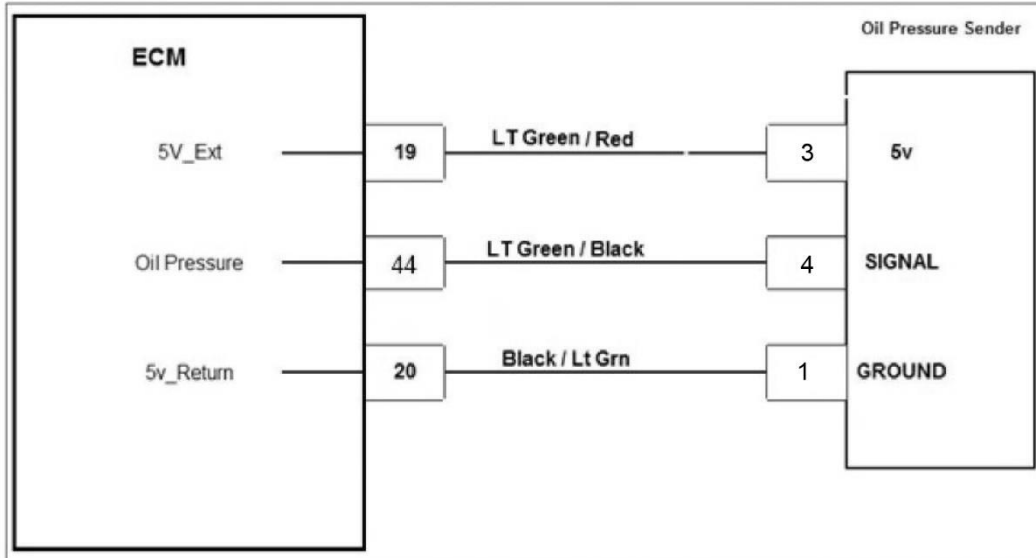

Conditions for Setting the DTC

- Check Condition: Engine running for 20 seconds or more with engine speed greater than 600 rpm.
- Fault Condition: Voltage on terminal 44 is greater than 4.8v for more than 1 second
- MIL: ON during active fault and for 2 seconds after active fault.
- Engine Shutdown

Circuit Description

The Oil Pressure Sender is used to communicate the oil pressure condition to the ECM. Engine damage can occur if the engine is operated with low oil pressure. The ECM sends a 5v signal to the oil pressure sender. The sender will report a signal back to the ECM on the signal wire depending on the pressure that is applied on its diaphragm. The voltage is linear in comparison to the pressure applied (see chart below). The MIL command is ON and the engine will shut down in the event of this fault to help prevent possible engine damage.

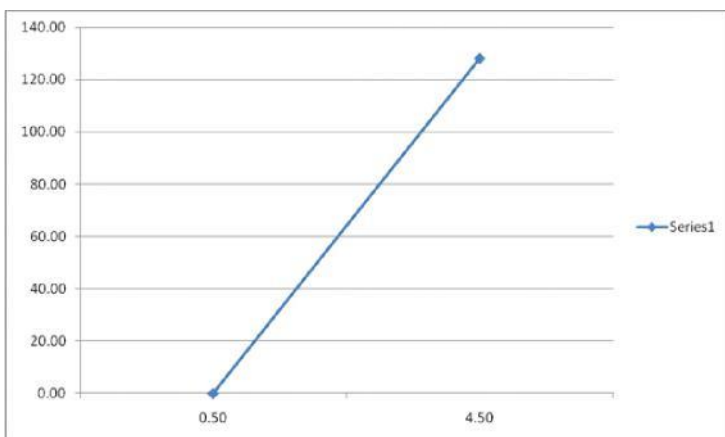

OTC 523 - Oil Pressure Sender High Voltage

| Step | Action | Value(s) | Yes | No |
|------|---|---|----------------|--------------------------------|
| 1 | Did you perform the On-Board (OBD) System Check? | - | Go to Step (2) | Go to OBD System Check Section |
| 2 | Key ON, Engine On System Mode = "Running" | Does the DST display Oil Pressure voltage greater than that defined in the recorded in the diagnostic calibration with engine idling? | Go to Step (3) | Go to Step (4) |
| 3 | Key Off Disconnect Oil Pressure sensor from harness Key On, Engine Off System Mode="Stopped" | Does DTC display Oil Pressure voltage of 4.90 VDC or greater? | Go to Step (6) | Go to Step (7) |
| 4 | Operate at an engine speed equal to or greater than that recorded when the fault previously set based on the fault snapshot | Does DST display Oil Pressure voltage greater than that defined in the diagnostic calibration? | Go to Step (3) | Go to Step (5) |
| 5 | Intermittent Problem | | | |
| 6 | Jumper Oil Pressure signal circuit to 5Vrtn 1 (Analog Return) | Does DST display Oil Pressure voltage <0.1 VDC? | Go to Step (8) | Go to Step (9) |
| 7 | Oil Pressure signal circuit short to ground Faulty ECM | | | |

| Step | Action | Value(s) | Yes | No |
|------|---|---|-----------------|-----------------|
| 8 | Jumper Oil Pressure signal circuit to ground | Does DST display Oil Pressure voltage <0.1 VDC? | Go to Step (10) | Go to Step (11) |
| 9 | Faulty connection to sensor Faulty Oil Pressure sensor | | | |
| 10 | Open Oil Pressure ground (5Vtrn1) circuit Faulty connection to sensor Faulty Oil Pressure sensor | | | |
| 11 | Key Off Disconnect wire harness header from ECM Carefully remove yellow lock from header at device output terminal CAREFULLY check resistance between Knock 1 (+) output at ECM header and knock sensor connector. NOTE: DO NOT INSERT probe or object into terminals as this will cause the terminal to spread and may no longer make contact with ECM pins. Spread pins will void warranty! Probe on the side of terminal. | Is the resistance <5 ohms? | Go to Step (12) | Go to Step (13) |
| 12 | Faulty ECM connection Faulty ECM | | | |
| 13 | Faulty Harness | | | |

DTC 524 - Oil Pressure Low Stage 2

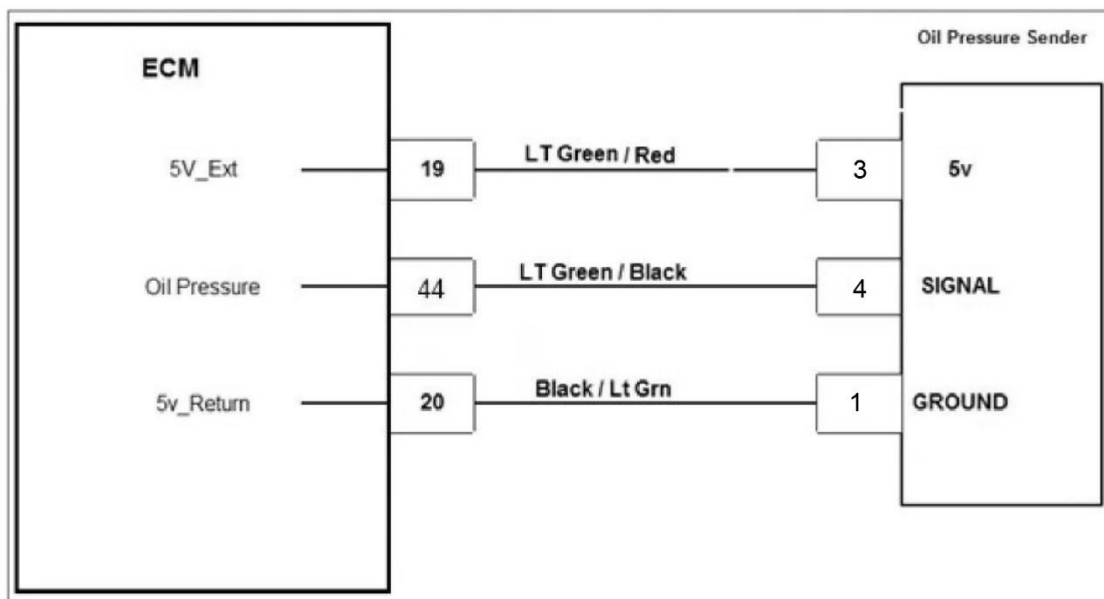

Conditions for Setting the DTC

- Engine Oil Pressure low.
- Check Condition: Engine running for 20 seconds or more with engine speed greater than 600 rpm.
- Fault Condition: Oil pressure less than 8 PSI with engine RPM less than 1,400rpm
- Fault Condition: Oil pressure less than 25psi with engine RPM greater than 1,450rpm
- Engine Shut Down.

Circuit Description

The Oil Pressure Sender is used to communicate the oil pressure condition to the ECM. Engine damage can occur if the engine is operated with low oil pressure. The ECM sends a 5v signal to the oil pressure sender. The sender will report a signal back to the ECM on the signal wire depending on the pressure that is applied on its diaphragm. The voltage is linear in comparison to the pressure applied (see chart below). The MIL command is ON and the engine will shut down in the event of this fault to help prevent possible engine damage.

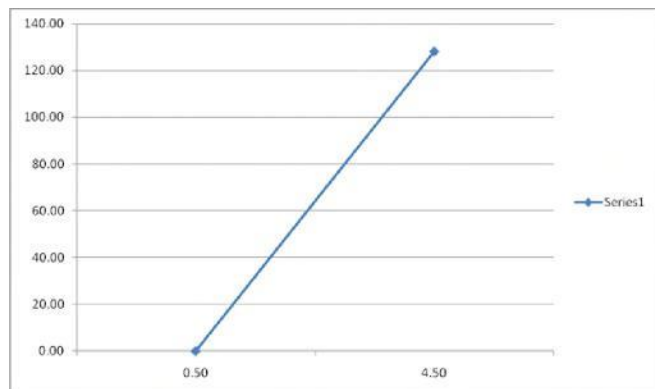

| Code # | Code Name | RPM | Pressure |
|--------|----------------------|----------|----------|
| 520 | Oil Pres Low Stage 1 | <= 1,400 | 15 psi |
| 520 | Oil Pres Low Stage 1 | >= 1,450 | 30 psi |
| 524 | Oil Pres Low Stage 2 | <= 1,400 | 8 psi |
| 524 | Oil Pres Low Stage 2 | >= 1,450 | 25 psi |

OTC 524 - Oil Pressure Low Stage 2

| Step | Action | Value(s) | Yes | No |
|------|--|----------|--|--|
| 1 | Did you perform the On-Board (OBD) System Check? | - | Go to Step (2) | Go to OBD System Check Section |
| 2 | Verify that the engine has oil pressure using a mechanical oil pressure gauge before proceeding with this chart. Does the engine have oil pressure above 8 PSI? | 8 PSI | Go to Step (3) | Repair faulty Oiling System |
| 3 | Key ON, Engine Running DST connected in System Data Mode Clear DTC 524 Warm the engine by idling until the ECT temperature is above 160 degrees F. and has been running for at least 20 seconds or more Does DTC 524 reset and cause the engine to shut down? | | Go to Step (4) | Intermittent problem Go to Intermittent section |
| 4 | With a volt meter, check terminal 3 on the sensor for a 5 volt reference from the ECM. Do you have 5 volts on terminal 3? | 5v | Go to Step (6) | Go to Step (5) |
| 5 | With a volt meter, check terminal 19 on the ECM for a 5 volt reference. Do you have a 5v reference coming out of the ECM? | 5v | Repair faulty wiring between ECM and Oil pressure sensor | Go to Step (<) |
| 6 | With the oil pressure sender connected check for a signal coming out of terminal 3. Do you have a voltage signal coming out of terminal 3? | | Go to Step (7) | Replace faulty oil pressure sender |
| 7 | With the oil pressure sender connected check for a signal at terminal 44 of the ECM. Do you have a signal voltage at pin 44 of the ECM? | | Go to Step (8) | Repair faulty wiring between terminal 3 and Terminal 25. |
| 8 | Replace DEPR / ECM Is the replacement complete? | | Go to Step (9) | - |

| Step | Action | Value(s) | Yes | No |
|------|---|----------|-----------|------------------------|
| 9 | <p>Remove all test equipment except the DST. Connect any disconnected components, fuses, etc.</p> <p>Using the DST clear DTC information from the ECM.</p> <p>Turn the ignition OFF and wait 30 seconds.</p> <p>Start the engine and operate the vehicle to full operating temperature</p> <p>Observe the MIL</p> <p>Observe engine performance and drivability</p> <p>After operating the engine within the test parameters of DTC-524 check for any stored codes.</p> <p>Does the engine operate normally with no stored codes?</p> | | System OK | Go to OBD System Check |

DTC 562 - System Voltage Low

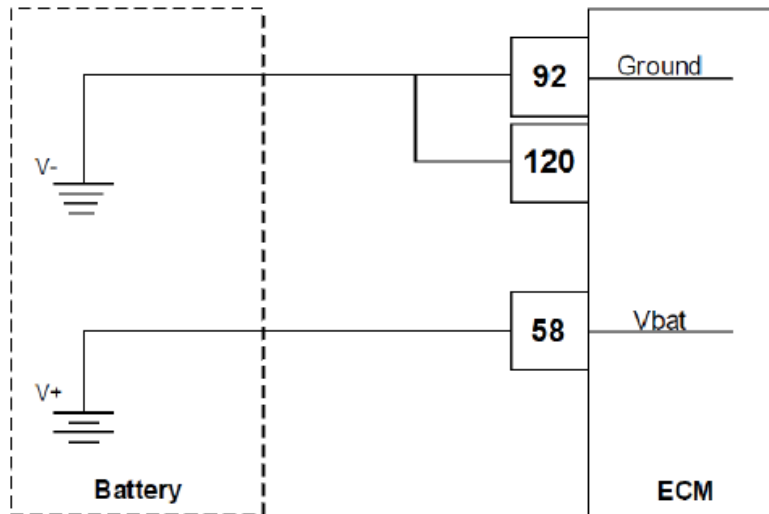

Conditions for Setting the DTC

- Check Condition: Key on with engine speed greater than 1000 RPM
- Fault Condition: Battery voltage at ECM less than 18.0
- Fault Condition is present for longer than 5 seconds.
- MIL: ON for active fault
- Adaptive: Disabled

Circuit Description

The battery voltage powers the ECM and must be measured to correctly to properly operate injector drivers, solenoid valves and ignition coils. This fault will set if the ECM detects system voltage less than 18.00 volts while the alternator should be charging. The adaptive learn is disabled during this fault.

DTC 562 - System Voltage Low

| Step | Action | Value(s) | Yes | No |
|------|--|---|----------------|--------------------------------|
| 1 | Did you perform the On-Board (OBD) System Check? | - | Go to Step (2) | Go to OBD System Check Section |
| 2 | Key ON, Engine On System Mode = "Running" Operate engine at Idle | | | |
| 3 | Check battery voltage in DST | Is battery voltage > low voltage limit is diagnostic limit in diagnostic condition? | Go to Step (4) | Go to Step (5) |
| 4 | Fault is Intermittent | | | |
| 5 | Using a DVM measure the voltage potential across battery (+) and (-) | Is battery voltage > low voltage limit is diagnostic limit in diagnostic condition? | Go to Step (6) | Go to Step (7) |
| 6 | Faulty Vbat power or ground circuit to ECM | | | |
| 7 | Faulty battery Faulty charging system Faulty ECM | | | |

DTC 563 - Battery Voltage High

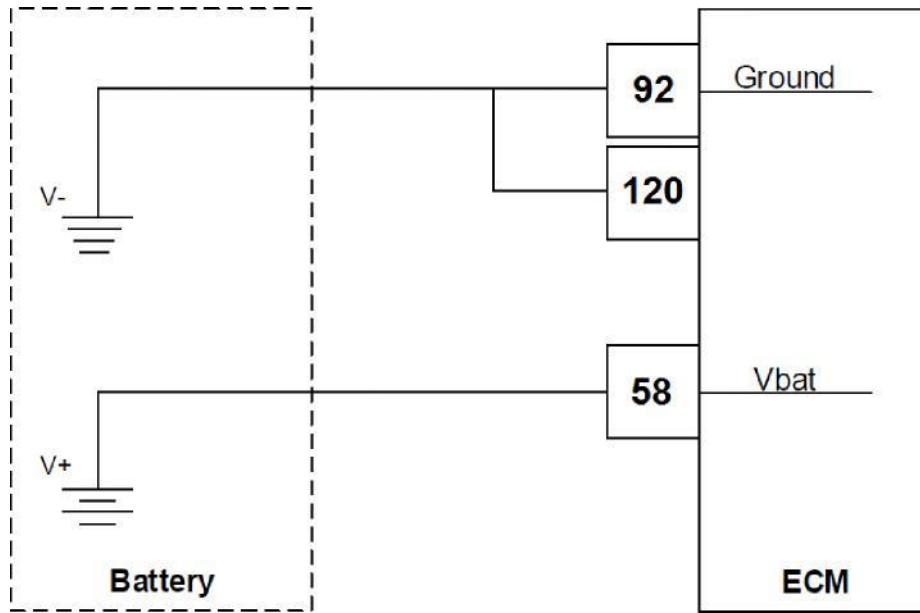

Conditions for Setting the DTC

- Check Condition: Key On, Engine cranking or running
- Fault Condition: Battery voltage exceeds 33V for 3 seconds
- MIL: ON during active fault
- Adaptive learn disabled

Fault Description

The battery voltage powers the ECM and must be within limits to correctly operate ignition coils, throttle, power supplies, and other powered devices that the ECM controls.

This fault will set if the ECM detects system voltage greater than 33V while the engine is running or cranking. The MIL will light and adaptive learn is disabled to avoid improper adaptive learning.

DTC 563 - Battery Voltage High

| Step | Action | Value(s) | Yes | No |
|------|--|--|----------------|--------------------------------|
| 1 | Did you perform the On-Board (OBD) System Check? | - | Go to Step (2) | Go to OBD System Check Section |
| 2 | Key ON, Engine On System Mode = "Running" Operate engine at Idle | | | |
| 3 | Check battery voltage in DST | Is battery voltage < high voltage limit in diagnostic condition? | Go to Step (4) | Go to Step (5) |
| 4 | Fault is Intermittent | | | |
| 5 | Using a DVM measure the voltage potential across battery (+) and (-) | Is battery voltage < high voltage limit in diagnostic condition? | Go to Step (6) | Go to Step (7) |
| 6 | Faulty ECM | | | |
| 7 | Key Off Disconnect wire harness header from ECM Using a DMM measure the voltage potential across battery (+) and (-) | Is battery voltage < high voltage limit in diagnostic condition? | Go to Step (8) | Go to Step (9) |
| 8 | Faulty charging system | | | |
| 9 | Faulty battery | | | |

DTC 601 - Flash Checksum Invalid

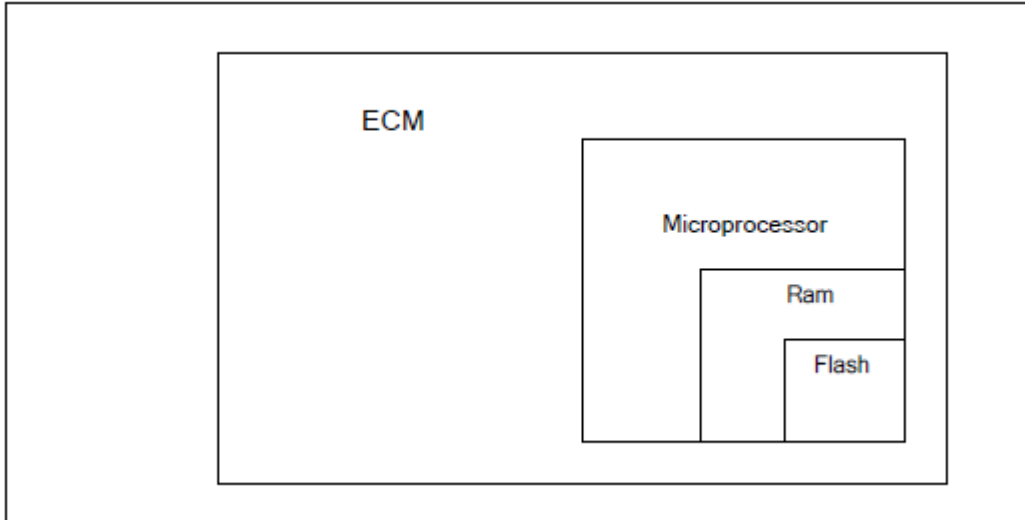

Conditions for Setting the DTC

- Check Condition: Key on
- Fault Condition: Internal microprocessor error
- MIL: ON
- Engine Shutdown will occur

Circuit Description

The ECM has several internal checks that must be satisfied each time an instruction is executed. Several different things can happen within the microprocessor that will cause this fault. The ECM will attempt to reset itself in the event this fault is set. The MIL command is on and will remain on until the code is cleared using the DST. The engine will shut down when this fault occurs.

DTC 601 - Flash Checksum Invalid

| Step | Action | Value(s) | Yes | No |
|------|--|---|----------------|--------------------------------|
| 1 | Did you perform the On-Board (OBD) System Check? | - | Go to Step (2) | Go to OBD System Check Section |
| 2 | Key ON, Engine On System Mode = "Running" Operate engine at Idle | | | |
| 3 | Clear system fault | Does DTC 601 reset with engine running? | Go to Step (4) | Go to Step (5) |
| 4 | Check all power and ground circuits to ECM | Are all circuits OK? | Go to Step (6) | Go to Step (7) |
| 5 | Fault is Intermittent | | | |
| 6 | Replace ECM with known good part and retest | | | |
| 7 | Repair wiring to ECM and retest | | | |

DTC 604 - RAM Failure

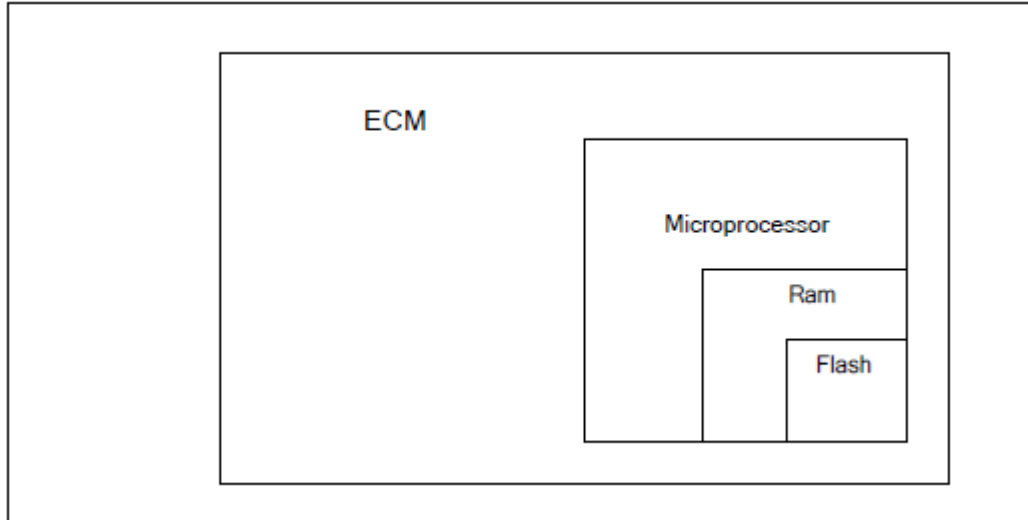

Conditions for Setting the DTC

- Check Condition: Key on
- Fault Condition: Internal microprocessor error
- MIL: ON
- Engine Shutdown will occur

Circuit Description

The ECM has several internal checks that must be satisfied each time an instruction is executed. Several different things can happen within the microprocessor that will cause this fault. The ECM will attempt to reset itself in the event this fault is set. The MIL command is on and will remain on until the code is cleared using the DST. The engine will shut down if this fault occurs.

DTC 604 - RAM Failure

| Step | Action | Value(s) | Yes | No |
|-------------|--|--|----------------|--------------------------------|
| 1 | Did you perform the On-Board (OBD) System Check? | - | Go to Step (2) | Go to OBD System Check Section |
| 2 | Key ON, Engine On System Mode = "Running" Operate engine at Idle | | | |
| 3 | Clear system fault | Does DTC 604 reset with engine idling? | Go to Step (4) | Go to Step (5) |
| 4 | Check all power and ground circuits to ECM | Are all circuits OK? | Go to Step (6) | Go to Step (7) |
| 5 | Fault is Intermittent | | | |
| 6 | Replace ECM with known good part and retest | | | |
| 7 | Repair wiring to ECM and retest | | | |

DTC 606 - COP Failure

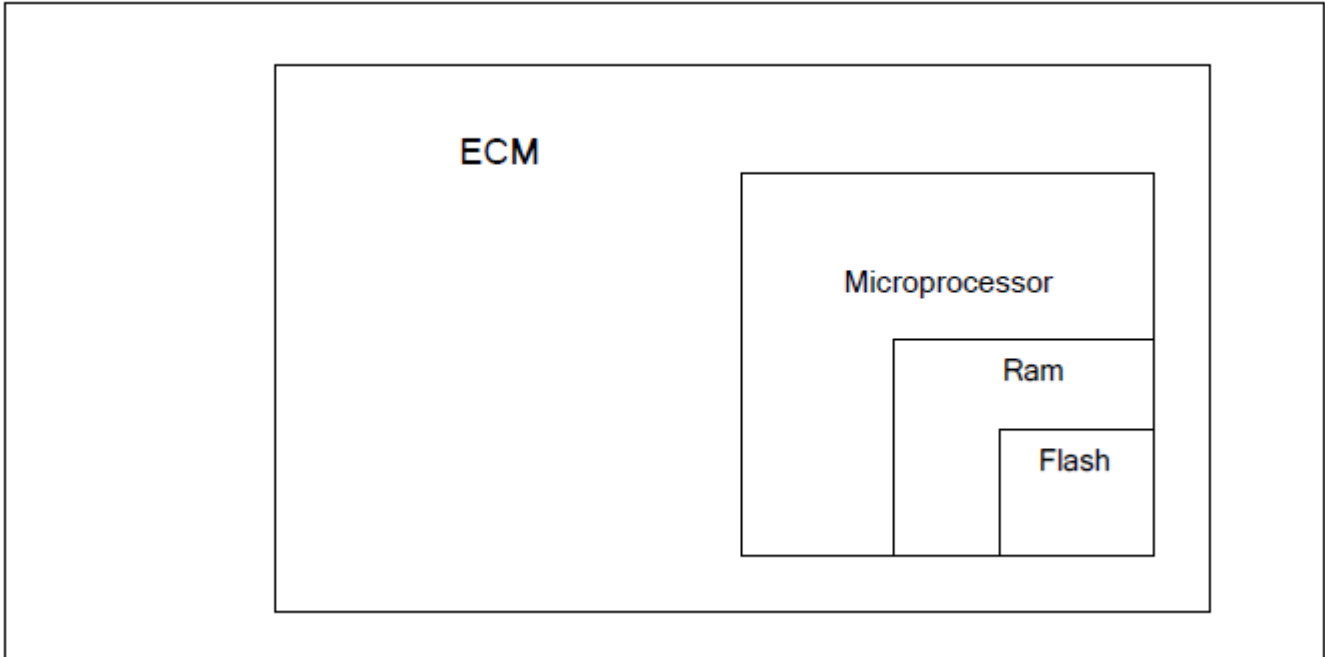

Conditions for Setting the DTC

- Check Condition: Key on
- Fault Condition: Internal microprocessor error
- MIL: ON
- Engine Shutdown will occur

Circuit Description

The ECM has several internal checks that must be satisfied each time an instruction is executed. Several different things can happen within the microprocessor that will cause this fault. The ECM will attempt to reset itself in the event this fault is set. The MIL command is on and will remain on until the code is cleared using the DST. The engine will shut down if this fault occurs.

DTC 606 - COP Failure

| Step | Action | Value(s) | Yes | No |
|-------------|--|--|----------------|--------------------------------|
| 1 | Did you perform the On-Board (OBD) System Check? | - | Go to Step (2) | Go to OBD System Check Section |
| 2 | Key ON, Engine On System Mode = "Running" Operate engine at Idle | | | |
| 3 | Clear system fault | Does DTC 606 reset with engine idling? | Go to Step (4) | Go to Step (5) |
| 4 | Check all power and ground circuits to ECM | Are all circuits OK? | Go to Step (6) | Go to Step (7) |
| 5 | Fault is Intermittent | | | |
| 6 | Replace ECM with known good part and retest | | | |
| 7 | Repair wiring to ECM and retest | | | |

DTC 642 - External 5 Volt 1 Reference Low

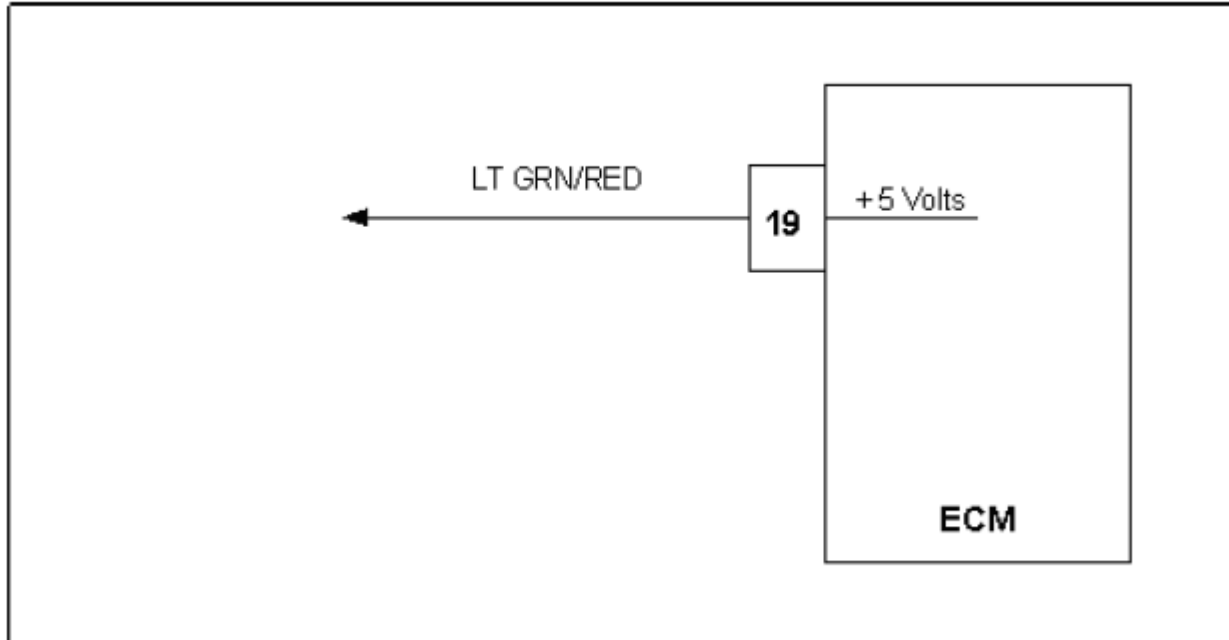

Conditions for Setting the DTC

- Check Condition: Engine cranking or running
- Fault Condition: 5 volt reference voltage lower than 4.60 volts
- MIL: ON during active fault
- Adaptive: Disabled during active fault

Circuit Description

The External 5 volt supply powers many of the sensors and other components of the fuel system. The accuracy of the 5 volt supply is very important to the accuracy of the powered sensors and fuel control by the ECM. The ECM is able to determine if they are overloaded, shorted, or otherwise out of specification by monitoring the 5 volt supply. This fault will set if the 5 volt reference is below 4.60 volts. Adaptive Learn will be disabled during this fault.

DTC 642 - External 5 Volt 1 Reference Low

| Step | Action | Value(s) | Yes | No |
|------|---|---|----------------|--------------------------------|
| 1 | Did you perform the On-Board (OBD) System Check? | - | Go to Step (2) | Go to OBD System Check Section |
| 2 | Key ON, Engine Running System Mode = "Running" | Does DTC display DTC 642? | Go to Step (3) | Go to Step (4) |
| 3 | - | Using DST, is 5Vext1 FB (VE5a_FB_r aw) * $11/10 < 0.10$ VDC? | Go to Step (5) | Go to Step (6) |
| 4 | Intermittent problem | | | |
| 5 | Wire connected to terminal # 19 at the ECM is partially or completely shorted to ground 5Vext is overloaded with too many sensors or faulty sensor | | | |
| 6 | 5Vext is overloaded with too many sensors or faulty sensor Faulty ECM | | | |

DTC 643 - External 5 Volt 1 Reference High

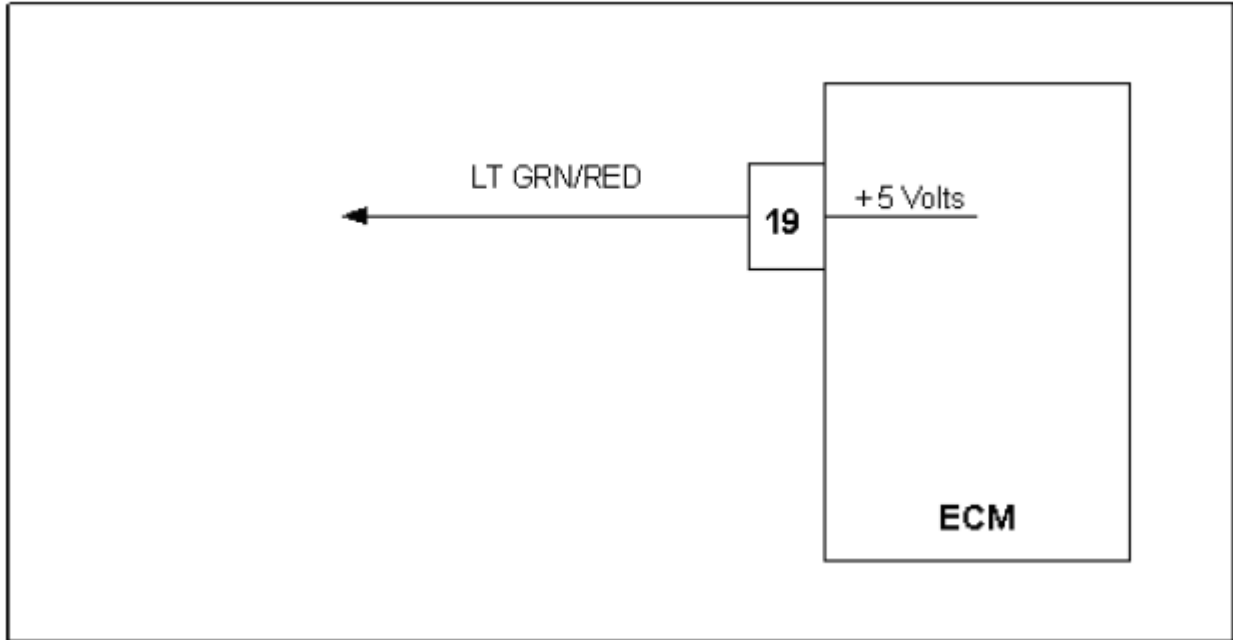

Conditions for Setting the DTC

- Check Condition: Engine cranking or running
- Fault Condition: 5 volt reference higher than 5.40 volts
- MIL: ON during active fault
- Adaptive: Disabled during active fault

Circuit Description

The External 5 volt supply powers many of the sensors and other components in the fuel system. The accuracy of the 5 volt supply is very important to the accuracy of the powered sensors and fuel control by the ECM. The ECM is able to determine if they are overloaded, shorted, or otherwise out of specification by monitoring the 5volt supply. This fault will set if the 5 volt reference is greater than 5.40 volts anytime the engine is cranking or running. Adaptive Learn will be disabled during this fault.

DTC 643 - External 5 Volt 1 Reference High

| Step | Action | Value(s) | Yes | No |
|------|--|--|----------------|--------------------------------|
| 1 | Did you perform the On-Board (OBD) System Check? | - | Go to Step (2) | Go to OBD System Check Section |
| 2 | Key ON, Engine Running System Mode = "Running" | Does DTC display DTC 643? | Go to Step (3) | Go to Step (4) |
| 3 | - | Using DST, is 5Vext1 FB (VE5a_FB_r aw) * 11/10 < 0.10 VDC? | Go to Step (5) | Go to Step (6) |
| 4 | Intermittent problem | | | |
| 5 | Wire connected to terminal # 19 at the ECM is partially or completely shorted to power (Vbat, Vsw, Vrelay, etc>) | | | |
| 6 | Poor ECM ground Faulty ECM | | | |

DTC 685 - Relay Coil Open

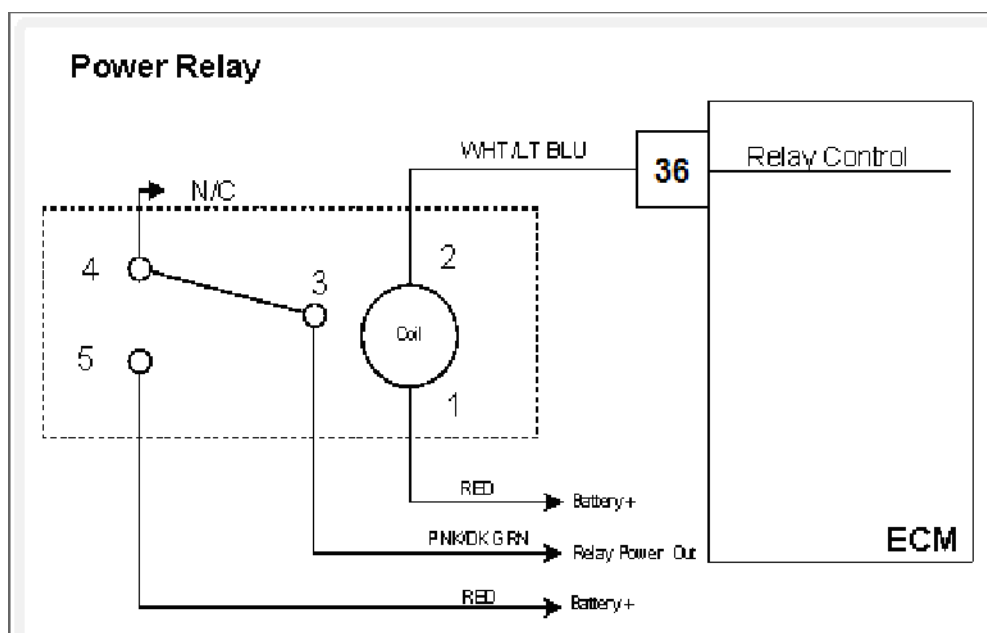

Conditions for Setting the DTC

- Check Condition: Key ON
- Fault Condition: Relay coil open

Circuit Description

The power relay switches power out to various sensors, actuators, and solenoids in the fuel system. This fault will set if the ECM detects an open circuit on the relay control output.

Diagnostic Aid

Relay coil resistance changes with temperature. The following diagnostic charts have steps to measure relay coil resistance values. When checking the resistance values be sure the relay is at a reasonable temperature, between +20- and +100-degrees F.

DTC 685 - Relay Coil Open

| Step | Action | Value(s) | Yes | No |
|------|--|---|----------------|--------------------------------|
| 1 | Did you perform the On-Board (OBD) System Check? | - | Go to Step (2) | Go to OBD System Check Section |
| 2 | Key ON, Engine Cranking System Mode = "Cranking" Verify that DTC 685 is active | | | |
| 3 | Remove Relay from fuse block/relay module Using a DMM, measure the voltage potential from the relay output to ground while the engine is trying to crank | Is voltage >80% of Vbat? | Go to Step (4) | Go to Step (5) |
| 4 | Key Off Connect test lamp to Vbat and Relay output Key On, Engine Off System Mode="Stopped" External power Test Mode="All On" | Does test lamp stay lit? | Go to Step (6) | Go to Step (7) |
| 5 | Faulty Relay | | | |
| 6 | Faulty Relay Faulty Relay connection/wiring | | | |
| 7 | Disconnect wire harness header from ECM Carefully remove yellow lock from header at device output terminal CAREFULLY check resistance between Relay output at ECM header and at relay. NOTE: DO NOT INSERT probe or object into terminals as this will cause the terminal to spread and may no longer make contact with ECM pins. Spread pins will void warranty! Probe on the side of terminal. | Does DMM indicate a resistance <5.0 ohms? | Go to Step (8) | Go to Step (9) |
| 8 | Faulty ECM | | | |
| 9 | Faulty harness (open-circuit) | | | |

DTC 686 - Relay Control Ground Short

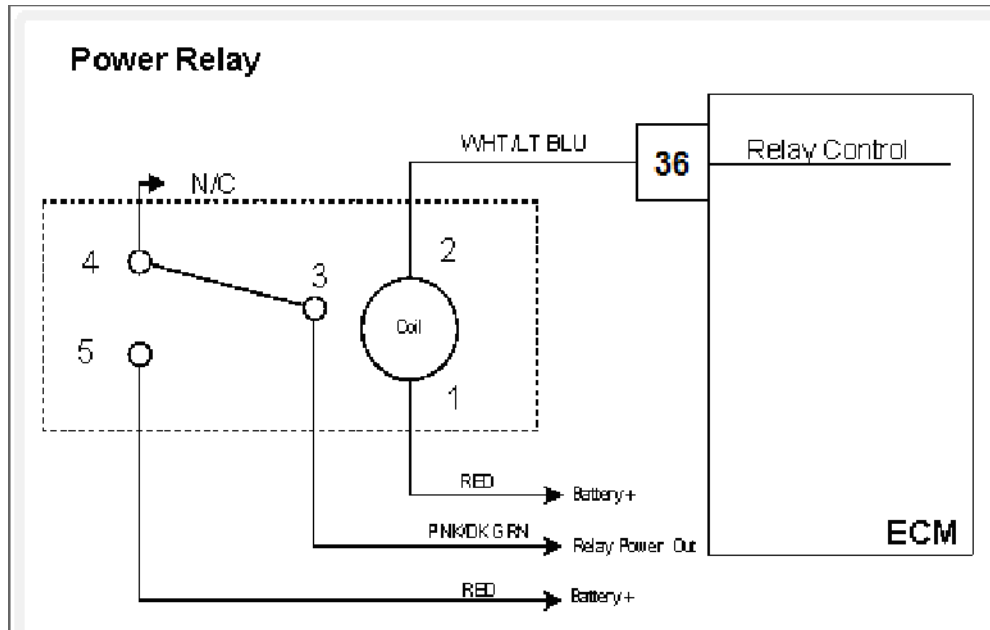

Conditions for Setting the DTC

- Check Condition: Key ON
- Fault Condition: Relay control shorted to ground

Circuit Description

The power relay switches power out to various sensors, actuators and solenoids in the fuel system. This fault will set if the ECM detects a short to ground on the relay control output.

Diagnostic Aid

Relay coil resistance changes with temperature. The following diagnostic charts have steps to measure relay coil resistance values. When checking the resistance values be sure the relay is at a reasonable temperature, between +20- and +100-degrees F.

DTC 686 - Relay Control Ground Short

| Step | Action | Value(s) | Yes | No |
|------|---|-----------------------------|----------------|--------------------------------|
| 1 | Did you perform the On-Board (OBD) System Check? | - | Go to Step (2) | Go to OBD System Check Section |
| 2 | Key ON, Engine Off System Mode = "Stopped" If "Stopped Check" is enabled, verify the DTYC 686 is active | | | |
| 3 | Remove Relay from fuse block/relay module | Is DTC 686 active? | Go to Step (4) | Go to Step (5) |
| 4 | Key On, Engine Off System Mode="Stopped" Using a DMM, measure the voltage potential from the relay output to ground | Is the resistance <10 ohms? | Go to Step (8) | Go to Step (7) |
| 5 | External Power Test Mode="All On" Using a DMM, measure the voltage potential from the relay output to ground | Is voltage >80% of Vbat? | Go to Step (4) | Go to Step (6) |
| 6 | Faulty Relay | | | |
| 7 | Faulty Relay | | | |
| 8 | Key Off Disconnect harness from ECM Using a DMM, measure the resistance from the relay output to ground | Is the resistance <10 ohms? | Go to Step (9) | Go to Step (10) |
| 9 | Faulty harness (open-circuit) | | | |
| 10 | Faulty ECM | | | |

DTC 687 - Relay Coil Short to Power

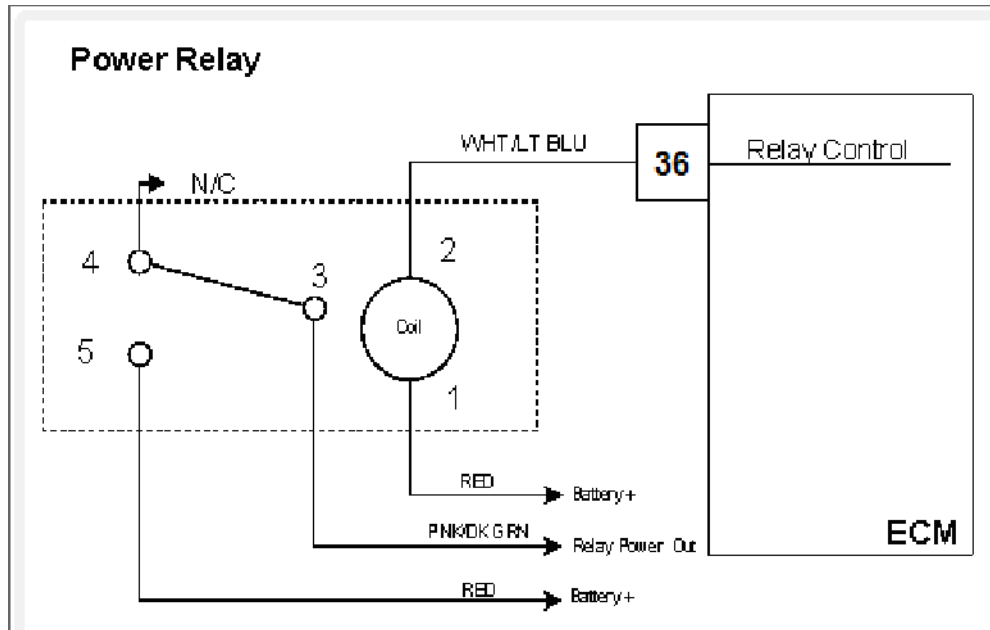

Conditions for Setting the DTC

- Check Condition: Key ON
- Fault Condition: Relay coil shorted to power

Circuit Description

The power relay switches power out to various sensors, actuators, and solenoids in the fuel system. This fault will set if the ECM detects a short circuit to power on the relay control output.

Diagnostic Aid

Relay coil resistance changes with temperature. The following diagnostic charts have steps to measure relay coil resistance values. When checking the resistance values be sure the relay is at a reasonable temperature, between +20- and +100-degrees F.

DTC 687 - Relay Coil Short to Power

| Step | Action | Value(s) | Yes | No |
|------|---|-----------------------------|----------------|--------------------------------|
| 1 | Did you perform the On-Board (OBD) System Check? | - | Go to Step (2) | Go to OBD System Check Section |
| 2 | Key ON, Engine Off System Mode = "Stopped" If "Stopped Check" is enabled, verify the DTYC 687 is active | | | |
| 3 | Remove Relay from fuse block/relay module | Is DTC 687 active? | Go to Step (4) | Go to Step (5) |
| 4 | Key On, Engine Off System Mode="Stopped" Using a DMM, measure the voltage potential from the relay output to ground | Is the resistance <10 ohms? | Go to Step (8) | Go to Step (7) |
| 5 | External Power Test Mode="All On" Using a DMM, measure the voltage potential from the relay output to ground | Is voltage >80% of Vbat? | Go to Step (4) | Go to Step (6) |
| 6 | Faulty Relay | | | |
| 7 | Faulty Relay | | | |
| 8 | Key Off Disconnect harness from ECM Using a DMM, measure the resistance from the relay output to Vbat | Is the resistance <10 ohms? | Go to Step (9) | Go to Step (10) |
| 9 | Faulty harness (ground short) | | | |
| 10 | Faulty ECM | | | |

DTC 726 - Max Govern Speed Override

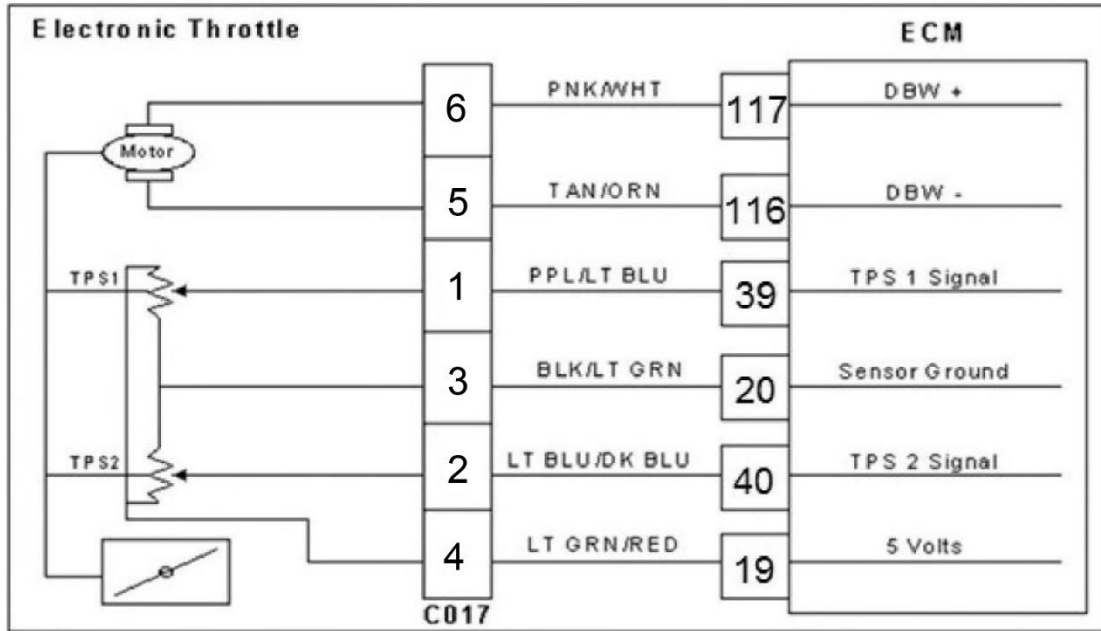

Conditions for Setting the DTC

- Check Condition: Engine Running
- Fault Condition: Engine rpm greater than 2,250 rpm
- Fault condition active for 2 or more seconds
- MIL: ON during active fault

Circuit description

This fault will set anytime the engine rpm exceeds 2,250 rpm for longer than 2 seconds. The MIL command is ON during this active fault.

Diagnostic Aid

Check for other stored DTC codes before using the following DTC chart for this code set. Always diagnose and repair any existing codes starting with the lowest numerical code first.

DTC 726 - Max Govern Speed Override

| Step | Action | Value(s) | Yes | No |
|------|---|----------|-----------------|--------------------------------|
| 1 | Did you perform the On-Board (OBD) System Check? | - | Go to Step (2) | Go to OBD System Check Section |
| 2 | Key ON, Engine OFF DST connected. Are any other DTC codes present with DTC 219? | | Go to Step (3). | Go to Step (4) |
| 3 | Diagnose and repair any other DTC codes stored before proceeding with this chart. Have any other DTC codes been diagnosed and repaired? | | Go to Step (4) | - |
| 4 | Check the service part number on the ECM to ensure the correct calibration is in use Is the Service Part Number Correct? | | Go to Step (6) | Go to Step 5 |
| 5 | Replace ECM with correct service part number Is the replacement complete? | | Go to Step (9) | - |
| 6 | Check the mechanical operation of the throttle Is the mechanical operation of the throttle, OK? | | Go to Step (8) | Go to Step (7) |
| 7 | Correct mechanical operation of the throttle. Refer to Engine & Component section. Has the mechanical operation of the throttle been corrected? | | Go to Step (9) | - |
| 8 | Check engine for large manifold vacuum leaks. Refer to Symptom Diagnostic section. Did you find and correct the vacuum leak? | | Go to Step (9) | Go to OBD System Check Section |
| 9 | Remove all test equipment except the DST. Connect any disconnected components, fuses, etc. Using the DST clear DTC information from the ECM. Turn the ignition OFF and wait 30 seconds. Start the engine and operate the vehicle to full operating temperature. Observe the MIL Observe engine performance and drivability After operating the engine within the test parameters of DTC-219 check for any stored codes. Does the engine operate normally with no stored codes? | | System OK | Go to OBD System Check |

DTC 1111 - Fuel Rev Limit

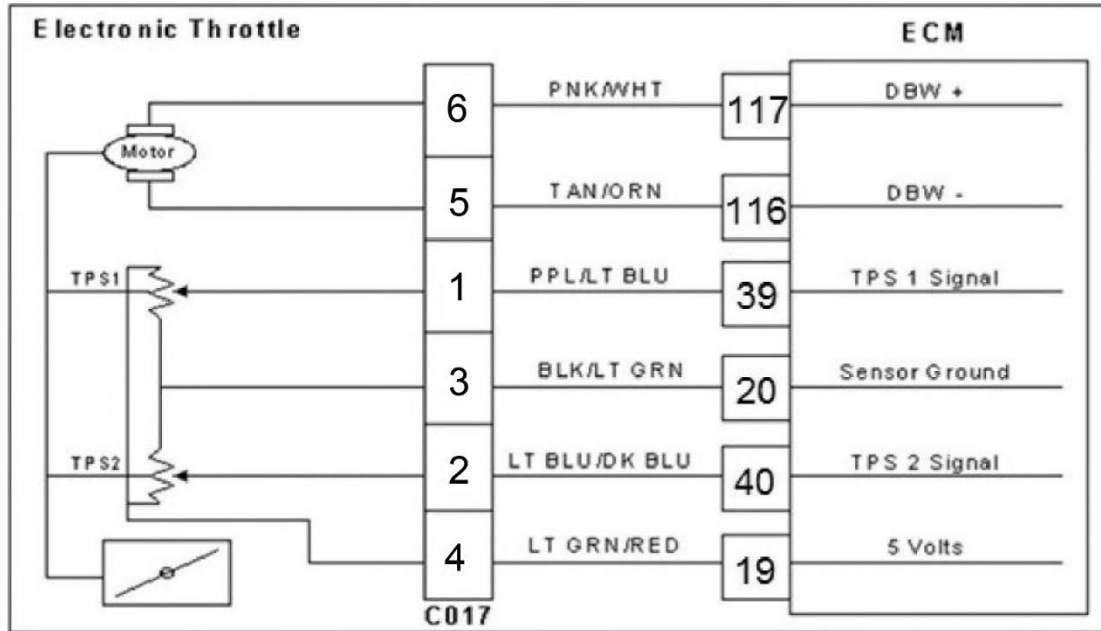

Conditions for Setting the DTC

- Check Condition: Engine Running
- Fault Condition: Engine rpm greater than 2300rpm set limit
- MIL: ON during active fault

Circuit Description

This fault will set anytime the engine rpm exceeds the specified speed settings in the calibration. This is generally set at 2300 rpm. The MIL command is ON during this active fault.

Diagnostic Aid

Always check for other stored DTC codes before using the following DTC chart for this code set. Repair any existing codes starting with the lowest numerical code first.

DTC 1111 - Fuel Rev Limit

| Step | Action | Value(s) | Yes | No |
|------|--|----------|----------------|--------------------------------|
| 1 | Did you perform the On-Board (OBD) System Check? | - | Go to Step (2) | Go to OBD System Check Section |
| 2 | Key ON, Engine OFF DST in Active Fault Mode Are any other DTC codes present with DTC 1111? | | Go to Step (3) | Go to Step (4) |
| 3 | Diagnose and repair any other DTC codes before proceeding with this chart. Have any other DTC codes been diagnosed and repaired? | | Go to Step (4) | - |
| 4 | Check the service part number on the ECM to ensure correct calibration is in use Is the service part number correct? | | Go to Step (6) | Go to Step 5 |
| 5 | Replace ECM with the correct service part number Is the replacement complete? | | Go to Step (9) | - |
| 6 | Check the mechanical operation of the throttle Is the mechanical operation of the throttle OK? | | Go to Step (8) | Go to Step (7) |
| 7 | Correct mechanical operation of the throttle. Refer to Engine & Component section Has the mechanical operation of the throttle been corrected? | | Go to Step (9) | - |
| 8 | Check engine for large manifold vacuum leaks. Refer to Fuel Systems symptom diagnostics Did you find and correct the vacuum leaks? | | Go to Step (9) | Go to OBD System Check Section |
| 9 | Remove all test equipment except the DST. Connect any disconnected components, fuses, etc. Using the DST clear DTC information from the ECM. Turn the ignition OFF and wait 30 seconds. Start the engine and operate the vehicle to full operating temperature. Observe the MIL Observe engine performance and drivability After operating the engine within the test parameters of DTC-1111 check for any stored codes. Does the engine operate normally with no stored codes? | | System OK | Go to OBD System Check |

DTC 1112 - Spark Rev Limit

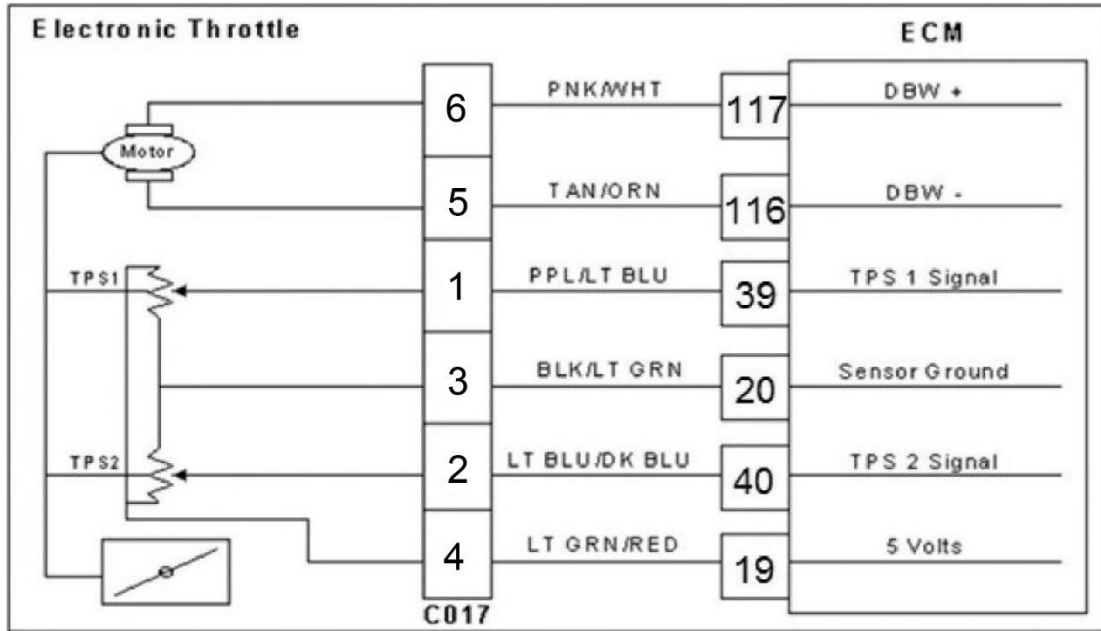

Conditions for Setting the DTC

- Check Condition: Engine running
- Fault Condition: Engine rpm greater than 2325 rpm set limit
- MIL: ON during active fault
- Engine Shut Down

Circuit description

This fault will set anytime the engine rpm exceeds the specified speed settings installed in the calibration. This is set at 2325 rpm. The MIL command is ON during this active fault and the engine will shut down.

Diagnostic Aid

Always check for other stored DTC codes before using the following DTC chart for this code set. Repair any existing codes starting with the lowest numerical code first.

DTC 1112 - Spark Rev Limit

| Step | Action | Value(s) | Yes | No |
|------|--|----------|----------------|--------------------------------|
| 1 | Did you perform the On-Board (OBD) System Check? | - | Go to Step (2) | Go to OBD System Check Section |
| 2 | Key ON, Engine OFF DST connected Are any other DTC codes present with DTC 1112? | | Go to Step (3) | Go to Step (4) |
| 3 | Diagnose any other DTC codes before proceeding with this chart. Have any other DTC codes been diagnosed and repaired? | | Go to Step (4) | - |
| 4 | Check the service part number on the ECM to ensure correct calibration is in use Is the service part number correct? | | Go to Step (6) | Go to Step (5) |
| 5 | Replace ECM with correct service part number Is the replacement complete? | | Go to Step (9) | - |
| 6 | Check the mechanical operation of the throttle Is the mechanical operation of the throttle OK? | | Go to Step (8) | Go to Step (7) |
| 7 | Correct mechanical operation of the throttle. Refer to Engine & Component section Has the mechanical operation of the throttle been corrected? | | Go to Step (9) | - |
| 8 | Check engine for large manifold vacuum leaks. Refer to Fuel Systems section Symptom Diagnostics Did you find and correct the vacuum leak? | | Go to Step (9) | Go to OBD System Check Section |
| 9 | Remove all test equipment except the DST. Connect any disconnected components, fuses, etc. Using the DST clear DTC information from the ECM. Turn the ignition OFF and wait 30 seconds. Start the engine and operate the vehicle to full operating temperature Observe the MIL Observe engine performance and drivability After operating the engine within the test parameters of DTC-1112 check for any stored codes. Does the engine operate normally with no stored codes? | | System OK | Go to OBD System Check |

DTC 1151 - Closed Loop High LPG

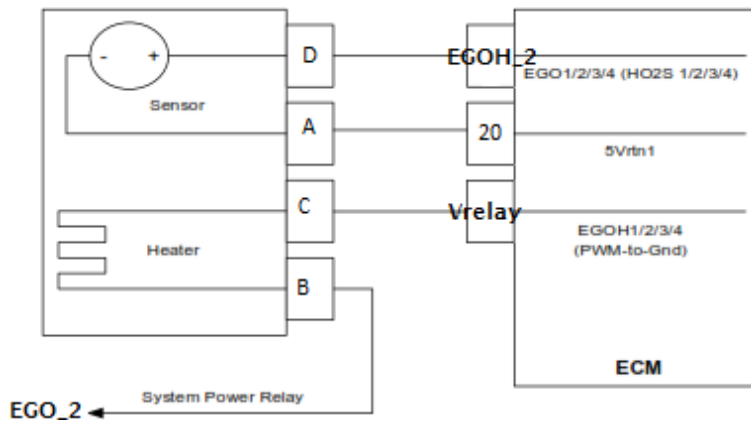

Conditions for Setting the DTC

- Check Condition-Engine running
- Fault Condition-Closed Loop multiplier out of range (greater than 35%) while running on propane
- MIL-ON

Circuit description

The UEGO sensor is used to determine if the fuel flow to the engine is correct by measuring the oxygen content in the exhaust gas. The ECM uses this information to correct the fuel flow with the Closed Loop multiplier and the adaptive multiplier. This fault sets if the Closed Loop multiplier exceeds the limits of normal operation and cannot correctly modify the fuel flow within its limits.

Diagnostic Aid

Vacuum Leaks - Large vacuum leaks and crankcase leaks can cause a lean exhaust condition at especially at light load.

Fuel Mixer - System can be lean due to faulty EPR (Electronic Pressure Regulator) or faulty fuel mixer. **Fuel**

Pressure - System will be lean if fuel pressure is too low. Ensure fuel pressure is not too low and that gaseous fuel control actuator/regulator has proper fuel pressure under all operating conditions. Ensure proper coolant flow to LP vaporizer.

Exhaust Leaks - If there is an exhaust leak, outside air can be pulled into the exhaust and past the O₂ sensor causing a false lean condition.

Misfire - A misfiring cylinder will pass oxygen through rather than burning it. The sensor will interpret this oxygen as a lean condition and enrichen the fuel mixture.

Fuel Quality - A drastic variation in fuel quality may cause the system to be lean.

Ground Problem - ECM and engine must be grounded to the battery with very little resistance allowing for proper current flow. Faulty grounds can cause current supply issues resulting in many undesired problems.

Oxygen Sensor Wire - Sensor may be mispositioned contacting the exhaust. Check for short to ground between harness and sensor sense signal.

If all tests are OK, replace the O₂ sensors with known good parts and retest.

DTC 1152 - Closed Loop Multiplier Low LPG

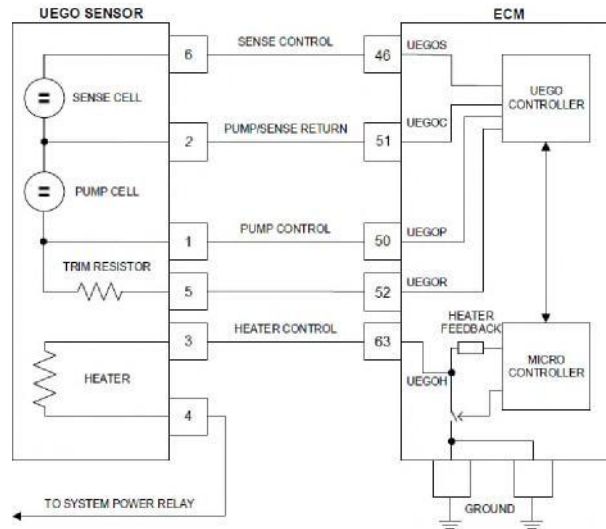

Conditions for Setting the DTC

- Functional Fault: Closed Loop multiplier out of range (at limit of -35%) while running on propane
- MIL ON

Circuit Description

The UEGO sensor is used to determine if the fuel flow to the engine is correct by measuring the oxygen content in the exhaust gas. The ECM uses this information to correct the fuel flow with the Closed Loop multiplier and the adaptive multiplier. This fault sets if the Closed Loop multiplier exceeds the limits of normal operation. When the multiplier cannot correctly modify the fuel flow within its limits, it is limited at -35%.

Diagnostic Aid

Fuel System High secondary fuel pressure will cause the system to run rich. A worn fuel mixer or faulty EPR (Electronic Pressure Regulator) may also cause the system to run rich.

Fuel Quality A drastic variation in fuel quality (very high butane content) may cause the fuel system to run rich. Be sure that the specified HD-5 or HD-10 motor fuel grade LPG is used.

Air Filter A plugged, damaged or modified air filter may cause the system to run rich.

Note:

- If one bank shows high adaptive and the other is low, the O2 sensor leads are crossed. Trace those wires back to their ECM's are correct accordingly.

DTC 1153 - Closed Loop Multiplier High NG

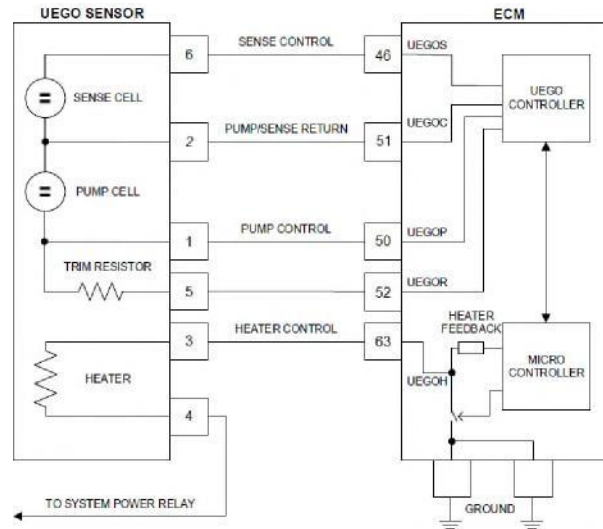

Conditions for Setting the DTC

- Functional Fault: Closed Loop multiplier out of range (greater than 35%) while running on natural gas
- MIL: ON

Circuit Description

The UEGO sensor is used to determine if the fuel flow to the engine is correct by measuring the oxygen content in the exhaust gas. The ECM uses this information to correct the fuel flow with the Closed Loop multiplier and the adaptive multiplier. This fault sets if the Closed Loop multiplier exceeds the limits of normal operation and cannot correctly modify the fuel flow within its limits.

Diagnostic Aid

Vacuum Leaks Large vacuum leaks and crankcase leaks can cause a lean exhaust condition, especially at light load.

Fuel Mixer System can be lean due to a faulty EPR (Electronic Pressure Regulator) or faulty fuel mixer.

Fuel Pressure System will be lean if fuel pressure is too low. Ensure fuel pressure is not too low and that gaseous fuel control actuator/regulator has proper fuel pressure under all operating conditions.

Exhaust Leaks If there is an exhaust leak, outside air can be pulled into the exhaust and past the O₂ sensor causing a false lean condition.

Misfire A misfiring cylinder will pass oxygen through rather than burning it. The sensor will interpret this oxygen as a lean condition and enrichen the fuel mixture.

Fuel Quality A drastic variation in fuel quality may cause the system to be lean.

Ground Problem ECM and engine must be grounded to the battery with very little resistance allowing for proper current flow. Faulty grounds can cause current supply issues resulting in many undesired problems. **Oxygen Sensor Wire** Sensor may be mispositioned contacting the exhaust. Check for short to ground between harness and sensor sense signal.

If all tests are OK, replace the O₂ sensors with known good parts and retest.

Note:

- If one bank shows high adaptive and the other is low, the O2 sensor leads are crossed. Trace those wires back to their ECM's are correct accordingly.

DTC 1154 - Closed Loop Multiplier Low NG

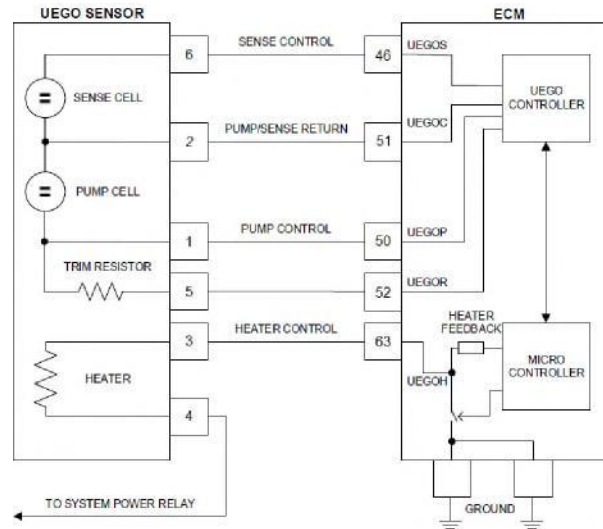

Conditions for Setting the DTC

- Functional Fault: Closed Loop multiplier out of range (at limit of -35%) while running on natural gas
- MIL: ON

Circuit Description

The UEGO sensor is used to determine if the fuel flow to the engine is correct by measuring the oxygen content in the exhaust gas. The ECM uses this information to correct the fuel flow with the Closed Loop multiplier and the adaptive multiplier. This fault sets if the Closed Loop multiplier exceeds the limits of normal operation. When the multiplier cannot correctly modify the fuel flow within its limits, it is limited at -35%.

Diagnostic Aid

Fuel System High secondary fuel pressure will cause the system to run rich. A worn fuel mixer, faulty EPR (Electronic Pressure Regulator) may also cause the system to run rich.

Fuel Quality A drastic variation in fuel quality (high content of ethane and heavier hydrocarbons) may cause the fuel system to run rich. If running on wellhead gas, obtain a current gas analysis report for your fuel source. Wells can change over time and the gas supply may be different than when a sample was originally taken. Air Filter A plugged, damaged or modified air filter may cause the system to run rich.

Note:

- If one bank shows high adaptive and the other is low, the O2 sensor leads are crossed. Trace those wires back to their ECM's are correct accordingly.

DTC 1161 - Adaptive Learn High LPG

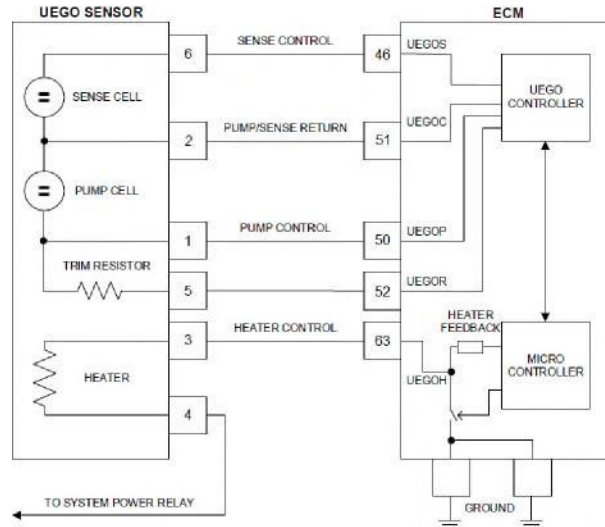

Conditions for Setting the DTC

- Check Condition: Engine Running
- Fault Condition: Adaptive multiplier out of range greater than 30% while running on propane
- MIL: ON

Circuit Description

The UEGO sensor is used to determine if the fuel flow to the engine is correct by measuring the oxygen content in the exhaust gas. The ECM uses this information to correct the fuel flow with the Closed Loop multiplier and Adaptive multiplier. This fault will set if the adaptive multiplier exceeds the limits of normal operation. Always run the fuel system diagnostic checks before using the following diagnostic chat.

Diagnostic Aid

Oxygen Sensor Wire - Oxygen sensor wires may be mis-routed and contacting the exhaust manifold, pipes, or other hot parts causing damage.

Vacuum Leaks - Large vacuum leaks and crankcase leaks can cause a lean exhaust condition at especially at light load.

Fuel Mixer - System can be lean due to faulty EPR (Electronic Pressure Regulator) or faulty fuel mixer.

Fuel Pressure - Low fuel pressure, faulty fuel regulator or contaminated fuel filter can cause fuel the system to run lean

Exhaust Leaks - If there is an exhaust leak, outside air can be pulled into the exhaust and past the O2 sensor causing a false lean condition.

Fuel Quality - Contaminated or spoiled fuel can cause the fuel system to be lean.

Ground Problem - ECM grounds must be clean, tight and in the proper location.

Note:

- If one bank shows high adaptive and the other is low, the O2 sensor leads are crossed. Trace those wires back to their ECM's are correct accordingly.

DTC 1162 - Adaptive Learn Low LPG

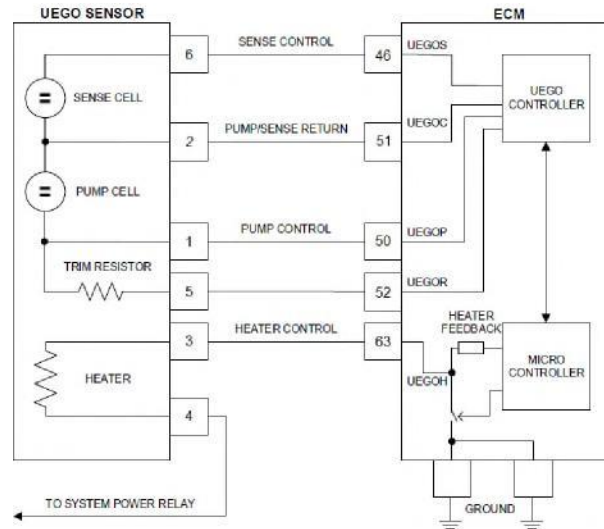

Conditions for Setting the DTC

- Check Condition: Engine running
- Fault Condition: Adaptive multiplier out of range greater than -30% while running on propane
- MIL: ON

Circuit Description

The UEGO sensor is used to determine if the fuel flow to the engine is correct by measuring the oxygen content in the exhaust gas. The ECM uses this information to correct the fuel flow with the Closed Loop multiplier and Adaptive multiplier. This fault will set if the adaptive multiplier exceeds the limits of normal operation. Always run the fuel system diagnostics before using the following diagnostic chart.

Diagnostic Aid

Fuel System - High secondary fuel pressure will cause the system to run rich. A worn fuel mixer, faulty EPR (Electronic Pressure Regulator) may also cause the system to run rich.

Fuel Quality - A drastic variation in fuel quality (very high butane content) may cause the fuel system to run rich. Be sure that the specified HD-5 or HD-10 motor fuel grade propane is used.

Air Filter - A plugged, damaged or modified air filter may cause the system to run rich.

Note:

- If one bank shows high adaptive and the other is low, the O2 sensor leads are crossed. Trace those wires back to their ECM's are correct accordingly.

DTC 1163 - Adaptive Learn High NG

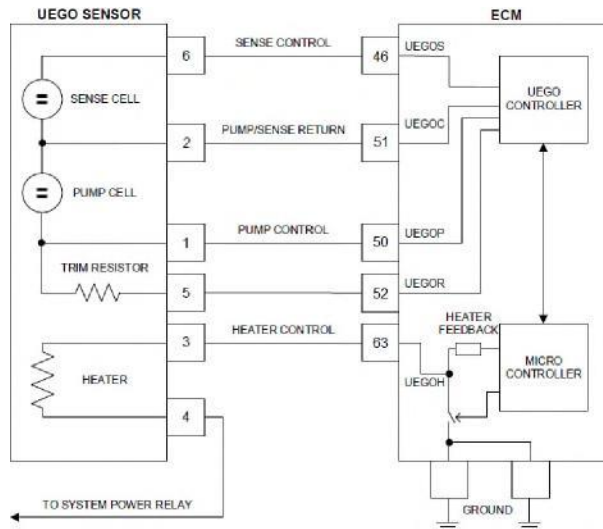

Conditions for Setting the DTC

- Check Condition: Engine Running
- Fault Condition: Adaptive multiplier out of range greater than 30% while running on natural gas
- MIL: ON

Circuit Description

The UEGO sensor is used to determine if the fuel flow to the engine is correct by measuring the oxygen content in the exhaust gas. The ECM uses this information to correct the fuel flow with the Closed Loop multiplier and Adaptive multiplier. This fault will set if the adaptive multiplier exceeds the limits of normal operation. Always run the fuel system diagnostic checks before using the following diagnostic chat.

Diagnostic Aid

Oxygen Sensor Wire - Heated Oxygen sensor wires may be mis-routed and contacting the exhaust manifold.

Vacuum Leaks Large - vacuum leaks and crankcase leaks can cause a lean exhaust condition at especially at light load.

Fuel Mixer - System can be lean due to faulty EPR (Electronic Pressure Regulator) or faulty fuel mixer.

Fuel Pressure - Low fuel pressure, faulty fuel regulator or contaminated fuel filter can cause fuel the system to run lean

Exhaust Leaks - If there is an exhaust leak, outside air can be pulled into the exhaust and past the O2 sensor causing a false lean condition.

Fuel Quality - Contaminated or spoiled fuel can cause the fuel system to be lean.

Ground Problem - ECM grounds must be clean, tight and in the proper location.

Note:

- If one bank shows high adaptive and the other is low, the O2 sensor leads are crossed. Trace those wires back to their ECM's are correct accordingly.

DTC 1164 - Adaptive Learn Low NG

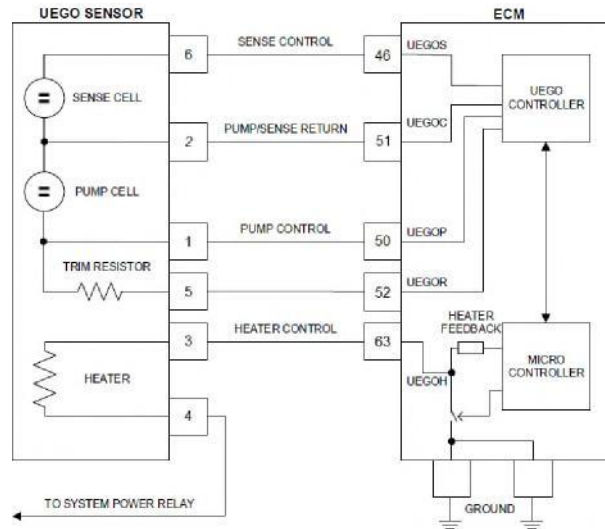

Conditions for Setting the DTC

- Check Condition: Engine running
- Fault Condition: Adaptive multiplier out of range greater than -30% while running on natural gas
- MIL: ON

Circuit Description

The UEGO sensor is used to determine if the fuel flow to the engine is correct by measuring the oxygen content in the exhaust gas. The ECM uses this information to correct the fuel flow with the Closed Loop multiplier and Adaptive multiplier. This fault will set if the adaptive multiplier exceeds the limits of normal operation. Always run the fuel system diagnostics before using the following diagnostic chart.

Diagnostic Aid

Fuel System - High secondary fuel pressure will cause the system to run rich. A worn fuel mixer, faulty EPR (Electronic Pressure Regulator) may also cause the system to run rich.

Fuel Quality - A drastic variation in fuel quality (very high butane content) may cause the fuel system to run rich. Be sure that the specified HD-5 or HD-10 fuel grade propane is used.

Air Filter - A plugged, damaged or modified air filter may cause the system to run rich.

Note:

- If one bank shows high adaptive and the other is low, the O2 sensor leads are crossed. Trace those wires back to their ECM's are correct accordingly.

DTC 1271 - EPR Secondary Regulation Pressure Higher Than Expected

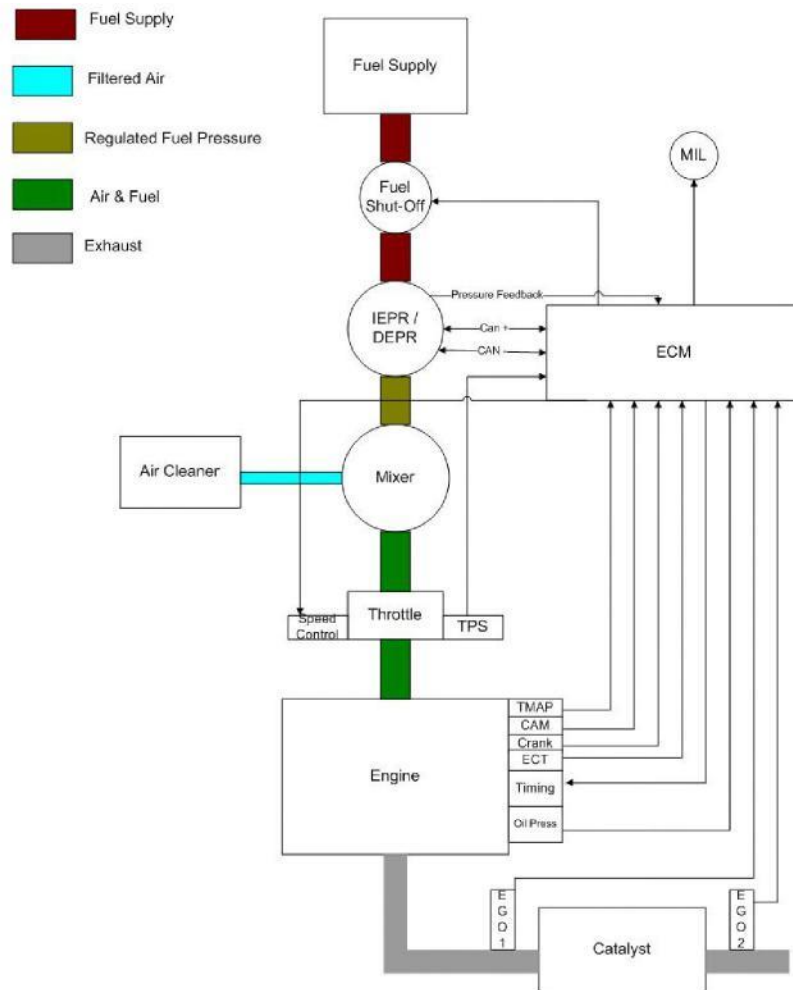

Conditions for Setting the DTC

- Check condition: Engine running or cranking
- MIL: ON during active fault
- Fault condition: EPR or CFV (actual-command) pressure greater than 10.00 PSI
- Engine shutdown will occur

Circuit Description

The EPR (Electronic Pressure Regulator) unit measures and controls the amount of fuel that is able to pass to the fuel mixer. This code will set in the event the actual pressure is 10.00 psi inches water pressure higher than the actual commanded pressure. MIL command is ON during this fault. The engine will shut down if this fault occurs.

Diagnostic Aid

Always run the fuel system diagnostic pressure check before proceeding with the following diagnostic chart. **High fuel pressure into the EPR is the most common cause of this fault.**

DTC 1271 - EPR Secondary Regulation Pressure Higher Than Expected

| Step | Action | Value(s) | Yes | No |
|------|---|----------|--|---|
| 1 | Did you perform the On-Board (OBD) System Check? | - | Go to Step (2) | Go to OBD System Check Section |
| 2 | Did you run the fuel pressure diagnostic test in the fuel system diagnostic section with no problems found? | | Go to Step (4) | Go to Step (3) |
| 3 | Run the EPR pressure test in the fuel system diagnostic section Did the EPR pass the fuel pressure test specifications? | | Go to Step (4) | Follow the EPR service recommendations from the fuel pressure test chart. |
| 4 | Inspect the EPR electrical connector pins C018 for damage, corrosion, or contamination. Did you find a problem? | | Repair the circuit as necessary. Refer to wire harness repair section. | Go to Step (5) |
| 5 | Replace or repair the EPR Is the replacement complete? | | Go to Step (6) | - |
| 6 | Remove all test equipment except the DST. Connect any disconnected components, fuses, etc. Using the DST clear DTC information from the ECM. Turn the ignition OFF and wait 30 seconds. Start the engine and operate the vehicle to full operating temperature. Observe the MIL Observe engine performance and drivability After operating the engine within the test parameters of DTC1171 check for any stored codes. Does the engine operate normally with no stored codes? | | System OK | Go to OBD System Check |

DTC 1272 - EPR Secondary Regulation Pressure Lower Than Expected

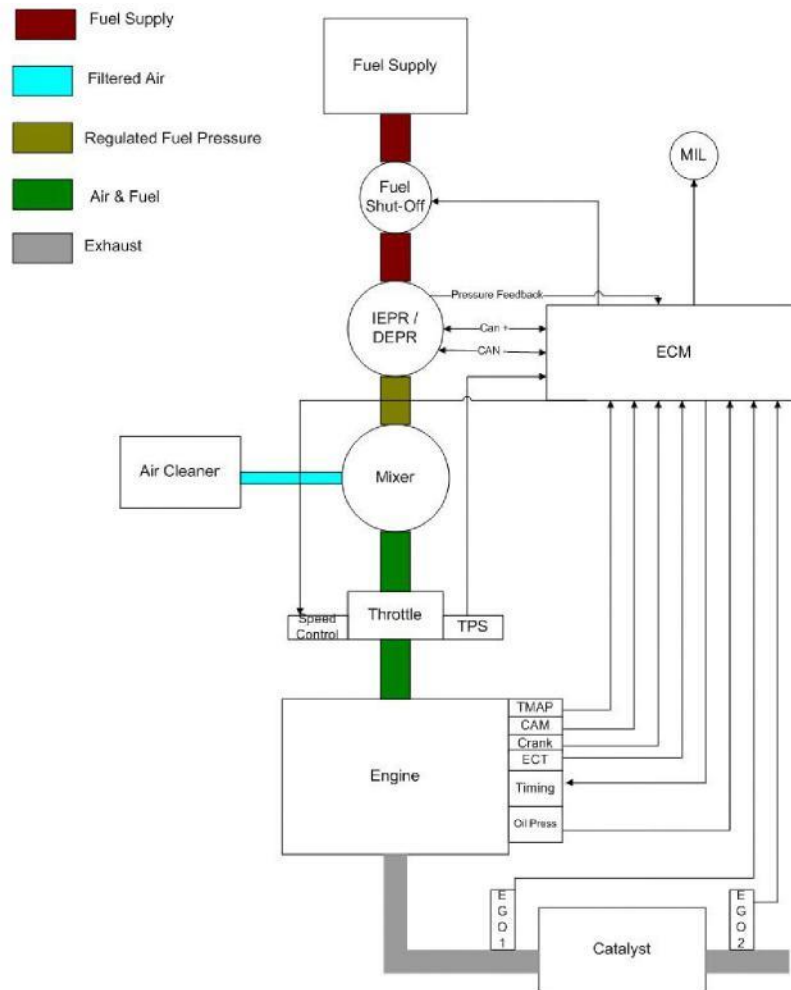

Conditions for Setting the DTC

- Check condition: Engine running or cranking
- MIL: ON during active fault
- Fault condition: EPR or CFV (actual-command) pressure greater than 10.00 PSI
- Engine shutdown will occur

Circuit Description

The EPR (Electronic Pressure Regulator) unit measures and controls the amount of fuel that is able to pass to the fuel mixer. This code will set in the event the actual pressure is -10.00 inches water pressure lower than the actual commanded pressure. MIL command is ON during this fault. Engine will shut down if this fault occurs.

Diagnostic Aid

Always run the fuel system diagnostic pressure check before proceeding with the following diagnostic chart. **High fuel pressure into the EPR is the most common cause of this fault.**

DTC 1272 - EPR Secondary Regulation Pressure Lower Than Expected

| Step | Action | Value(s) | Yes | No |
|------|---|----------|--|---|
| 1 | Did you perform the On-Board (OBD) System Check? | - | Go to Step (2) | Go to OBD System Check Section |
| 2 | Did you run the fuel pressure diagnostic test in the fuel system diagnostic section with no problems found? | | Go to Step (4) | Go to Step (3) |
| 3 | Run the EPR pressure test in the fuel system diagnostic section. Did the EPR pass the fuel pressure test specifications? | | Go to Step (4) | Follow the EPR service recommendations from the fuel pressure test chart. |
| 4 | Inspect the EPR electrical connector C018 for damage, corrosion, or contamination. Did you find a problem? | | Repair the circuit as necessary. Refer to wire harness repair section. | Go to Step (5) |
| 5 | Replace or repair the EPR Is the replacement complete? | | Go to Step (6) | - |
| 6 | Remove all test equipment except the DST. Connect any disconnected components, fuses, etc. Using the DST clear DTC information from the ECM. Turn the ignition OFF and wait 30 seconds. Start the engine and operate the vehicle to full operating temperature. Observe the MIL Observe engine performance and drivability After operating the engine within the test parameters of DTC1172 check for any stored codes. Does the engine operate normally with no stored codes? | | System OK | Go to OBD System Check |

DTC 1325 - Knock Retard at Limit

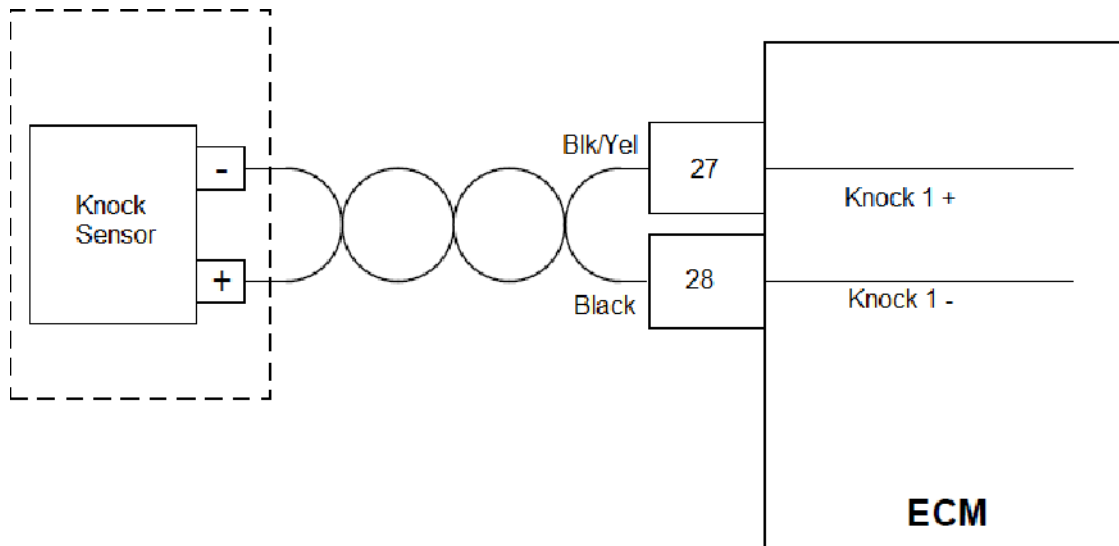

Conditions for Setting the DTC

- Check Condition: Key On, Engine Running
- Fault Condition: With RPM greater than 1200 and MAP load greater than 11 psia, knock retard is at 100% for 125 combustion cycles (1 cycle = 2 revs, 8.3 seconds at 1800 RPM, 10 seconds at 1500 RPM)
- MIL: ON during active fault
- Engine Shutdown

Fault Description

The knock sensor is used to detect detonation through mechanical vibration in the engine block and/or cylinder heads and provide feedback for the ignition system to retard spark timing to reduce knock intensity. In most applications the knock sensor is used to protect the engine from damage that can be caused from detonation or knock based on fixed spark advance. This fault sets if the signals from the knock sensors indicate severe engine knocking, triggering maximum knock retard for 125 combustion cycles (one cycle = two crank rotations). The MIL will light and the engine will shut down.

Diagnostic Aids

This fault occurs when the engine is actively knocking, and the shutdown is triggered to protect the engine from potentially catastrophic damage. Knock can be caused by a number of factors, including:

- Poor quality fuel
- Elevated intake air temperature
- Elevated coolant temperature
- Loads exceeding engine load limit
- Excessive exhaust backpressure

If running on wellhead gas, a gas analysis sample should be taken to check the makeup of the wellhead gas. Wellhead gas can vary greatly in quality, even from the same well over time. It is important to reduce the load when running on "hot" gas (gas containing a higher than usual concentration of ethane and larger hydrocarbons) in order to keep cylinder pressures down below the threshold where knock can occur. Contact your OEM for more information on running an engine on wellhead gas.

DTC 1325 - Knock Retard at Limit

Verify that the engine is running at the proper load for your application at all times. Make sure that any required derates* for elevation, ambient temperature, and gas quality are applied to the maximum load. Verify all loads to be certain there isn't a situation that can cause load to suddenly spike above the limit, e.g. motors starting simultaneously. Consider using VFDs (Variable Frequency Drivers) if there are cumulative inrush currents that could be overloading your engine.

Higher intake and coolant temperatures and excessive exhaust back pressure can lead to higher in-cylinder temperatures, which will contribute to the likelihood of knock.

- Make sure the engine is receiving intake air that is as cool as possible. Elevated intake air temperatures can be caused by exhaust leaks near the intake, blocked or closed intake louvers on an enclosure, or air circulating over hot engine components.
- The cooling system should also be checked. Clogged radiator/CAC cores, low coolant level, loose, slipping, or broken fan and/or water pump belts can all lead to elevated engine coolant temperatures.
- Check the exhaust system for proper flow. Make sure there are no obstructions in the piping, catalyts, or muffler (if equipped).

If the engine is thoroughly inspected and found to not be experiencing any knock, there are other factors that can sometimes cause the knock sensors to detect vibrations that the ECM will interpret as knock:

- Check the engine and all attached components for any loose nuts, bolts, or brackets that could be vibrating.
- Check to make sure there is nothing coming in contact with any of the knock sensors.
- Verify that the knock sensors are properly secured to the engine and the nut/bolt is correctly torqued:

q Nut: 18 lb/ft

q Bolt: 20 lb/ft

- Check the spark plugs, ignition coils, and coil boots on all cylinders to make sure the ignition system is performing properly and there is no misfire. Make sure spark plugs are the correct type as recommended by the manufacturer.
- Check and adjust engine valve lash as necessary. Loose valve lash can cause vibrations in the engine that is picked up by the knock sensors and could be interpreted by the ECM as knock.

*For information on derates consult PSI Heavy-Duty Technical Standard 56300003 - PSI HD Derate Specification.

DTC 1326 - Knock Retard Above Threshold

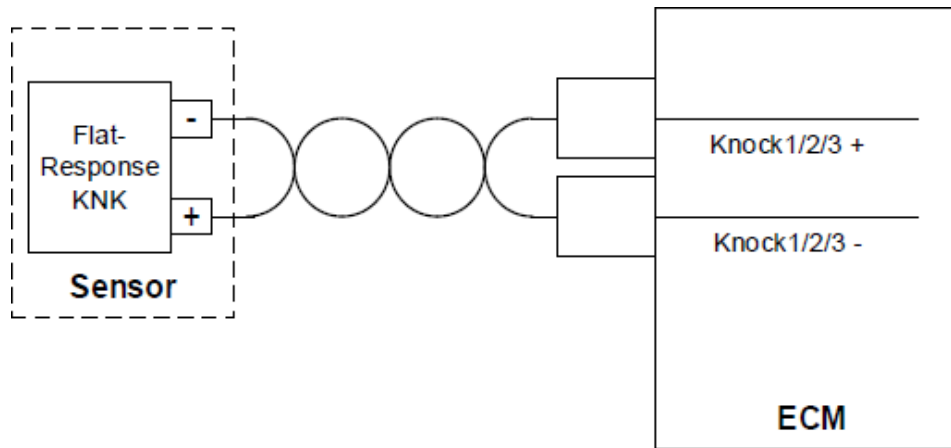

Conditions for Setting the DTC

- Check Condition: Key On, Engine Running / Stopped Checked
- Fault Condition: With RPM greater than 1000 and MAP load greater than 8 psia, and ECT >-40.0 deg F, and engine run time > 120.0 sec, and knock spark retard at percent of maximum 50%, and octane rating <=100%
- MIL: ON during active fault

Fault Description

The knock sensor is used to detect detonation through mechanical vibration in the engine block and/or cylinder heads and provide feedback for the ignition system to retard spark to reduce knock intensity. In most applications the knock sensor is used to protect the engine from damage that can be caused from detonation or knock based on fixed spark advance. In other applications, the knock sensor is used to optimize spark advance and “learn” between spark tables based on fuel quality.

This fault sets when the engine is retarding the ignition timing due to knock. If the amount of retard is above the percentage of the maximum retard (without consideration of ‘active knock’– see Knock Retard at Limit fault description) the fault will be set.

Diagnostic Aids:

- If other DTCs exist diagnose these first.
- Refer to the engine manufacturer’s service manual for additional information.

DTC 1330 - Intake Backfire Detected

Conditions for Setting the DTC

- Check Condition: Key On
- Fault Condition: Intake backfires ≥ 4 events
- MIL: ON
- Adaptive: Disabled during active fault

Fault description

The ECM detects IAT readings which may indicate an intake backfire. This may be caused by improper fuel-air mixtures, worn ignition components, improper valve lash settings, engine timing and possibly bad sensors.

The DTC is set to trigger an event based off of any change in IAT¹ greater than 25 deg F/sec greater than 20ms. Once an event is counted, it will be stored in a histogram visible on the "Service" page in 4G Display. The diagnostic is set around these event counts within a timeframe.

¹This is a calculated IATdt which is a filtered signal. You cannot directly relate this to IAT or rIAT in a bplt for 1:1 visual if it will trigger.

Diagnostic Aids

- Capture **ALL fault code history** in MASTER and SLAVE ECM's
- Download **ALL fault code flight data recorders** from MASTER and SLAVE ECM's
- Download **ALL fault snapshot** from MASTER and SLAVE ECM's
- Download **Backfire Histogram** from MASTER and SLAVE ECM's (located on Service page)
- **Inspect spark plugs for water ingress/corrosion** from the top side (coil side)
- **Ignition coil wire harness inspection** (closely looking at pin conditions)
- **Spark Plug Resistance Value²** = 3.5 to 7 kOhm (Acceptable resistance value)
- **Verify Crank Position Sensor gap²** --> Shim as needed

²M Series only

Below is a list of issues that may indicate a backfire event has occurred.

- Damaged or melted MAP sensor
- DTC 111 (IAT Higher than Expected 1)
- DTC 127 (IAT Higher than Expected 2)
- DTC 112 (IAT Voltage Low)

DTC 1330 - Intake Backfire Detected

EDIS ECI Target Communications _ □ ×

File Page Flash Comm Port Plot/Log Settings Help

EControls Service MIL ← → ↻ REC Error opening ECom module in HandleConnect, (error code 251)

| No | No | No | No | No | No |

Hour Last Commit | 0.000 | Hour Hst 1 | 0.000 | Hour Hst 2 | 0.000

Intake Backfire Monitoring

Intake backfire detection mode Disabled ▾

Intake backfire IATdt limit deg F/sec

Intake backfire MAP limit psia

Intake backfire latch time ms

Intake backfire unlatch time ms

IATdt deg F/sec

IATdt max (key cycle) deg F/sec

Intake Backfire Histogram (Lifetime)

| Speed (rpm) | MAP load (psia) | | | | |
|-------------|-----------------|-----|-----|-----|-----|
| | 0.0 | 0.0 | 0.0 | 0.0 | 0.0 |
| 0 | 0 | 0 | 0 | 0 | 0 |
| 0 | 0 | 0 | 0 | 0 | 0 |
| 0 | 0 | 0 | 0 | 0 | 0 |
| 0 | 0 | 0 | 0 | 0 | 0 |
| 0 | 0 | 0 | 0 | 0 | 0 |
| 0 | 0 | 0 | 0 | 0 | 0 |

Intake Backfire Occurrences

Total intake backfires (lifetime) occurrences

Intake Backfire Histogram (Recent)

| Speed (rpm) | MAP load (psia) | | | | |
|-------------|-----------------|-----|-----|-----|-----|
| | 0.0 | 0.0 | 0.0 | 0.0 | 0.0 |
| 0 | 0 | 0 | 0 | 0 | 0 |
| 0 | 0 | 0 | 0 | 0 | 0 |
| 0 | 0 | 0 | 0 | 0 | 0 |
| 0 | 0 | 0 | 0 | 0 | 0 |
| 0 | 0 | 0 | 0 | 0 | 0 |
| 0 | 0 | 0 | 0 | 0 | 0 |

Intake Backfire Occurrences

Total intake backfires (recent) occurrences

Cumulative time since reset hours

Intake backfire action request Press to select action... ▾

Intake Backfire Events (Recent)

| Time (hours) | Occurrences |
|--------------|-------------|
| 0 | 0 |
| 0 | 0 |
| 0 | 0 |
| 0 | 0 |

DTC 1330 - Intake Backfire Detected

| Step | Action | Value(s) | Yes | No |
|------|---|----------|----------------|--------------------------------|
| 1 | Did you perform the On-Board (OBD) System Check? | - | Go to Step (2) | Go to OBD System Check Section |
| 2 | <p>When did the backfire occur (date, time, engine hours)?</p> <p>What conditions did the backfire occur in (engine starting, load step, etc)</p> <p>Was the backfire through the intake or exhaust?</p> <p>Did the backfire occur on the master or slave side of the engine (right or left)?</p> <p>Are any fault codes active or historic in the master AND slave ECM?</p> <p>Download all fault snapshots and flight data recorder ("FDR") and save for later.</p> | | Go to Step (3) | |
| 3 | <p>Inspect for any obvious issues that may have caused the event.</p> <ul style="list-style-type: none"> a. Fuel system b. Ignition system c. Electrical d. Base Engine e. Application | | System OK | Go to Step (4) |
| 4 | <p>Ignition Coil Wire Harness Inspection</p> <ul style="list-style-type: none"> a. Inspect the coil harness to engine harness connector as well as the ignition coil to harness connector for incorrectly pinned circuits. b. Inspect for connections that are not fully seated. c. Inspect for pushed back, loose, damaged, bent, or spread terminals. d. Inspect for damage to the wiring. e. Inspect for water ingress into the connectors. f. Inspect for debris in the terminals or circuit. g. Pay close attention to turbo boots for any signs of oil leak, weep, or seep onto ignition harness connectors. | | System OK | Go to Step (5) |

| | | | | |
|---|---|--|-----------|----------------|
| 5 | <p>Remove each ignition coil from the engine one at a time.</p> <ol style="list-style-type: none"> Inspect and document coils that are not fully seated or loose. Inspect and document ignition coil boots that may have torn or fragmented off before or during removal. Inspect for water or coolant around the body of the ignition coil. Inspect for presence of dielectric grease. | | System OK | Go to Step (6) |
|---|---|--|-----------|----------------|

| Step | Action | Value(s) | Yes | No |
|------|--|---|-----------|-----------------|
| 6 | <p>Remove each spark plug from engine one at a time.</p> <ol style="list-style-type: none"> Inspect for contamination (oil, fuel, coolant, other) Inspect spark plug condition using the guide below as a visual. | Replace spark plugs at 750 hours if not already replaced. | System OK | Go to Step (7) |
| 7 | <p>Measure resistance of spark plug.</p> <ol style="list-style-type: none"> Replace if the resistance is outside the acceptable value. Measurement requires very firm contact with the probes and may require scratching the surface to get a valid measurement. | 3.5-7 kOhm = Acceptable resistance value | System OK | Go to Step (8) |
| 8 | <p>*M-Series Engine Only Locate the crank sensor on bottom left-hand side of flywheel housing and perform a crank sensor gap verification.</p> | Crank sensor specification is 0.110" +/- 0.015 | System OK | Go to Step (9) |
| 9 | In cases where the engine is within 100 hours of a valve lash PM, remove valve covers from engine and perform a valve clearance inspection. Adjust as required and reassemble per instructions in the service manual. | Valve lash MUST BE performed on cold engine | System OK | Go to Step (10) |

| | | | | |
|----|--|--|--|-----------------|
| 10 | <p>Important - Reassemble the spark plugs, ignition coils, and ignition coil boots on the exact opposite cylinder which they were removed. Meaning install cylinder 1 ignition system parts onto cylinder 7 during the reassembly procedure.</p> <p>Install spark plugs.</p> <ul style="list-style-type: none"> a. Apply dielectric grease* to spark plug tip. b. Replace spark plugs if any visual issues were noted during the inspection. <p>Apply dielectric grease* to spark plug boots.</p> <p>Install and torque ignition coils and boots.</p> <p>Connect electrical connections to ignition coils.</p> <ul style="list-style-type: none"> a. Ensure the connections are tight and secured properly. <p>Replace any damaged components found during the evaluation.</p> <p>*Use Permatex Dielectric grease #81150 or equivalent</p> | Replace spark plugs if the spark plugs have 750 hours or more of operation | | Go to Step (11) |
|----|--|--|--|-----------------|

| Step | Action | Value(s) | Yes | No |
|------|--|----------|-----|----|
| 11 | <p>When you are ready to start the engine connect the 4G Display software to the engine wire harness diagnostic link connector.</p> <p>Turn VSW (B+) on to the engine so the 4G display connects to the engine ECM's.</p> <p>Load the DWELL plot file template into the 4G display software.</p> <p>Start a plot file recording.</p> <p>Start Engine.</p> <p>Monitor engine for any abnormal conditions, fault codes, fuel pressure expected vs actual.</p> <ul style="list-style-type: none"> a. Specifically, monitor fuel trims on both the primary and secondary side ECM's to ensure they are within acceptable limits. b. A DTC will not likely set until +/- 35%, ideally the fuel trims will be +/- 15% <p>Run the engine for 10 minutes while recording the plot file data.</p> <p>Save plot file data.</p> | | | |

DTC 1351 - Spark Plug or Coil Failure

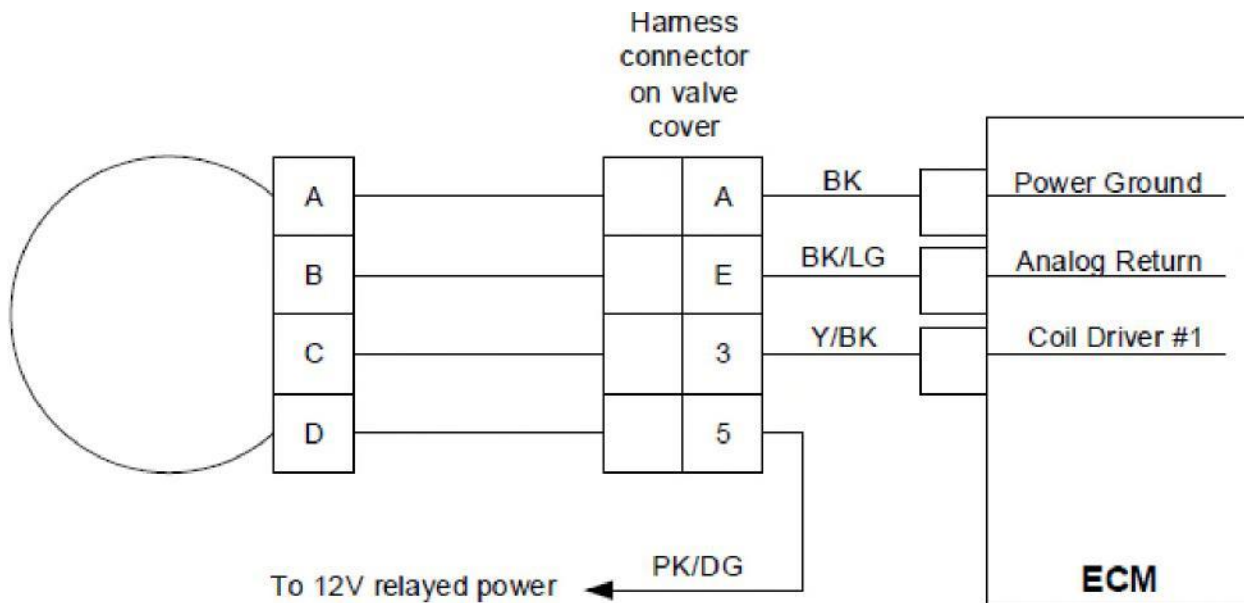

Conditions for setting the DTC

- Key on, Engine on
- Fault conditions: Ignition/spark drive circuitry (internal to the ECM) is overheating.
- MIL: ON
- Engine Shutdown

Fault Description

Coil driver #1 (correlates to DTC 1351) fires either the 1st cylinder in the firing order or the 1st cylinder in the block order depending on the configuration of the 'Injector/Spark.

Diagnostic Numbering' scheme as set in calibration. Drivers 2-10 (correlating to DTCs 13521360) follow in-kind.

Diagnostic Aids:

- Check plug gap on the cylinder associated with the fault.
- Check for loose connections at the coil and spark plugs. Look for evidence of charring or arcing around the spark plugs.
- Check coil resistance and verify that it is within specifications. Look for a short internal to the coil.
- Ensure the use of high-quality coils without a history of internal arcing or other failures.
- Verify that ambient conditions are not exceeding 85C on a continuous basis or 125C for short intervals. If so, verify that this fault stops occurring when ambient temperatures are lower.
- Verify the dwell time set in the diagnostic calibration is not set too long and that adaptive dwell is enabled.

DTC 1439 - Engine Oil Temperature Sensor High

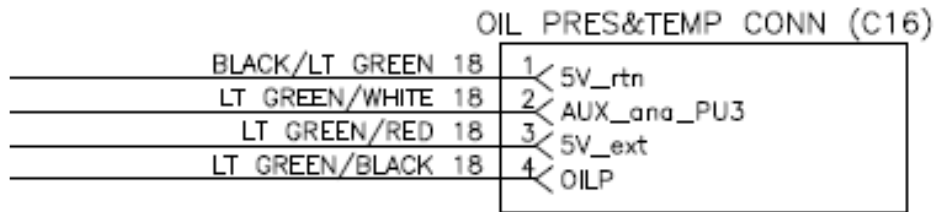

Conditions for setting the DTC

- Check Condition: Key On
- Fault condition: Temperature exceeds 235°F for over 3 seconds
- MIL: ON
- Engine Shutdown

Fault Description

The engine oil temperature sensor determines if the engine oil temperature is operating at normal operating temperatures given known air temperature and engine loads. Sensor allows for continuous monitoring after startup conditions are achieved.

Diagnostic Aid

- Check the engine oil level and refill if necessary.
- If the oil level is full, check the function of the switch. Disconnect the switch, clear the fault and try running the engine again. If the fault does not come back, check the oil temperature sensor switch.
- If the fault is still active with the switch disconnected, check the wiring for the switch to make sure it is not shorted to ground. The wiring originates at the Vehicle Interface Connector on the engine at terminal K. Disconnect the VIC and use an ohmmeter to check for a short to ground from pin K on the engine side of the VIC and on the OEM side of the VIC. Once you have determined whether the short is on the engine or in the OEM wiring you can begin searching for the short and repair it.
- Check for containment buildup or other non-leak-based failures that reduce the efficiency of the oil cooler.
- Check for damages in the rotating assembly that is causing excessive heat buildup, extra friction is going to be transferred into the oil in either loaded prime or continues applications, this will not be enough additional load and will come up as an increase in power output.

DTC 1572 - AUX DIG4 high - Coolant Level Stage 1 High Voltage

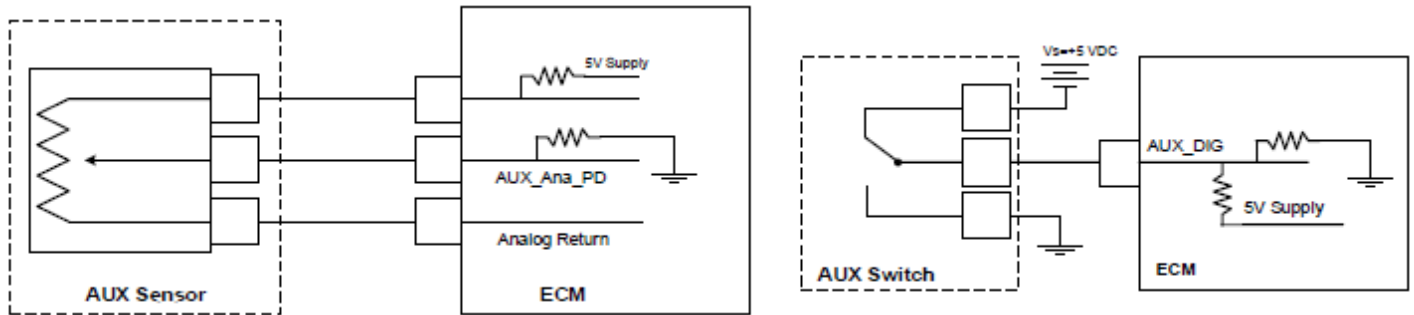

Conditions for Setting the DTC

- Check Condition: Key On
- Fault Condition: This fault is active when the voltage feedback from the sensor is ABOVE the limit defined in calibration.
- MIL: ON during active fault
- Engine Shutdown

Fault Description

The auxiliary digital input circuit is customer specific and can be used to perform an action based on a sensor that is switchable between two voltages as well as a center voltage. Typical uses of the auxiliary circuit include switches that activate particular software strategies, switches that act as vehicle safeties to trigger derate or shutdown conditions, or auxiliary senders used to drive gauges.

The circuit internal to the ECM is connected in parallel both with the regulated 5 VDC power supply as well as ground, so that when no load is connected to the circuit the feedback voltage is equal to either 32 VDC or 0 VDC, based on the switch state.

DTC 1572 - AUX DIG4 high - Coolant Level Stage 1 High Voltage

| Step | Action | Value(s) | Yes | No |
|------|--|--|----------------|--------------------------------|
| 1 | Did you perform the On-Board (OBD) System Check? | - | Go to Step (2) | Go to OBD System Check Section |
| 2 | Key ON, Engine On System Mode = "Running Operate engine at condition that set AUX_DIG(N) DTC | Is AUX_DIG(N) DTC active? | Go to Step (3) | Go to Step (4) |
| 3 | Key On, Engine Off Disconnect sensor/switch from harness Measure the input voltage of AUX_DIG(N) | Does DST or multi-meter display an AUX DIG(N) voltage ~2.5 VDC? | Go to Step (5) | Go to Step (6) |
| 4 | Intermittent Problem | | | |
| 5 | | Does DST or multi-meter display an AUX DIG(N) voltage >=5.5 VDC? | Go to Step (7) | Go to Step (8) |
| 6 | Faulty sensor | | | |
| 7 | Faulty ECM or Faulty Harness | | | |
| 8 | Replace with known good sensor and re-test | | | |

DTC 1574 - AUX DIG5 high - Coolant Level Stage 2 High Voltage

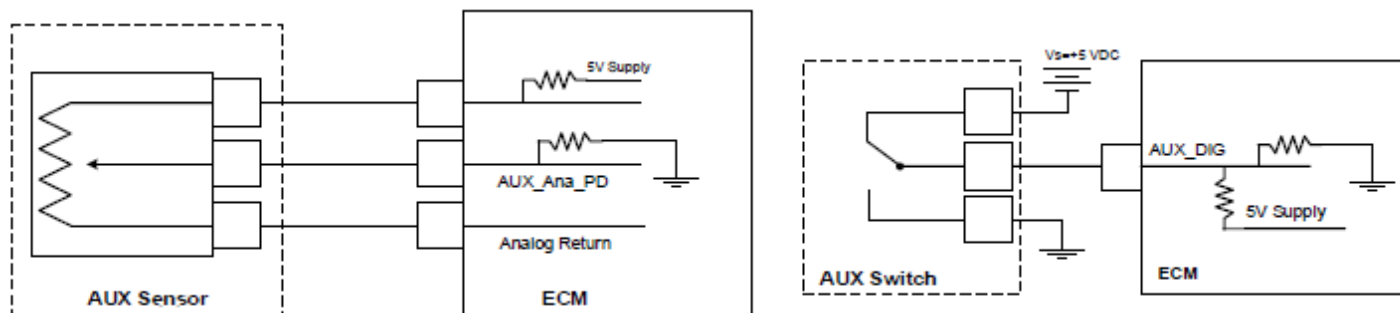

Conditions for Setting the DTC

- Check Condition: Key On
- Fault Condition: This fault is active when the voltage feedback from the sensor is ABOVE the limit defined in calibration.
- MIL: ON during active fault
- Engine Shutdown

Fault Description

The auxiliary digital input circuit is customer specific and can be used to perform an action based on a sensor that is switchable between two voltages as well as a center voltage. Typical uses of the auxiliary circuit include switches that activate particular software strategies, switches that act as vehicle safeties to trigger derate or shutdown conditions, or auxiliary senders used to drive gauges.

The circuit internal to the ECM is connected in parallel both with the regulated 5 VDC power supply as well as ground, so that when no load is connected to the circuit the feedback voltage is equal to either 32 VDC or 0 VDC, based on the switch state.

DTC 1574 - AUX DIG5 high - Coolant Level Stage 2 High Voltage

| Step | Action | Value(s) | Yes | No |
|------|--|--|----------------|--------------------------------|
| 1 | Did you perform the On-Board (OBD) System Check? | - | Go to Step (2) | Go to OBD System Check Section |
| 2 | Key ON, Engine On System Mode = "Running Operate engine at condition that set AUX_DIG(N) DTC | Is AUX_DIG(N) DTC active? | Go to Step (3) | Go to Step (4) |
| 3 | Key On, Engine Off Disconnect sensor/switch from harness Measure the input voltage of AUX_DIG(N) | Does DST or multi-meter display an AUX DIG(N) voltage ~2.5 VDC? | Go to Step (5) | Go to Step (6) |
| 4 | Intermittent Problem | | | |
| 5 | - | Does DST or multi-meter display an AUX DIG(N) voltage >=5.5 VDC? | Go to Step (7) | Go to Step (8) |
| 6 | Faulty sensor | | | |
| 7 | Faulty ECM or Faulty Harness | | | |
| 8 | Replace with known good sensor and re-test | | | |

DTC 1602 - Relay Off High Voltage

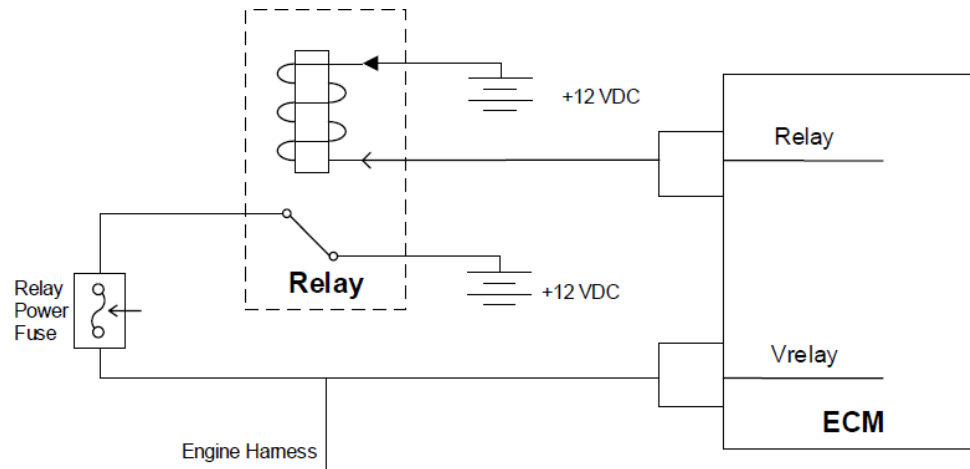

Conditions for Setting the DTC

- Check Condition: Engine Running / Stopped Checked
- Fault Condition: Relay control off with VRelay voltage >80.0% Vbat
- MIL: ON during active fault

Fault Description

Certain models of the 4G ECM source power for part of the internal circuitry from the VRelay circuit, which also supplies power to the engine harness. The VRelay is controlled by the ECM using one of the low side (LS) driver

This fault sets if the output for the power relay is off, with VRelay voltage greater than a calibratable percentage of battery voltage.

DTC 1602 - Relay Off High Voltage

| Step | Action | Value(s) | Yes | No |
|------|---|--|----------------|--------------------------------|
| 1 | Did you perform the On-Board (OBD) System Check? | - | Go to Step (2) | Go to OBD System Check Section |
| 2 | Key ON, Engine Off Locate VRelay voltage on EDIS RawVolts page | Is VRelay >%VBat specified in the calibration? | Go to Step (3) | Go to Step (4) |
| 3 | Locate power relay in the harness and remove it. | Did EDIS VRelay voltage go to 0.0V? | Go to Step (5) | Go to Step (5) |
| 4 | Fault condition not present | | | |
| 5 | Replace the Power relay with a new unit and recheck. | | | |
| 6 | Locate and repair short to power in the wiring harness. | | | |

DTC 1603 - Relay On Low Voltage

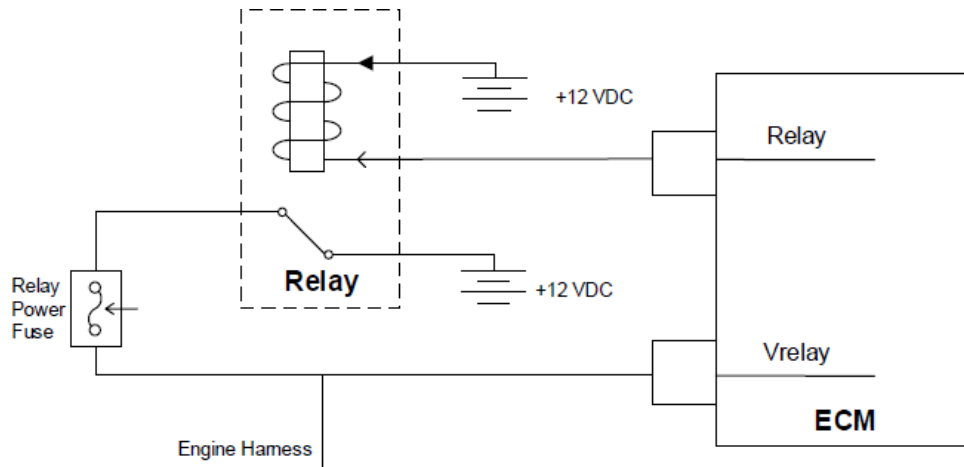

Conditions for Setting the DTC

- Check Condition: Engine Running / Stopped Checked
- Fault Condition: Relay control on with feedback <20.0% Vbat
- Injectors relay powered: Yes
- Ignition coils relay powered: Yes
- MIL: ON during active fault

Fault Description

Certain models of the 4G ECM source power for part of the internal circuitry from the VRelay circuit, which also supplies power to the engine harness. The VRelay is controlled by the ECM using one of the low side (LS) drivers.

This fault sets if the output for the power relay is on, with VRelay voltage less than a calibratable percentage of battery voltage.

Please note:

- 1) If the injectors are relay powered (selection dropdown set to YES), all injector faults will be ignored while this fault is active.
- 2) If the ignition coils are relay powered (selection dropdown set to YES), all injector faults will be ignored while this fault is active.

DTC 1603 - Relay Off High Voltage

| Step | Action | Value(s) | Yes | No |
|------|---|--|----------------|--------------------------------|
| 1 | Did you perform the On-Board (OBD) System Check? | - | Go to Step (2) | Go to OBD System Check Section |
| 2 | Key ON, Engine On Locate VRelay voltage on EDIS RawVolts page | Is VRelay <%VBat specified in the calibration? | Go to Step (3) | Go to Step (4) |
| 3 | - | Are DTCs 685 or 6987 set? | Go to Step (5) | Go to Step (5) |
| 4 | Fault condition not present | | | |
| 5 | Refer to diagnostics for the set fault. Repair and retest. | | | |
| 6 | Check power relay fuse. Repair as needed. Check for battery voltage to and from the power relay. Repair as needed. | | | |

DTC 1612 - RTI 1 Loss

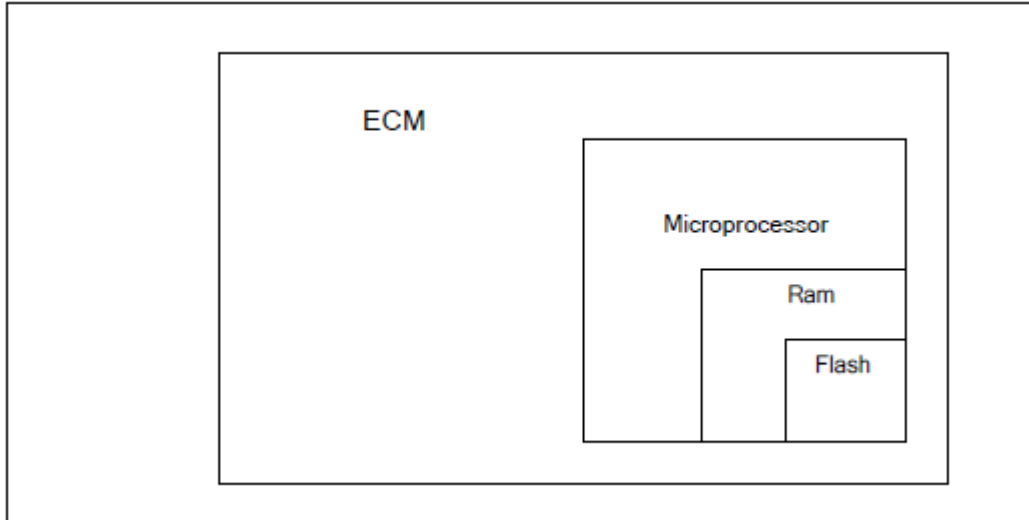

Conditions for Setting the DTC

- Check Condition: Key on
- Fault Condition: Internal microprocessor error
- MIL: ON
- Adaptive: Disabled for the remainder of the key-ON cycle
- Engine shutdown will occur

Circuit Description

The ECM has several internal checks that must be satisfied each time an instruction is executed. Several different things can happen within the microprocessor that will cause this fault. The ECM will attempt to reset itself in the event this fault is set. The MIL command is on and will remain on until the code is cleared using the DST. The engine will shut down if this code occurs.

DTC 1612 - RTI 1 Loss

| Step | Action | Value(s) | Yes | No |
|------|--|----------|----------------|--|
| 1 | Did you perform the On-Board (OBD) System Check? | - | Go to Step (2) | Go to OBD System Check Section |
| 2 | Key ON, Engine Running DST (Diagnostic Scan Tool) connected in System Data Mode Clear system fault code Does DTC 1612 reset with the engine idling? | | Go to Step (3) | Intermittent problem Go to Interittent section |
| 3 | Check ECM power and ground circuits Did the power and ground circuits check OK? | | Go to Step (4) | Repair the circuit as necessary. Refer to Wiring Repairs in Engine Electrical. |
| 4 | Replace ECM Is the replacement complete? | | Go to Step (5) | - |
| 5 | Remove all test equipment except the DST. Connect any disconnected components, fuses, etc. Using the DST clear DTC information from the ECM. Turn the ignition OFF and wait 30 seconds. Start the engine and operate the vehicle to full operating temperature Observe the MIL Observe engine performance and drivability After operating the engine within the test parameters of DTC-1612 check for any stored codes. Does the engine operate normally with no stored codes? | | System OK | Go to OBD System Check |

DTC 1613 - RTI 2 Loss

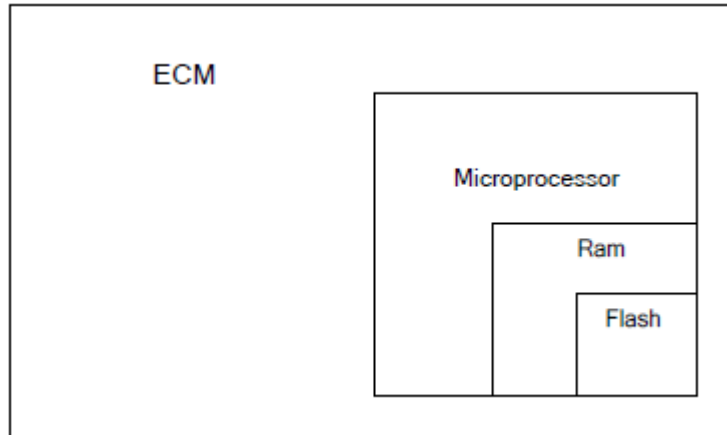

Conditions for Setting the DTC

- Check Condition: Key on
- Fault Condition: Internal microprocessor error
- MIL: ON
- Adaptive: Disabled for the remainder of the key-ON cycle
- Engine shutdown will occur

Circuit Description

The ECM has several internal checks that must be satisfied each time an instruction is executed. Several different things can happen within the microprocessor that will cause this fault. The ECM will attempt to reset itself in the event this fault is set. The MIL command is on and will remain on until the code is cleared using the DST. The engine will shut down if this code occurs.

DTC 1613 - RTI 2 Loss

| Step | Action | Value(s) | Yes | No |
|-------------|--|---|----------------|--------------------------------|
| 1 | Did you perform the On-Board (OBD) System Check? | - | Go to Step (2) | Go to OBD System Check Section |
| 2 | Key On, Engine Running System Data Mode Clear System Fault | Does DTC 1613 reset with engine idling? | Go to Step (3) | Go to Step (4) |
| 3 | Check all power and ground circuits to ECM | Are all circuits, ok? | Go to Step (5) | Go to Step (6) |
| 4 | Fault is intermittent | | | |
| 5 | Replace ECM with known good part and retest | | | |
| 6 | Repair wiring to ECM and retest | | | |

DTC 1614 - RTI 3 Loss

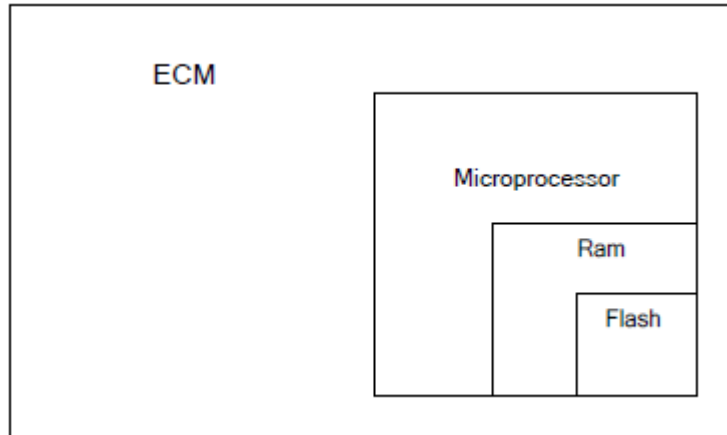

Conditions for Setting the DTC

- Check Condition: Key on
- Fault Condition: Internal microprocessor error
- MIL: ON
- Adaptive disabled for the remainder of the key-ON cycle
- Engine shutdown will occur

Circuit Description

The ECM has several internal checks that must be satisfied each time an instruction is executed. Several different things can happen within the microprocessor that will cause this fault. The ECM will attempt to reset itself in the event this fault is set. The MIL command is on and will remain on until the code is cleared using the DST. The engine will shut down if this code occurs.

DTC 1614 - RTI 3 Loss

| Step | Action | Value(s) | Yes | No |
|------|--|---|----------------|--------------------------------|
| 1 | Did you perform the On-Board (OBD) System Check? | - | Go to Step (2) | Go to OBD System Check Section |
| 2 | Key On, Engine Running System Data Mode Clear System Fault | Does DTC 1614 reset with engine idling? | Go to Step (3) | Go to Step (4) |
| 3 | Check all power and ground circuits to ECM | Are all circuits, ok? | Go to Step (5) | Go to Step (6) |
| 4 | Fault is intermittent | | | |
| 5 | Replace ECM with known good part and retest | | | |
| 6 | Repair wiring to ECM and retest | | | |

DTC 1615 - A/D Loss

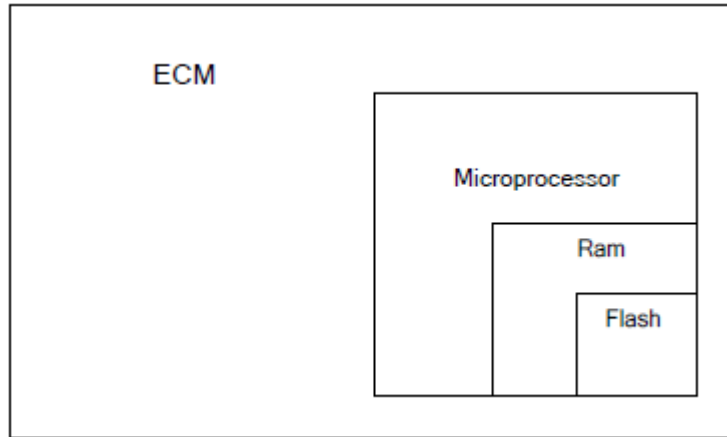

Conditions for Setting the DTC

- Check Condition: Key on
- Fault Condition: Internal microprocessor error
- MIL: ON
- Adaptive disabled for the remainder of the key-ON cycle
- Engine shutdown will occur

Circuit Description

The ECM has several internal checks that must be satisfied each time an instruction is executed. Several different things can happen within the microprocessor that will cause this fault. The ECM will attempt to reset itself in the event this fault is set. The MIL command is on and will remain on until the code is cleared using the DST. The engine will shut down if this code occurs.

DTC 1615 - A/D Loss

| Step | Action | Value(s) | Yes | No |
|-------------|--|------------------------------------|----------------|--------------------------------|
| 1 | Did you perform the On-Board (OBD) System Check? | - | Go to Step (2) | Go to OBD System Check Section |
| 2 | Key On, Engine Running System Data Mode Clear System Fault | Does DTC reset with engine idling? | Go to Step (3) | Go to Step (4) |
| 3 | Check all power and ground circuits to ECM | Are all circuits, ok? | Go to Step (5) | Go to Step (6) |
| 4 | Fault is intermittent | | | |
| 5 | Replace ECM with known good part and retest | | | |
| 6 | Repair wiring to ECM and retest | | | |

DTC 1616 - Invalid Interrupt

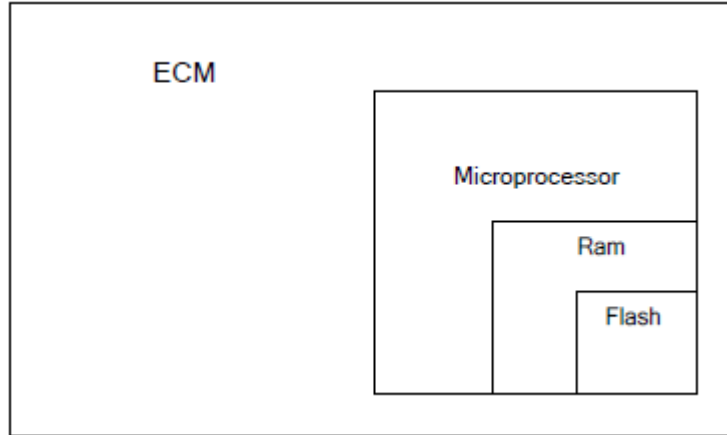

Conditions for Setting the DTC

- Check Condition: Key on
- Fault Condition: Internal microprocessor error
- MIL: ON
- Adaptive disabled for the remainder of the key-ON cycle
- Engine Shutdown will occur

Circuit Description

The ECM has several internal checks that must be satisfied each time an instruction is executed. Several different things can happen within the microprocessor that will cause this fault. The ECM will attempt to reset itself in the event this fault is set. The MIL command is on and will remain on until the code is cleared using the DST. The engine will shut down if this code occurs.

DTC 1616 - Invalid Interrupt

| Step | Action | Value(s) | Yes | No |
|-------------|--|------------------------------------|----------------|--------------------------------|
| 1 | Did you perform the On-Board (OBD) System Check? | - | Go to Step (2) | Go to OBD System Check Section |
| 2 | Key On, Engine Running System Data Mode Clear System Fault | Does DTC reset with engine idling? | Go to Step (3) | Go to Step (4) |
| 3 | Check all power and ground circuits to ECM | Are all circuits, ok? | Go to Step (5) | Go to Step (6) |
| 4 | Fault is intermittent | | | |
| 5 | Replace ECM with known good part and retest | | | |
| 6 | Repair wiring to ECM and retest | | | |

DTC 1625 - J1939 Shutdown Request

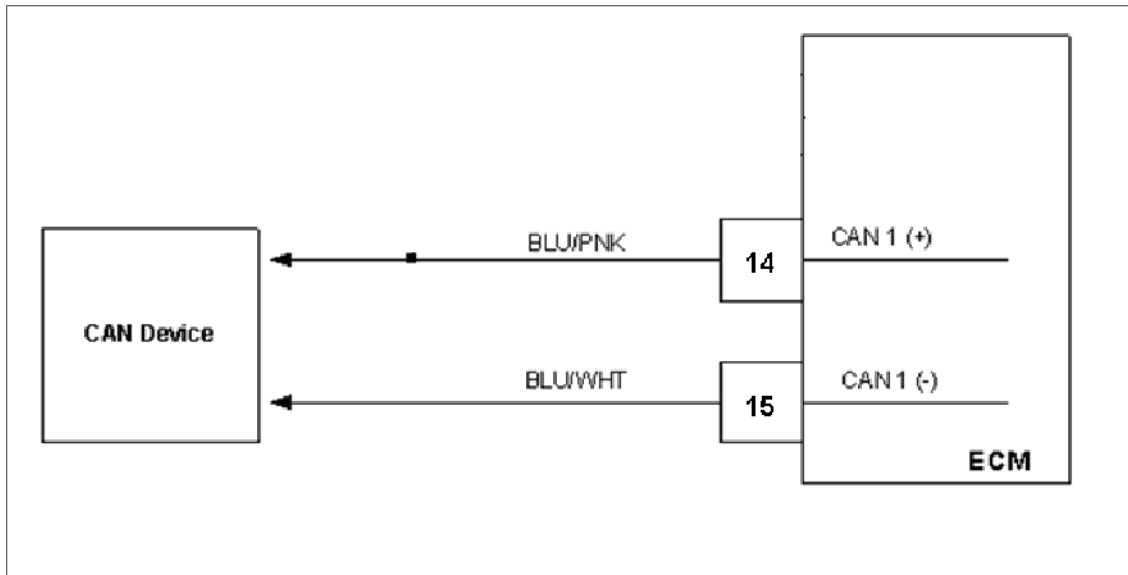

Conditions for Setting the DTC

- Check Condition: Key On
- Fault Condition: Master ECM receives a shutdown request over the CAN network
- MIL: ON during active fault
- Engine Shutdown

Fault Description

This fault is triggered when a device connected to the CAN network triggers an engine shutdown. The MIL will light and the engine will shut down.

Diagnostic Aids

This fault is triggered in the master ECM whenever there is a fault in the slave ECM that requires the engine to shut down. The slave ECM doesn't have the authority to shut down the engine on its own, so it sends a shutdown request over the CAN network to the master ECM to get the engine to shut down. Connect to the slave ECU and check all stored fault codes to find the fault that triggered the shutdown on the master side.

If there are no stored faults on the slave ECM, check any other devices connected to the CAN network that are capable of triggering an engine shutdown, such as genset controllers or pump controllers.

DTC 1626 - CAN1 Tx Failure

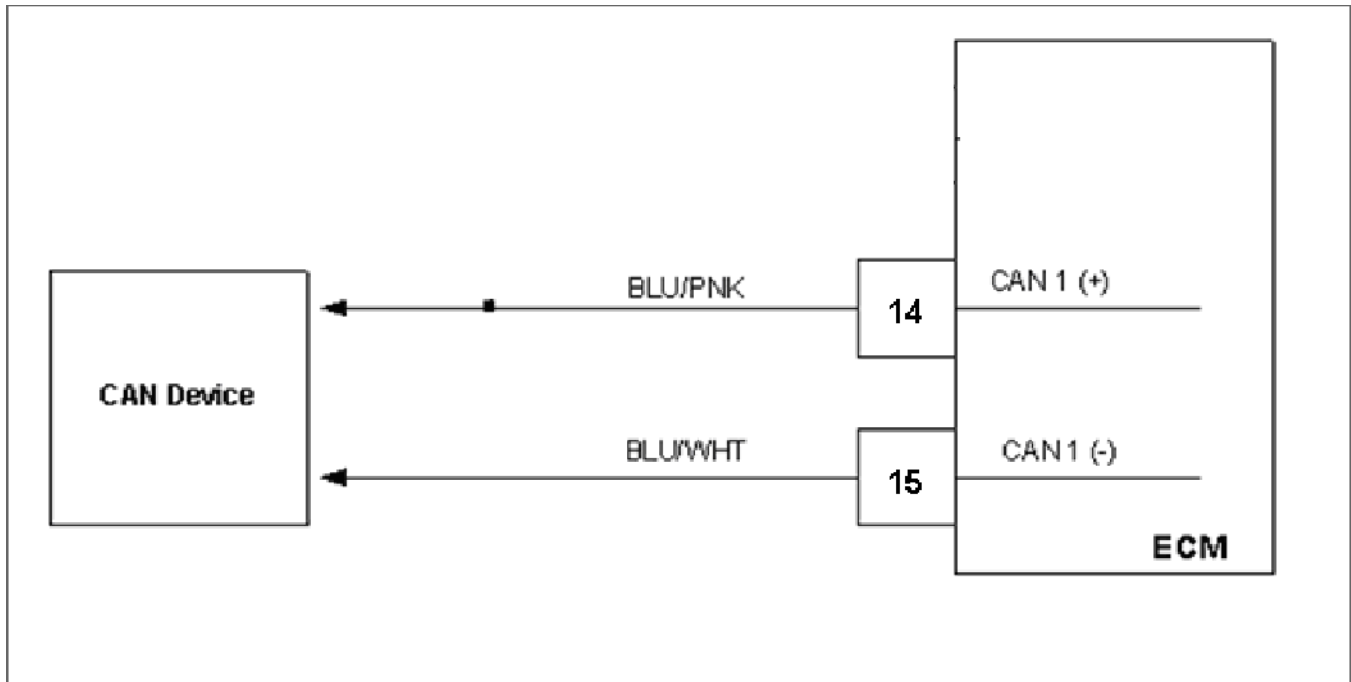

Conditions for Setting the DTC

- Check Condition: Engine running
- Fault Condition: CAN Tx error 120 packets lost within 1 second
- MIL: ON

Circuit description

The CAN bus (controller area network) is used by the ECM to communicate with other digital devices used throughout the fuel system. Information is sent over the CAN bus in digital information "packets" that contain information for various control functions. This fault will set if the ECM broadcasts 120 packets to the network that are not received within a one second time period. The MIL command is ON.

Diagnostic Aides

- Verify that all CAN devices are powered and properly grounded
- Verify that the CAN1 network is properly terminated
- Check CAN1 wire routing with respect to noise sources (ignition coils, spark plug coil wires, etc.) and shield if necessary
- Check CAN1 (+) and (-) wires for short circuits

DTC 1627 - CAN1 Rx Failure

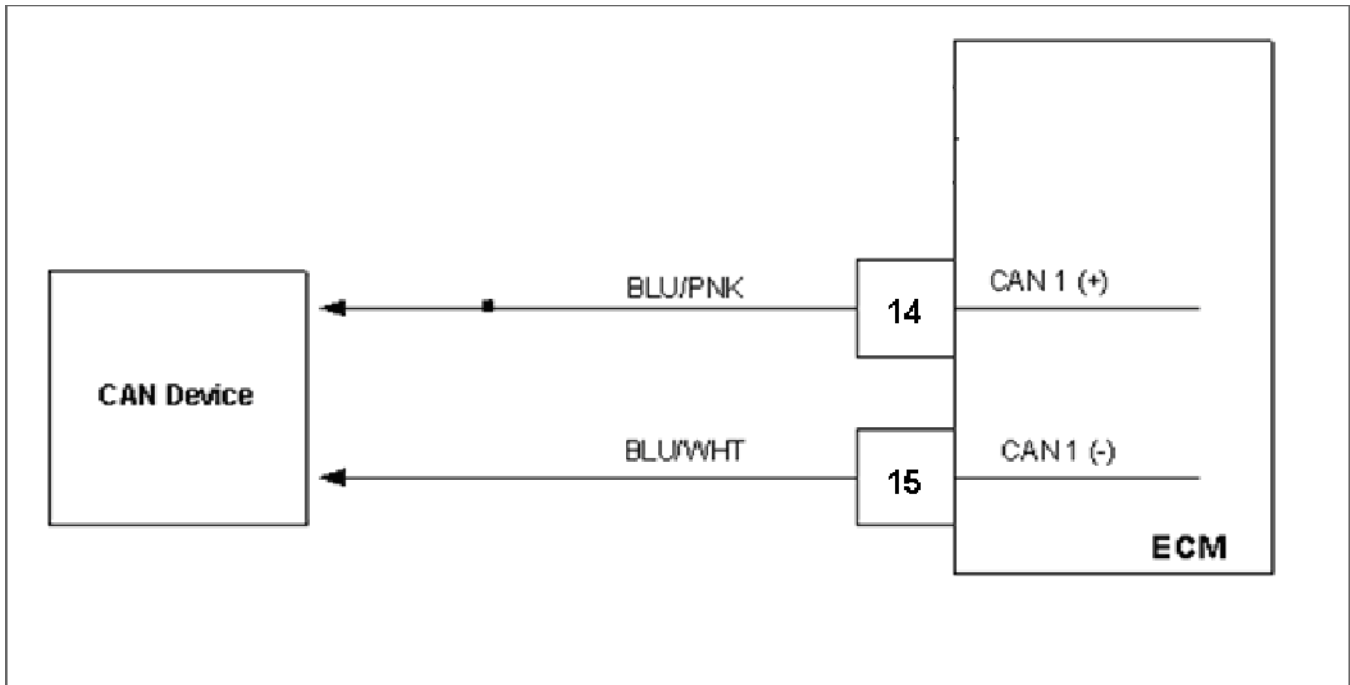

Conditions for Setting the DTC

- Check Condition: Engine running
- Fault Condition: CAN1 Rx error 120 packets lost within 1 second
- MIL: ON

Circuit description

The CAN bus (controller area network) is used by the ECM to communicate with other digital devices used throughout the fuel system. Information is sent over the CAN bus in digital information "packets" that contain information for various control functions. This fault will set if the ECM detects 120 packets lost within a one second time period. The MIL command is ON.

DTC 1627 - CAN1 Rx Failure

| Step | Action | Value(s) | Yes | No |
|------|--|----------|--|---|
| 1 | Did you perform the On-Board (OBD) System Check? | - | Go to Step (2) | Go to OBD System Check Section |
| 2 | Key ON, Engine Running DST (Diagnostic Scan Tool) connected in System Data Mode Clear system fault code Does DTC1627 reset with the engine idling? | | Go to Step (3) | Intermittent problem Go to Intermittent section |
| 3 | Check that the ECM power connection C019 is clean, tight and in the proper location. Check that the ECM ground connection C010 is clean, tight and in the proper location. Are the power and ground circuits OK? | | Go to Step (4) | Repair the circuit as necessary. Refer to Wiring Re-pairs in Engine Electrical. |
| 4 | Using a DVOM check for continuity between ECM pins 14 and 15 Do you have continuity between them? | | Repair the shorted circuit as necessary. Refer to Wiring Repairs in Engine Electrical. | Go to Step (5) |
| 5 | Using a DVOM check for continuity to engine ground on pin 15. Do have continuity to engine ground? | | Repair the shorted to ground circuit as necessary. Refer to Wiring Repairs in Engine Electrical. | Go to Step (6) |
| 6 | Using a DVOM check for continuity to battery positive on pin 15. Do have continuity between them? | | Repair the shorted to ground circuit as necessary. Refer to Wiring Repairs in Engine Electrical. | Go to Step (7) |
| 7 | Replace the ECM Is the replacement complete? | | Go to Step (8) | - |

| Step | Action | Value(s) | Yes | No |
|------|---|----------|-----------|------------------------|
| 8 | <p>Remove all test equipment except the DST. Connect any disconnected components, fuses, etc.</p> <p>Using the DST clear DTC information from the ECM.</p> <p>Turn the ignition OFF and wait 30 seconds. Start the engine and operate the vehicle to full operating temperature</p> <p>Observe the MIL</p> <p>Observe engine performance and drivability After operating the engine within the test parameters of DTC-1627 check for any stored codes. Does the engine operate normally with no stored codes?</p> | | System OK | Go to OBD System Check |

DTC 1628 - CAN Address Conflict

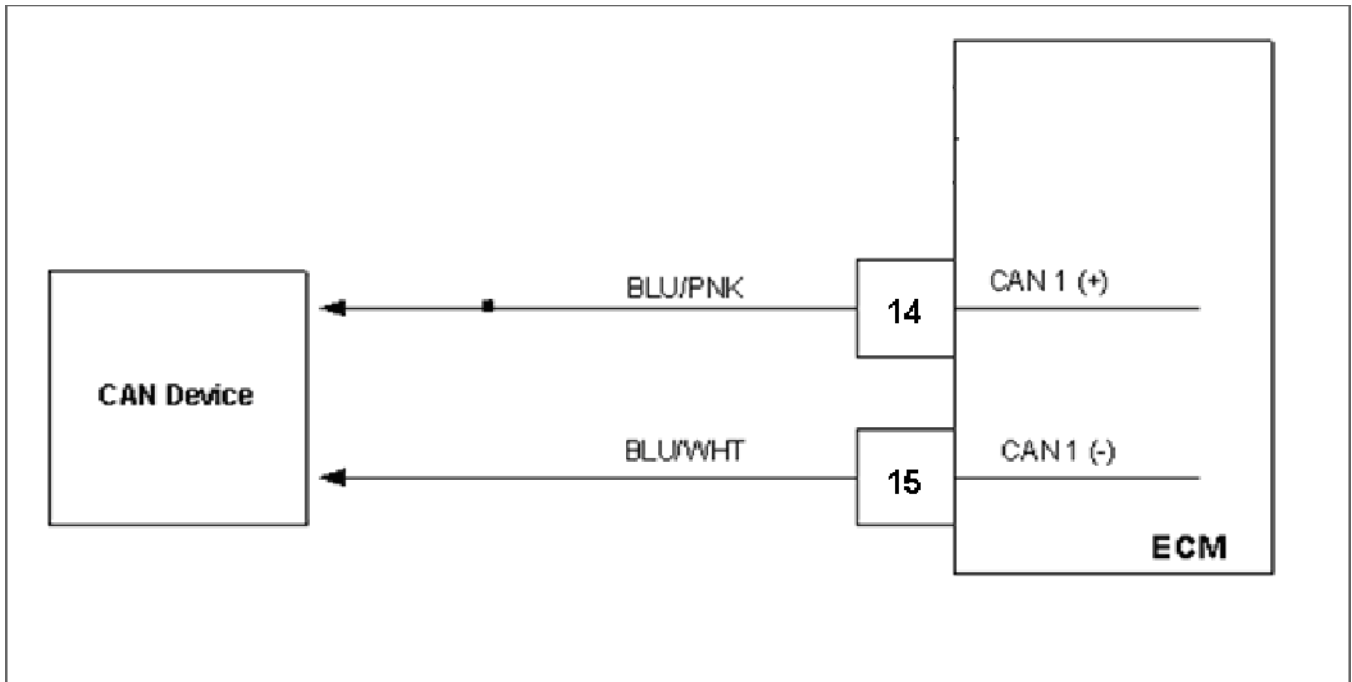

Conditions for Setting the DTC

- Check Condition: Engine running
- Fault Condition: 5 or more address conflict errors
- MIL: ON

Circuit description

The CAN bus (controller area network) is used by the ECM to communicate with other digital devices used throughout the fuel system. Information is sent over the CAN bus in digital information "packets" that contain information for various control functions. Individual devices are assigned network addresses. This fault will set if the ECM detects an address conflict, such as two devices with the same address. This is usually not due to an in-field failure and may be the results of "add on" CAN devices.

DTC 1628 - CAN Address Conflict

| Step | Action | Value(s) | Yes | No |
|------|--|----------|--|---|
| 1 | Did you perform the On-Board (OBD) System Check? | - | Go to Step (2) | Go to OBD System Check Section |
| 2 | Key ON, Engine Running DST (Diagnostic Scan Tool) connected in System Data Mode Clear system fault code Does DTC1628 reset with the engine idling? | | Go to Step (3) | Intermittent problem Go to Intermittent section |
| 3 | Key OFF Disconnect one CAN device Clear DTC 1628 Key ON (start engine if possible if not continue cranking for at least 3 seconds) Wait 5 seconds Does DTC 1628 re-set? | | Repeat step 3 until all CAN devices have been disconnected one at a time | Contact the CAN device manufacturer for additional CAN address information Go to Step (4) |
| 4 | Has the CAN device been replaced, or address conflict resolved? | | Go to Step (5) | - |
| 5 | Remove all test equipment except the DST. Connect any disconnected components, fuses, etc. Using the DST clear DTC information from the ECM. Turn the ignition OFF and wait 30 seconds. Start the engine and operate the vehicle to full operating temperature Observe the MIL Observe engine performance and drivability After operating the engine within the test parameters of DTC-1628 check for any stored codes. Does the engine operate normally with no stored codes? | | System OK | Go to OBD System Check |

DTC 1646 - CAN2 Tx Failure

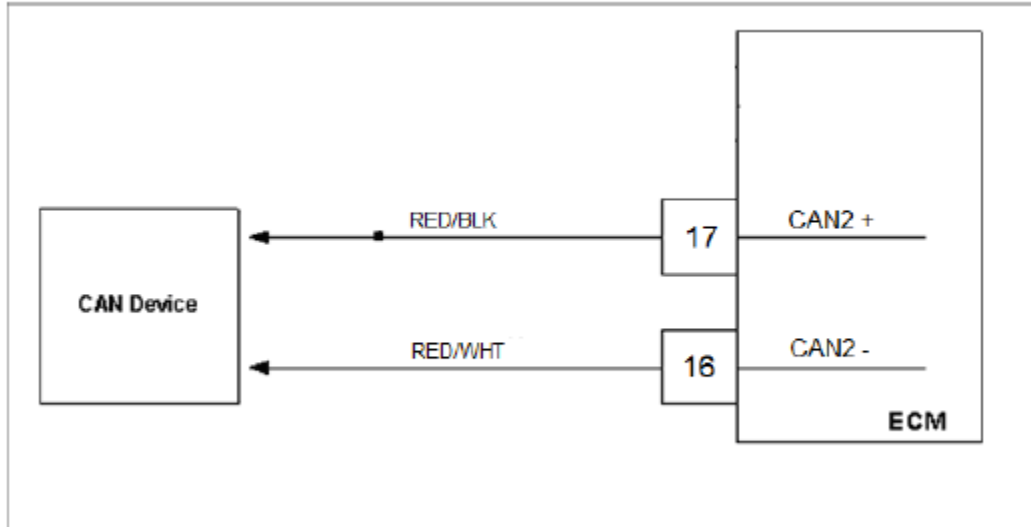

Conditions for setting the DTC

- Check Condition: Engine running
- Fault Condition: CAN Tx error 120 packets lost within 1 second
- MIL: ON

Circuit description

The CAN bus (controller area network) is used by the ECM to communicate with other digital devices used throughout the fuel system. Information is sent over the CAN bus in digital information "packets" that contain information for various control functions. This fault will set if the ECM broadcasts 120 packets to the network that are not received within a one second time period. The MIL command is ON.

Diagnostic Aides

- Verify that all CAN devices are powered and properly grounded
- Verify that the CAN2 network is properly terminated
- Check CAN2 wire routing with respect to noise sources (ignition coils, spark plug coil wires, etc.) and shield if necessary
- Check CAN2 (+) and (-) wires for short circuits

DTC 1648 - CAN2 Rx Failure

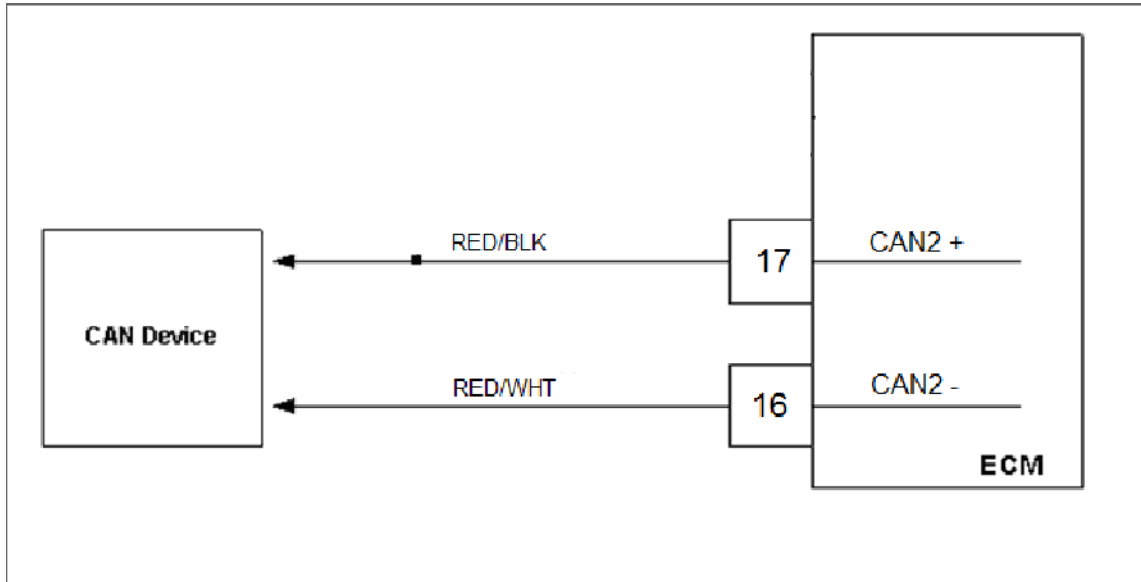

Conditions for Setting the DTC

- Check Condition: Engine running
- Fault Condition: CAN2 Rx error 120 packets lost within 1 second
- MIL: ON

Circuit description

The CAN bus (controller area network) is used by the ECM to communicate with other digital devices used throughout the fuel system. Information is sent over the CAN bus in digital information "packets" that contain information for various control functions. This fault will set if the ECM detects 120 packets lost within a one second time period. The MIL command is ON.

DTC 1650 – CAN2 Address Conflict Failure

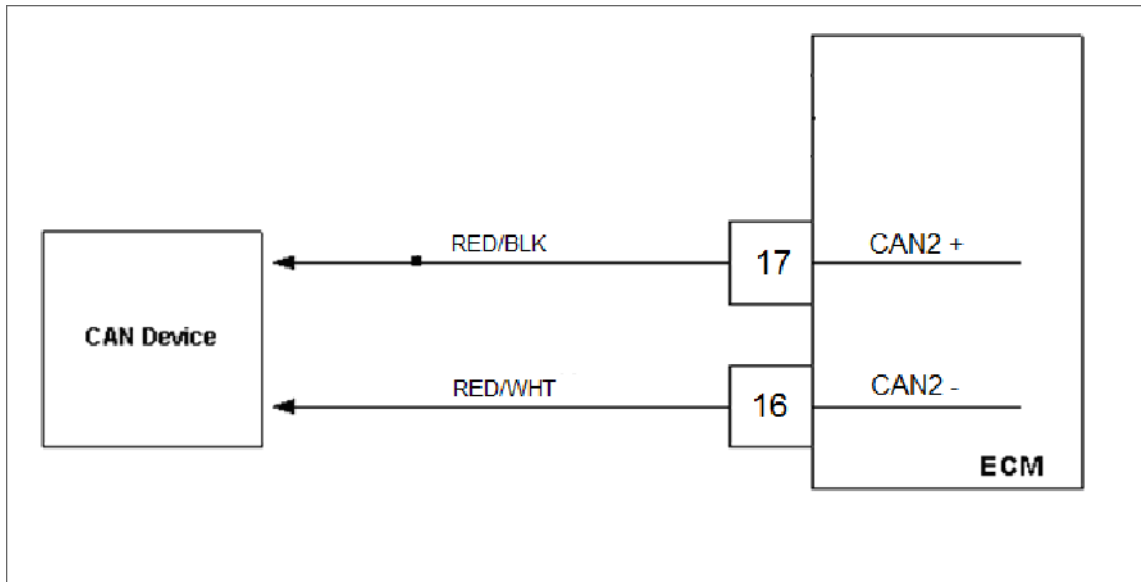

Conditions for Setting the DTC

- Check Condition: Engine running
- Fault Condition: 5 or more address conflict errors
- MIL: ON

Circuit description

The CAN bus (controller area network) is used by the ECM to communicate with other digital devices used throughout the fuel system. Information is sent over the CAN bus in digital information "packets" that contain information for various control functions. Individual devices are assigned network addresses. This fault will set if the ECM detects an address conflict, such as two devices with the same address. This is usually not due to an in-field failure and may be the results of "add on" CAN devices.

DTC 1673 - Calibration Configuration Error

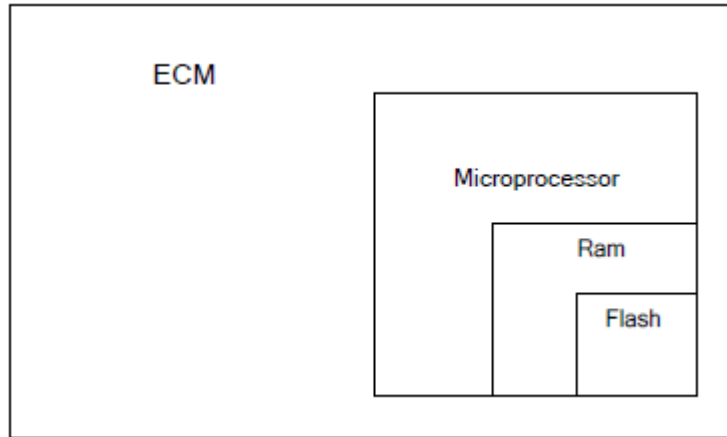

Conditions for Setting the DTC

- Check Condition: Engine running
- Fault Condition: Specific calibration variable checks do not return expected results
- MIL: ON
- Adaptive disabled, engine derated

Circuit description

The ECM checks certain safety-related calibration variables for acceptable values or ranges. This fault becomes active when these variable checks do not return the expected results.

Diagnostic Aids

Clear the fault and run the engine again. If the fault returns, contact PSI.

DTC 1674 - Hardware ID Failure

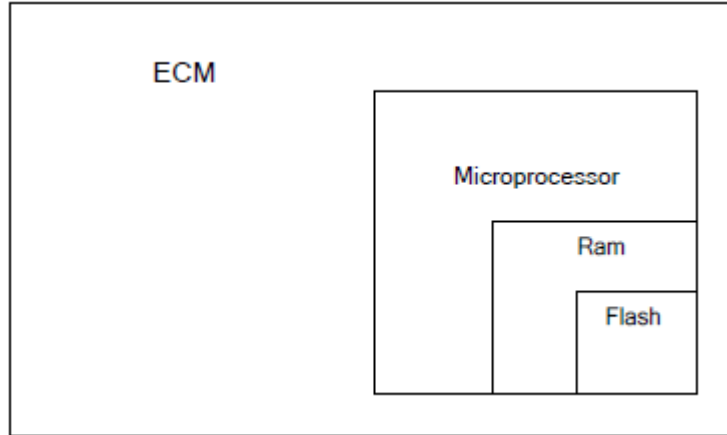

Conditions for Setting the DTC

- Check Condition: Key On
- Fault Condition: MOT file is too old for the given hardware revision level
- MIL: ON
- Adaptive disabled, engine derated

Circuit description

The ECM checks the MOT file against hardware ID tags that indicate the current ECM hardware revision level. This fault will set when programming the ECM with a MOT file that is too old for the given hardware and revision level.

Diagnostic Aids

Clear the fault and run the engine again. If the fault returns, contact PSI.

DTC 1674 - Hardware ID Failure

| Step | Action | Value(s) | Yes | No |
|------|--|---|----------------|--------------------------------|
| 1 | Did you perform the On-Board (OBD) System Check? | - | Go to Step (2) | Go to OBD System Check Section |
| 2 | Key ON, Engine On System Mode="Running" Operate engine at idle Clear system fault | Did DTC 1674 occur after flashing new MOT file? | Go to Step (3) | Go to Step (4) |
| 3 | Recompile with latest software and re-flash the ECM | Does DTC 1674 clear after reflashing with new software? | | Go to Step (8) |
| 4 | - | Does DTC 1674 reset with engine idling? | Go to Step (5) | Go to Step (6) |
| 5 | Check all power and ground circuits to ECM | Are all circuits ok? | Go to Step (7) | Go to Step (8) |
| 6 | Fault is intermittent | | | |
| 7 | Repair wiring to ECM and retest | | | |
| 8 | Replace ECM with known good part and retest | | | |

DTC 2111 - Unable To Reach Lower TPS

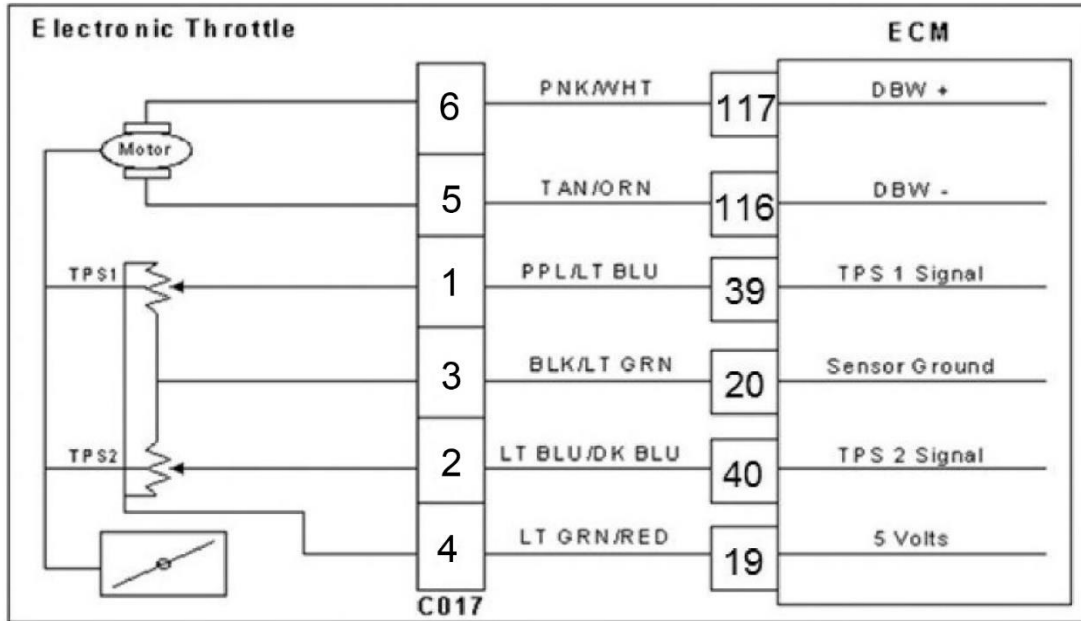

Conditions for Setting the DTC

- Check Condition: Cranking or Running
- Fault Condition: Actual throttle position is 20% greater than the throttle command
- MIL: ON during active fault
- Engine shutdown

Circuit Description

Dual throttle position sensors are used within the throttle that use variable resistors to determine signal voltage based on throttle plate position. When the throttle is closed TPS1 will read low voltage and TPS2 will read high voltage. The TPS 1 and TPS 2 percentages are calculated from these voltages. Although the voltages are different, the calculated values for the throttle position percentages should be very close to the same. The TPS values are used by the ECM to determine if the throttle is opening as commanded. This fault will set if the actual throttle position is 20% greater than the throttle command. During this active fault the MIL command is ON and the engine will shut down.

Diagnostic Aid

This fault is most often caused by a mechanical problem with the throttle. Testing the engine with a known good throttle or swapping the throttles side to side on a G-drive engine and seeing if the problem moves are good ways to diagnose a stuck throttle.

DTC 2111 - Unable To Reach Lower TPS

| Step | Action | Value(s) | Yes | No |
|------|--|----------|---|---|
| 1 | Did you perform the On-Board (OBD) System Check? | - | Go to Step (2) | Go to OBD System Check Section |
| 2 | Key ON, Engine OFF DST (Diagnostic Scan Tool) connected in DBW (Drive By Wire) test mode Depress foot pedal until the throttle command is between 63%-68% Is the TPS 1 voltage greater than 2.0 volts? | | Go to Step (3) | Intermittent problem Go to Intermittent section |
| 3 | Key OFF Disconnect electronic throttle connector C017 Probe TPS 1 signal pin 1 with a test light connected to battery voltage Key ON Does DST display TPS 1 voltage less than 0.2 volts? | | Go to Step (6) | Go to Step (4) |
| 4 | Key OFF Disconnect ECM wire harness connector C001 Key ON Using a DVOM check for voltage between throttle connector TPS 1 signal pin 1 and engine ground Do you have voltage? | | Repair the circuit as necessary. Refer to Wiring Repairs in Engine Electrical. | Go to Step (5) |
| 5 | Replace ECM Is the replacement complete? | | Go to Step (13) | - |
| 6 | Probe sensor ground circuit at ECM connector C001 with a test light connected to battery voltage Does the test light come on? | | Go to Step (9) | Go to Step (7) |
| 7 | Key OFF Disconnect ECM wire harness connector C001 Using a DVOM check for continuity between throttle connector signal ground pin 3 and ECM signal ground circuit pin 20 Do you have continuity between them? | | Go to Step (8) | Repair the circuit as necessary. Refer to Wiring Repairs in Engine Electrical. |
| 8 | Replace ECM Is the replacement complete? | | Go to Step (13) | - |
| 9 | Check throttle for foreign object in bore Did you find a foreign object in the bore? | | Go to Step (10) | Go to Step (11) |
| 10 | Remove foreign object Is the removal complete? | | Go to Step (13) | - |

| | | | | |
|----|---|--|---|-----------------|
| 11 | Inspect the throttle wire harness connector terminals for damage, corrosion or contamination Did you find the problem? | | Repair the circuit as necessary. Refer to Wiring Repairs in Engine Electrical. | Go to Step (10) |
|----|---|--|---|-----------------|

| Step | Action | Value(s) | Yes | No |
|------|--|----------|-----------------|------------------------|
| 12 | Replace throttle Is the replacement complete? | | Go to Step (13) | - |
| 13 | Remove all test equipment except the DST. Connect any disconnected components, fuses, etc. Using the DST clear DTC information from the ECM. Turn the ignition OFF and wait 30 seconds. Start the engine and operate the vehicle to full operating temperature Observe the MIL Observe engine performance and drivability After operating the engine within the test parameters of DTC-2111 check for any stored codes. Does the engine operate normally with no stored codes? | | System OK | Go to OBD System Check |

DTC 2112 - Unable To Reach Higher TPS

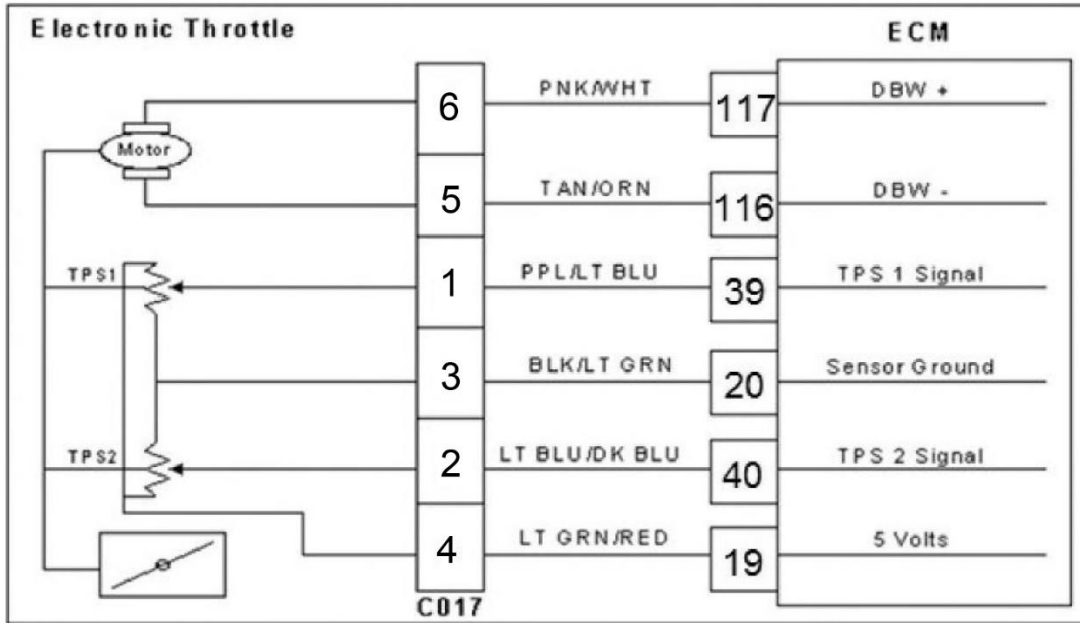

Conditions for Setting the DTC

- Check Condition: Cranking or Running
- Fault Condition: Actual throttle position is 20% less than the throttle command
- MIL: ON during active fault
- Engine shutdown

Circuit Description

Dual throttle position sensors are used within the throttle that use variable resistors to determine signal voltage based on throttle plate position. TPS 1 will read low voltage when closed and TPS 2 will read high voltage when closed. The TPS 1 and TPS 2 percentages are calculated from these voltages. Although the voltages are different, the calculated values for the throttle position percentages should be very close to the same. The TPS values are used by the ECM to determine if the throttle is opening as commanded. This fault will set if the actual throttle position is 20% less than the throttle command. The MIL command is ON and the engine will shut down.

Diagnostic Aid

This fault is most often caused by a mechanical problem with the throttle. Testing the engine with a known good throttle or swapping the throttles side to side on a G-Drive engine and seeing if the problem moves are good ways to diagnose a stuck throttle.

DTC 2112 - Unable To Reach Higher TPS

| Step | Action | Value(s) | Yes | No |
|------|---|----------|---|---|
| 1 | Did you perform the On-Board (OBD) System Check? | - | Go to Step (2) | Go to OBD System Check Section |
| | Key ON, Engine OFF DST (Diagnostic Scan Tool) connected in DBW (Drive By Wire) test mode Depress ² foot pedal until the throttle command is 63%-68% Is the TPS voltage less than 2.0 volts? | | Go to Step (3) | Intermittent problem Go to Intermittent section |
| 3 | Key OFF Disconnect electronic throttle connector C017 Probe TPS 1 signal circuit pin 1 with test light connected to battery voltage Key ON | | Go to Step (4) | Go to Step (8) |
| 4 | Check throttle bore for foreign object Did you find a problem? | | Go to Step (5) | Go to Step (6) |
| 5 | Remove the foreign object Has the object been removed? | | Go to Step (11) | - |
| 6 | Check the electronic throttle connector terminals for damage corrosion or contamination Did you find a problem? | | Repair the circuit as necessary. Refer to Wiring Repairs in Engine Electrical. | Go to Step (7) |
| 7 | Replace throttle Is the replacement complete? | | Go to Step (11) | - |
| 8 | Key OFF Disconnect ECM wire harness connector C001 Using a DVOM check for continuity between throttle connector TPS 1 signal pin 1 and ECM TPS 1 signal pin 39 Do you have continuity between them? | | Go to Step (9) | Repair the circuit as necessary. Refer to Wiring Repairs in Engine Electrical. |
| 9 | Using a DVOM check for continuity between throttle connector TPS 1 signal pin 1 and engine ground Do you have continuity between them? | | Repair the shorted to ground circuit as necessary. Refer to Wiring Repairs in Engine Electrical. | Go to Step (10) |

| Step | Action | Value(s) | Yes | No |
|------|---|----------|-----------------|------------------------|
| 10 | Replace ECM Is the replacement complete? | | Go to Step (11) | - |
| 11 | Remove all test equipment except the DST. Connect any disconnected components, fuses, etc. Using the DST clear DTC information from the ECM. Turn the ignition OFF and wait 30 seconds. Start the engine and operate the vehicle to full operating temperature Observe the MIL Observe engine performance and drivability After operating the engine within the test parameters of DTC-2112 check for any stored codes. Does the engine operate normally with no stored codes? | | System OK | Go to OBD System Check |

DTC 2135 - TPS1/2 Simultaneous Voltages Out of Range

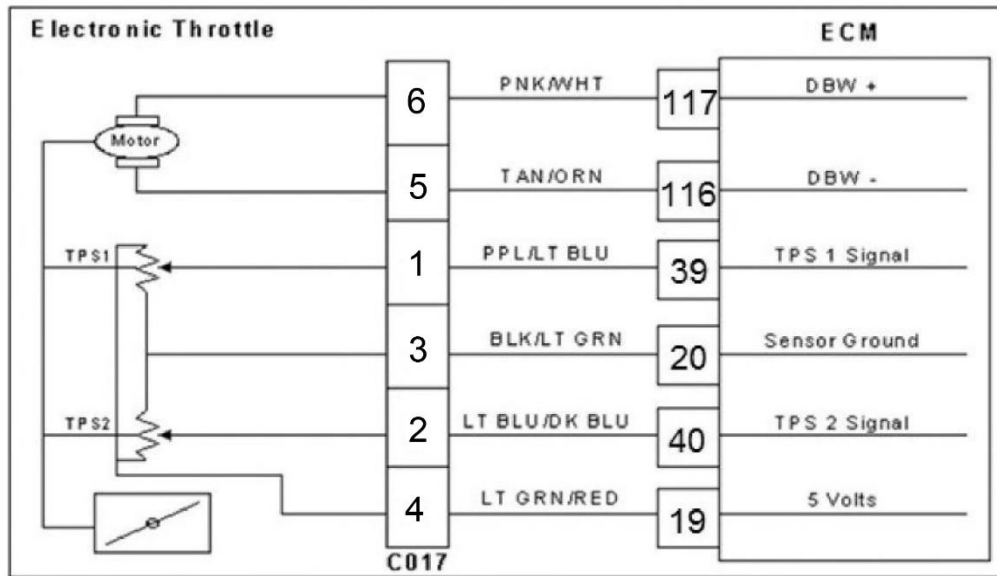

Conditions for Setting the DTC

- Check Condition: Key On, Engine running
- Fault Condition: TPS1 voltage is greater than 4.8V or less than 0.2V AND TPS2 voltage is greater than 4.8V or less than 0.2V
- MIL: ON during active fault
- Engine Shutdown

Fault Description

Dual throttle position sensors are used within the throttle that use variable resistors to determine signal voltage based on throttle plate position. TPS1 will read lower voltage when closed and TPS2 will read higher voltage when closed. The TPS1 and TPS2 percentages are calculated from these voltages. Although the voltages are different, the calculated values for the throttle position percentages should be very close to the same. The TPS values are used by the ECM to determine if the throttle is opening as commanded. The TPS is not serviceable and in the event of a failure the electronic throttle assembly must be replaced. This fault will set if there are simultaneous voltage out-of-range faults for both TPS 1 and TPS2.

Diagnostic Aids

- Troubleshoot according to TPS1 voltage out-of-range following DTC 122 and 123 procedures.
- Troubleshoot according to TPS2 voltage out-of-range following DTC 222 and 223 procedures.

DTC 2229 - BP High Pressure

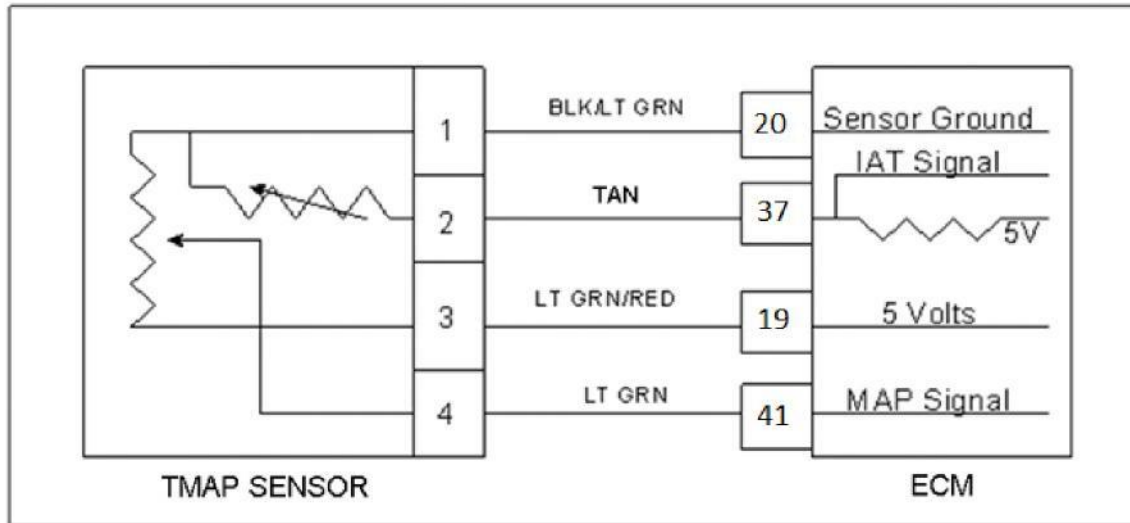

Conditions for Setting the DTC

- Check Condition: Key ON
- Fault Condition: BP greater than 16 psia
- MIL: ON for active fault
- Adaptive: Disabled

Circuit Description

The BP (Barometric Pressure) is estimated from the TMAP sensor. The barometric pressure value is used for fuel and airflow calculations. This fault sets in the event the BP value is out of the normal range.

DTC 2229 - BP High Pressure

| Step | Action | Value(s) | Yes | No |
|------|---|----------|----------------|---|
| 1 | Did you perform the On-Board (OBD) System Check? | - | Go to Step (2) | Go to OBD System Check Section |
| 2 | Key ON DST (Diagnostic Scan Tool) connected in System Data Mode Does DST display MAP pressure of 16 psia or greater? | | Go to Step (3) | Intermittent problem Go to Intermittent section |
| 3 | Replace TMAP sensor. Is the repair complete? | | Go to Step 4 | - |
| 4 | Remove all test equipment except the DST. Connect any disconnected components, fuses, etc. Using the DST clear DTC information from the ECM. Turn the ignition OFF and wait 30 seconds. Start the engine and operate the vehicle to full operating temperature Observe the MIL Observe engine performance and drivability After operating the engine within the test parameters of DTC-2229 check for any stored codes. Does the engine operate normally with no stored codes? | | System OK | Go to OBD System Check |

DTC 3031 - UEGO1 Heater Open/Ground Short

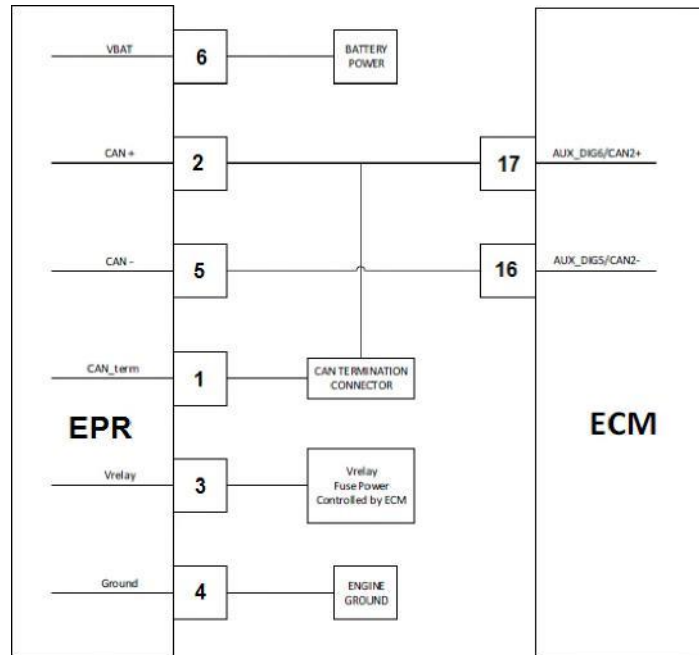

Conditions for Setting the DTC

- Check Condition: Key On
- Fault Condition: UEGO heater low-side feedback < 5% of Vbattery for 2 seconds and PWM duty cycle < 5%
- MIL: ON during active fault
- Closed Loop Disabled

Fault Description

A UEGO sensor measures the exhaust content across a wide-range of air-fuel ratios with a linear output proportional to lambda/equivalence ratio/air-fuel ratio. The sensor is heated with an internal resistive element that is supplied by the battery voltage and switched on/off by the ECM. The ECM will pull the heater control signal to ground when turning on the heater. The ECM monitors the heater control signal for a short to ground. If the control signal is not equal to Vbattery with the heater is turned off, then the circuit is not functioning properly. The UEGO heater circuit must always be functioning for proper emissions control.

This fault will set when the UEGO heater control signal does not achieve Vbattery when the heater is switched off. This may be caused by a bad heater element on the UEGO sensor, a break in the wire harness on the heater supply or control circuits, or fault within the ECM.

DTC 3031 - UEGO1 Heater Ooen/Ground Short

| Step | Action | Value(s) | Yes | No |
|------|---|---|----------------|--------------------------------|
| 1 | Did you perform the On-Board (OBD) System Check? | - | Go to Step (2) | Go to OBD System Check Section |
| 2 | Key Off, Engine Stopped Disconnect the harness from the UEGO Sensor and ECM With a DMM, measure the heater resistance (For Bosch sensor, measure the resistance between the white and grey lines connected to pins 3 and 4.) Normal resistance is approximately 2.5 ohms. | Is the resistance > 50 ohms? | Go to Step (3) | Go to Step (4) |
| 3 | UEGO heater element is bad Replace UEGO sensor | | | |
| 4 | Disconnect the harness from the ECM With DMM, check for continuity in the harness on the heater control signal (Test between Pin 3 on the UEGO sensor connector and Pin 75 on the ECM connector) | Does continuity exist (Is resistance < 5 ohms)? | Go to Step (5) | Go to Step (6) |
| 5 | Replace ECM | | | |
| 6 | Repair/Replace circuit in harness | | | |

DTC 3032 - UEGO1 Heater Short to Power

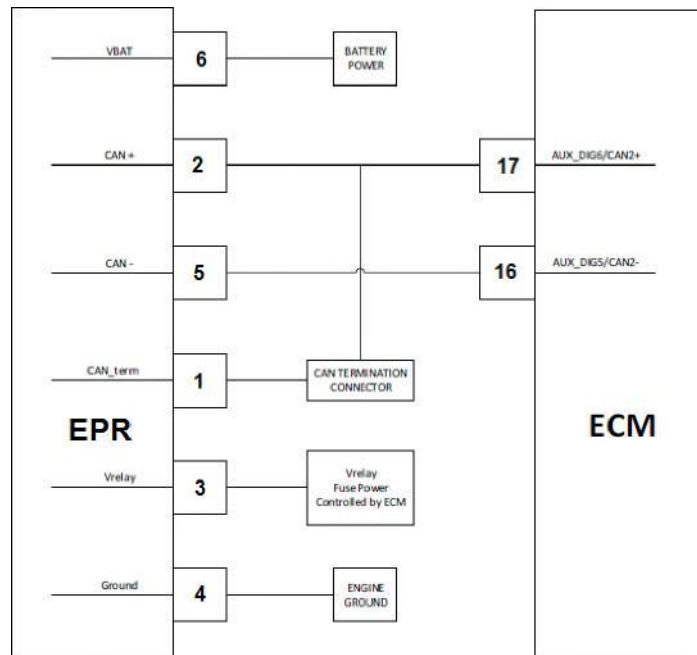

Conditions for Setting the DTC

- Check Condition: Key On
- Fault Condition: UEGO heater low-side feedback < 90% of Vbattery for 2 seconds and PWM duty cycle < 90%
- MIL: ON during active fault
- Closed Loop Disabled

Fault Description

A UEGO sensor measures the exhaust content across a wide-range of air-fuel ratios with a linear output proportional to lambda/equivalence ratio/air-fuel ratio. The sensor is heated with an internal resistive element that is supplied by the battery voltage and switched on/off by the ECM. The ECM will pull the heater control signal to ground when turning on the heater. The ECM monitors the heater control signal for a short to ground. If the control signal is not equal to Vbattery with the heater is turned off, then the circuit is not functioning properly. The UEGO heater circuit must always be functioning for proper emissions control.

This fault will set when the UEGO heater control signal does not achieve zero volts when the heater is switched on. This may be caused by an internal fault within the ECU.

DTC 3032 - UEGO1 Heater Short to Power

| Step | Action | Value(s) | Yes | No |
|------|---|-------------------------------|----------------|--------------------------------|
| 1 | Did you perform the On-Board (OBD) System Check? | - | Go to Step (2) | Go to OBD System Check Section |
| 2 | Key Off, Engine Stopped Disconnect the harness from the UEGO Sensor and ECM With a DMM, measure the heater resistance (For Bosch sensor, measure the resistance between the white and grey lines connected to pins 3 and 4.) Normal resistance is approximately 2.5 ohms. | Is the resistance < 0.5 ohms? | Go to Step (3) | Go to Step (4) |
| 3 | UEGO heater element is bad Replace UEGO sensor | | | |
| 4 | Disconnect the harness from the ECM Check the heater control signal (Test between Pin 3 and the UEGO sensor and Pin 75 of the ECM) for a short to Vbattery. NOTE: Perform this test using a DMM and check one pin at a time to the positive battery terminal | Is circuit shorted? | Go to Step (5) | Go to Step (6) |
| 5 | Replace ECM | | | |
| 6 | Repair/ short to Vbattery in harness | | | |

DTC 8901 - UEGO1 Internal Processor Fault

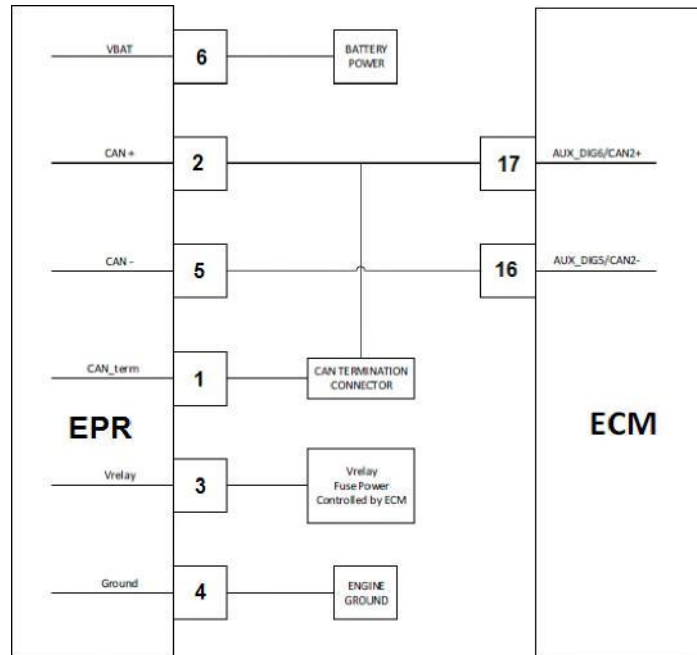

Conditions for Setting the DTC

- Check Condition: Key On
- MIL: ON during active fault
- Closed Loop and Adaptive Learn Disabled

Fault Description

A UEGO sensor measures the exhaust content across a wide-range of air-fuel ratios with a linear output proportional to lambda/equivalence ratio/air-fuel ratio. Internal to the ECM there is an application specific integrated circuit/controller that controls the sensor. The UEGO controller communicates internally within the ECM to the main microcontroller. The UEGO controller must always be functioning and communicating with the main microcontroller for proper emissions control.

This fault may be set if the power supplied to the ECM (alternator or battery power) is excessively noisy and exhibits low voltage dips or dropouts. It may also indicate an internal failure within the ECM. The fault will disable closed loop and adaptive learn for the remainder of the key cycle.

Diagnostic Aids

- Verify that the alternator is working properly and there is not excessive noise on the alternator output or battery power from other loads. This fault may occur if power repeatedly dips but does not completely drop out to zero.
- Verify the ECM ground is sufficient (clean and tight to the engine block).
- Swap ECM with a known good part, run engine for 10 minutes, and then retest.

DTC 8902 - UEGO1 Heater Supply High Voltage

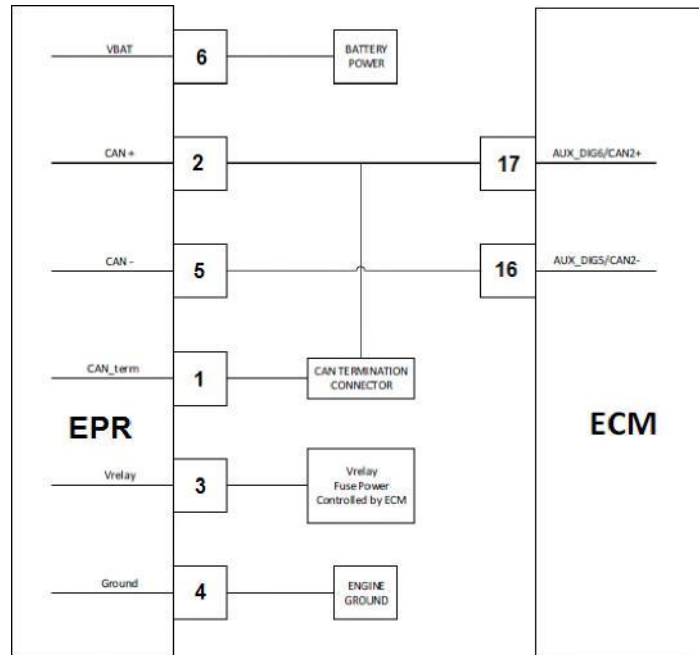

Conditions for Setting the DTC

- Check Condition: Key On
- Fault Condition: UEGO heater supply voltage > 32V
- MIL: ON during active fault
- Adaptive Disabled

Fault Description

A UEGO sensor measures the exhaust content across a wide-range of air-fuel ratios with a linear output proportional to lambda/equivalence ratio/air-fuel ratio. The sensor is heated with an internal resistive element that is supplied by the battery voltage and switched on/off by the ECM. The ECM will pull the heater control signal to ground when turning on the heater. The ECM monitors the heater control signal for a short to ground. If the control signal is not equal to Vbattery with the heater is turned off, then the circuit is not functioning properly. The UEGO heater circuit must always be functioning for proper emissions control.

This fault will set when the UEGO heater control signal is greater than 32V when the heater is switched on. This may be caused by an internal fault within the ECM. This fault will disable adaptive learn and light the MIL.

DTC 8902 - UEGO1 Heater Supply High Voltage

| Step | Action | Value(s) | Yes | No |
|------|---|-------------------------------|----------------|--------------------------------|
| 1 | Did you perform the On-Board (OBD) System Check? | - | Go to Step (2) | Go to OBD System Check Section |
| 2 | Key Off, Engine Stopped Disconnect the harness from the UEGO Sensor and ECM With a DMM, measure the heater resistance (For Bosch sensor, measure the resistance between the white and grey lines connected to pins 3 and 4.) Normal resistance is approximately 2.5 ohms. | Is the resistance < 0.5 ohms? | Go to Step (3) | Go to Step (4) |
| 3 | UEGO heater element has short Replace UEGO sensor | | | |
| 4 | Disconnect the harness from the ECM Check the heater control signal (Test between Pin 3 and the UEGO sensor and Pin 75 of the ECM) for a short to Vbattery. NOTE: Perform this test using a DMM and check one pin at a time to the positive battery terminal | Is circuit shorted? | Go to Step (5) | Go to Step (6) |
| 5 | Replace ECM | | | |
| 6 | Repair/ short to Vbattery in harness | | | |

DTC 8904 - UEGO1 Internal Supply Voltage Low

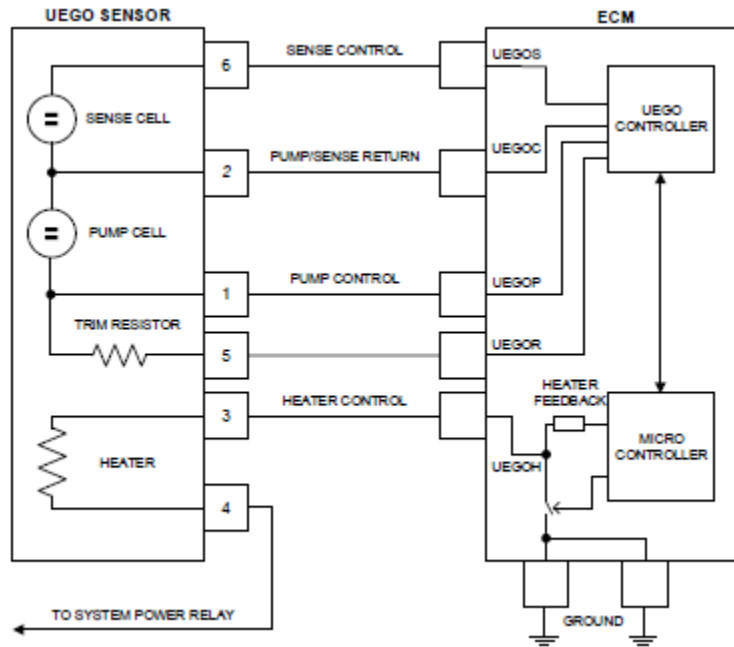

Conditions for Setting the DTC

- Check Condition: Key On
- Fault Condition: UEGO internal supply voltage is low
- MIL: ON during active fault
- Closed Loop Disabled

Fault Description

A UEGO sensor measures the exhaust content across a wide-range of air-fuel ratios with a linear output proportional to lambda/equivalence ratio/air-fuel ratio.

The ECM examines the sensors in order (1-4). The first pre-catalyst sensor found will be associated with Bank 1. The second pre-catalyst sensor will be associated with Bank 2 or will be used for averaging. The first post-catalyst sensor will be associated with Bank 1. The second post-catalyst sensor will be associated with Bank 2.

This fault sets whenever the UEGO processing circuitry supply voltage is too low for normal operation, and the Vbat or Vrelay low-pass filtered voltage supplying power to the UEGO circuitry is $> 9.0V$. Typically, this fault only sets when the power is noisy due to a failed alternator or another supply voltage problem and the ECM is unable to monitor the noise via the low-passed supply feedback.

Diagnostic Aids

- Inspect alternator and repair/replace as needed.
- Troubleshoot supply voltage source; repair/replace as needed
- Replace UEGO sensor and re-test
- Replace ECM and re-test

DTC 8910 - UEGO1 Sense Cell Voltage High

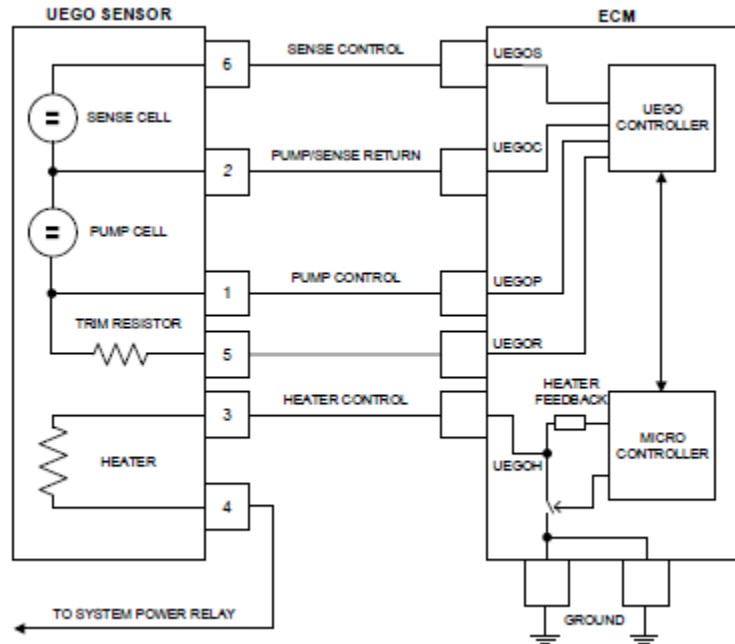

Conditions for Setting the DTC

- Check Condition: Engine Running/Stopped Checked (user-defined in calibration)
- Fault Condition: Voltage feedback from the UEGO sensor sense cell signal is high.
- MIL: ON during active fault
- Closed Loop Disabled

Fault Description

A UEGO sensor measures the exhaust content across a wide-range of air-fuel ratios with a linear output proportional to lambda/equivalence ratio/air-fuel ratio.

UEGO sensors comprise of both a pump cell and a sense cell.

If the pump cell is at its drive limit it means it is no longer in control.

This fault is only applicable to non-smart NGK UEGO sensors.

The ECM examines the sensors in order (1-4). The first pre-catalyst sensor found will be associated with Bank 1. The second pre-catalyst sensor will be associated with Bank 2 or will be used for averaging. The first post-catalyst sensor will be associated with Bank 1. The second post-catalyst sensor will be associated with Bank 2.

This fault is triggered when the ECM detects a higher than expected voltage feedback from the sense cell, which indicates that the sensor is not operating correctly.

It may be a result of a faulty sensor, poor harness, or ECM failure.

DTC 8910 - UEGO1 Sense Cell Voltage High

| Step | Action | Value(s) | Yes | No |
|------|--|-------------------------|----------------|--------------------------------|
| 1 | Did you perform the On-Board (OBD) System Check? | - | Go to Step (2) | Go to OBD System Check Section |
| 2 | Key OFF Engine Stopped Disconnect the harness from the UEGO sensor and ECM. Check the sense control signal (test between Pin 6 of the UEGO sensor and the ECM pin assigned to UEGOS) for a short to Vbattery. NOTE: Perform this test using a DMM and check one pin at a time to battery plus | Is the circuit shorted? | Go to Step (3) | Go to Step (4) |
| 3 | Repair short to Vbattery in harness | | | - |
| 4 | Faulty UEGO Sensor or Faulty ECM | | | |

DTC 8914 - UEGO1 Sense Cell Slow to Warm Up

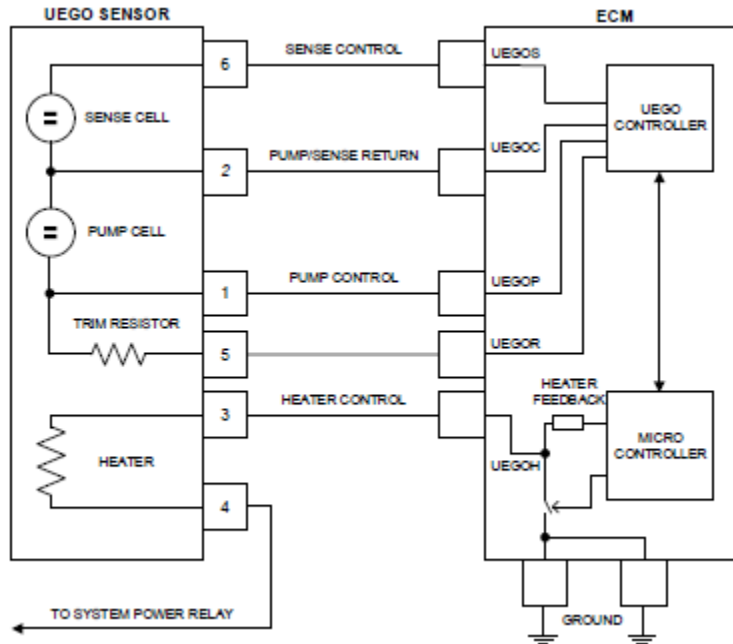

Conditions for Setting the DTC

- Check Condition: Engine Running/Stopped Checked (user-defined in calibration)
- Fault Condition: Internal fault message communicated to ECM over CAN
- MIL: ON during active fault
- Closed Loop Disabled

Fault Description

A UEGO sensor measures the exhaust content across a wide-range of air-fuel ratios with a linear output proportional to lambda/equivalence ratio/air-fuel ratio.

UEGO sensors comprise of both a pump cell and a sense cell.

If the pump cell is at its drive limit it means it is no longer in control.

This fault is only applicable to non-smart NGK UEGO sensors.

The ECM examines the sensors in order (1-4). The first pre-catalyst sensor found will be associated with Bank 1. The second pre-catalyst sensor will be associated with Bank 2 or will be used for averaging. The first post-catalyst sensor will be associated with Bank 1. The second post-catalyst sensor will be associated with Bank 2.

- Poor harness connections
- Faulty sensor

NOTE: The UEGO sense cell slow to warm up faults are currently only "set" when running the Closed-Loop test from the Tests page in EDIS. As such these will not complete during normal operation of the engine.

Diagnostic Aids:

- Check harness (post-control box harness, sensor side) for poor connections

- Replace sensor with known good unit and re-test

DTC 8916 - UEGO1 Sense Cell Impedance High

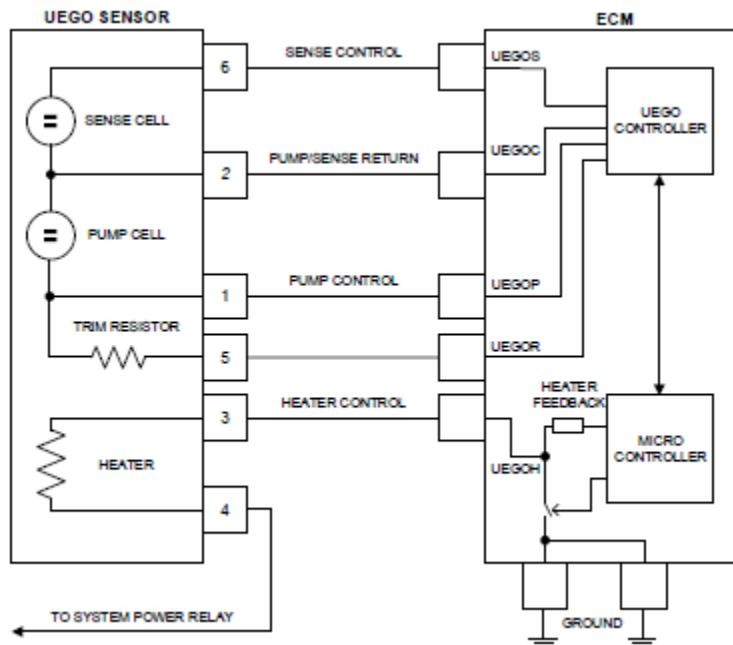

Conditions for Setting the DTC

- Check Condition: Engine Running/Stopped Checked (user-defined in calibration)
- Fault Condition: UEGO sense cell impedance is high
- MIL: ON during active fault
- Closed Loop Disabled

Fault Description

A UEGO sensor measures the exhaust content across a wide-range of air-fuel ratios with a linear output proportional to lambda/equivalence ratio/air-fuel ratio. Internal to the ECM there is an application specific integrated circuit/controller that controls the sensor. The UEGO controller communicates internally within the ECM to the main microcontroller. The UEGO controller must always be functioning and communicating with the main microcontroller for proper emissions control.

The ECM examines the sensors in order (1-4). The first pre-catalyst sensor found will be associated with Bank 1. The second pre-catalyst sensor will be associated with Bank 2 or will be used for averaging. The first post-catalyst sensor will be associated with Bank 1. The second post-catalyst sensor will be associated with Bank 2.

For non-smart CAN based UEGO sensors this fault is triggered when the impedance of sense cell is too high, which indicates that the sensor has not warmed up correctly.

It may be a result of cracked sensor, poor harness or ECM failure.

For smart CAN based sensors, the sensor self-diagnoses a heater failure and transmits the diagnostic to the ECM

Diagnostic Aids:

- Check harness (post-control box, sensor side) for poor connections.

- Replace sensor with known good unit and re-test.

DTC 8920 - UEGO1 Internal Supply Voltage Low

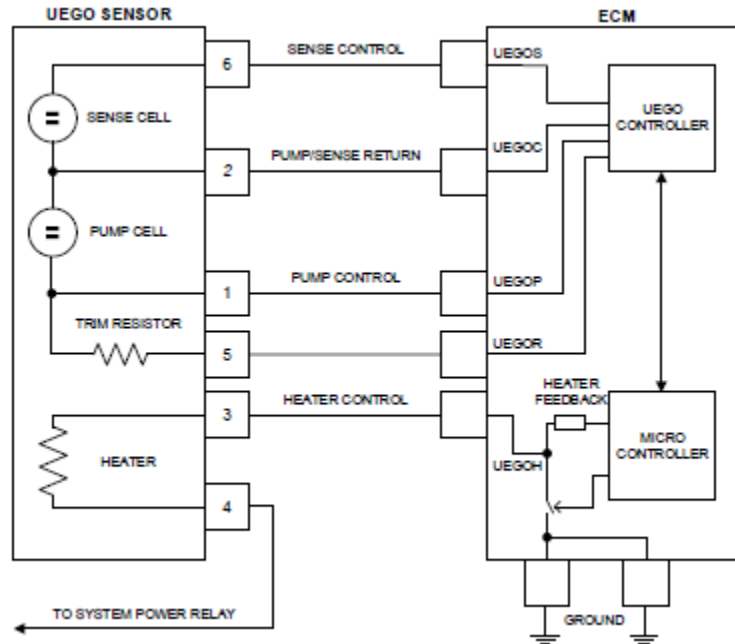

Conditions for Setting the DTC

- Check Condition: Engine Running/Stopped Checked (user-defined in calibration)
- Fault Condition: UEGO internal supply voltage is low
- MIL: ON during active fault
- Closed Loop Disabled

Fault Description

A UEGO sensor measures the exhaust content across a wide-range of air-fuel ratios with a linear output proportional to lambda/equivalence ratio/air-fuel ratio.

The ECM examines the sensors in order (1-4). The first pre-catalyst sensor found will be associated with Bank 1. The second pre-catalyst sensor will be associated with Bank 2 or will be used for averaging. The first post-catalyst sensor will be associated with Bank 1. The second post-catalyst sensor will be associated with Bank 2.

This fault sets whenever the UEGO processing circuitry supply voltage is too low for normal operation, and the Vbat or Vrelay low-pass filtered voltage supplying power to the UEGO circuitry is > 9.0V. Typically, this fault only sets when the power is noisy due to a failed alternator or another supply voltage problem and the ECM is unable to monitor the noise via the low-passed supply feedback

Diagnostic Aids:

- Inspect alternator and repair/replace as needed.
- Troubleshoot supply voltage source; repair/replace as needed
- Replace UEGO sensor and re-test
- Replace ECM and re-test

Definitions

Air Valve Vacuum (AVV): The vacuum signal taken from below the air valve assembly and above the throttle butterfly valve.

ADP: Adaptive Digital Processor.

Air/Fuel Ratio: The amount or balance of air and fuel in the air fuel mixture that enters the engine.

Analog Voltmeter: A meter that uses a mechanical needle to point to a value on a scale of numbers. It is usually of the low impedance type and used to measure voltage and resistance.

Aromatics: Pertaining to or containing the six-carbon ring characteristic of the benzene series. Found in many petroleum distillates.

Backfire: Combustion of the air/fuel mixture in the intake or exhaust manifolds. A backfire can occur if the intake or exhaust valves are open when there is a mis-timed ignition spark.

Benzene: An aromatic (C₆H₆). Sometimes blended with gasoline to improve anti-knock value. Benzene is toxic and suspected of causing cancer.

Bi-Fueled: A vehicle equipped to run on two fuels.

Blow-By: Gases formed by the combustion of fuel and air, which ordinarily should exert pressure only against the piston crown and first compression ring. When rings do not seal, these gases escape or "blow by" the side of the piston into the crankcase.

BTU: British Thermal Unit. A measurement of the amount of heat required to raise the temperature of 1lb. of water 1 degree F.

Butane: An odorless, colorless gas, C₅H₁₀ found in natural gas and petroleum. One of the five LP gases.

CAFE: Corporate Average Fuel Economy.

CARB: California Air Resources Board.

Carbon Monoxide (CO): A chemical compound of a highly toxic gas that is both odorless and colorless.

Carburetor: An apparatus for supplying an internal-combustion engine a mixture of vaporized fuel and air.

Cathode Ray Tube: A vacuum tube in which cathode rays usually in the form of a slender beam are projected on a fluorescent screen and produce a luminous spot.

Circuit: A path of conductors through which electricity flows.

Closed Loop Operation: Applies to systems utilizing an oxygen sensor. In this mode of operation, the system uses oxygen sensor information to determine air/fuel ratio. Adjustments are made accordingly and checked by comparing the new oxygen sensor to previous signals. No stored information is used.

CNG: Compressed Natural Gas.

CKP: Crankshaft Position Sensor

CMP: Camshaft Position Sensor

Conductor: A material, normally metallic, that permits easy passage of electricity.

Contaminants: Impurities or foreign material present in fuel.

Control Module: One of several informal names for a solid state microcomputer which monitors engine conditions and controls certain engine functions; i.e. air/fuel ratio, injection and ignition time, etc. The formal name and the one used throughout this manual is ECM, or Engine Control Module.

Converter: A LPG fuel system component containing varying stages of fuel pressure regulation combined with a vaporizer.

Cryogen: A refrigerant used to obtain very low temperatures.

Current: The volume or flow of electrons through a conductor. Measured in amperes or amps. **DBW:** Drive By Wire

Dedicated Fuel System: A motor fuel system designed to operate on only one fuel type.

Diaphragm: A thin, flexible membrane that separates two chambers. When the pressure in one chamber is lower than in the other chamber, the diaphragm will move toward the side with the low pressure.

Diaphragm Port: The external port located at the fuel inlet assembly and connected to the vacuum chamber above the air valve diaphragm.

DLC: Data Link Connector.

DTC: Diagnostic Trouble Code

DST: Diagnostic Scan Tool.

DVOM: Digital Volt/ohm Meter. A meter that uses a numerical display in place of a gauge and is usually of the high impedance type.

ECT: Engine Coolant Temperature.

ECM: Electronic Control Module

ECOM: A DLC cable supporting CAN and serial communication with a NGE/EControls ECM.

EFI: Electronic Fuel Injection. A fuel injection system, which uses a microcomputer (ECM) to determine and control the amount of fuel, required by, and injected into, a particular engine.

EGO: Exhaust Gas Oxygen, used to describe a sensor. Also known as "HEGO" (Heat Exhaust Gas Oxygen) sensor, "O₂" or "Oxygen sensor.

EGR: Exhaust Gas Recirculation.

EPA: Environmental Protection Agency: A regulating agency of the Federal government which, among other duties, establishes and enforces automotive emissions standards.

Ethanol: Grain alcohol (C_2H_5OH), generally produced by fermenting starch or sugar.

Evaporative Emissions Controls: An automotive emission control system designed to reduce hydrocarbon emissions by trapping evaporated fuel vapors from the fuel system.

Excess Flow Valve: A check valve that is caused to close by the fuel when the flow exceeds a predetermined rate.

FTV: Fuel Trim Valve.

FFV: Flexible Fuel Vehicle.

Firing Line: The portion of an oscilloscope pattern that represents the total amount of voltage being expended through the secondary circuit.

FMVSS: Federal Motor Vehicle Safety Standards.

FPP: Foot Pedal Position Sensor

Fuel Injector: a spring loaded, electromagnetic valve which delivers fuel into the intake manifold, in response to an electrical input from the control module.

Fuel Lock: A solenoid-controlled valve located in the fuel line to stop the flow when the engine stops or the ignition switch is off.

Gasohol: 10 percent ethanol, 90 percent gasoline. Often referred to as E-10.

Gasoline: A motor vehicle fuel that is a complex blend of hydrocarbons and additives. Typical octane level is 89.

GCP: Spectrum III (90-pin) ECM.

Greenhouse Effect: A scientific theory suggesting that carbon dioxide from the burning of fossil fuels is causing the atmosphere to trap heat and cause global warming.

HC: Hydrocarbon. An organic chemical compound.

HD 10: A fuel of not less than 80% liquid volume propane and not more than 10% liquid volume propylene.

HD 5: A fuel of not less than 90% liquid volume propane and not more than 5% liquid volume propylene.

HDV: Heavy Duty Vehicle.

Heavy Ends: A term used to describe the buildup of wax-like impurities that fall out of LPG when vaporized.

HEGO: Heated Exhaust Gas Oxygen, used to describe a sensor. Also known as "EGO" (Exhaust Gas Oxygen sensor), " O_2 " or "Oxygen sensor).

Hg: Chemical symbol for the element mercury. Used in reference to a measure of vacuum (inches of Hg).

Histogram: The graphical version of a table which shows what proportion of values fall into specific categories over a specific period of time.

Hydrocarbon: A chemical compound made up of hydrogen and carbon (HC). Gasoline and almost all other fuels are hydrocarbons.

Hydrostatic Relief Valve: A pressure relief device installed in the liquid LPG hose on a LPG fuel system.

IAT: Intake Air Temperature

Ideal Mixture: The air/fuel ratio at which the best compromise of engine performance to exhaust emissions is obtained. Typically 14.7:1.

Ignition Reserve: The difference between available voltage and the required voltage.

ILEV: Inherently Low Emission Vehicle.

Impedance: A form of opposition of AC electrical current flow (resistance) measured in ohms.

Insulation: A nonconductive material used to cover wires in electrical circuits to prevent the leakage of electricity and to protect the wire from corrosion.

Intercept: An electrical term for a type of splice where the original circuit is interrupted and redirected through another circuit.

Knock: Sound produced when an engine's air/fuel mixture is ignited by something other than the spark plug, such as a hot spot in the combustion chamber. Also caused by a fuel with an octane rating that is too low and/or incorrect ignition timing. Also called detonation or ping.

Lambda Sensor: A feedback device, usually located in the exhaust manifold, which detects the amount of oxygen present in exhaust gases in relation to the surrounding atmosphere. (See HEGO).

LDV: Light Duty Vehicle.

Lean Mixture: An air to fuel ratio above the stoichiometric ratio; too much air.

LEV: Low Emission Vehicle.

Limp-in or Limp Home: A mode where the ECM or a component has failed, but the vehicle remains operational although the engine may operate minimally. This term may also describe the drivability characteristics of a failed computer system.

Liquid Petroleum Gas (LPG): A fuel commonly known as propane consisting mostly of propane (C_3H_8), derived from the liquid components of natural gas stripped out before the gas enters the pipeline, and the lightest hydrocarbons produced during petroleum refining. Octane level of LPG is 107.

LPG: Liquefied Petroleum Gas.

M85: A blend of gasoline and methanol consisting of 85% methanol and 15% gasoline.

Measurements of Pressure: 1 PSI=2.06" Hg (mercury) = 27.72" H₂O (water column). At sea level atmospheric pressure is 29.92" Hg.

Methanol: Known as wood alcohol (CH₃OH), a light, volatile, flammable alcohol commonly made from natural gas.

MIL: Malfunction Indicator Lamp.

Misfire: Failure of the air/fuel mixture to ignite during the power stroke.

Mixer: Fuel introduction device that does not include a throttle plate.

MFI: Multiport Fuel Injection. A fuel injection system that uses one injector per cylinder mounted on the engine to spray fuel near the intake valve area of combustion chamber.

MSV: Manual Shut-Off Valve. Refers to the manually operated valve on the LPG tank.

MTBE: Methyl Tertiary Butyl Ether. Oxygenate add to gasoline to reduce harmful emissions and to improve the octane rating.

Multi-fuel System: A motor fuel system designed to operate on two different fuels, such as LPG and gasoline.

Natural Gas: A gas formed naturally from buried organic material, composed of a mixture of hydrocarbons, with methane (CH₄) being the dominant component.

NGV: Natural Gas Vehicle.

NOX: See Oxides of Nitrogen.

OBD: On Board Diagnostic

Octane Rating: The measurement of the antiknock value of a motor fuel.

OEM: Original Equipment Manufacturer, the vehicle manufacturer.

Open-Loop: An operational mode during which control module memory information is used to determine air/fuel ratio, injection timing, etc., as opposed to actual oxygen sensor input.

Orifice: A port or passage with a calibrated opening designed to control or limit the amount of flow through it.

Oscilloscope: An instrument that converts voltage and frequency readings into traces on a cathode ray tube (also see Cathode Ray Tube).

Oxides of Nitrogen: Chemical compounds of nitrogen bonded to various amounts of oxygen (NOX). A chief smog forming-agent.

Oxygen Sensor: An automotive fuel system that produces a signal in accordance with the oxygen content of the exhaust gas. (See Lambda Sensor).

Oxygenate: Oxygenates (such as MTBE, ethanol

and methanol) added to gasoline to increase the oxygen content and therefore reduce exhaust emissions.

Ozone: A radical oxygen molecule (O₃) that is found in the upper atmosphere and filters out ultraviolet radiation from the sun. Ground level ozone is formed by NOX, during the formation of photochemical smog.

Particulates: Microscopic pieces of solid or liquid substances such as lead and carbon that are discharged into the atmosphere by internal combustion engines.

Positive Crankcase Ventilation (PCV): An automotive emission control system designed to reduce hydrocarbon emissions by routing crankcase fumes into the intake manifold rather than to the atmosphere.

Power Derate: A mode of reduced engine power output for the purposes of protecting engine components during a failure or malfunction.

Pressure Differential: The differential between atmospheric pressure and intake manifold (referred to as vacuum) pressure.

Pressure Regulator: A device to control the pressure of fuel delivered to the fuel injector(s).

Primary Circuit: The low-voltage or input side of the ignition coil.

Propane: An odorless and colorless gas, C₃H₈, found in natural gas and petroleum.

PSIa: pounds per square inch absolute

PTV: Pressure Trim Valve

Reactivity: Refers to the tendency of an HC in the presence of NOX and sunlight to cause a smog-forming reaction. The lighter the HC, the lower reactivity tends to be.

Regulator: An assembly used to reduce and control the pressure of a liquid or vapor.

Resistance: The opposition to the flow of current in an electrical circuit. Measured in ohms.

Rest Pressure: Fuel pressure maintained within the system after engine shutdown.

Rich Mixture: An air to fuel ratio below the stoichiometric ratio; too much fuel.

SAE: Society of Automotive Engineers.

Secondary Circuit: The high-voltage output side of the ignition coil.

SEFI or SFI: Sequential Electronic Fuel Injection or Sequential Fuel Injection.

Sensors: Devices that provide the control module with engine information as needed to properly control engine function.

Spark Line: The portion of an oscilloscope pattern that represents the time during which the air/fuel mixture is being burned in the combustion chamber.

Splice: An electrical term for the joining of two or more conductors at a single point.

Stoichiometric Ratio: An ideal fuel/air ratio for combustion in which all of the fuel and most of the oxygen will be burned.

Sulfur Oxides: Chemical compounds where sulfur is bonded to oxygen produced by the combustion of gasoline or any other fuel that contains sulfur. As sulfur oxides combine with water in the atmosphere to form sulfuric acid.

System Pressure: The fuel pressure maintained in the system during normal engine operation.

Tap: An electrical term for a type of splice where the original circuit is not interrupted.

TBI: Throttle Body Injection. Any of several injection systems that have the fuel injector(s) mounted in a centrally located throttle body.

Throttle Body: Controls engine RPM by adjusting the engine manifold vacuum to the mixer. Consists of a housing shaft, throttle liner and butterfly valve.

TLEV: Transitional Low Emission Vehicle.

TMAP: Combined Air Inlet and Manifold Pressure Sensor.

Toluene: A liquid aromatic hydrocarbon C_7H_8 . **TPS:** Throttle Position Sensor.

TSB: Technical Service Bulletin.

ULEV: Ultra Low Emission Vehicle.

USB: Universal Serial Bus. A plug or interface supplied on most personal computers.

Vaporization: A process in which liquid changes states into gas.

Variable Frequency Driver (VFD): Allow electrical loads from motors to be applied gradually.

Venturi Air Valve Vacuum (VAVV): An amplified air valve vacuum signal coming from the venturi area of the mixer, directly exposed to airflow before the addition of vaporized LPG.

Volt/ohmmeter (VOM): A combination meter used to measure voltage and resistance in an electrical circuit. Available in both analog and digital types. May also referred to as AVOM and DVOM.

Voltage: The electrical pressure that causes current to flow in a circuit. Measured in volts.

Voltage Drop: A lowering of the voltage in a circuit when resistance or electrical load is added.

Voltmeter: A meter that uses a needle to point to a value on a scale of numbers usually of the low impedance type; used to measure voltage and resistance.

VSS: Vehicle Speed Sensor

Xylene: $C_6H_4(CH_3)_2$. Any of three toxic, flammable, and oily isomeric aromatic hydrocarbons that are dimethyl homologues of benzene and usually obtained from petroleum or natural gas distillates.

ZEV: Zero Emission Vehicle.

Connecting to Each ECM

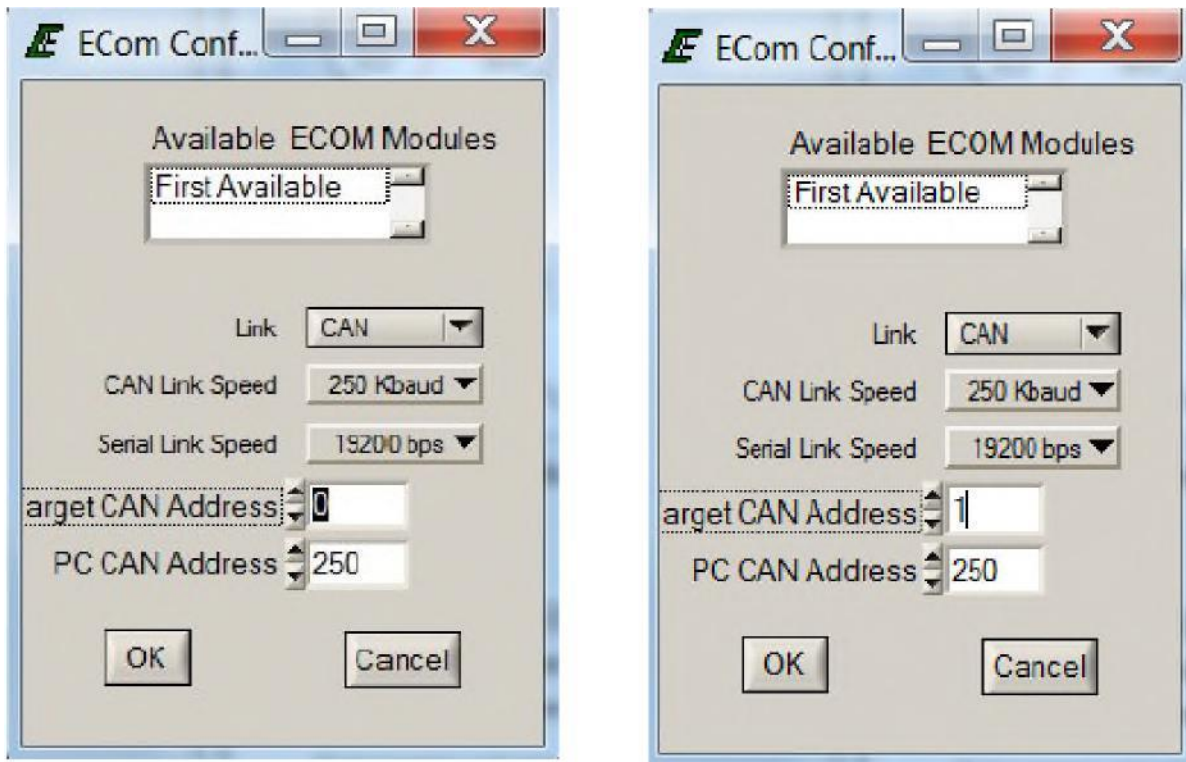

NOTE:

- ECOM cable and PC with the latest revision of 4G software is needed before performing the below instructions.
- Steps 1-8 should be repeated if the secondary 4G display is closed while the engine is off. At no time should 4G display be left communicating with the primary ECM on its own.
- You can leave the display open while disconnecting the ECOM from the engine and reconnecting.
 1. Connect ONE ECOM cable to the diagnostic port on the engine harness.

NOTE:

These engines only require the use of one ECOM unlike the previous GCP versions that required one per bank.

2. Start the engine.
3. Open the 4G display and verify it has connected in the to left corner.
4. Select "COMM PORT", then "Configure ECOM".
5. An ECOM configuration window will appear (Image above). For "Target CAN Address", change the "0" to a "1", then select "OK".
6. Disconnect the ECOM USB connection from your computer and reconnect. Verify secondary bank connectivity by going to the Marine page and verify secondary communications.
7. Launch a second version of 4G display to connect to the primary, verify both screens are connected.
8. Monitor the "CUST SOFTWARE NAME/NUMBER". The secondary bank will be one digit higher than the primary

MFG Valve Operation & Diagnostics

MFG Valve Overview

The 40L and 53L engines are equipped with Mass Flow Gas valves (“MFG”). This valve replaces the traditional EPR and mixer fuel systems found on smaller engines. The MFG contains a brushless motor that controls the movement of a throttle shaft within the MFG. Fuel flow is controlled by changing the position of the throttle shaft, allowing accurate and consistent fuel mass flow rates.

After fuel flow is controlled by the MFG, the controlled gaseous supply flow is directed to the fuel-air mixer where it is mixed with air to produce a combustible fuel-air mix. The fuel-air mixture is then compressed via the turbocharger and cooled via the CAC.

The flow of the fuel-air mixture is controlled by separate throttles (one per bank) which are located downstream of the MFG, fuel mixer, and Turbo/CAC. You can see this as a visual representation on the last page of this document as image 1.

Basic Information

One MFG is installed per engine bank (1 Primary side & 1 Secondary side)

The MFG is directional, there is an arrow cast into the housing indicating flow direction

Communicates with the ECM via CAN

MFG contains 3 pressure sensors and temperature sensor Upstream Absolute Pressure Sensor

Downstream Absolute Pressure Sensor

Delta Pressure Sensor

Fuel Requirements

See PSI publication 56100051 “MFG Fuel System Setup Guidelines” for detailed requirements and information.

- Minimum 3” NPT regulator with at least 5psi at the regulator inlet
- 20 to 30 inches of water column (inH₂O) at the MFG inlet while engine is at full operating load
- Piping between regulator outlet and the lockoff inlets should be at least 3” NPT

Important Diagnostic Variables

Anytime you are running, commissioning, or diagnosing an MFG equipped engine, PSI recommends using 4G Display and our custom PSI HD plot file template. This plot file template will allow you to record many variables in 4G Display which may be useful in diagnostics. The PSI HD plot file template can be downloaded from the PSI cloud-based support portal or by reaching out to PSI technical support at www.psiengines.com/service in the support section.

Important Diagnostic Variables

The maximum MFG Throttle Actual Percent (MFG_TPS_act_pct) is limited by the calibration in the engine ECM. Early engines may have the maximum MFG TPS % set to 89% whereas the latest calibrations are set to 75% maximum MFG TPS %.

Pressure Measurement Units: The MFG reports data in PSI (pounds per square inch). The upstream and downstream pressure sensors report in PSIA (pounds per square inch absolute), which includes the atmospheric pressure. 4G Display shows MFG Pressure as PSIA.

Adjusting for Atmospheric Pressure: Since the sensors use PSIA, adjustments need to be made to account for the atmospheric pressure to ensure that the pressure supplied to the engine is correct (20-30 IWC). This corrected pressure is what we refer to as gauge pressure, in this case, measured in IWC (inches of water column).

Correct Pressure Range for Engines: The engine requires a fuel pressure in the range of 20-30 IWC (gauge pressure). This is roughly equivalent to 1 PSI (since 1 PSI = 27 IWC).

The upstream and downstream numbers in 4G Display will stay in the 14-15 psi range at sea level even when making large pressure changes.

An easy method to convert MFG inlet pressure is below

(MFG Upstream Pressure – Barometric Pressure) X 27 = MFG Inlet Fuel Pressure in Inches of Water Column

Example Calculations

Excessive Fuel Pressure - - - - -

MFG_USPress = 16.76
BP = 10.8
 $(16.76 - 10.8) \times 27 = 158.49$ inWC

Correct Fuel Pressure - - - - -

MFG_USPress = 12.16
BP = 10.9
 $(12.16 - 10.9) \times 27 = 34.02$ inWC

The diagram illustrates the conversion of MFG upstream pressure to gauge pressure. It features two data tables, each with a 'Cursor 1' indicator. The first table shows values for Time (22.548), rpm (137.000), BP (10.848), MFG_USPress (16.763), and MFG_DSPress (10.805). A red dashed arrow points from the 'Excessive Fuel Pressure' calculation to the MFG_USPress value of 16.763. The second table shows values for Time (334.254), rpm (1803.000), BP (10.949), MFG_USPress (12.165), and MFG_DPPress (1.167). A green dashed arrow points from the 'Correct Fuel Pressure' calculation to the MFG_USPress value of 12.165.

| Cursor 1 | |
|-------------|---------|
| Time | 22.548 |
| rpm | 137.000 |
| BP | 10.848 |
| MFG_USPress | 16.763 |
| MFG_DSPress | 10.805 |

| Cursor 1 | |
|-------------|----------|
| Time | 334.254 |
| rpm | 1803.000 |
| BP | 10.949 |
| MFG_USPress | 12.165 |
| MFG_DPPress | 1.167 |

Diagnostic Tips

Fuel Delivery Issues (Volume or Pressure)

Monitor the MFG_DPPress (MFG differential pressure across the device) and MFG_TPS_act_pct (MFG actual throttle position). An ideal differential pressure reading on a plot file is a above 0.5 (rule of thumb). If the delta pressure goes below 0.25, throttle position could spike to the maximum value allowed in the calibration (either 89% or 75%). When looking at the plot file you can see the MFG TPS % (Pink Line) has a clear step change high and then a saturation/flatline. This indicates the fuel flow is not adequate and the system is losing control.

Notice how as engine load increases, the upstream pressure decreases (Blue Line). The delta pressure eventually drops below 0.5psi and the MFG throttle percentage (Pink Line) increases to the max position. This is an example of low fuel volume and pressure being delivered to the regulator and subsequently the MFG.

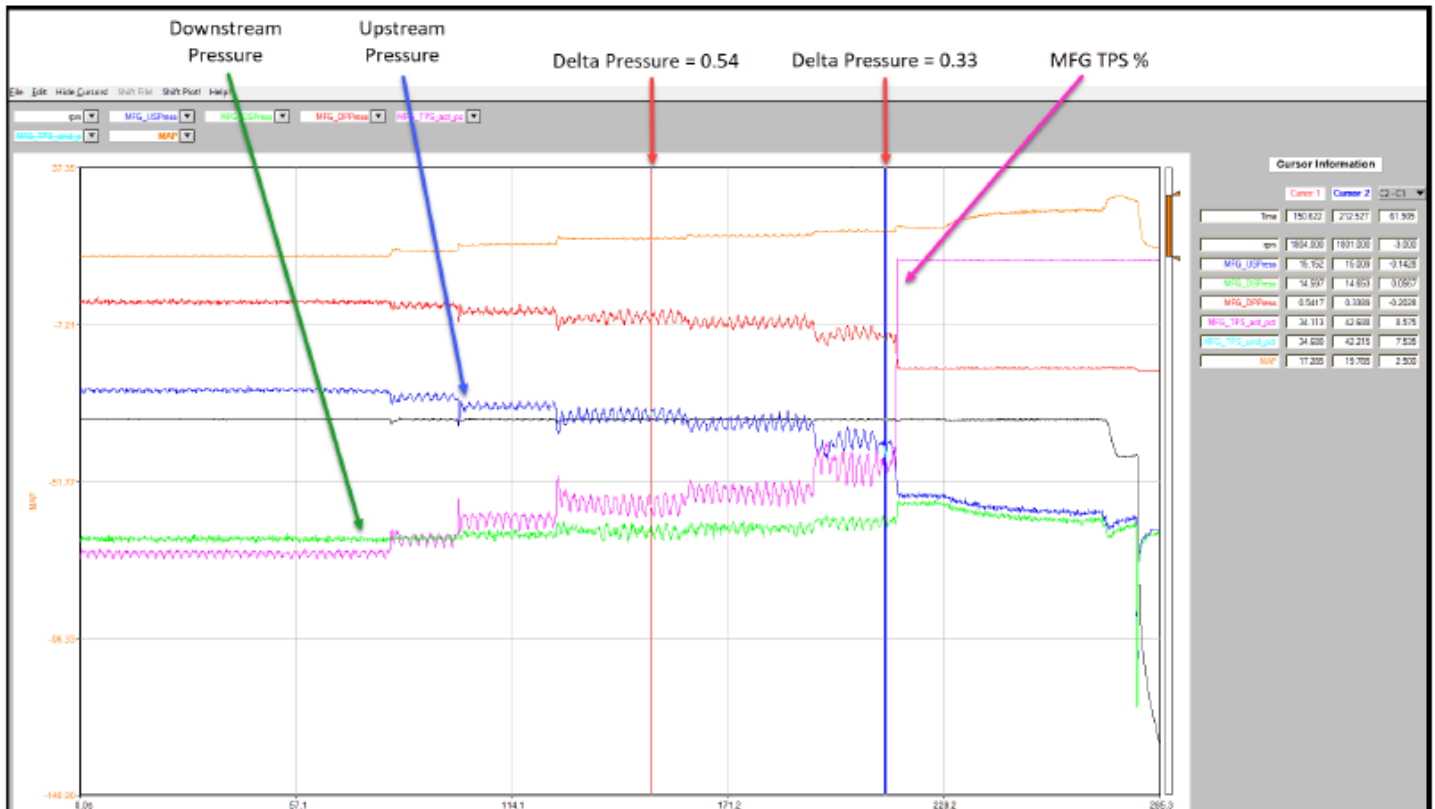

Compare the prior plot file data to the example shown below, which is a good test run to full load.

1. Delta Pressure never drops below 0.50
2. MFG TPS is steady at 36% during full load

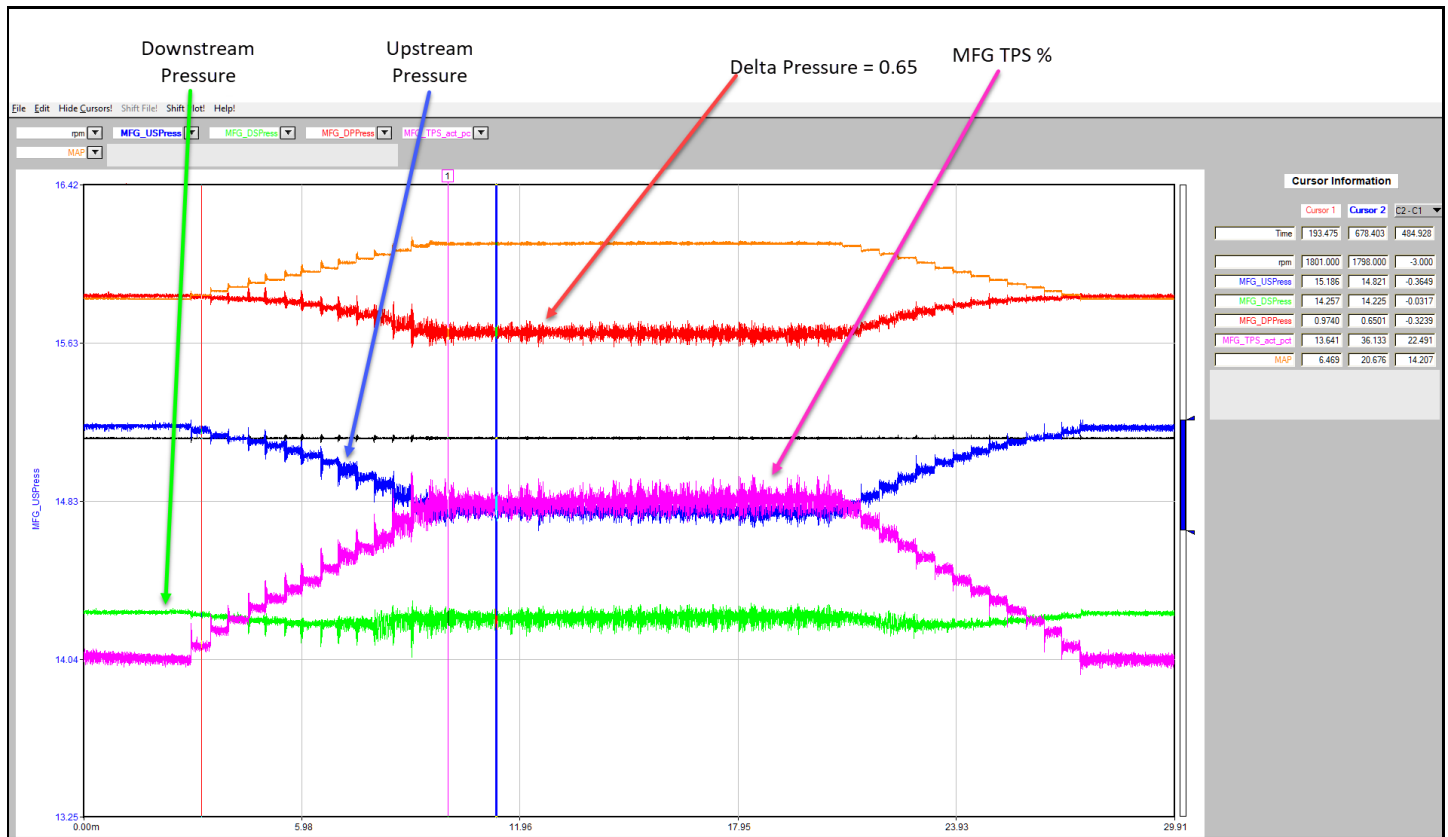

Additional Information on Pressure Conversion

The simple chart below shows an estimated conversion of inches of water column (IWC) to PSIA, which is what is displayed in 4G Display.

If barometric pressure is 14.7 psi

Fuel pressure 20 IWC → 15.4 psi

Fuel pressure 30 IWC → 15.8 psi

Fuel pressure 40 IWC → 16.2 psi

If barometric pressure is 12 psi

Fuel pressure 20 IWC → 12.7 psi

Fuel pressure 30 IWC → 13.1 psi

Fuel pressure 40 IWC → 13.5 psi

System Diagram

- 1) Upstream gaseous fuel supply
- 2) Mass Flow Gas Valve (MFG)
- 3) Engine and related engine components
- 4) Engine Control Module (ECM)

IMAGE 1

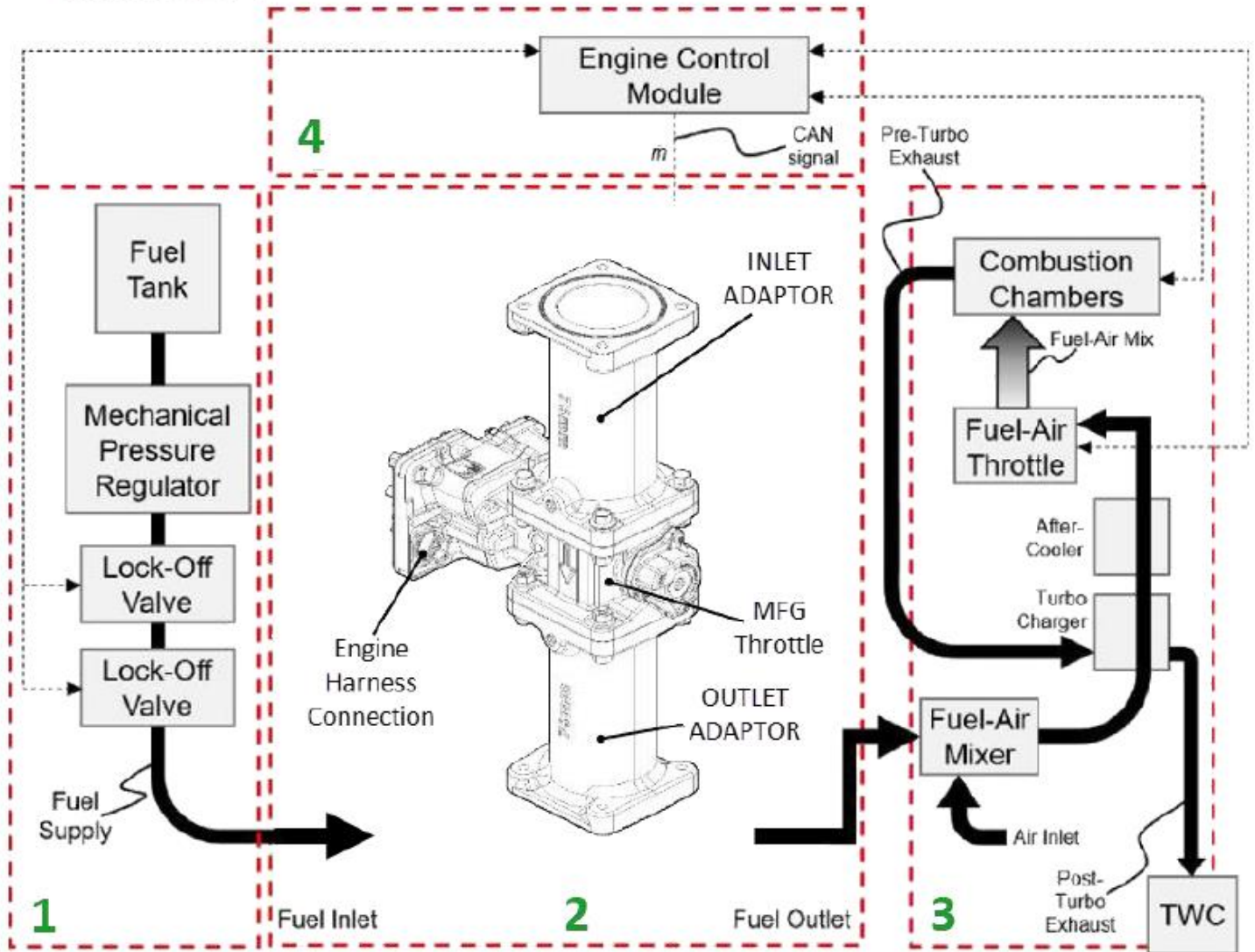

Mass Fuel Gas (MFG) Diagnostic Trouble Codes

Note:

The images below each MFG DTC show the adapter harness that's used to adapt the EPR1 connector to the MFG valve.

| Description | DTC | SPN | FMI |
|--|------|--------|-----|
| MFG RLV Test Failed | 103C | 2807 | 31 |
| MFG Main Comm Lost | 101A | 520270 | 31 |
| MFG Internal Circuitry Fault Detection | 101B | 520271 | 12 |
| MFG Unable to Reach Higher TPS | 1020 | 520276 | 31 |
| MFG Unable to Reach Lower TPS | 1021 | 520277 | 31 |
| MFG Supply Voltage High | 1022 | 520278 | 3 |
| MFG Supply Voltage Low | 1023 | 520278 | 4 |
| MFG Fluid Temperature Voltage High | 1024 | 520279 | 3 |
| MFG Fluid Temperature Voltage Low | 1025 | 520279 | 4 |
| MFG Upstream Pressure Voltage High | 1026 | 520280 | 3 |
| MFG Upstream Pressure Voltage Low | 1027 | 520280 | 4 |
| MFG Downstream Pressure Voltage High | 1028 | 520281 | 3 |
| MFG Downstream Pressure Voltage Low | 1029 | 520281 | 4 |
| MFG Delta Pressure zVolt Voltage High | 102A | 520282 | 3 |
| MFG Delta Pressure zVolt Voltage Low | 102B | 520282 | 4 |
| MFG Delta Pressure Voltage High | 102C | 520283 | 3 |
| MFG Delta Pressure Voltage Low | 102D | 520283 | 4 |
| MFG General Fault | 102E | 520284 | 31 |

DTC 101A - MFG Main Comm Lost

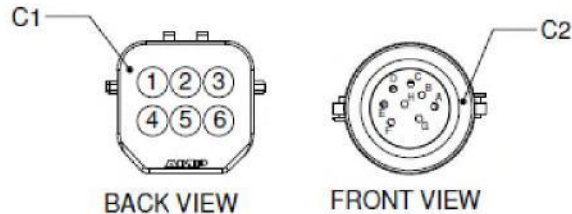
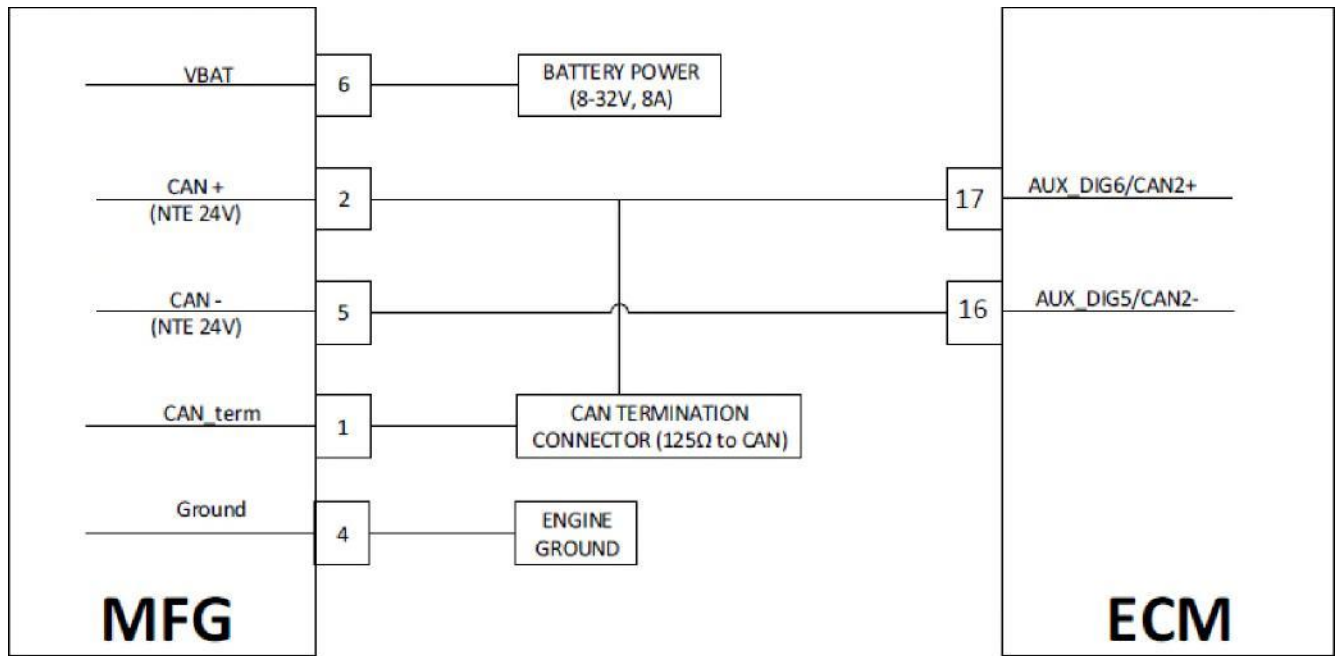

| FROM TO CONNECTOR CHART | | |
|-------------------------|----|----|
| WIRE COLOR | C1 | C2 |
| RED W/ WHITE STRIPE | 5 | A |
| RED W/ TAN STRIPE | 6 | B |
| BLACK | 4 | C |
| WHITE | 1 | D |
| RED W/ BLACK STRIPE | 2 | E |

Conditions for Setting the DTC

- Check Condition: Engine Running
- Fault Condition: ECU received no communication from the MFG for .5 seconds
- MIL: ON during active fault
- Engine shutdown

Fault Description

This fault sets if the ECM loses CAN communication with the MFG. The fault indicates that the ECM is no longer receiving CAN packets from the MFG which also results in the MFG not receiving communication from the ECM. This is often the result of a power loss at the MFG or improper CAN termination or wiring.

DTC 101B - MFG Internal Circuitry Fault Detection

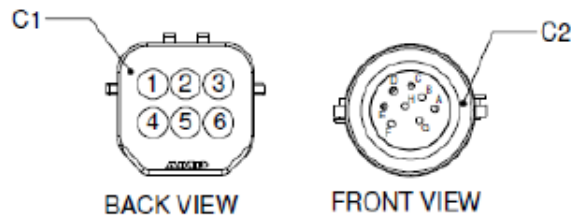
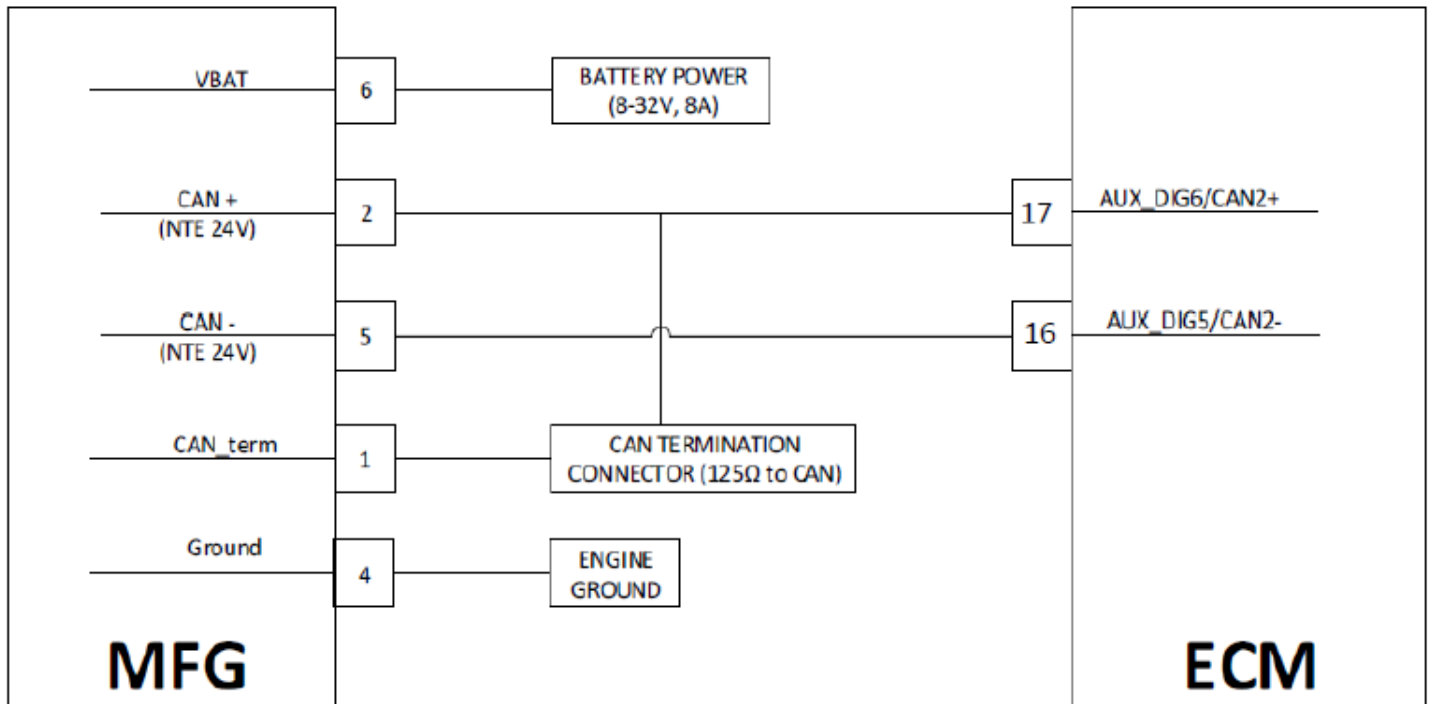

| FROM TO CONNECTOR CHART | | |
|-------------------------|----|----|
| WIRE COLOR | C1 | C2 |
| RED W/ WHITE STRIPE | 5 | A |
| RED W/ TAN STRIPE | 6 | B |
| BLACK | 4 | C |
| WHITE | 1 | D |
| RED W/ BLACK STRIPE | 2 | E |

Conditions for Setting the DTC

- Check Condition: Key On, Engine Running
- Fault Condition: MFG detects an internal circuitry fault
- MIL: ON during active fault
- Engine shutdown

Fault Description

This fault will set if the MFG detects a COP (Watchdog) fault or fails to execute any of the real-time loops in a timely manner. The fault is transmitted from the MFA/AT to the ECM via CAN..

Diagnostic Aid

- Replace MFG with known good unit and retest.

DTC 102A - MFG Delta Pressure zVoltage High

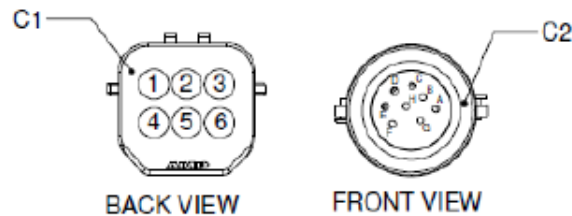
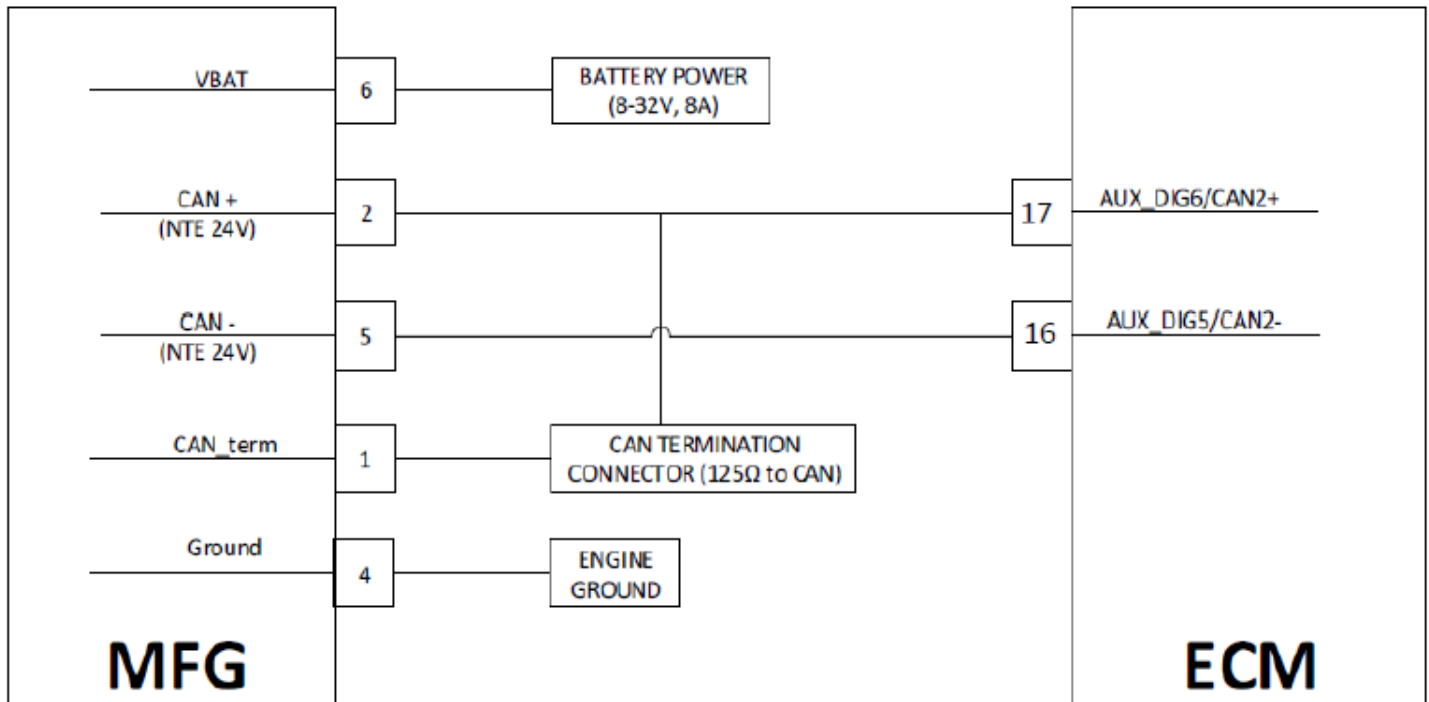

| FROM TO CONNECTOR CHART | | |
|-------------------------|----|----|
| WIRE COLOR | C1 | C2 |
| RED W/ WHITE STRIPE | 5 | A |
| RED W/ TAN STRIPE | 6 | B |
| BLACK | 4 | C |
| WHITE | 1 | D |
| RED W/ BLACK STRIPE | 2 | E |

Conditions for Setting the DTC

- Check Condition: Engine Running or cranking
- Fault Condition: Fault is diagnosed internally within the MFG then relayed to the ECM via CAN communication
- MIL: ON during active fault
- Engine shutdown

Fault Description

This fault will set if the MFG fluid delta pressure sensor thermal compensation circuit output voltage is higher than the internally-defined high voltage limit.

Diagnostic Aid

- Replace MFG with known good unit and retest.

DTC 102A - MFG Delta Pressure zVoltage High

| Step | Action | Value(s) | Yes | No |
|------|--|---------------|----------------|--------------------------------|
| 1 | Did you perform the On-Board (OBD) System Check? | - | Go to Step (2) | Go to OBD System Check Section |
| 2 | Key OFF Engine Running System Mode ="Running" Clear fault with DST and see if the fault resets | Fault resets? | Go to Step (3) | Go to Step (4) |
| 3 | Replace MFG and re-test | | | - |
| 4 | Intermittent problem – unable to diagnose at this time | | | |

DTC 102B - MFG Delta Pressure zVoltage High

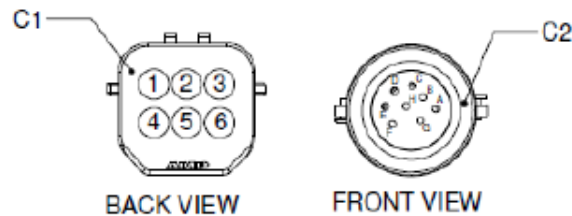
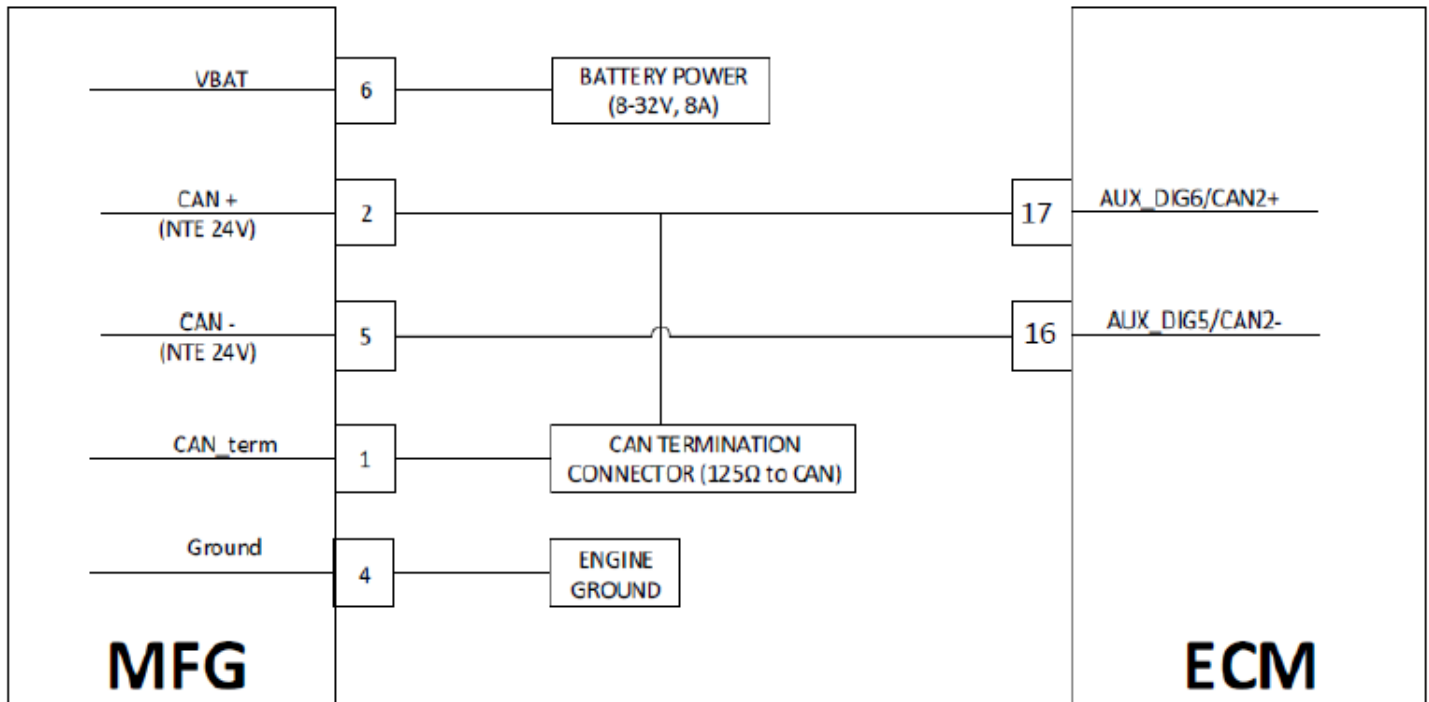

| FROM TO CONNECTOR CHART | | |
|-------------------------|----|----|
| WIRE COLOR | C1 | C2 |
| RED W/ WHITE STRIPE | 5 | A |
| RED W/ TAN STRIPE | 6 | B |
| BLACK | 4 | C |
| WHITE | 1 | D |
| RED W/ BLACK STRIPE | 2 | E |

Conditions for Setting the DTC

- Check Condition: Engine Running or cranking
- Fault Condition: Fault is diagnosed internally within the MFG then relayed to the ECM via CAN communication
- MIL: ON during active fault
- Engine shutdown

Fault Description

This fault will set if the MFG fluid delta pressure sensor thermal compensation circuit output voltage is lower than the internally-defined high voltage limit.

Diagnostic Aid

- Replace MFG with known good unit and retest.

DTC 102B - MFG Delta Pressure zVoltage High

| Step | Action | Value(s) | Yes | No |
|------|--|---------------|----------------|--------------------------------|
| 1 | Did you perform the On-Board (OBD) System Check? | - | Go to Step (2) | Go to OBD System Check Section |
| 2 | Key OFF Engine Running System Mode ="Running" Clear fault with DST and see if the fault resets | Fault resets? | Go to Step (3) | Go to Step (4) |
| 3 | Replace MFG and re-test | | | - |
| 4 | Intermittent problem – unable to diagnose at this time | | | |

DTC 102C - MFG Delta Pressure Voltage High

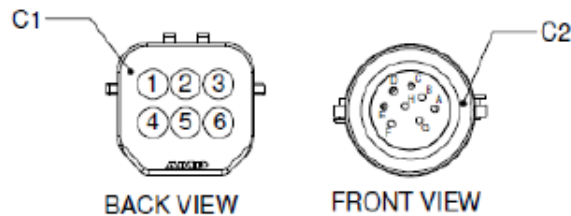
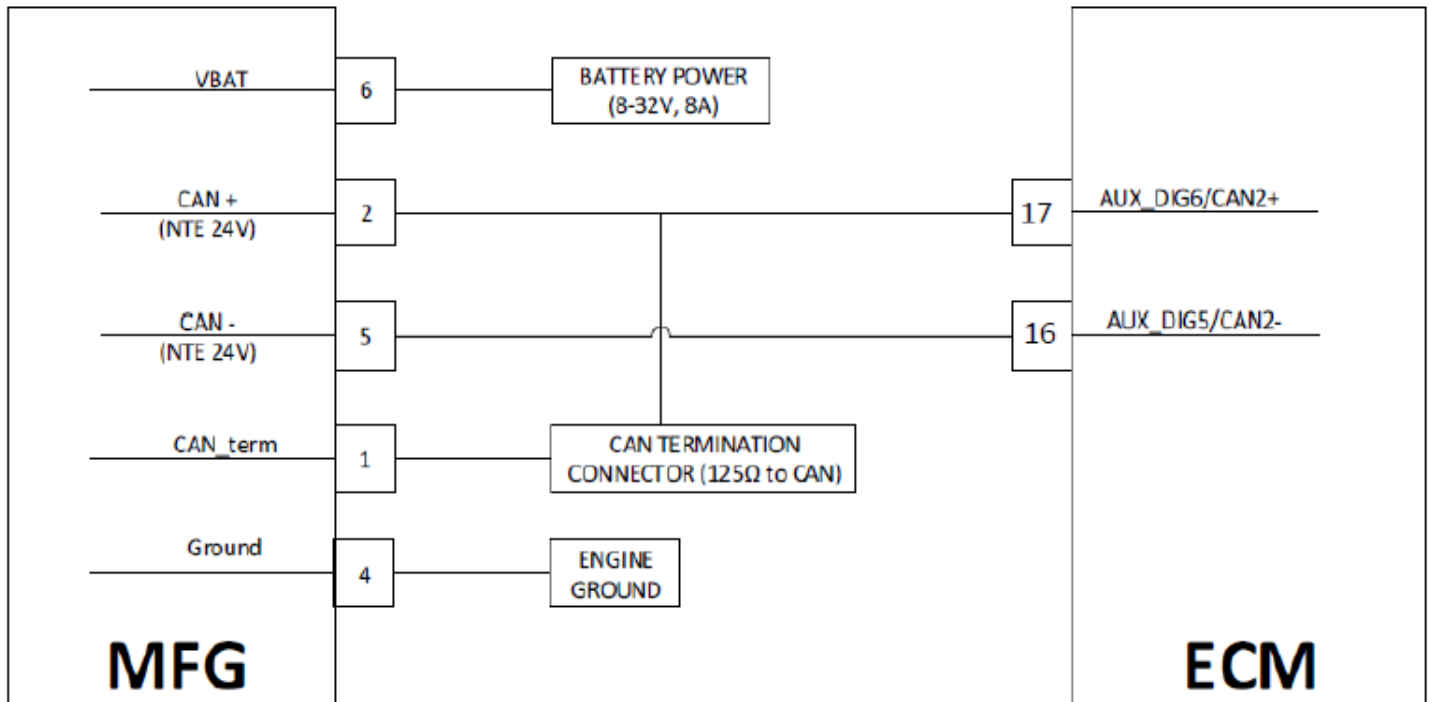

| FROM TO CONNECTOR CHART | | |
|-------------------------|----|----|
| WIRE COLOR | C1 | C2 |
| RED W/ WHITE STRIPE | 5 | A |
| RED W/ TAN STRIPE | 6 | B |
| BLACK | 4 | C |
| WHITE | 1 | D |
| RED W/ BLACK STRIPE | 2 | E |

Conditions for Setting the DTC

- Check Condition: Engine Running or cranking
- Fault Condition: Fault is diagnosed internally within the MFG then relayed to the ECM via CAN communication
- MIL: ON during active fault
- Engine shutdown

Fault Description

This fault will set if the MFG fluid delta pressure sensor output voltage is lower than the internally-defined high voltage limit.

Diagnostic Aid

- Replace MFG with known good unit and retest.

DTC 102C - MFG Delta Pressure Voltage High

| Step | Action | Value(s) | Yes | No |
|-------------|--|-----------------|----------------|--------------------------------|
| 1 | Did you perform the On-Board (OBD) System Check? | - | Go to Step (2) | Go to OBD System Check Section |
| 2 | Key OFF Engine Running System Mode ="Running" Clear fault with DST and see if the fault resets | Fault resets? | Go to Step (3) | Go to Step (4) |
| 3 | Replace MFG and re-test | | | - |
| 4 | Intermittent problem – unable to diagnose at this time | | | |

DTC 102D - MFG Delta Pressure Voltage Low

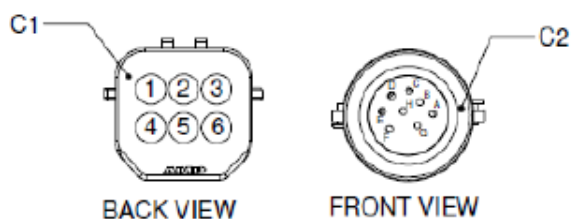
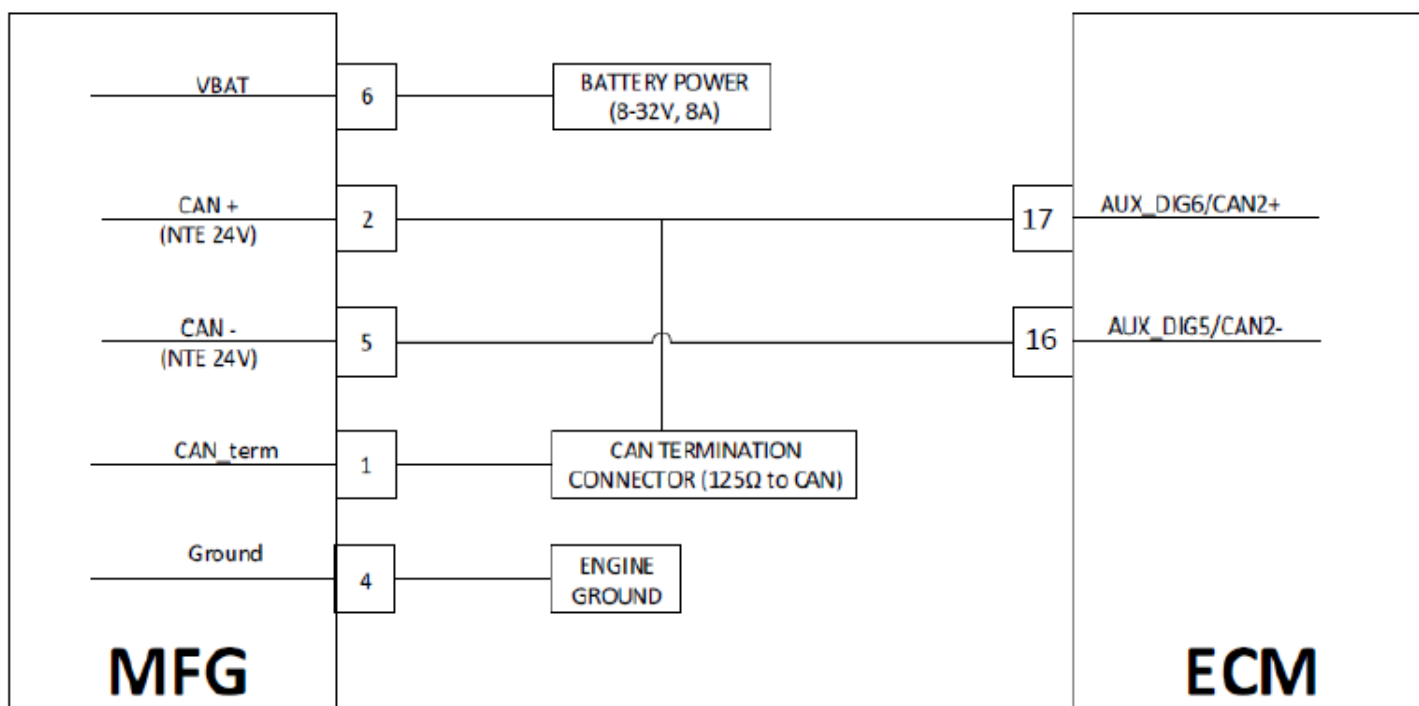

| FROM TO CONNECTOR CHART | | |
|-------------------------|----|----|
| WIRE COLOR | C1 | C2 |
| RED W/ WHITE STRIPE | 5 | A |
| RED W/ TAN STRIPE | 6 | B |
| BLACK | 4 | C |
| WHITE | 1 | D |
| RED W/ BLACK STRIPE | 2 | E |

Conditions for Setting the DTC

- Check Condition: Engine Running or cranking
- Fault Condition: Fault is diagnosed internally within the MFG then relayed to the ECM via CAN communication
- MIL: ON during active fault
- Engine shutdown

Fault Description

This fault will set if the MFG fluid delta pressure sensor output voltage is lower than the internally-defined high voltage limit.

Diagnostic Aid

- Replace MFG with known good unit and retest.

DTC 102D - MFG Delta Pressure Voltage Low

| Step | Action | Value(s) | Yes | No |
|-------------|--|-----------------|----------------|--------------------------------|
| 1 | Did you perform the On-Board (OBD) System Check? | - | Go to Step (2) | Go to OBD System Check Section |
| 2 | Key OFF Engine Running System Mode ="Running" Clear fault with DST and see if the fault resets | Fault resets? | Go to Step (3) | Go to Step (4) |
| 3 | Replace MFG and re-test | | | - |
| 4 | Intermittent problem – unable to diagnose at this time | | | |

DTC 102E - MFG Delta Pressure Voltage Low

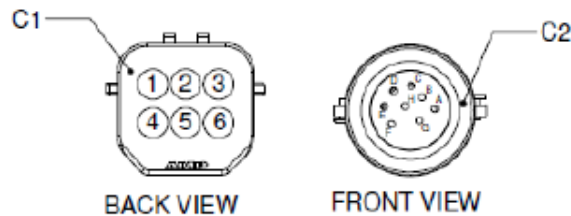
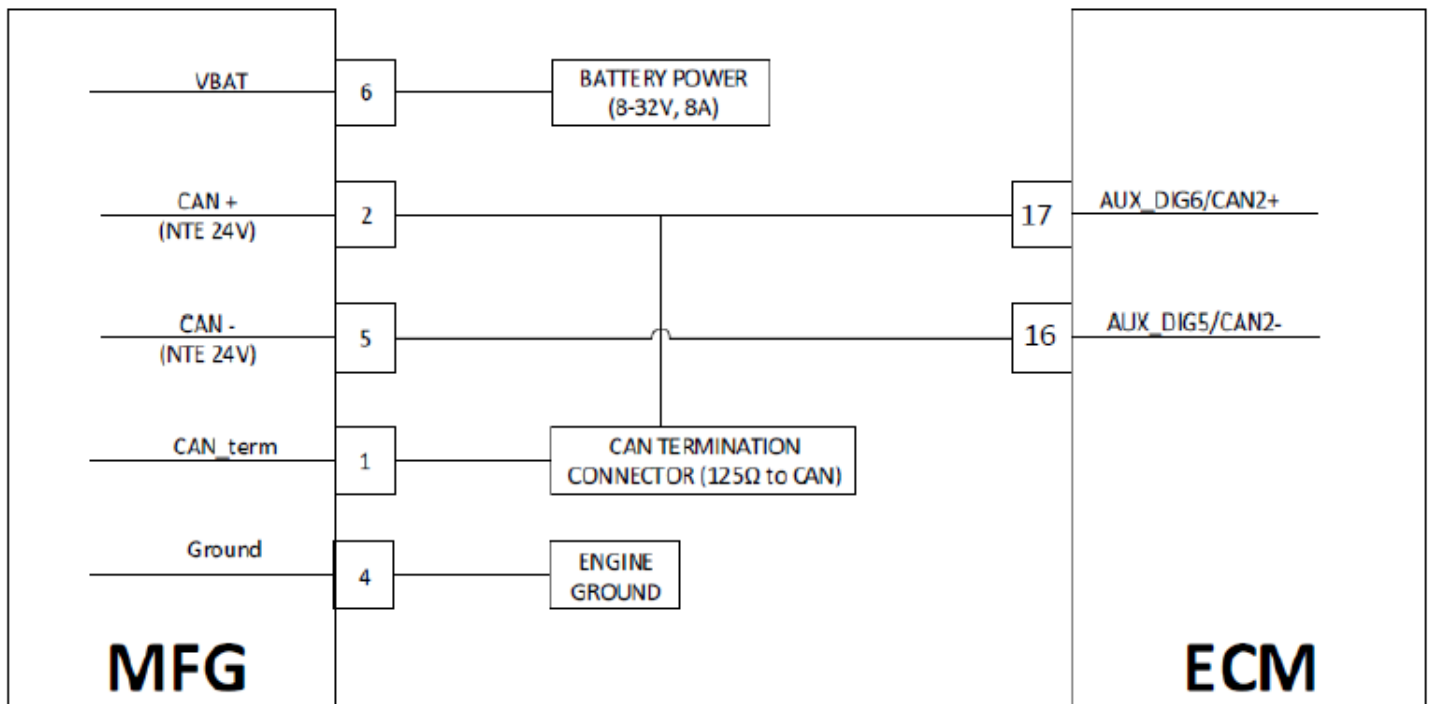

| FROM TO CONNECTOR CHART | | |
|-------------------------|----|----|
| WIRE COLOR | C1 | C2 |
| RED W/ WHITE STRIPE | 5 | A |
| RED W/ TAN STRIPE | 6 | B |
| BLACK | 4 | C |
| WHITE | 1 | D |
| RED W/ BLACK STRIPE | 2 | E |

Conditions for Setting the DTC

- Check Condition: Key On
- Fault Condition: Fault is diagnosed internally within the MFG then relayed to the ECM via CAN communication
- MIL: ON during active fault
- Engine shutdown

Fault Description

This fault will set after a latch period if the MFG experiences a general error which includes a EEPROM failures, internal timing overload failures, or a general calibration issues.

Diagnostic Aid

- Replace MFG with known good unit and retest.

DTC 102E - MFG Delta Pressure Voltage Low

| Step | Action | Value(s) | Yes | No |
|-------------|--|-----------------|----------------|--------------------------------|
| 1 | Did you perform the On-Board (OBD) System Check? | - | Go to Step (2) | Go to OBD System Check Section |
| 2 | Key OFF Engine Running System Mode ="Running" Clear fault with DST and see if the fault resets | Fault resets? | Go to Step (3) | Go to Step (4) |
| 3 | Replace MFG and re-test | | | - |
| 4 | Intermittent problem – unable to diagnose at this time | | | |

DTC 103C - MFG RLV Test Failed

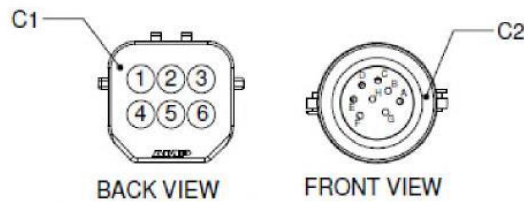
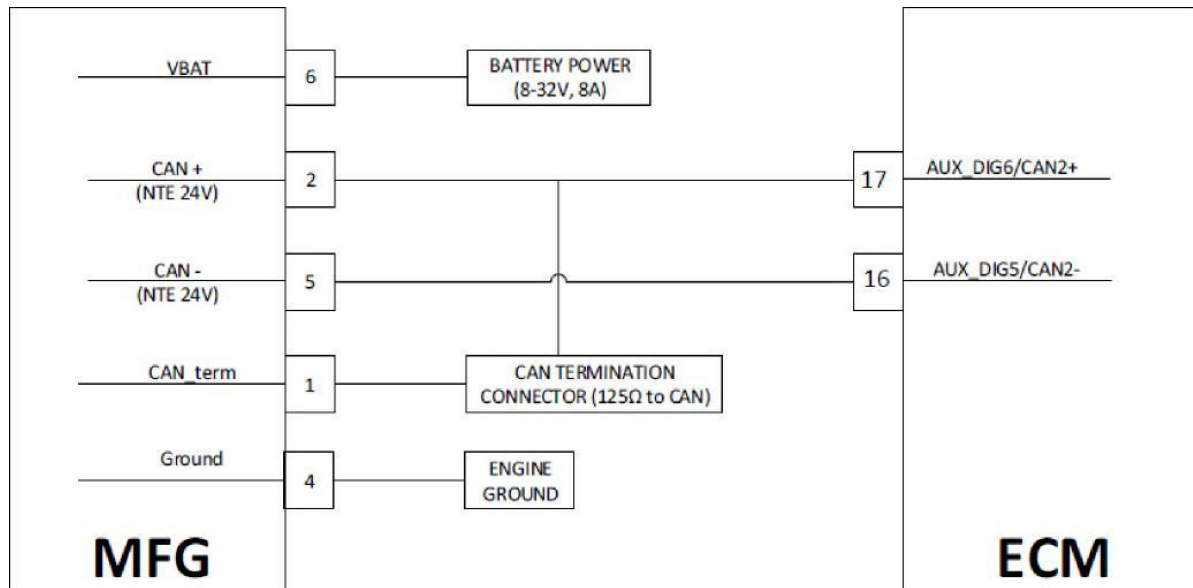

| FROM TO CONNECTOR CHART | | |
|-------------------------|----|----|
| WIRE COLOR | C1 | C2 |
| RED W/ WHITE STRIPE | 5 | A |
| RED W/ TAN STRIPE | 6 | B |
| BLACK | 4 | C |
| WHITE | 1 | D |
| RED W/ BLACK STRIPE | 2 | E |

Conditions for Setting The DTC

- Check Conditions: Engine Running
- Fault Conditions: Fuel run-out engine run time > " Number of engine warm cycles between runs
" Engine hours elapsed before forced test run
- MIL: ON during active fault
- Engine shutdown

Fault Description

If MFG redundant lockoff verification is enabled, MFG applications will verify the operation of the secondary lockoff device when the number of warm engine cycles or elapsed engine hours specified for the MFG RLV test failed diagnostic have occurred since the previous execution of the test.

The test starts when the key is turned off or a remote engine stop command is received. Fuel run-out is engaged and only the secondary lockoff device is closed. The test is successful if the engine stops before the fuel run-out engine run time threshold calibrated for the MFG RLV test failed diagnostic is exceeded. The test fails if that diagnostic becomes active-latched.

DTC 1020 - MFG Unable to Reach Higher TPS

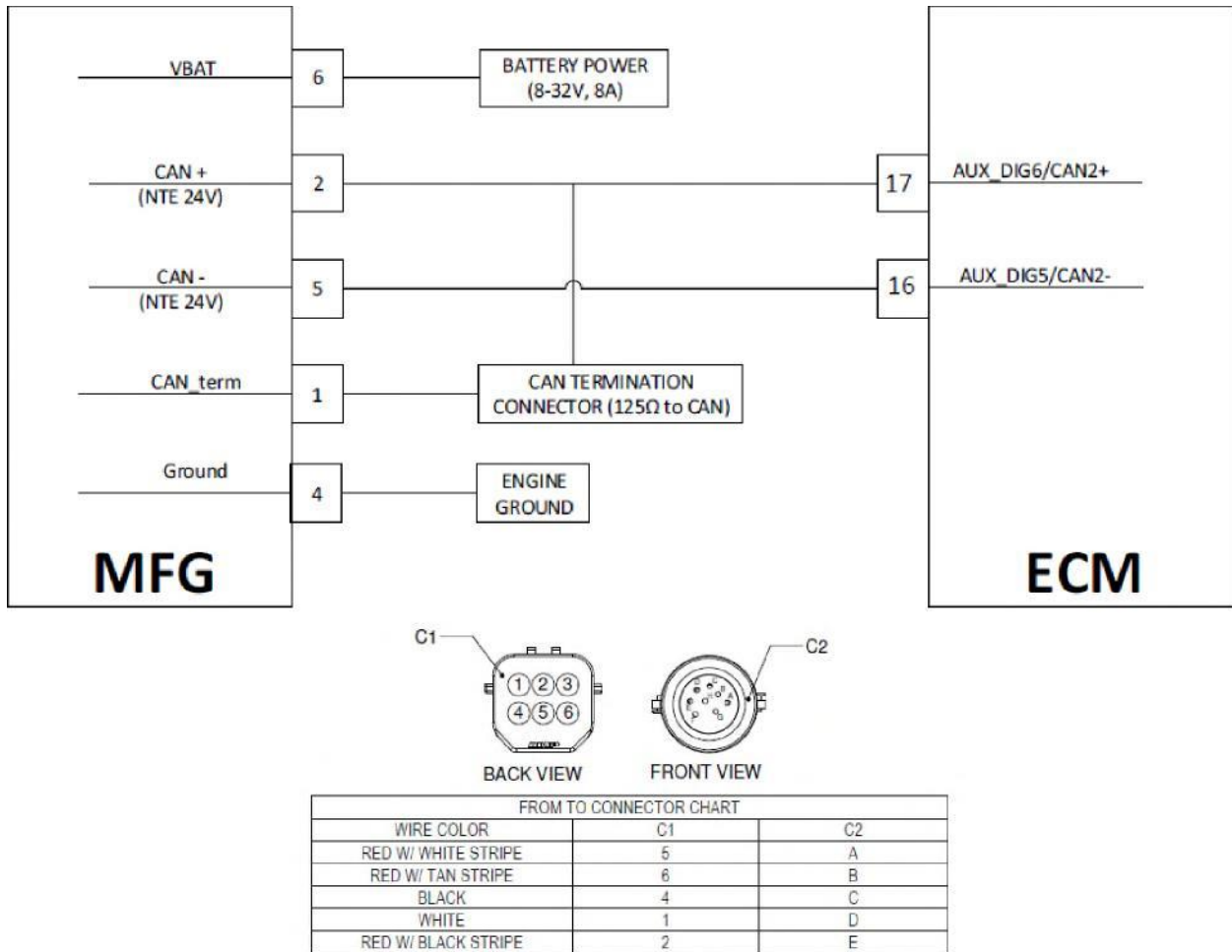

Conditions for Setting the DTC

- Check Condition: Engine Running
- Fault Condition: Fault is diagnosed internally within the MFG then relayed to the ECM via CAN communication.
- MIL: ON during active fault
- Engine shutdown

Fault Description

This fault will set after a latch period if the MFG throttle command is lower than the actual MFG throttle position as defined internally for longer than the defined threshold time.

Diagnostic Aid

- This fault is most often caused by a mechanical problem with the throttle. Testing the engine with a known good throttle or swapping the throttles side to side on a G-Drive engine and seeing if the problem moves are good ways to diagnose a stuck throttle.
- Replace MFG with known good unit and retest.

DTC 1022 - MFG Supply Voltage High

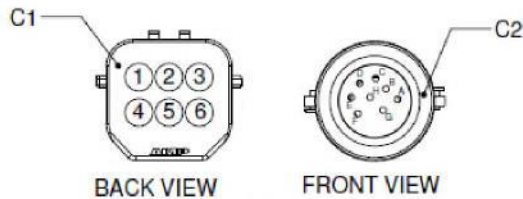
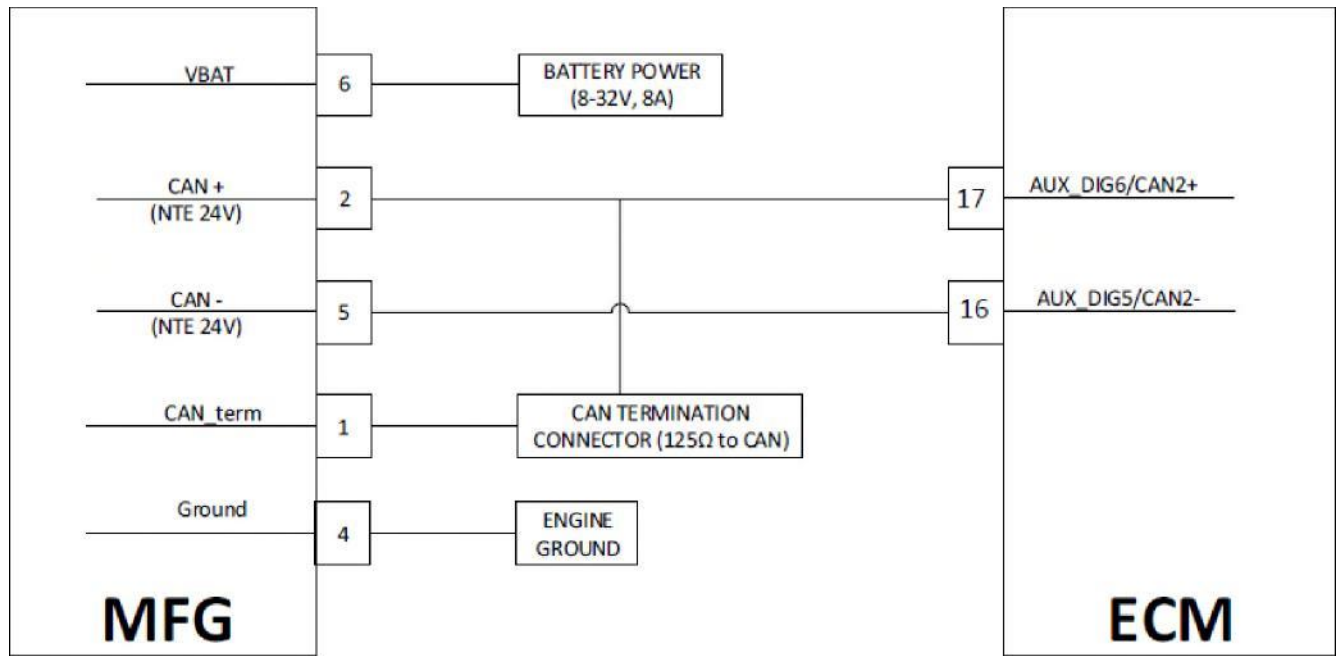

| FROM TO CONNECTOR CHART | | |
|-------------------------|----|----|
| WIRE COLOR | C1 | C2 |
| RED W/ WHITE STRIPE | 5 | A |
| RED W/ TAN STRIPE | 6 | B |
| BLACK | 4 | C |
| WHITE | 1 | D |
| RED W/ BLACK STRIPE | 2 | E |

Conditions for Setting the DTC

- Check Condition: Key on, Engine running
- Fault Condition: Fault is diagnosed internally within the MFG then relayed to the ECM via CAN communication
- MIL: ON during active fault
- Engine shutdown

Fault Description

This fault will set after a latch period if the internally measured voltage feedback of the MFG throttle is higher than the internally-defined high voltage limit anytime the engine is running or stopped at key-on (if applicable).

Diagnostic Aid

- Replace MFG with known good unit and retest.

DTC 1022 - MFG Supply Voltage High

| Step | Action | Value(s) | Yes | No |
|------|---|-----------------------|----------------|--------------------------------|
| 1 | Did you perform the On-Board (OBD) System Check? | - | Go to Step (2) | Go to OBD System Check Section |
| 2 | Key ON, Engine Running System Mode = "Running | Does DTC Display DTC? | Go to Step (3) | Go to Step (4) |
| 3 | Wire connected to terminal at the MFG is partially or completely shorted to power (Vbat, Vsw, Vrelay, etc.) | | | |
| 4 | Intermittent problem | | | |

DTC 1023 - MFG Supply Voltage Low

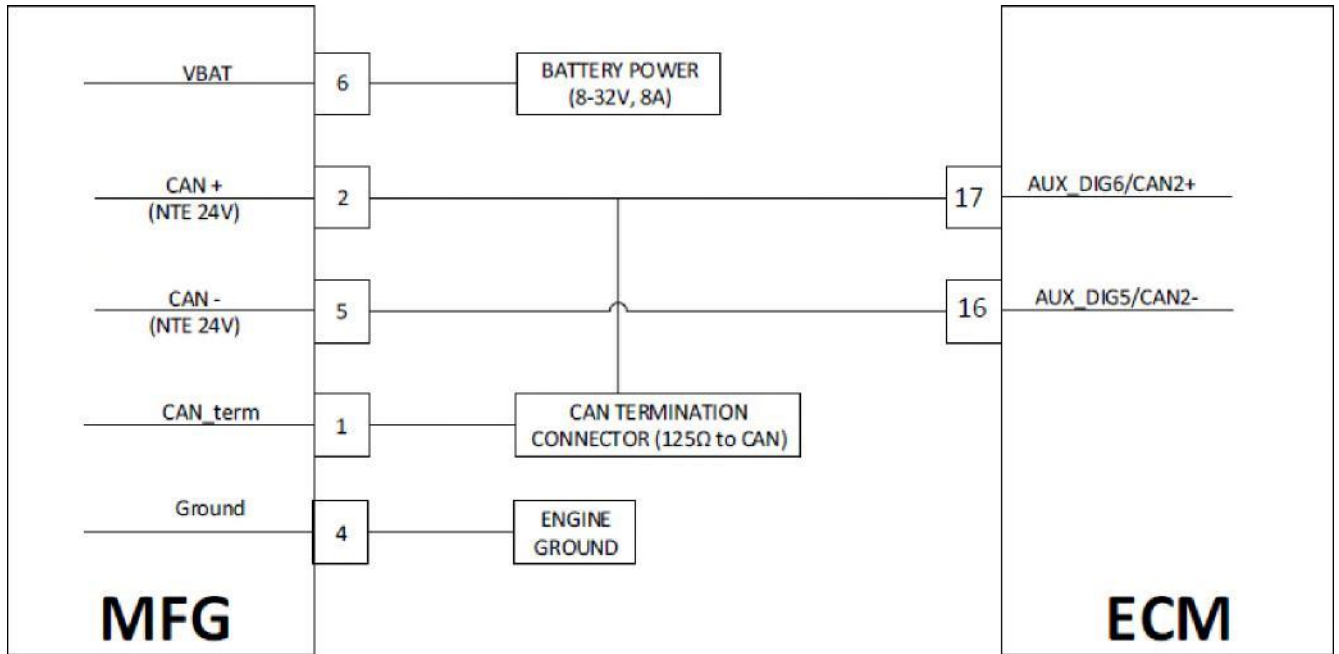

| FROM TO CONNECTOR CHART | | |
|-------------------------|----|----|
| WIRE COLOR | C1 | C2 |
| RED W/ WHITE STRIPE | 5 | A |
| RED W/ TAN STRIPE | 6 | B |
| BLACK | 4 | C |
| WHITE | 1 | D |
| RED W/ BLACK STRIPE | 2 | E |

Conditions for Setting the DTC

- Check Condition: Key on, Engine running
- Fault Condition: Fault is diagnosed internally within the MFG then relayed to the ECM via CAN communication
- MIL: ON during active fault
- Engine shutdown

Fault Description

This fault will set after a latch period if the internally measured voltage feedback of the MFG throttle is lower than the internally-defined low voltage limit anytime the engine is running or stopped at key-on (if applicable).

Diagnostic Aid

- Replace MFG with known good unit and retest.

DTC 1023 - MFG Supply Voltage Low

| Step | Action | Value(s) | Yes | No |
|-------------|---|-----------------------|----------------|--------------------------------|
| 1 | Did you perform the On-Board (OBD) System Check? | - | Go to Step (2) | Go to OBD System Check Section |
| 2 | Key ON, Engine Running System Mode = "Running | Does DTC Display DTC? | Go to Step (3) | Go to Step (4) |
| 3 | Wire connected to terminal at the MFG is partially or completely shorted to power (Vbat, Vsw, Vrelay, etc.) Faulty battery or battery connection Faulty MFG | | | |
| 4 | Intermittent problem | | | |

DTC 1024 - MFG Fluid Temperature Voltage High

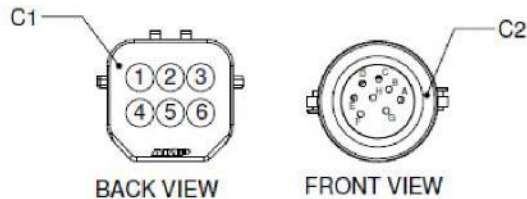
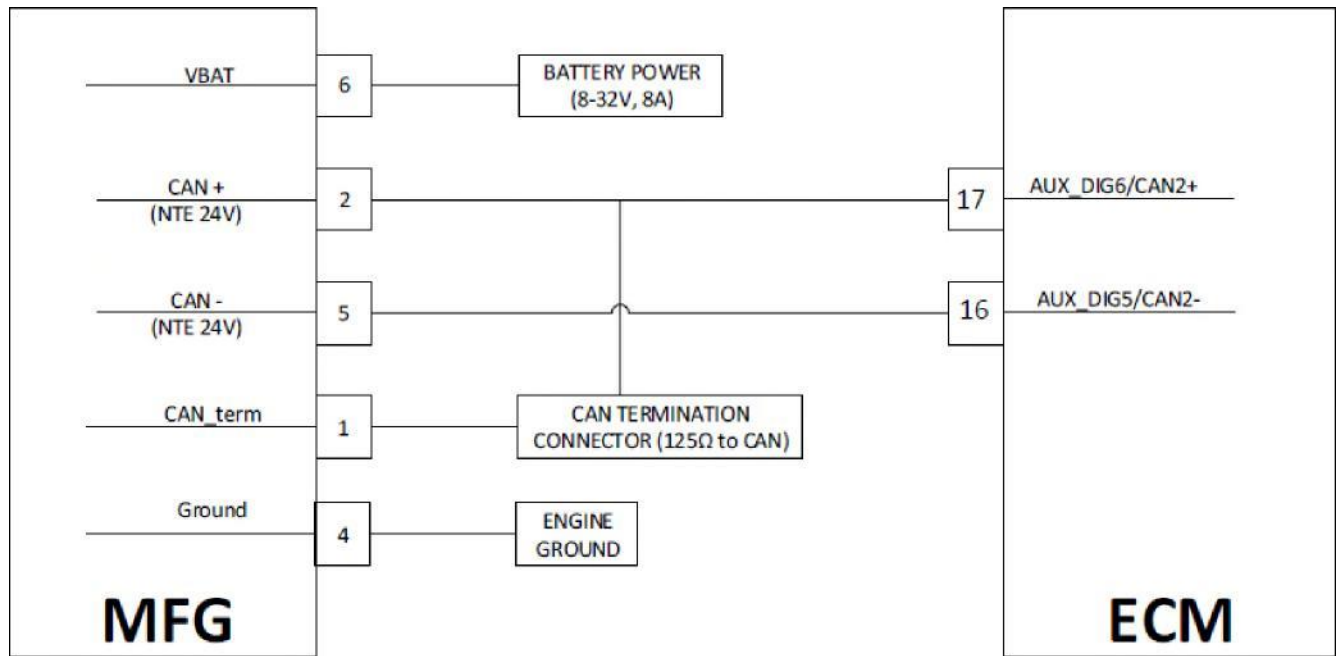

| FROM TO CONNECTOR CHART | | |
|-------------------------|----|----|
| WIRE COLOR | C1 | C2 |
| RED W/ WHITE STRIPE | 5 | A |
| RED W/ TAN STRIPE | 6 | B |
| BLACK | 4 | C |
| WHITE | 1 | D |
| RED W/ BLACK STRIPE | 2 | E |

Conditions for Setting the DTC

- Check Condition: Engine Running
- Fault Condition: Fault is diagnosed internally within the MFG then relayed to the ECM via CAN communication
- MIL: ON during active fault
- Engine shutdown

Fault Description

This fault will set if the MFG fluid temperature sensor output voltage is higher than the internally defined high voltage limit.

Diagnostic Aid

- Replace MFG with known good unit and retest.

DTC 1024 - MFG Fluid Temperature Voltage High

| Step | Action | Value(s) | Yes | No |
|-------------|---|-----------------|----------------|--------------------------------|
| 1 | Did you perform the On-Board (OBD) System Check? | - | Go to Step (2) | Go to OBD System Check Section |
| 2 | Key ON, Engine Running System Mode = "Running Clear fault with DST and see if the fault resets. | Fault resets? | Go to Step (3) | Go to Step (4) |
| 3 | Intermittent Problem – unable to diagnose at this time | | | |
| 4 | Replace MFG and re-test | | | |

DTC 1025 - MFG Fluid Temperature Voltage Low

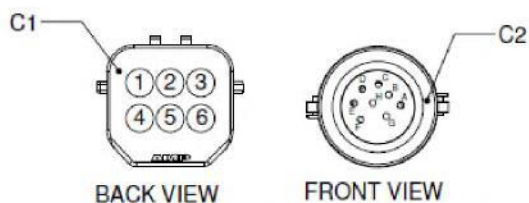
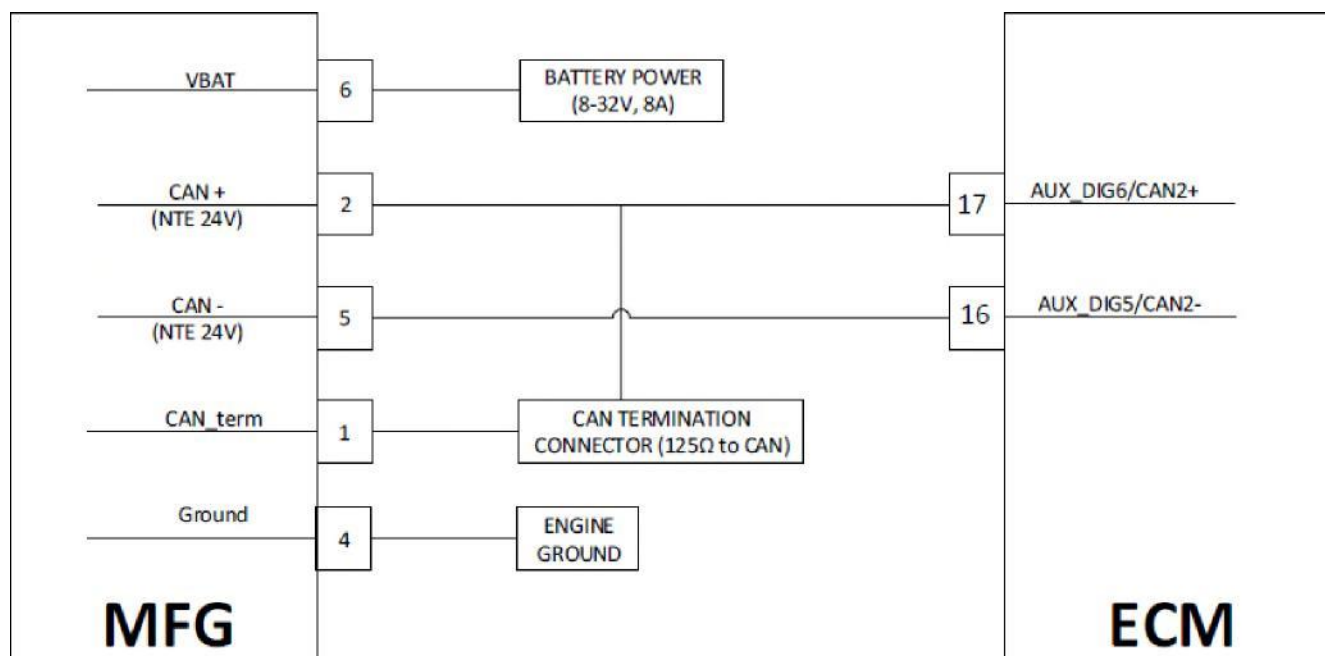

| FROM TO CONNECTOR CHART | | |
|-------------------------|----|----|
| WIRE COLOR | C1 | C2 |
| RED W/ WHITE STRIPE | 5 | A |
| RED W/ TAN STRIPE | 6 | B |
| BLACK | 4 | C |
| WHITE | 1 | D |
| RED W/ BLACK STRIPE | 2 | E |

Conditions for Setting the DTC

- Check Condition: Engine Running
- Fault Condition: Fault is diagnosed internally within the MFG then relayed to the ECM via CAN communication
- MIL: ON during active fault
- Engine shutdown

Fault Description

This fault will set if the MFG fluid temperature sensor output voltage is lower than the internally-defined low voltage limit.

Diagnostic Aid

- Replace MFG with known good unit and retest.

DTC 1025 - MFG Fluid Temperature Voltage Low

| Step | Action | Value(s) | Yes | No |
|-------------|--|-----------------|----------------|--------------------------------|
| 1 | Did you perform the On-Board (OBD) System Check? | - | Go to Step (2) | Go to OBD System Check Section |
| 2 | Key ON, Engine Running System Mode = "Running Clear fault with DST and see if the fault resets | Fault Resets | Go to Step (3) | Go to Step (4) |
| 3 | Replace MFG and retest | | | |
| 4 | Intermittent Problem-unable to diagnose at this time | | | |

DTC 1026 - MFG Upstream Pressure Voltage High

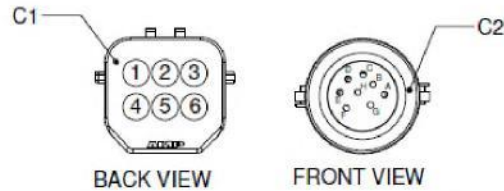
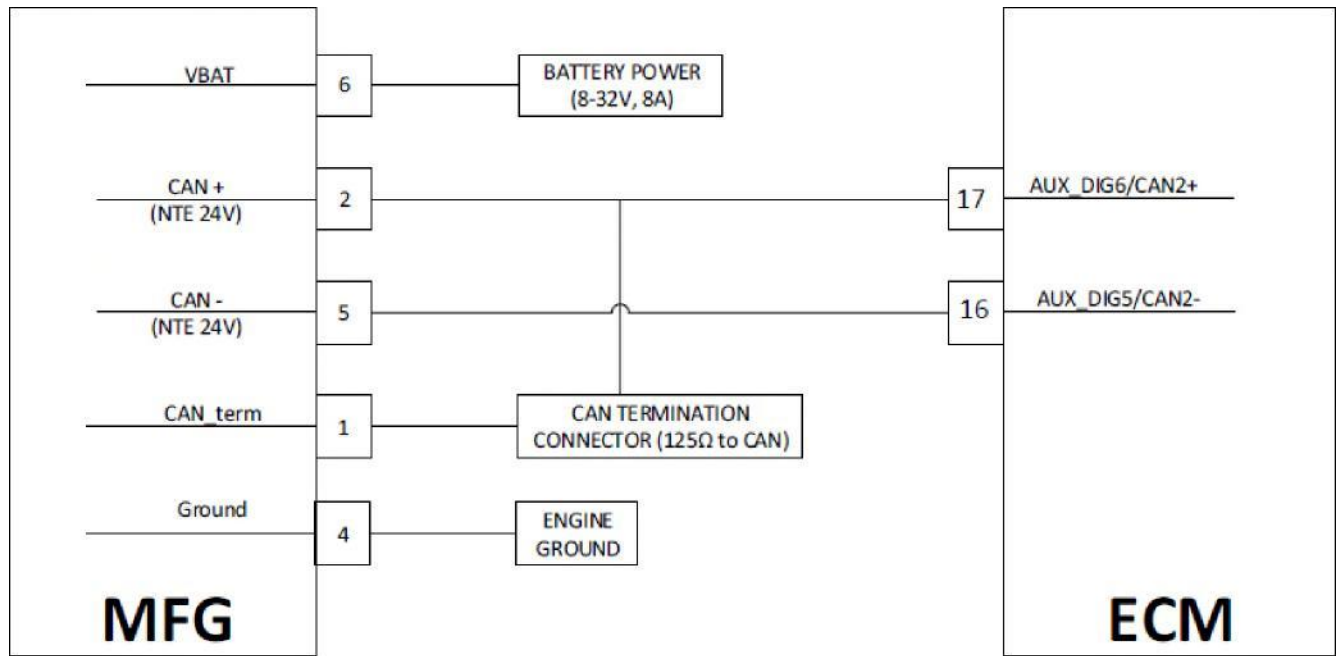

| FROM TO CONNECTOR CHART | | |
|-------------------------|----|----|
| WIRE COLOR | C1 | C2 |
| RED W/ WHITE STRIPE | 5 | A |
| RED W/ TAN STRIPE | 6 | B |
| BLACK | 4 | C |
| WHITE | 1 | D |
| RED W/ BLACK STRIPE | 2 | E |

Conditions for Setting the DTC

- Check Condition: Engine Running or cranking
- Fault Condition: Fault is diagnosed internally within the MFG then relayed to the ECM via CAN communication
- MIL: ON during active fault
- Engine shutdown

Fault Description

This fault will set if the MFG fluid upstream pressure sensor output voltage is higher than the internally-defined high voltage limit.

Diagnostic Aid

- Replace MFG with known good unit and retest.

DTC 1026 - MFG Upstream Pressure Voltage High

| Step | Action | Value(s) | Yes | No |
|-------------|--|-----------------|----------------|--------------------------------|
| 1 | Did you perform the On-Board (OBD) System Check? | - | Go to Step (2) | Go to OBD System Check Section |
| 2 | Key ON, Engine Running System Mode = "Running Clear fault with DST and see if the fault resets | Fault Resets | Go to Step (3) | Go to Step (4) |
| 3 | Replace MFG and retest | | | |
| 4 | Intermittent Problem-unable to diagnose at this time | | | |

DTC 1027 - MFG Upstream Pressure Voltage Low

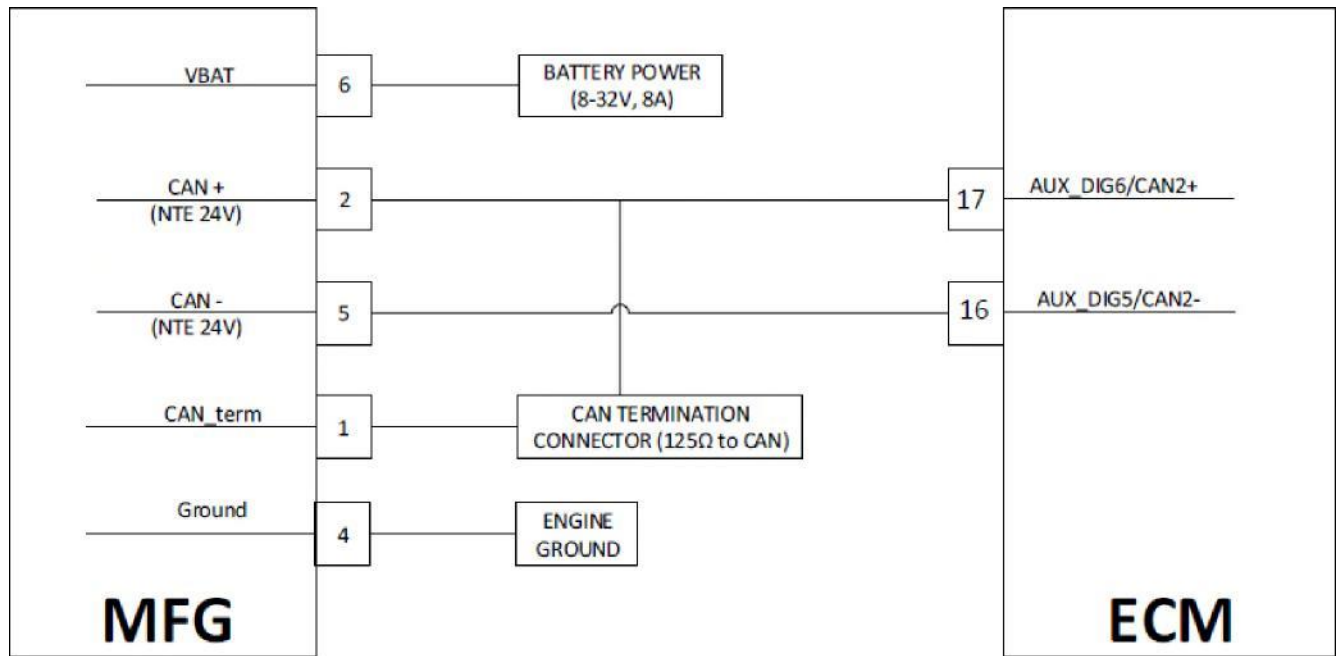

| FROM TO CONNECTOR CHART | | |
|-------------------------|----|----|
| WIRE COLOR | C1 | C2 |
| RED W/ WHITE STRIPE | 5 | A |
| RED W/ TAN STRIPE | 6 | B |
| BLACK | 4 | C |
| WHITE | 1 | D |
| RED W/ BLACK STRIPE | 2 | E |

Conditions for Setting the DTC

- Check Condition: Engine Running or cranking
- Fault Condition: Fault is diagnosed internally within the MFG then relayed to the ECM via CAN communication
- MIL: ON during active fault
- Engine shutdown

Fault Description

This fault will set if the MFG fluid upstream pressure sensor output voltage is lower than the internally-defined low voltage limit.

Diagnostic Aid

- Replace MFG with known good unit and retest.

DTC 1027 - MFG Upstream Pressure Voltage Low

| Step | Action | Value(s) | Yes | No |
|-------------|--|-----------------|----------------|--------------------------------|
| 1 | Did you perform the On-Board (OBD) System Check? | - | Go to Step (2) | Go to OBD System Check Section |
| 2 | Key ON, Engine Running System Mode = "Running Clear fault with DST and see if the fault resets | Fault Resets | Go to Step (3) | Go to Step (4) |
| 3 | Replace MFG and retest | | | |
| 4 | Intermittent Problem-unable to diagnose at this time | | | |

DTC 1028 - MFG Downstream Pressure Voltage High

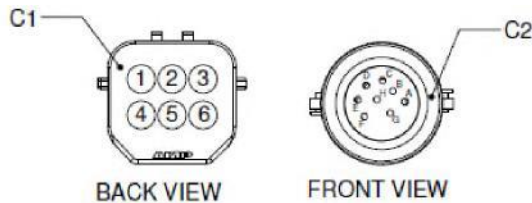
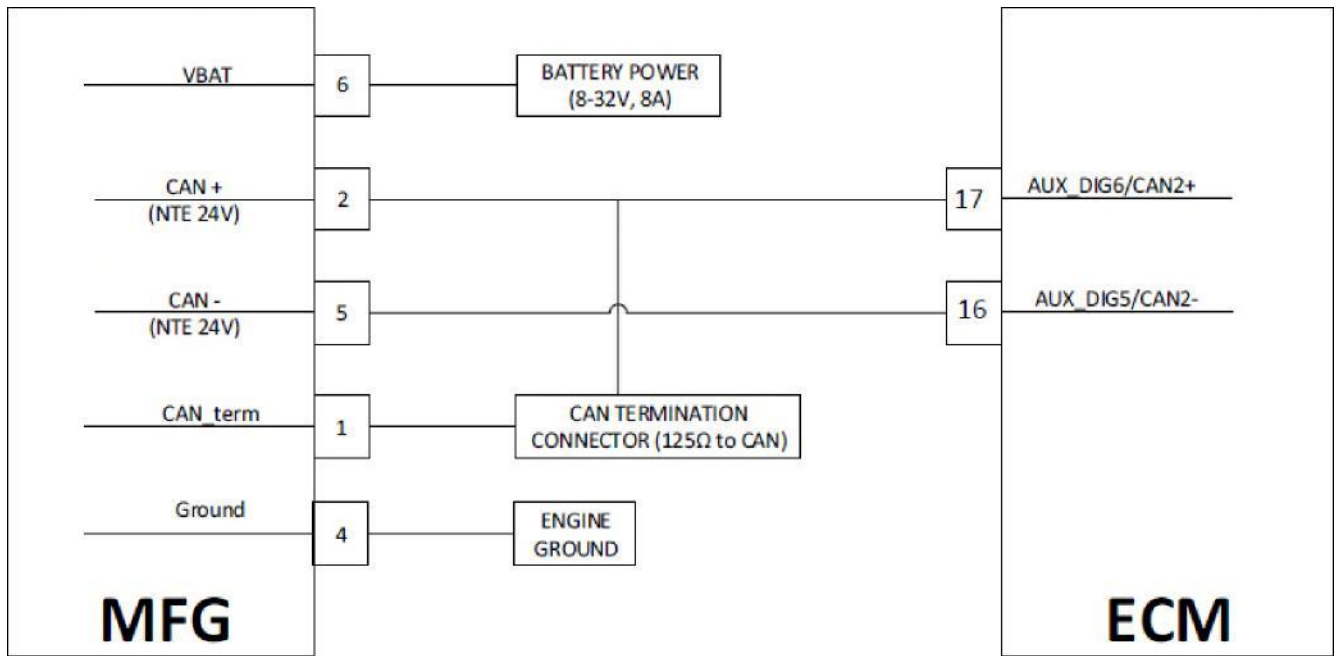

| FROM TO CONNECTOR CHART | | |
|-------------------------|----|----|
| WIRE COLOR | C1 | C2 |
| RED W/ WHITE STRIPE | 5 | A |
| RED W/ TAN STRIPE | 6 | B |
| BLACK | 4 | C |
| WHITE | 1 | D |
| RED W/ BLACK STRIPE | 2 | E |

Conditions for Setting the DTC

- Check Condition: Engine Running or cranking
- Fault Condition: Fault is diagnosed internally within the MFG then relayed to the ECM via CAN communication
- MIL: ON during active fault
- Engine shutdown

Fault Description

This fault will set if the MFG fluid downstream pressure sensor output voltage is higher than the internally-defined high voltage limit.

Diagnostic Aid

- Replace MFG with known good unit and retest.

DTC 1028 - MFG Downstream Pressure Voltage High

| Step | Action | Value(s) | Yes | No |
|-------------|--|-----------------|----------------|--------------------------------|
| 1 | Did you perform the On-Board (OBD) System Check? | - | Go to Step (2) | Go to OBD System Check Section |
| 2 | Key ON, Engine Running System Mode = "Running Clear fault with DST and see if the fault resets | Fault Resets | Go to Step (3) | Go to Step (4) |
| 3 | Replace MFG and retest | | | |
| 4 | Intermittent Problem-unable to diagnose at this time | | | |

DTC 1029 - MFG Downstream Pressure Voltage Low

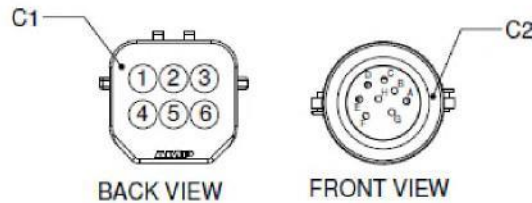
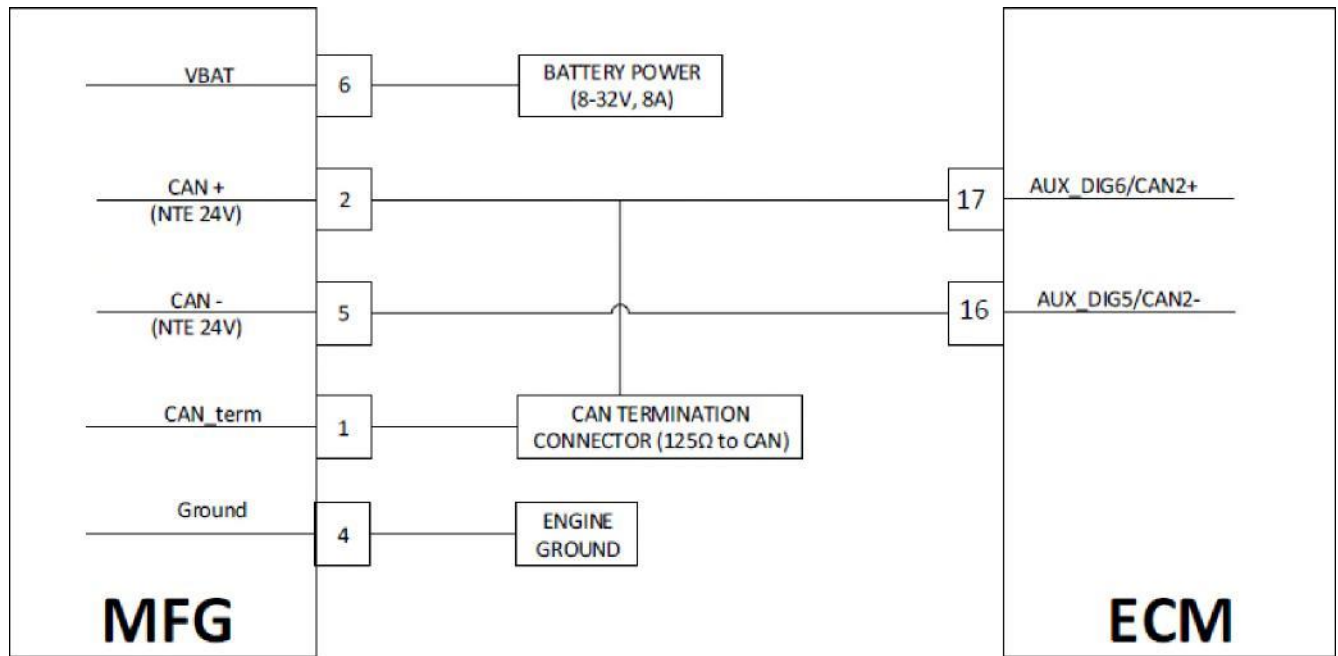

| FROM TO CONNECTOR CHART | | | |
|-------------------------|----|----|--|
| WIRE COLOR | C1 | C2 | |
| RED W/ WHITE STRIPE | 5 | A | |
| RED W/ TAN STRIPE | 6 | B | |
| BLACK | 4 | C | |
| WHITE | 1 | D | |
| RED W/ BLACK STRIPE | 2 | E | |

Conditions for Setting the DTC

- Check Condition: Engine Running or cranking
- Fault Condition: Fault is diagnosed internally within the MFG then relayed to the ECM via CAN communication
- MIL: ON during active fault
- Engine shutdown

Fault Description

This fault will set if the MFG fluid downstream pressure sensor output voltage is lower than the internally-defined lower voltage limit.

Diagnostic Aid

- Replace MFG with known good unit and retest.

DTC 1029 - MFG Downstream Pressure Voltage Low

| Step | Action | Value(s) | Yes | No |
|-------------|--|-----------------|----------------|--------------------------------|
| 1 | Did you perform the On-Board (OBD) System Check? | - | Go to Step (2) | Go to OBD System Check Section |
| 2 | Key ON, Engine Running System Mode = "Running Clear fault with DST and see if the fault resets | Fault Resets | Go to Step (3) | Go to Step (4) |
| 3 | Replace MFG and retest | | | |
| 4 | Intermittent Problem-unable to diagnose at this time | | | |

Pro-Lube Electrical Diagrams

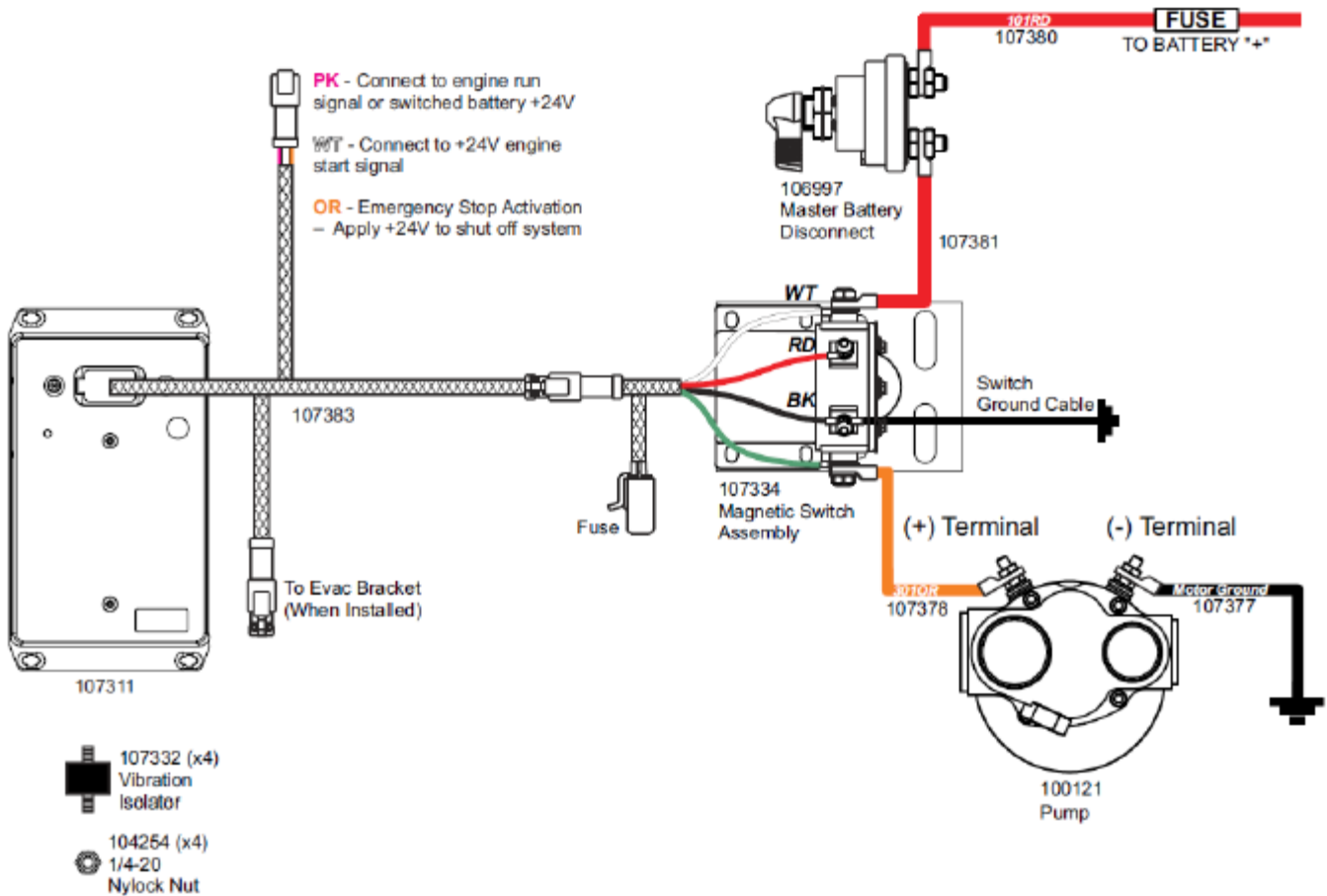

Figure 1. Pre-Lube Module Electrical Diagram

NOTE:

- The pre-lube module must be installed with the isolators and nylon nuts in order to prevent engine vibration damaging the electrical components within the module.
- The WHITE (WH) wire connects to a positive output of the start circuit. The positive coil of the start relay or the "S" terminal on the starter may be used.
- The PINK (PK) wire must connect to a Battery + signal that indicates when the engine is running.
- To enable the emergency stop capability to the pre-lube, an emergency shutoff switch or similar switch supplying +24 VDC to the ORANGE (OR) wire of the main harness will safely shut system off when needed. If no connection is made to orange wire, the pre-lube will continue to run cycles unless the batteries are disconnected.

Pre-Lube Electrical Diagrams – Continued

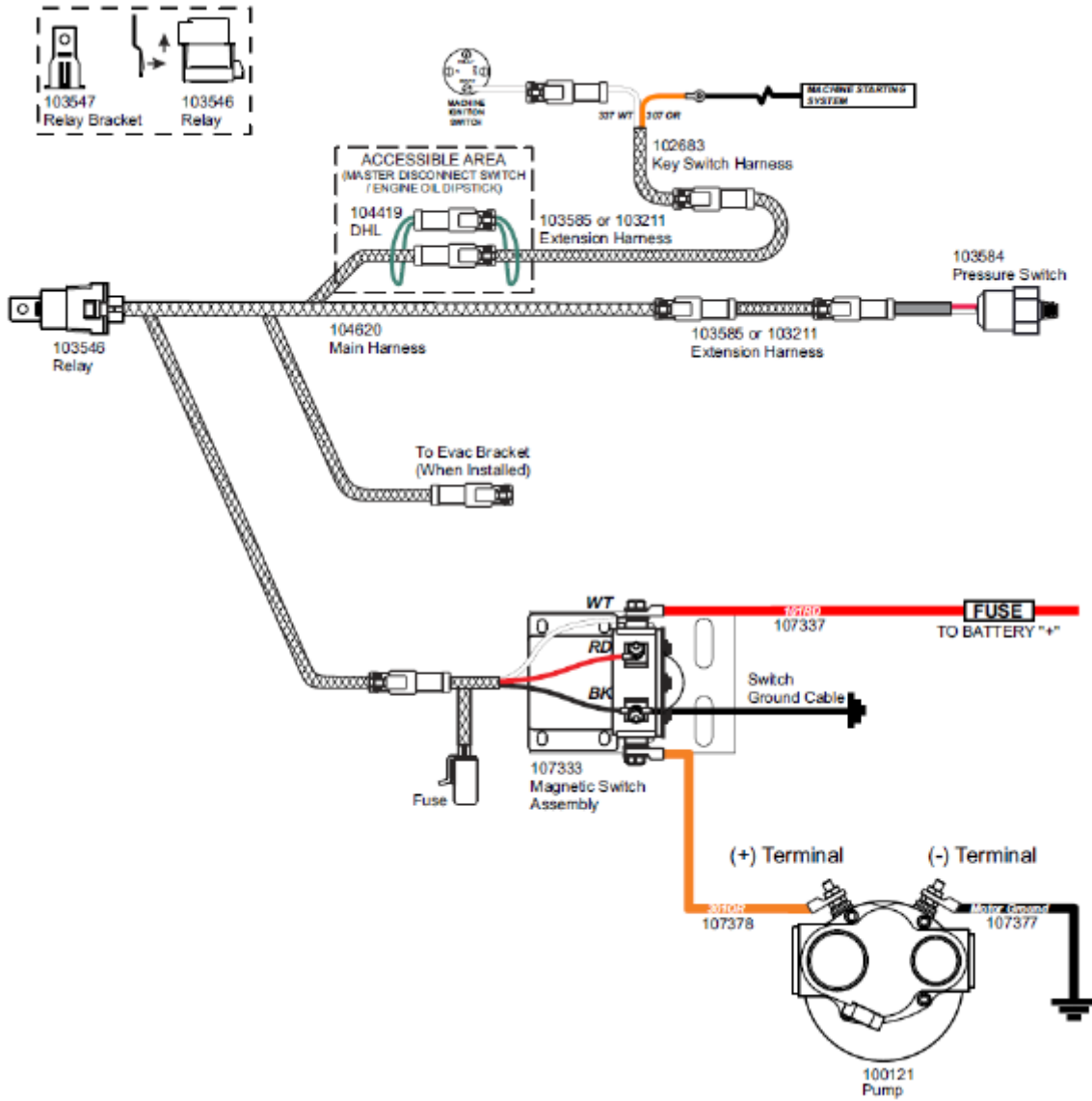

Figure 2. Pre-Lobe Pump Electrical Diagram



**POWER SOLUTIONS
INTERNATIONAL**

**Power Solutions International,
Inc (PSI) 201 Mittel Drive
Wood Dale,
IL 60191 USA
630-350-9400**