



**POWER SOLUTIONS  
INTERNATIONAL**

# **4G Industrial Diagnostic Manual**

**Applicable to PSI Automotive based Industrial Engines with 4G Controllers**

- 2.0L
- 2.4L
- 3.0L
- 4.3L
- 4X/Turbo
- 5.7L
- 6.0L Industrial
- 8.8L

## REVISION CONTROL INFORMATION

Revision	Date	Change Description (s)
1	09/21/2020	Initial release with updated DTC codes 128, 186, 1611,1673, & 1674.
2	01/27/2021	Updated all ignition symptom diagnostics to include weak spark.
3	2/10/2023	Updated 4G Display download location. Updated information for DTC 87 (Fuel pressure low) Updated DTC 128 SPN FMI information which was incorrect previously. Updated Cover. Updated Table of Contents.
4	11/30/2023	Added stationary fuel diagram. Updated DTC 1172 Diagnostic code description.
5	12/18/2023	Updated DTC 128 setting conditions to fix typo.
6	12/15/2024	Updated DTC list and added additional DTCs

REVISION CONTROL INFORMATION .....	2
<b>General Information</b> .....	8
<b>Maintenance</b> .....	11
<b>LPG Fuel System</b> .....	18
<b>Stationary NG or LP Fuel System</b> .....	26
<b>Gasoline Fuel System</b> .....	27
<b>GASOLINE MULTI POINT FUEL INJECTON (3.0L Engine)</b> .....	29
<b>GASOLINE IAFM Manifold (4.3L Engine)</b> .....	31
<b>Fuel System Diagnosis</b> .....	33
<b>FUEL SYSTEM SYMPTOM DIAGNOSTICS</b> .....	37
<b>INTERMITTENT</b> .....	38
<b>NO START</b> .....	39
<b>HARD START</b> .....	41
<b>CUTS OUT, MISSES</b> .....	43
<b>HESITATION, SAG, STUMBLE</b> .....	44
<b>BACKFIRE</b> .....	45
<b>LACK OF POWER, SLUGGISHNESS</b> .....	46
<b>ROUGH, UNSTABLE, OR INCORRECT IDLE</b> .....	47
<b>Electrical Section</b> .....	49
<b>4G Display</b> .....	51
<b>Engine Wire Harness Repair</b> .....	52
<b>4G Diagnostic Trouble Codes (DTCs)</b> .....	57
Malfunction Indicator Lamp (MIL) Operation .....	58
<b>OBD System Check/MIL (Malfunction Indicator Lamp)</b> .....	68
<b>OBD System Check</b> .....	69
<b>Starter Circuit System Diagnostics</b> .....	71
<b>HVS Ignition Control System Diagnostics</b> .....	73
<b>Ignition Control System Diagnostic Chart</b> .....	74
DTC 11 – Distributor Alignment Out of Spec (SPN 520800:FMI 7) .....	76
DTC 16 – Never Crank Synchronized at Start (SPN 636:FMI 8) .....	77
DTC 16- Never Crank Synched At Start (3.0L ONLY) (SPN 636:FMI 8) .....	80
DTC 31 – EGOH1 Open / Ground Short.....	83
DTC 32 – EGOH1 Short to Power .....	85
DTC 51 - EGOH2 Open / Ground Short.....	87
DTC 52 - EGOH2 Short to Power .....	89
DTC 57 EGOH4 Open/Ground Short (SPN 3271:FMI 4) .....	91
DTC 87 – Fuel Pressure Low (SPN 94:FMI 1) .....	94
DTC 88 – Fuel Pressure High (SPN 94:FMI 0) .....	96
DTC 91 – Gasoline Fuel Pressure Sensor Low Voltage (SPN 94:FMI 4) .....	98

DTC 92 – Gasoline Fuel Pressure Sensor High Voltage (SPN 94:FMI 3) .....	99
DTC 107 – MAP Low Voltage (SPN 106:FMI 4) .....	100
DTC 108-MAP High Pressure (SPN 106:FMI 16) .....	104
DTC 111-IAT Higher Than Expected 1 (SPN 105:FMI 15).....	107
DTC 112-IAT Low Voltage (SPN 105:FMI 4) .....	108
DTC 113-IAT High Voltage (SPN 105:FMI 3).....	110
DTC 116-ECT Higher Than Expected 1 (SPN 110:FMI 15) .....	113
DTC 117-ECT/CHT Low Voltage (SPN 110:FMI 4).....	115
DTC 118-ECT/CHT High Voltage (SPN 110:FMI 3).....	117
DTC 121-TPS 1 Lower Than TPS 2 (SPN 51:FMI 1) .....	120
DTC 122-TPS 1 Low Voltage (SPN 51:FMI 4).....	123
DTC 123-TPS 1 High Voltage (SPN 51:FMI 3) .....	126
DTC 127-IAT Higher Than Expected 2 (SPN 105:FMI 0).....	129
DTC 128-Failed to Reach Operating Temperature (SPN 110: FMI 31) .....	130
DTC 129-BP Low Pressure (SPN 108: FMI 1) .....	131
DTC 134-EGO 1 Pre Cat Open/Lazy (SPN 3217:FMI 5).....	135
DTC 148 - Fuel Run-out Longer Than Expected.....	138
DTC 154-EGO 2 Post Cat Open/Lazy (SPN 3227:FMI 5) .....	141
DTC 171-Adaptive Learn High Gasoline (SPN 4237:FMI 0) .....	144
DTC 172-Adaptive Learn Low (Gasoline) (SPN 4237:FMI 1).....	147
DTC 182- Gasoline Fuel Temperature Low (SPN 174:FMI 4).....	149
DTC 183 - Gasoline Fuel Temperature High (SPN 174:FMI 3) .....	150
DTC 186- FT Gaseous Fuel Extremely Low (SPN 3468:FMI 1).....	151
DTC 187 - Fuel Temperature Gaseous Low (SPN 3468 FMI 4).....	152
DTC 188 - FT Gaseous Fuel High (SPN 520240 FMI 3).....	154
DTC 217- ECT Higher Than Expected (SPN 110:FMI 0) .....	156
DTC 219 – Max Govern Speed Override (SPN 515:FMI 15).....	157
DTC 221 – TPS 1 Higher Than TPS 2 (SPN 51:FMI 0).....	159
DTC 222-TPS 2 Signal Voltage Low (SPN 3673:FMI 4) .....	162
DTC 223-TPS 2 Signal Voltage High (SPN 3673:FMI 3).....	165
DTC 236 - TIP/TOP Active .....	168
DTC 237 - TIP/TOP Low Voltage.....	169
DTC 238 - TIP/TOP High Voltage.....	172
DTC 261-Injector Driver 1 (CYL 1) Open or Short to Ground (SPN 651:FMI 5) .....	174
DTC 264-Injector Driver 2 (CYL 6) Open or Short to Ground (SPN 652:FMI 5) .....	175
DTC 267-Injector Driver 183 (CYL 5) Open or Short to Ground (SPN 653:FMI 5).....	176
DTC 270-Injector Driver 184 (CYL 4) Open or Short to Ground (SPN 654:FMI 5).....	177
DTC 273-Injector Driver 5 (CYL 3) Open or Short to Ground (SPN 185:FMI 5) .....	178
DTC 276-Injector Driver 6 (CYL 2) Open or Short to Ground (SPN 186:FMI 5) .....	179
DTC 262-Injector Driver 1 (CYL 1) Coil Shorted (SPN 651:FMI 6) .....	180

DTC 265-Injector Driver 2 (CYL 1) Coil Shorted (SPN 652:FMI 6) .....	181
DTC 268-Injector Driver 3 (CYL 5) Coil Shorted (SPN 653:FMI 6) .....	182
DTC 271-Injector Driver 4 (CYL 4) Coil Shorted (SPN 654:FMI 6) .....	183
DTC 274-Injector Driver 5 (CYL 3) Coil Shorted (SPN 655:FMI 6) .....	184
DTC 277-Injector Driver 6 (CYL 2) Coil Shorted (SPN 656:FMI 6) .....	185
DTC 336-Crank Sync Noise (SPN 636:FMI 2) .....	186
DTC 337-Crank Loss (SPN 636:FMI 4) .....	189
DTC 341-Camshaft Sync Noise (SPN 723:FMI 2) .....	192
DTC 342-Camshaft Sensor Loss (SPN 723:FMI 4).....	195
DTC-359 Fuel Run-out Longer Than Expected (SPN 632:FMI 31) .....	198
DTC 420 Gasoline Catalyst Monitor (SPN 3050:FMI 11) .....	200
DTC 502 – Loss of Road Speed (SPN 84:FMI 8).....	201
DTC 520-Oil Pressure Low Stage 1 (SPN 100:FMI 18) .....	203
DTC 521- Oil Pressure High (SPN 100:FMI 0).....	206
DTC 522- Oil Pressure Sender low voltage (SPN 100:FMI 4).....	208
DTC 523- Oil Pressure Sender high voltage (SPN 100:FMI 3).....	210
DTC 524-Oil Pressure Low Stage 2 (SPN 100:FMI 1) .....	212
DTC 562-System Voltage Low (SPN 168:FMI 17) .....	215
DTC 563-System Voltage High (SPN 168:FMI 15) .....	217
DTC 601-Flash Checksum Invalid (SPN 628:FMI 13).....	219
DTC 604-RAM Failure (SPN 630:FMI 12).....	221
DTC 606-COP Failure (SPN 629:FMI 31).....	223
DTC 627-Fuel Pump Relay Coil Open (SPN 1348:FMI 5).....	225
DTC 628- Fuel Pump Relay Control Ground Short (SPN 1348:FMI 4).....	228
DTC 629- Fuel Pump Relay Coil Short to Power (SPN 1348:FMI 3).....	230
DTC 642-External 5 Volt 1 Reference Low (SPN 1079:FMI 4).....	233
DTC 643-External 5 Volt 1 Reference High (SPN 1079:FMI 3).....	235
DTC 650-MIL Control Open (SPN 1213:FMI 5) .....	237
DTC 652-External 5 Volt 2 Reference Low (SPN 1080:FMI 4).....	240
DTC 653-External 5 Volt 2 Reference High (SPN 1080:FMI 3).....	242
DTC 685-Relay Coil Open (SPN 1485:FMI 5).....	244
DTC 686-Relay Control Ground Short (SPN 1485:FMI 4).....	247
DTC 687-Relay Coil Short to Power (SPN 1485:FMI 3).....	249
DTC 726 - Max Govern Speed Override.....	252
DTC 1111-Fuel Rev Limit (SPN 515:FMI 16).....	254
DTC 1112-Spark Rev Limit (SPN 515: FMI 0) .....	256
DTC 1121 FPP 1 And 2 Redundancy Lost (SPN 91: FMI 31) .....	258
DTC 1151-Closed Loop Multiplier High LPG (SPN 4236:FMI 0) .....	260
DTC 1152-Closed Loop Multiplier Low LPG (SPN 4236:FMI 1).....	263
DTC 1153 - Closed Loop Multiplier High NG .....	265

DTC 1154 - Closed Loop Multiplier Low NG .....	266
DTC 1155-Closed Loop Multiplier High Gasoline (SPN 4236:FMI 0) .....	267
DTC 1156-Adaptive Learn Low (Gasoline) (SPN 4236:FMI 1).....	270
DTC 1161-Adaptive Learn High LPG (SPN 4237:FMI 0) .....	272
DTC 1162-Adaptive Learn Low (LPG) (SPN 4237:FMI 1).....	275
DTC 1163 - Adaptive Learn High NG.....	277
DTC 1164 - Adaptive Learn Low NG .....	278
DTC 1165-LPG Catalyst Monitor (SPN 3050:FMI 11).....	279
DTC 1171-EPR Pressure Higher Than Expected (SPN 520260:FMI 0).....	280
DTC 1172-EPR Pressure Lower Than Expected (SPN 520260:FMI 1).....	282
DTC 354 EPR Pressure Lower than expected (SPN 520260 FMI 1).....	282
DTC 1173-EPR Communication Lost (SPN 520260:FMI 31) .....	284
DTC 1174-EPR Supply Voltage High (SPN 520260:FMI 3) .....	288
DTC 1175-EPR Supply Voltage Low (SPN 520260:FMI 4).....	290
DTC 1176-EPR Internal Actuator Fault (SPN 520260:FMI 12).....	293
DTC 1177-EPR Internal Circuitry Fault (SPN 520260:FMI 12).....	295
DTC 1178-EPR Internal Communication Fault (SPN 520260:FMI 12) .....	297
DTC 1330 - Intake Backfire Detected .....	299
DTC 1351 - Spark Plug or Coil Failure.....	304
DTC 1511-Auxiliary Analog PU 1 High Voltage (SPN 701:FMI 3) .....	305
DTC 1552-Aux Digital 1 Low Voltage (SPN 707:FMI 041) .....	307
DTC 1552: AUX digital 1 low voltage (SPN 520222: FMI 04).....	307
DTC 1611-5VE 1/2 Simultaneous Out of Range (SPN 1079:FMI 31).....	309
DTC 1612-RTI 1 Loss (SPN 629:FMI 31) .....	311
DTC 1613-RTI 2 Loss (SPN 629:FMI 31) .....	313
DTC 1614-RTI 3 Loss (SPN 629:FMI 31) .....	315
DTC 1615-A/D Loss (SPN 629:FMI 31).....	317
DTC 1616-Invalid Interrupt (SPN 629:FMI 31).....	319
DTC 1625- J1939 Shutdown Request (SPN 1100:FMI 31).....	321
DTC 1626- CAN Tx Failure (SPN 639:FMI 12) .....	322
DTC 1627-CAN Rx Failure (SPN 639:FMI 12).....	325
DTC 1628-CAN Address Conflict (SPN 639:FMI 13) .....	328
DTC 1644-MIL Control Ground Short (SPN 1213:FMI 4).....	330
DTC 1645-MIL Control Ground Short To Power (SPN 1213:FMI 3).....	333
DTC 1673-Calibration Configuration Error (SPN 1634:FMI 13).....	336
DTC 1674-Hardware ID Failure (SPN 1634:FMI 2).....	337
DTC 2111-Unable To Reach Lower TPS (SPN 51:FMI 7) .....	338
DTC 2112-Unable To Reach Higher TPS (SPN 51:FMI 7).....	341
DTC 2121-FPP 1 Lower Than FPP 2 (SPN 91:FMI 18) .....	344
DTC 2122-FPP 1 High Voltage (SPN 91:FMI 3) .....	347

DTC 2123-FPP 1 Low Voltage (SPN 91:FMI 4) ..... 350

DTC 2126-FPP 1 Higher Than FPP 2 (SPN 91:FMI 16) ..... 353

DTC 2127-FPP 2 Low Voltage (SPN 29:FMI 4) ..... 356

DTC 2128-FPP 2 High Voltage (SPN 29:FMI 3) ..... 359

DTC 2135-TPS1/2 Simultaneous Voltages Out of Range (SPN 51:FMI 31)..... 362

DTC 2229-BP High Pressure (SPN 108:FMI 0) ..... 365

**Definitions**..... 367

# General Information



## INTRODUCTION

This service manual has been developed to provide the service technician with the basic understanding of the PSI certified fuel and emission systems for PSI supplied engine.

This manual should be used in conjunction with the base engine manual and the OEM service manual when diagnosing fuel or electrical problems.

## SERVICING YOUR EMISSIONS CERTIFIED ENGINE

Any maintenance and repair should be performed by trained and experienced service technicians. Proper tools and equipment should be used to prevent injury to the servicing technician and damage to the vehicle or components. Service repairs should always be performed in a safe environment and the technician should always wear protective clothing to prevent injury.

## FUEL QUALITY

PSI LPG engines and fuel systems are designed to operate on HD-5 or HD-10 specification LPG fuel. Fuel other than HD-5 or HD-10 may cause harm to the engine's emission control system and a warranty claim may be denied on this basis if operators can readily find the proper fuel.

Gasoline engines should use 87 octane or higher. E85 fuel is not permitted for use in the gasoline engine.

Use of any other fuel may result in your engine no longer operating in compliance with CARB or EPA emissions requirements.

## FUEL SYSTEM CAUTIONS

	<b>CAUTION</b>
<b>Do not smoke, carry lighted tobacco, or use a lighted flame of any type when working on or near any fuel related component. Highly flammable air-fuel mixtures may be present and can be ignited causing personal injury</b>	

	<b>CAUTION</b>
<b>Do not allow LPG to contact the skin. LPG is stored in the fuel tank as a liquid. When LPG contacts the atmosphere, it immediately expands into a gas, resulting in a refrigeration effect that can cause severe burns to the skin.</b>	

	<b>CAUTION</b>
<b>Do not allow LPG to accumulate in areas below ground level such as in a service pit or underground ventilation systems. LPG is heavier than air and can displace oxygen, creating a dangerous condition</b>	

	<b>CAUTION</b>
<b>Do not make repairs to the LPG fuel system if you are not familiar with or trained to service LPG fuel system. Contact the dealer who sold you the vehicle to locate a repair facility with trained technicians to repair your fuel system</b>	

## WARNINGS, CAUTIONS AND NOTES

This manual contains several different Warnings, Cautions, and Notes that must be observed to prevent personal injury and or damage to the vehicle, the fuel system or private property.

A "WARNING" is an advisement that by performing a process or procedure listed in this manual improperly may result in serious bodily injury, death and/or serious damage to the vehicle or property.

## PROPER USE OF THIS SERVICE MANUAL, TOOLS AND EQUIPMENT

To reduce the potential for injury to the technician or others and to reduce damage to the equipment during service repairs the technician should observe the following steps:

- The service procedures defined in this manual, when followed, have been found to be a safe and efficient process to repair the fuel system. In some cases, special tools may be required to perform the necessary procedures to safely re-move and replace a failed component.
- The installed PSI fuel system has been certified with the Environmental Protection Agency (EPA) and complies with the regulation in effect at the time of certification. When servicing the fuel and emission control system you should follow all the recommended service and repair procedures to ensure the fuel and emissions system is operating as designed and certified. Purposely or knowingly defeating or disabling any part of the fuel and emission system may be in violation of the anti-tampering provision of the EPA's Clean Air Act.
- Tools identified in this manual with the prefix "J" or "BT" can be procured through SPX in Warren, Michigan.
- Other special tools identified in this manual can be acquired through the equipment OEM or PSI.

### IMPORTANT

It is important to remember that there may be a combination of Metric and Imperial fasteners used in the installation of the PSI fuel system. Check to ensure proper fit when using a socket or wrench on any fastener to prevent damage to the component being removed or injury from "slipping off" the fastener.



## WARNING

**Always leak check any fuel system connection after servicing! Use an electronic leak detector and/or a liquid leak detection solution. Failure to leak check could result in serious bodily injury, death, or serious property damage.**

# Maintenance

## MAINTENANCE

The maintenance of an engine and related components are critical to its operating performance and lifespan. Industrial engines operate in environments that often include hot and cold temperatures and extreme dust. The recommended maintenance schedule is listed in this section; however, environmental operating conditions and additional installed equipment may require more frequent inspection and servicing.

The owner and/or service agent should review the operating conditions of the equipment to determine the inspection and maintenance intervals.

	<b>WARNING</b>
<p>When performing maintenance on the engine, turn the ignition OFF and disconnect the battery negative cable to avoid injury or damage to the engine.</p>	

The engine installed in this equipment uses a drive belt that drives the water pump, alternator and additional pumps or devices. It is important to note that the drive belt is an integral part of the cooling and charging system and should be inspected according to the maintenance schedule in this section. When inspecting the belts check for:

- Cracks
- Chunking of the belt
- Splits
- Material hanging loose from the belt
- Glazing, hardening

If any of these conditions exist, the belt should be replaced with the recommended OEM replacement belt.

### SERPENTINE BELT SYSTEM

Serpentine belts utilize a spring-loaded tensioner to keep the belt properly adjusted. Serpentine belts

should be checked according to the maintenance schedule in this section.

### IMPORTANT:

The use of “belt dressing” or “anti-slipping agents” on belts is not recommended.

### COOLING SYSTEM

It is important that the cooling system of the engine be maintained properly to ensure proper performance and longevity.

	<b>WARNING</b>
<p>Do not remove the cooling system pressure cap (radiator cap) when the engine is hot. Allow the engine to cool and then remove the cap slowly to allow pressure to vent. Hot coolant under pressure may discharge violently.</p>	

Note that there may be an LPG vaporizer connected to the cooling system and the fuel system may be adversely affected by low coolant levels and restricted or plugged radiator cores. Therefore, the cooling system must be maintained according to the recommended maintenance schedule in this section and also include:

- The regular removal of dust, dirt and debris from the radiator core and fan shroud.
- Inspection of coolant hoses and components for leaks, especially at the radiator hose connections. Tighten hose clamps if necessary.
- Check radiator hoses for swelling, separation, hardening, cracks, or any type of deterioration. If any of these conditions exist, the hose should be replaced with a recommended OEM replacement part.
- Inspect the radiator cap to ensure proper sealing.

## COOLANT

The engine manufacturer recommends the cooling system be filled with a 50/50 mixture of antifreeze and water. The use of DexCool "Long Life" type coolant is required. This antifreeze is typically a bright orange in color and should meet the requirements issued by PSI. Coolant should have a minimum boiling point of 300F (149c) and a freezing point no higher than -34F (-37c).

Do not add plain water. Replace coolant per the recommended schedule.

### IMPORTANT:

The manufacturers of the engine and fuel system do not recommend the use of "stop leak" additives to repair leaks in the cooling system. If leaks are present the radiator should be removed and re-paired or replaced.

## ENGINE ELECTRICAL SYSTEM MAINTNANCE

The engine's electrical system incorporates an electronic control module (ECM) to control various related components. The electrical system connections and ground circuits require good connections. Follow the recommended maintenance schedule in this section to maintain optimum performance. When inspecting the electrical system check the following:

- Check Positive and Negative cables for corrosion, rubbing, chafing, burning and to ensure tight connections at both ends.
- Check battery for cracks or damage to the case and replace if necessary.
- Inspect engine wire harness for rubbing, chafing, pinching, burning, and cracks or breaks in the wiring.
- Verify that engine harness connectors are correctly locked in by pushing in and then pulling the connector halves outward.
- Inspect ignition coil wire for hardening, cracking, arcing, chafing, burning, separation, split boot covers.
- Check spark plug wires for hardening, cracking, chafing, arcing or burning, separation, and split boot covers.
- Replace spark plugs at the required intervals per the recommended maintenance schedule.
- Verify that all electrical components are securely

mounted to the engine or chassis.

- Verify that any additional electrical services installed by the owner are properly installed in the system.
- Verify that the MIL, charging, and oil pressure lights illuminate momentarily during engine start.

## ENGINE CRANKCASE OIL

### OIL RECOMMENDATION

It is recommended to use GM Specification GM6094M. To achieve proper engine performance and durability, it is important that you only use engine lubricating oils displaying the American Petroleum Institute (API) "Starburst" Certification Mark 'FOR GASOLINE ENGINES' on the container.



Gasoline engines that are converted to run on LPG or NG fuels must use oils labeled for gasoline engines. Oils specifically formulated for Heavy Duty or Natural Gas Engines are not acceptable.

### IMPORTANT:

Oils recommended by the engine manufacturer already contain a balanced additive treatment. Oils containing "solid" additives, non-detergent oils, or low-quality oils are not recommended by the engine manufacturer. Supplemental additives added to the engine oil are not necessary and may be harmful. The engine and fuel system supplier do not review, approve or recommend such products.

### SYNTHETIC OILS

Synthetic oils have been available for use in industrial engines for a relatively long period of time and may offer advantages in cold and hot temperatures. However, it is not known if synthetic oils provide operational or economic benefits over conventional petroleum-based oils in industrial engines. Use of synthetic oils does not permit the extension of oil change intervals.

### CHECKING/FILLING ENGINE OIL LEVEL

#### IMPORTANT:

Care must be taken when checking engine oil level. Oil level must be maintained between the "ADD" mark and the "FULL" mark on the dipstick.

To ensure that you are not getting a false reading, make sure the following steps are taken before checking the oil level.

1. Stop engine.
2. Allow approximately several minutes for the oil to drain back into the oil pan.
3. Remove the dipstick. Wipe with a clean cloth or paper towel and reinstall. Push the dipstick all the way into the dipstick tube.
4. Remove the dipstick and note the amount of oil on the dipstick. The oil level must be between the "FULL" and "ADD" marks.

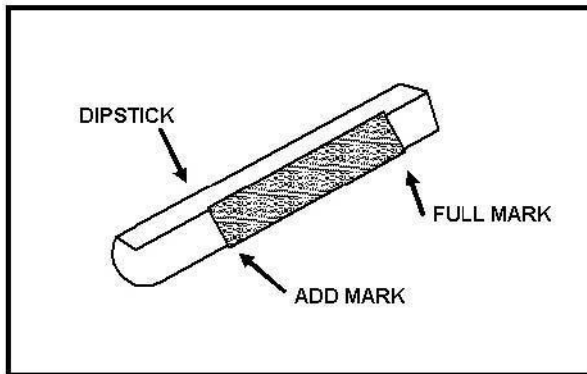

**Figure 2** Engine Oil Dipstick (Typical)

5. If the oil level is below the "ADD" mark reinstall the dipstick into the dipstick tube and proceed to Step 6.
6. Remove the oil filler cap from the valve cover.
7. Add the required amount of oil to bring the level up to, but not over, the "FULL" mark on the dipstick. Reinstall the oil filler cap to the valve rocker arm cover and wipe any excess oil clean.

#### CHANGING THE ENGINE OIL

##### IMPORTANT:

When changing the oil, always change the oil filter.

1. Start the engine and run until it reaches normal operating temperature.

	<h2>CAUTION</h2>
<p><b>An overfilled crankcase (oil level being too high) can cause an oil leak, a fluctuation or drop in oil pressure. When overfilled, the engine crankshafts splash and agitate the oil, causing it to aerate or foam.</b></p>	

##### IMPORTANT:

Change oil when engine is warm and the old oil flows more freely.

2. Stop engine

##### IMPORTANT:

Engine oil will be hot. Use protective gloves to prevent burns. Engine oil contains chemicals which may be harmful to your health. Avoid skin contact.

3. Remove drain plug and allow the oil to drain.
4. Remove and discard oil filter and its sealing ring.
5. Coat sealing ring on the new filter with clean engine oil, wipe the sealing surface on the filter mounting surface to remove any dust, dirt or debris. Tighten filter securely (follow filter manufacturer's instructions). Do not over tighten.
6. Check sealing ring on drain plug for any damage, replace, if necessary, wipe plug with clean rag, wipe pan sealing surface with clean rag and reinstall plug into the pan. Tighten to specification.
7. Fill crankcase with oil.
8. Start engine and check for oil leaks.
9. Dispose of oil and filter in a safe manner.

## FUEL SYSTEM INSPECTION AND MAINTENANCE

### GASOLINE AND LPG FUEL SYSTEM

The fuel system installed on this industrial engine has been designed to meet the mobile engine emission standard applicable for the 2010 and later model years. To ensure compliance to these standards, follow the recommended maintenance schedule contained in this section.

#### INSPECTION AND MAINTENANCE OF THE FUEL STORAGE CYLINDER

The fuel storage cylinder should be inspected daily or at the beginning of each operational shift for any leaks, external damage, adequate fuel supply and to ensure the manual service valve is open. Fuel storage cylinders should always be securely mounted, inspect the securing straps or retaining devices for damage ensure that all locking devices are closed and locked. Check to ensure that the fuel storage cylinder is positioned with the locating pin in the tank collar on all horizontally mounted cylinders this will ensure the proper function of the cylinder relief valve.

When refueling or exchanging the fuel cylinder, check the quick fill valve for thread damage. Also verify O-ring is in place and inspect for cracks, chunking or separation. If damage to the O-ring is found, replace prior to filling. Check the service line quick coupler for any thread damage.

#### IMPORTANT:

When refueling the fuel cylinder, wipe both the female and male connection with a clean rag prior to filling to prevent dust, dirt and debris from being introduced to the fuel cylinder.

#### INSPECTION AND REPLACEMENT OF THE FUEL FILTER

The fuel system on this emission certified engine may utilize an in-line replaceable fuel filter element. This element should be replaced, at the intervals specified in the recommended maintenance schedule. When inspecting the fuel filter check the following:

- Check for leaks at the inlet and outlet fittings, using a soapy solution or an electronic leak detector and repair if necessary.
- Check to make sure filter is securely mounted.
- Check filter housing for external damage or distortion. If damaged replace fuel filter.

#### REPLACING THE FUEL FILTER:

1. Move the equipment to a well-ventilated area and verify that sparks, ignition, and any heat sources are not present.
2. Start the engine.
3. If the engine operates on a positive pressure fuel system, run the engine with the fuel supply closed to remove fuel from the system.

#### IMPORTANT:

A small amount of fuel may still be present in the fuel line. Use gloves and proper eye protection to prevent burns. If liquid fuel continues to flow from the connections when removed, make sure the manual valve is fully closed.

4. Slowly loosen the inlet fitting and disconnect.
5. Slowly loosen the outlet fitting and disconnect.
6. Remove the filter housing from the equipment.
7. Check for contamination.
8. Tap the opening of the filter on a clean cloth.
9. Check for debris.
10. Check canister for proper mounting direction.
11. Reinstall the filter housing to the equipment.
12. Tighten the inlet and outlet fittings to specification.

Check for leaks at the inlet and outlet fittings, and the filter housing end connection using a soapy solution or an electronic leak detector, if leaks are detected make repairs.



## **DIRECT ELECTRONIC PRESSURE REGULATOR (DEPR) MAINTENANCE AND INSPECTION**

### **IMPORTANT:**

The Direct Electronic Pressure Regulator (DEPR) components have been specifically designed and calibrated to meet the fuel system requirements of the emission certified engine.

If the DEPR fails to operate or develops a leak, it should be repaired or replaced with the OEM recommended replacement parts. When inspecting the system check for the following items:

- Check for any fuel leaks at the inlet and outlet fittings.
- Check for any fuel leaks in the IEPR body.
- Check the inlet and outlet fittings of the coolant supply lines for water leaks if applicable.
- Check to ensure the IEPR is securely mounted, and the mounting bolts are tight.
- Check IEPR for external damage.
- Check IEPR electrical connection to ensure the connector is seated and locked.

### **CHECKING/DRAINING OIL BUILD-UP IN THE VAPORIZER REGULATOR**

During the course of normal operation for LPG engines oil or “heavy ends” may build inside the secondary chamber of the Vaporizer Regulator.

These oil and heavy ends may be a result of poor fuel quality, contamination of the fuel, or regional variation of the fuel make up. A significant buildup of oil can affect the performance of the secondary diaphragm response. The Recommended Maintenance Schedule found in this section recommends that the oil be drained at every oil change.

This is the minimum requirement to maintain the emission warranty. More frequent draining of the Vaporizer Regulator is recommended where sub-standard fuel may be a problem. PSI recommends the Vaporizer Regulator be drained at every engine oil change if contaminated or sub-standard fuel is suspected or known to have been used or in use with the emission complaint fuel system. This is known as special maintenance, and failure to follow this recommendation may be used to deny a warranty claim.

### **IMPORTANT:**

Draining the regulator when the engine is warm will help the oils to flow freely from the regulator. To drain the regulator, follow the steps below:

1. Move the equipment to a well-ventilated area and ensure no external ignition sources are present.
2. Start the engine.
3. With the engine running close the manual valve.
4. When the engine runs out of fuel turn OFF the key when the engine stops and disconnect the negative battery cable.

### **IMPORTANT:**

A small amount of fuel may still be present in the fuel line, use gloves to prevent burns, wear proper eye protection. If liquid fuels continue to flow from the connections when loosened check to make sure the manual valve is fully closed.

5. Loosen the hose clamp at the inlet and outlet hoses and remove the hoses.
6. Remove the regulator mounting bolts.
7. Place a small receptacle in the engine compartment.
8. Rotate the regulator to 90° so that the outlet fitting is pointing down into the receptacle and drain the regulator.
9. Inspect the secondary chamber for any large, dried particles and remove.
10. Remove the receptacle and reinstall the regulator retaining bolts and tighten to specifications.
11. Reinstall the fuel hoses.
12. Reconnect any other hoses removed during this procedure.
13. Slowly open the manual service valve.

### **IMPORTANT:**

The fuel cylinder manual valve contains an “Excess Flow Check Valve” open the manual valve slowly to prevent activating the “Excess Flow Check Valve.”

14. Check for leaks at the inlet and outlet fittings using a soapy solution or an electronic leak detector. If leaks are detected make repairs. Check coolant line connections to ensure no leaks are present.
15. Start engine recheck for leaks at the regulator.
16. Dispose of any drained material in safe and proper manner.



## **AIR FUEL MIXER/THROTTLE CONTROL DEVICE MAINTENANCE AND INSPECTION**

### **IMPORTANT:**

The Air Fuel Mixer components have been specifically designed and calibrated to meet the fuel system requirements of the emission certified engine. The mixer should not be disassembled or rebuilt. If the mixer fails to operate or develops a leak the mixer should be replaced with the OEM recommended replacement parts.

When inspecting the mixer check for the following items:

- Leaks at the inlet fitting.
- Fuel inlet hose for cracking, splitting or chaffing, replace if any of these condition exist.
- Ensure the mixer is securely mounted and is not leaking vacuum at the mounting gasket or surface.
- Inspect air inlet hose connection and clamp. Also inspect inlet hose for cracking, splitting or chafing. Replace if any of these conditions exist.
- Inspect Air cleaner element according to the Recommended Maintenance Schedule found in this section.
- Check Fuel lines for cracking, splitting or chafing. Replace if any of these conditions exist.
- Check for leaks at the throttle body and intake manifold.

## **EXHAUST SYSTEM AND CATALYTIC CONVERTER INSPECTION AND MAINTENANCE**

### **IMPORTANT:**

The exhaust system on this emission certified engine contains a Heated Exhaust Gas Oxygen Sensor (HEGO)

which provides feed back to the ECM on the amount of oxygen present in the exhaust stream after combustion.

The oxygen in the exhaust stream is measured in voltage and sent to the ECM. The ECM then makes corrections to the fuel air ratio to ensure the proper fuel charge and optimum catalytic performance. Therefore, it is important that the exhaust connections remain secured and air tight.

### **IMPORTANT:**

The HEGO sensor is sensitive to silicone-based products. Do not use silicone sprays or hoses which are assembled using silicone lubricants. Silicone contamination can cause severe damage to the HEGO.

When inspecting the Exhaust system check the following:

- Exhaust manifold at the cylinder head for leaks and that all retaining bolts and shields (if used) are in place.
- Manifold to exhaust pipe fasteners to ensure they are tight and that there are no exhaust leaks repair if necessary.
- HEGO electrical connector to ensure connector is seated and locked, check wires to ensure there is no cracking, splits chafing or “burn through.” Repair if necessary.
- Exhaust pipe extension connector for leaks tighten if necessary.
- If the engine is equipped with a catalytic converter inspect the converter to ensure it is securely mounted.
- Check for any leaks at the inlet and outlet of the converter.

# LPG Fuel System

# MOBILE ENGINE LPG FUEL SYSTEM SCHEMATIC

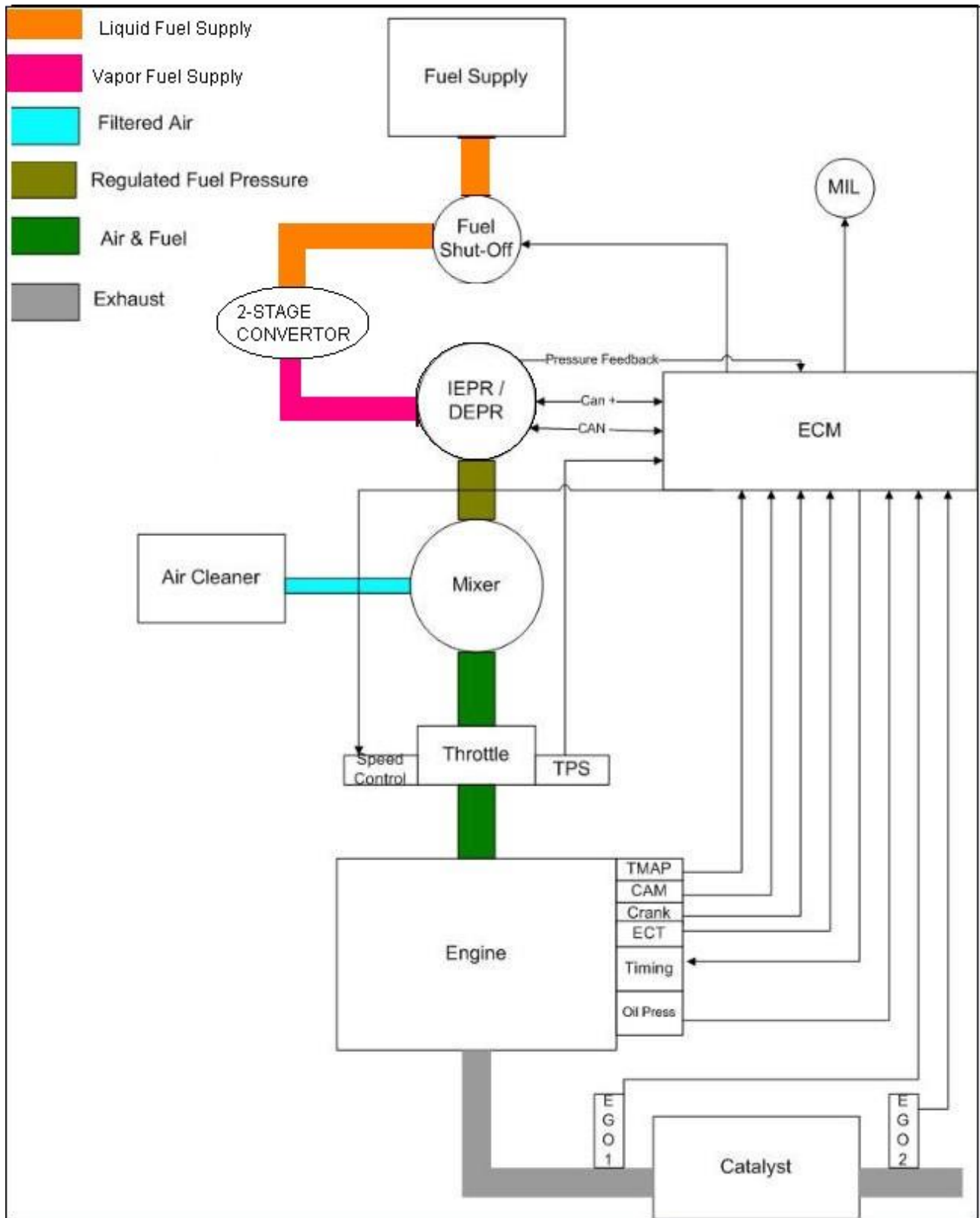

## DESCRIPTION AND OPERATION OF THE FUEL SYSTEMS

### NG & LPL FUEL SYSTEM

The primary components of the fuel system are the fuel supply, direct electronic pressure regulator (DEPR), fuel mixer, electronic throttle control (ETC) device, 2-Stage convertor, engine control module (ECM), and a catalytic converter. The system operates on a slightly positive fuel pressure. Primary fuel pressure can be measured at the LD 2-Stage converter. Secondary fuel pressure command and actual fuel pressure is monitored by the ECM. You can view these pressures using the diagnostic service tool.

### SERVICE LINES

Fuel flows from the fuel supply to the electric lock off valve. The service lines are not supplied by the engine manufacturer. Please contact the equipment manufacturer regarding fuel service lines

### FUEL FILTER

LP, fuel like all other motor fuels is subject to contamination from outside sources. Refueling of the equipment tank and removal of the tank from the equipment can inadvertently introduce dirt and other foreign matter into the fuel system. It is therefore necessary to filter the fuel prior to entering the fuel system components downstream of the tank. An inline fuel filter has been installed in the fuel system to remove the dirt and foreign matter from the fuel, which is replaceable as a unit only. Maintenance of the filter is critical to proper operation of the fuel system and should be replaced according to the maintenance schedule or more frequently under severe operating conditions.

#### Inline Fuel Filter

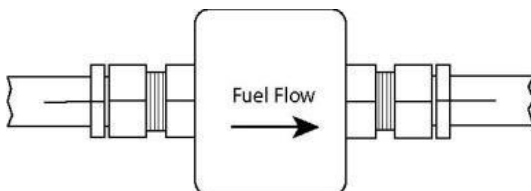

### ELECTRIC FUEL LOCK-OFF VALVE

The Electric Fuel lock-off valve is an integrated assembly consisting of a 12-volt solenoid and a normally closed valve. When energized, the solenoid opens the valve and allows the fuel to flow through the device. The valve opens during cranking and the engine run cycles.

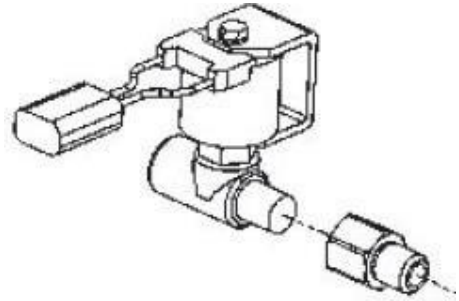

### ELECTRIC FUEL LOCK-OFF

Voltage to the Electric Lock-Off Valve is controlled by the engine control module (ECM).

### DIRECT ELECTRONIC PRESSURE REGULATOR (DEPR)

The ECI engine management system uses the DEPR to control fuel delivery for the precise fuel metering necessary for optimum combustion, fuel economy and transient response. The DEPR is available in either a 19 or a 28 mm size.

The DEPR is a single-stage microprocessor based electromechanical fuel pressure regulator that incorporates a high speed/fast acting actuator. It communicates with the Engine Control Module (ECM) over a Controller Area Network (CAN) link, receiving fuel pressure commands and broadcasting DEPR operating parameters back to the ECM. The DEPR can regulate fuel pressure from -18 to +13 inches of water column above the Mixer air inlet pressure, providing sufficient control authority to stall an engine either rich or lean. When the DEPR receives an output pressure command from the ECM, the valve is internally driven to attain targeted.

fuel pressure, the DEPR then closes the loop internally using a built-in fuel pressure sensor to maintain target fuel pressure/fuel flow rate, until another external command from the ECM is received (intervals < 10 ms). The DEPR has an integral fuel temperature sensor that is used by the ECM to correct for variations in fuel density. This strategy provides an extremely accurate method for open loop fuel control. Then with the addition of the pre- and post-cat oxygen sensors, the pressure command transmitted from the ECM can be further adjusted using closed loop feedback.



**Direct Electronic Pressure Regulator**

in the air valve assembly. A pressure/force imbalance begins to build across the air valve diaphragm between the air valve vacuum chamber and the atmospheric pressure below the diaphragm. The vacuum being created is referred to as Air Valve Vacuum (AVV). As the air valve vacuum reaches the imbalance point, the air valve begins to lift against the air valve spring. The amount of AVV generated is a direct result of the throttle position. At low engine speed the air valve vacuum and the air valve position is low thus creating a small venturi for the fuel to flow. As the engine speed increases the AVV increases, and the air valve is lifted higher thus creating a much larger venturi. This air valve vacuum is communicated from the mixer venturi to the IEPR via the fuel supply hose.

The mixer is equipped with a low-speed mixture adjustment retained in a tamper proof housing. The mixer has been preset at the factory and should not require adjustment. In the event that the idle adjustment should need to be adjusted refer to the Fuel System Repair section of this manual.

	CAUTION
<p>The IEPR is an emission control device and should only be serviced by qualified technicians.</p>	

	CAUTION
<p>The air/fuel mixer is an emission control device. Components inside the mixer are specifically calibrated to meet the engine's emissions requirements and should never be disassembled or rebuilt. If the mixer fails to function correctly, replace with an OEM replacement part.</p>	

**AIR FUEL MIXER**

The air valve mixer is a self-contained air-fuel metering device. The mixer is an air valve design, utilizing a relatively constant pressure drop to draw fuel into the mixer from cranking speeds to full load. The mixer is mounted in the air stream ahead of the throttle control device.

When the engine begins to crank it draws in air with the air valve covering the inlet, and negative pressure begins to build. This negative pressure signal is communicated to the top of the air valve chamber through vacuum ports



**Air Valve Mixer**

**Light Duty 2-Stage Vaporize**

The tier 3 certified mobile products utilize a 2-stage vaporizer as part of the fuel system. The primary function of this part is to convert liquid LP fuel into a propane vapor. The vapor is then introduced into the DEPR where the pressures are regulated. Con-verting the fuel from a liquid to a vapor is accomplished by passing the propane through a heat exchanger inside the convertor. Coolant flows through the convertor as part of the heat exchange process.

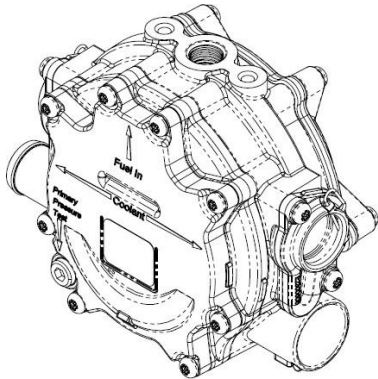

***LD 2-Stage Vaporizer***

**ELECTRONIC THROTTLE CONTROL DEVICE (ETC)—**

Engine speed is controlled by the ECM and the Electronic Throttle Control device which is an automotive style throttle. The ECM controls engine speed one of several ways depending on the equipment manufacturer's requirement. Engine speed can be controlled by discrete speed governing, whereby the OEM sends an open, high or low voltage signal to an ECM pin. The ECM then targets the preprogrammed speed for that pin.

The other two modes are through the use of a foot pedal or a hand throttle controller. In both cases the foot pedal or hand throttle controller will send a 0–5-volt signal to the ECM. The ECM is programmed with an idle and high speed and interprets speed in between the two based on voltage.

When the engine is running electrical signals are sent from the foot pedal position sensor to the engine ECM

when the operator depresses or release the foot pedal. The ECM then sends an electrical signal to the motor on the electronic throttle control to increase or decrease the angle of the throttle blade thus increasing or decreasing the air/fuel charge to the engine. The electronic throttle control device incorporates two internal Throttle Position Sensors (TPS) which provide output signals to the ECM as to the location of the throttle shaft and blade. The TPS information is used by the ECM to correct for speed and load control as well as emission.

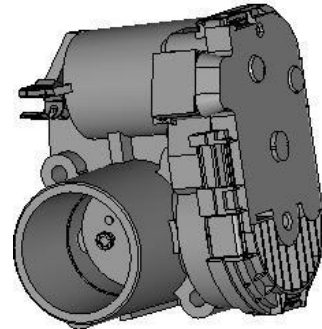

***Electronic Throttle Control Device***

**THREE-WAY CATALYTIC CONVERTER**

The Catalytic Converter is a component of the emissions system which is designed to meet the emission standards in effect for the Tier 3 mobile certified product.

The exhaust gases pass through the honeycomb catalyst which is coated with a mixture of precious group metals to oxidize and reduce CO, HC and NOX emission gases.

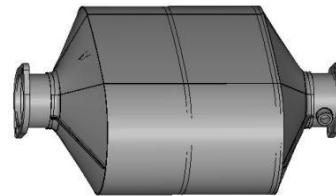

***Three Way Catalytic Converter***

## ENGINE CONTROL MODULE

To obtain maximum effect from the catalyst and accurate control of the air fuel ratio, the emission certified engine is equipped with an onboard computer or Engine Control Module (ECM). The ECM is a 32-bit controller which receives input data from sensors mounted to the engine and fuel system and then outputs various signals to control engine operation.

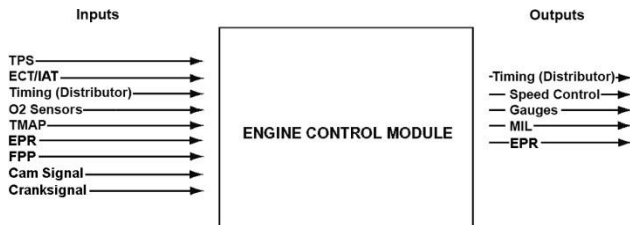

### Engine Control Module (ECM)

One specific function of the controller is to maintain a closed loop fuel control which is accomplished by use of the Heated Exhaust Gas Oxygen sensor (HEGO) mounted in the exhaust system. The HEGO sensor sends a voltage signal to the controller which then outputs signal to the EPR to change the amount of fuel being delivered from the regulator or mixer to the engine.

The controller also performs diagnostic functions on the

fuel system and notifies the operator of engine malfunctions by turning on a Malfunction Indicator Light (MIL) mounted in the dash. Malfunctions in the system are identified by a Diagnostic Trouble Code (DTC) number. In addition to notifying the operator of the malfunction in the system, the controller also stores the information about the malfunction in its memory. A technician can then utilize a computerized diagnostic scan tool to retrieve the stored diagnostic code and by using the diagnostic charts in this manual to determine the cause of the malfunction. In the event a technician does not have the computerized diagnostic tool, the MIL light can be used to identify the diagnostic code to activate the “blink” feature and count the number of blinks to determine the diagnostic code number to locate the fault in the system.

### HEATED EXHAUST GAS OXYGEN SENSORS

The Heated Exhaust Gas Oxygen (HEGO) Sensors are mounted in the exhaust system, one upstream and one downstream of the catalytic converter. Models that do not use a catalyst assembly will only use one HEGO sensor.

The HEGO sensors are used to measure the amount of oxygen present in the exhaust stream to determine whether the air-fuel ratio is too rich or too lean. It then communicates this measurement to the ECM. If the HEGO sensor signal indicates that the exhaust stream is too rich, the ECM will decrease or lean the fuel mixture during engine operation. If the mixture is too lean, the ECM will richen the mixture. If the ECM determines that a rich or lean condition is present for an extended period of time which cannot be corrected, the ECM will set a diagnostic code and turn on the MIL light in the dash.

By monitoring output from the sensor upstream and the sensor downstream of the catalytic converter, the ECM can determine the performance of the catalyst.

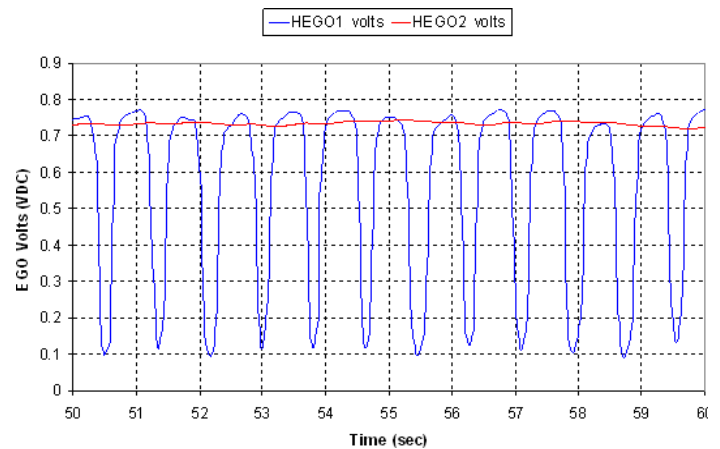



**The Heat Exhaust Gas Oxygen (HEGO) Sensor**

*HEGO1 (upstream or before the catalytic converter) and HEGO2 (downstream) voltage output.*

## CAUTION

The Heated Exhaust Gas Oxygen Sensor (HEGO) is an emissions control component. In the event of a failure, the HEGO should only be replaced with the recommended OEM replacement part. The HEGO is sensitive to silicone-based products and can become contaminated. Avoid using silicone sealers or air or fuel hoses treated with a silicone based lubricant.

**TMAP SENSOR**

The Temperature Manifold Absolute Pressure or TMAP sensor is a variable resistor used to monitor the difference in pressure between the intake manifold and outside or atmospheric pressure and the temperature. The ECM monitors the resistance of the sensor to determine engine load (the vacuum drops when the engine is under load or at wide open throttle). When the engine is under load, the computer may alter the fuel mixture to improve performance and emissions. The ECM also monitors the temperature, primarily to richen the fuel/air mixture during a cold start.

**COOLANT TEMPERATURE SENSOR**

The Engine Coolant Temperature sensor or ECT is a variable resistance thermistor that changes resistance as the engine's coolant temperature changes. The sensor's output is monitored by the ECM to determine a cold start condition and to regulate various fuel and emission control functions via a closed loop emission system.

**OIL PRESSURE SENDER**

The Engine Oil Pressure sensor is designed to ensure adequate lubrication throughout the engine. It provides a pressure value for the oil pressure gauge and is monitored by the ECM. If the pressure drops, an MIL will occur.

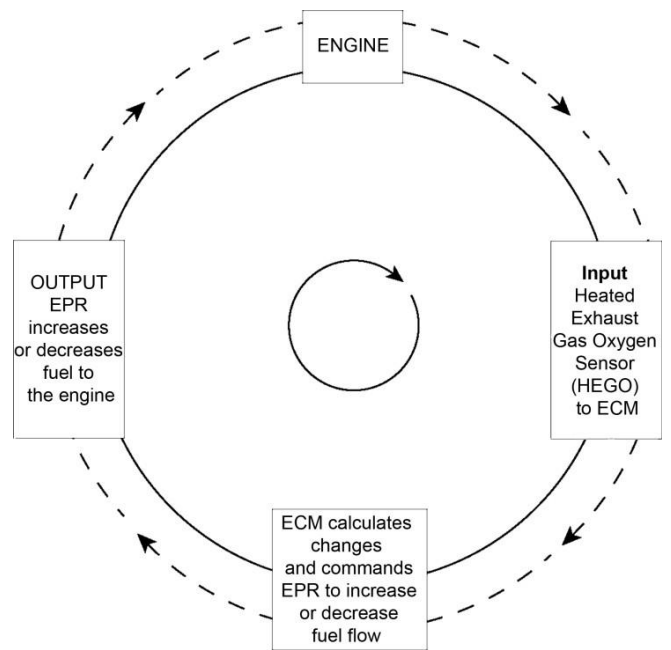

**Closed-Loop Fuel Control**

**LD 2-Stage Regulator Nominal Pressure Specifications**

Secondary Stage	15.25 ±10 inches H2O
Primary Stage	2.6 ±1.45PSI



## Engine Control Module (ECM) vs Integrated Electronic Pressure Regulator (IEPR)

For different engine platforms and sizes, the Engine Control Module (ECM) may either be a dedicated unit or integrated into the Integrated Electronic Pressure Regulator (IEPR). Regardless of the configuration, whether it's a standalone ECM or one integrated with the electronic pressure regulator, the operating software and the underlying principles remain consistent.

The integrated ECM, when part of the IEPR, generally offers reduced functionality and capabilities. This integration is typically more suitable for smaller, stationary engine products, where the demands on the ECM are less extensive. This design choice balances the need for control and efficiency with the scale and complexity of the engine system

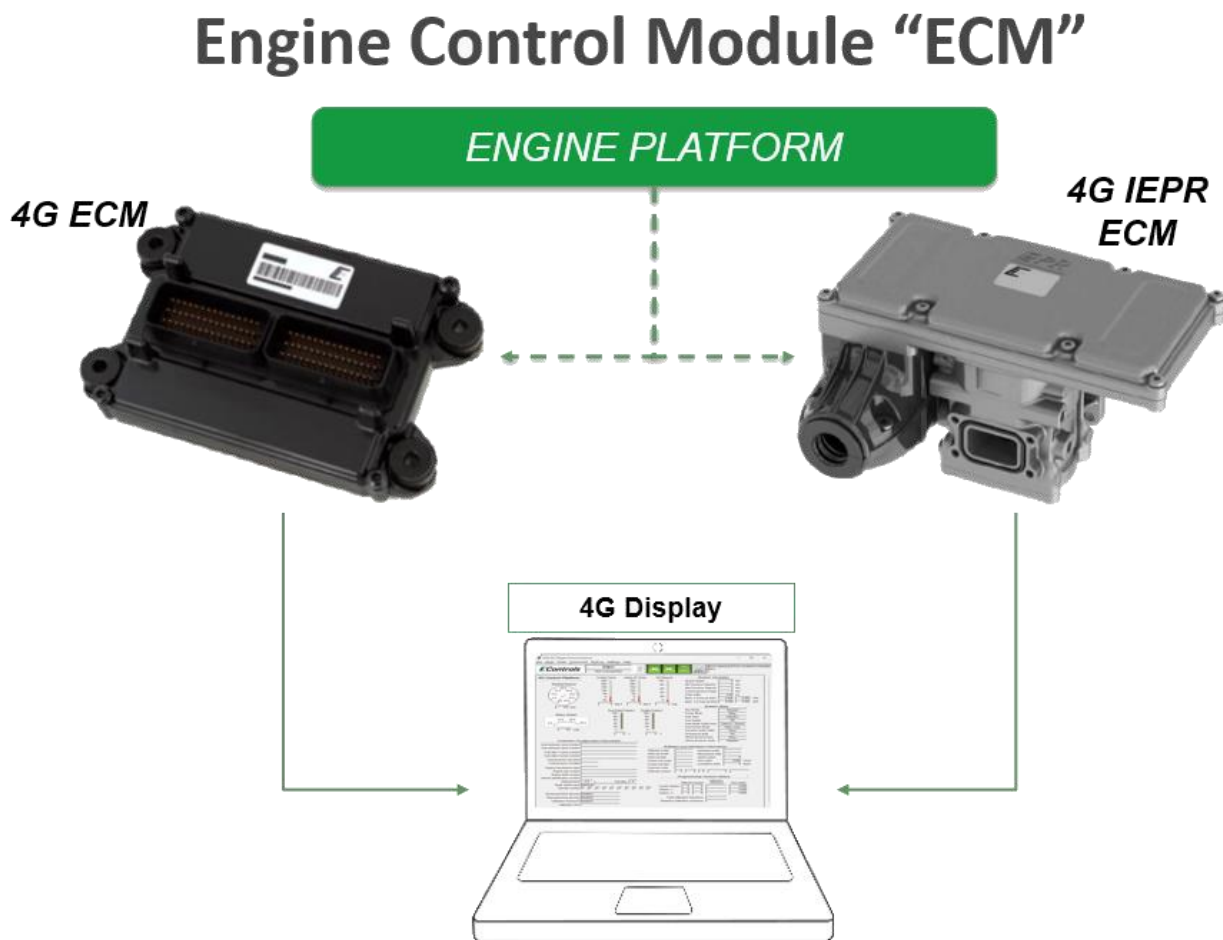

# Stationary NG or LP Fuel System

PSI Stationary Industrial Engines can generally run on EITHER Natural Gas OR Propane Fuel.

Required fuel pressure into the IEPR or EPR is 7 to 11 Inches of Water Column (7" WC) during all load conditions.

The engine needs to know which fuel to run on, this is accomplished by utilizing the "Fuel Select" circuit in the customer interface connector.

The fuel system, engine control system, and ignition system **does not require modification** when changing switching between NG or Propane fuel types.

- Except for what is noted above regarding the "**Fuel Select**" circuit

All PSI engines (except for gasoline or diesel) require the fuel to enter the engine as "gaseous" fuel.

- Our engines do not **directly** run on liquid propane
- If the application is using liquid propane as the fuel source, **the liquid MUST be converted to a vapor**

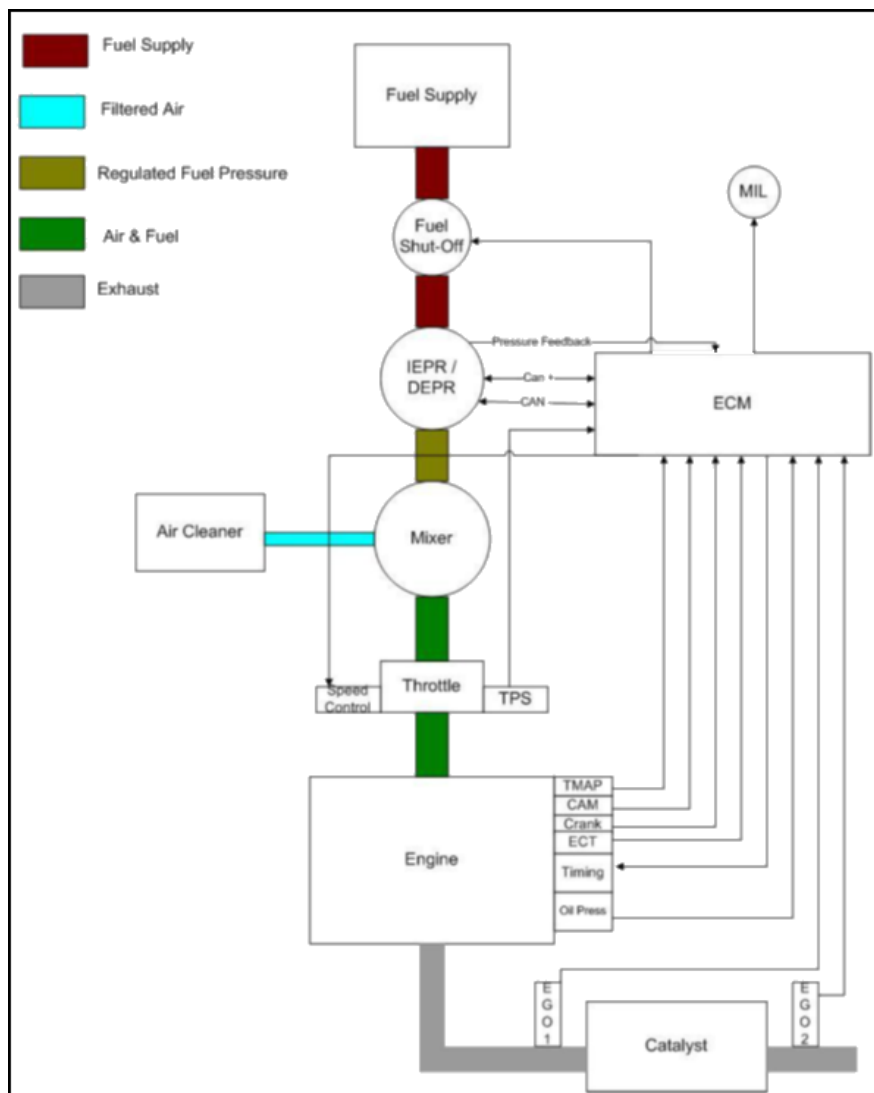

# Gasoline Fuel System

# MOBILE ENGINE GASOLINE FUEL SYSTEM SCHEMATIC

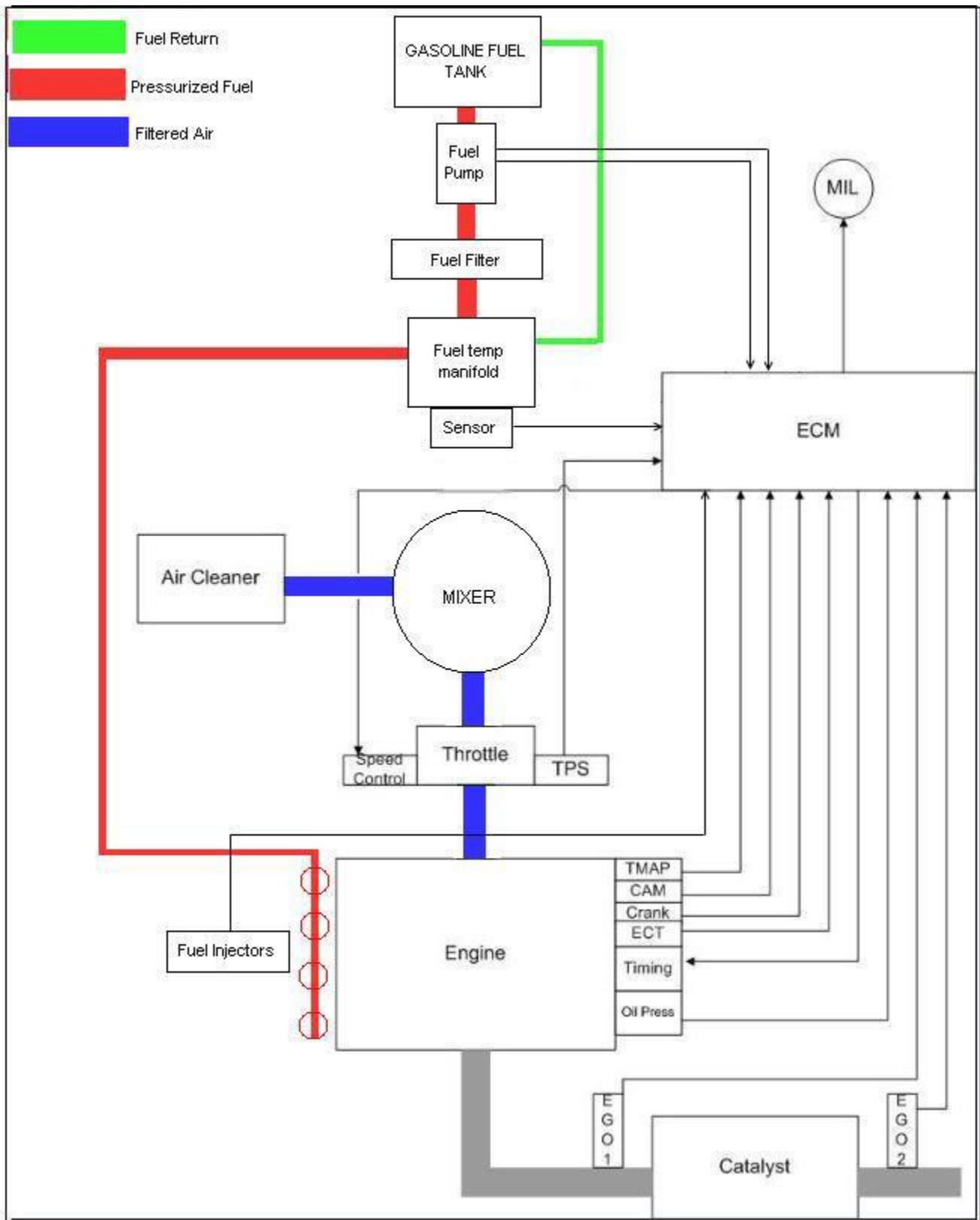

## GASOLINE MULTI POINT FUEL INJECTON (3.0L Engine)

The primary components of the Gasoline Multi Point Fuel Injection (MPFI) fuel system are the gasoline fuel tank, electric fuel pump, fuel pressure and temperature sensor manifold, fuel filter and fuel rail.

### GASOLINE FUEL STORAGE TANK

The gasoline fuel storage tank location may vary on equipment applications. The fuel tank may be integrated into the chassis frame or may be a standalone vessel mounted on the equipment. For precise location for the equipment application refer to the OEM's vehicle manual.

### GASOLINE FUEL PUMP

The Gasoline is stored as a liquid in the fuel tank and is drawn into the fuel system by a 12-volt electric fuel pump. Depending on the vehicle application the fuel pump may be mounted in the fuel tank or as a standalone component. In either case the fuel pump will receive a signal from the ECM at Key On to prime the fuel system for approximately 2 seconds prior to start. Priming of the fuel system provides for a quicker start when the engine begins to crank. Consult the OEM for the location of the fuel pump.

### GASOLINE PRESSURE AND TEMPERATURE SENSOR MANIFOLD

This engine is equipped with a fuel injector rail that does not have a pressure regulator or a return circuit to the fuel tank. Fuel pressure for this engine is regulated by the engine's ECM. The ECM receives fuel pressure and temperature feedback from the gasoline fuel sensor manifold and uses this information to control the ground side of the fuel pump. Fuel pressure is regulated by the ECM pulse width modulating (PWM) the fuel pump. The fuel pressure and temperature sensor manifold has a return or "bleed" circuit that connects back to the equipment fuel tank. This circuit is used to bleed off any vapor that develops in the line and returns a small amount of fuel to the tank. The fuel comes from the fuel tank and passes through the fuel pump. Fuel exits the fuel pump, passes through the filter, and then enters the fuel pressure and temperature manifold assembly. Fuel flows through the feed circuit and is delivered to the fuel injector rail. Fuel that enters the bleed circuits through the by-pass valve in the manifold is returned to the fuel tank.

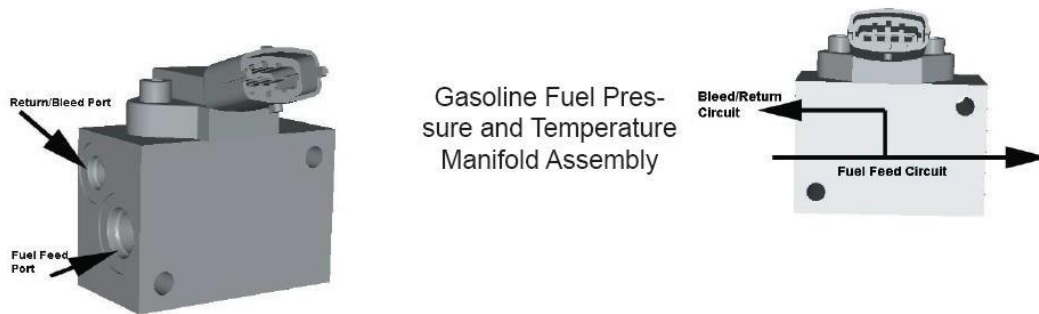

### FUEL FILTER

After the fuel is drawn into the fuel pump, the fuel flows through the gasoline fuel filter. The fuel filter will trap small particles. The fuel passes through the filter to remove debris which prevents the fuel pressure and temperature manifold and fuel injectors from becoming damaged. Maintenance of the fuel filter is required as indicated in the Recommended Maintenance Schedule. A more frequent replacement of the filter may be required if the equipment operates in a dusty or dirty environment.

## FUEL INJECTOR RAIL

The fuel flows from the fuel pressure and temperature manifold assembly to the fuel rails where the fuel is delivered to the fuel injectors. The fuel rail also contains a Schrader valve which is utilized to test the regulated pressure of the fuel system.

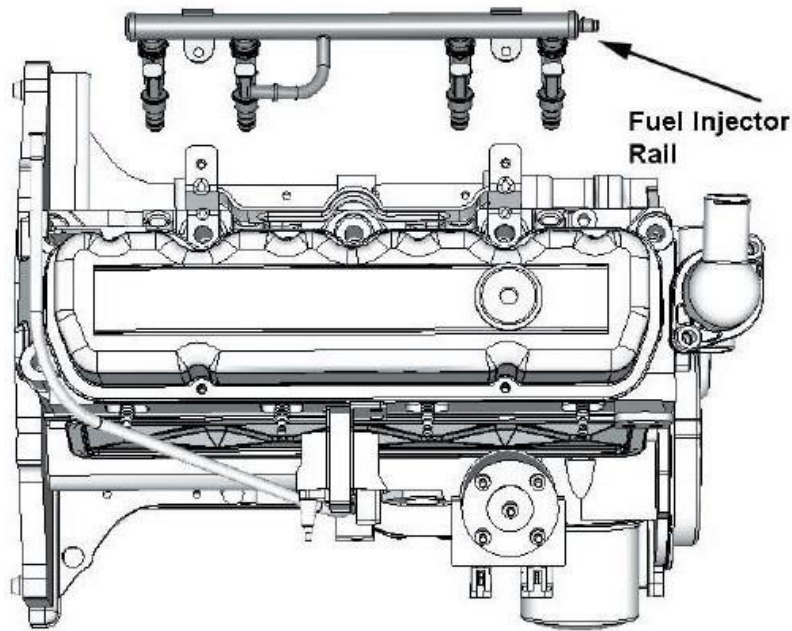

## FUEL INJECTOR

The fuel supply is maintained on the top of the injector from the injector rail. The injector is fed a “pulse” signal through the wire harness which causes the injector to open. During regular operating conditions the ECM controls the opening and duration of opening of the injector. During lower RPM operation the injector signals or “pulses” are less frequent than when the engine is operating at higher RPMs. The certified engine has been calibrated to deliver the precise amount of fuel for optimum performance and emission control.

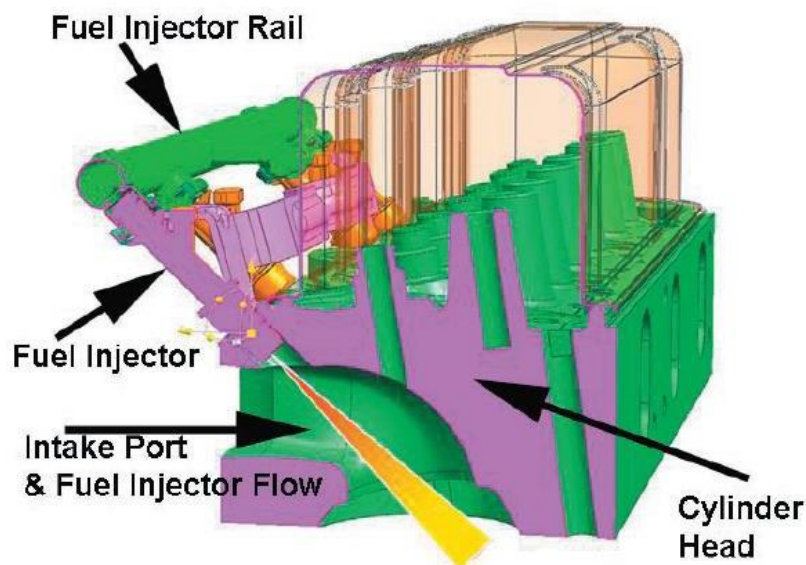

## GASOLINE IAFM Manifold (4.3L Engine)

The primary components of the Gasoline IAFM fuel system are the gasoline fuel tank, electric fuel pump, fuel pressure and temperature sensor manifold, Intake manifold, and IAFM.

### GASOLINE FUEL STORAGE TANK

The gasoline fuel storage tank location may vary on equipment applications. The fuel tank may be integrated into the chassis frame or may be a standalone vessel mounted on the equipment. For precise location for the equipment application refer to the OEM's vehicle manual.

### GASOLINE FUEL PUMP

The Gasoline is stored as a liquid in the fuel tank and is drawn into the fuel system by a 12-volt electric fuel pump. Depending on the vehicle application the fuel pump may be mounted in the fuel tank or as a standalone component. In either case the fuel pump will receive a signal from the ECM at Key On to prime the fuel system for approximately 2 seconds prior to start. Priming of the fuel system provides for a quicker start when the engine begins to crank. Consult the OEM for the location of the fuel pump.

### GASOLINE PRESSURE AND TEMPERATURE SENSOR MANIFOLD

This engine is equipped with a fuel injector rail that does not have a pressure regulator or a return circuit to the fuel tank. Fuel pressure for this engine is regulated by the engine's ECM. The ECM receives fuel pressure and temperature feedback from the gasoline fuel sensor manifold and uses this information to control the ground side of the fuel pump. Fuel pressure is regulated by the ECM pulse width modulating (PWM) the fuel pump. The fuel pressure and temperature sensor manifold has a return or "bleed" circuit that connects back to the equipment fuel tank. This circuit is used to bleed off any vapor that develops in the line and returns a small amount of fuel to the tank. The fuel comes from the fuel tank and passes through the fuel pump. Fuel exits the fuel pump, passes through the filter, and then enters the fuel pressure and temperature manifold assembly. Fuel flows through the feed circuit and is delivered to the fuel injector rail. Fuel that enters the bleed circuits through the by-pass valve in the manifold is returned to the fuel tank.

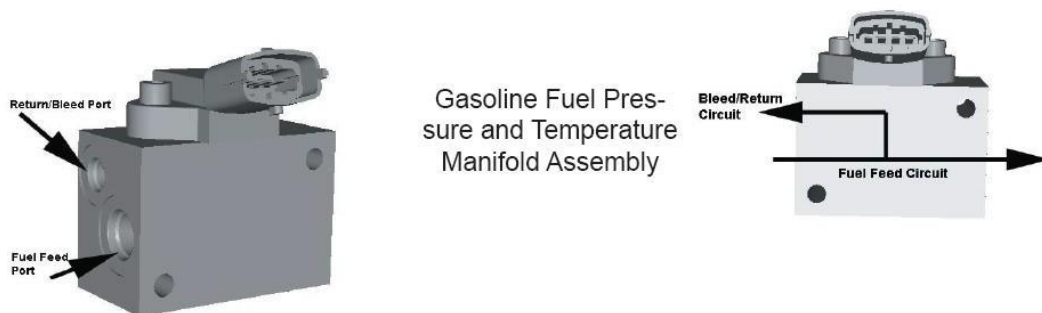

### FUEL FILTER

After the fuel is drawn into the fuel pump, the fuel flows through the gasoline fuel filter. The fuel filter will trap small particles. The fuel passes through the filter to remove debris which prevents the fuel pressure and temperature manifold and fuel injectors from becoming damaged. Maintenance of the fuel filter is required as indicated in the Recommended Maintenance Schedule. A more frequent replacement of the filter may be required if the equipment operates in a dusty or dirty environment.



## IAFM Intake Manifold

IAFM is the acronym for Intake Air Fuel Module. This style intake manifold incorporates the air intake manifold and gasoline fuel delivery system into one module. The IAFM is used on the 4.3L GM engine.

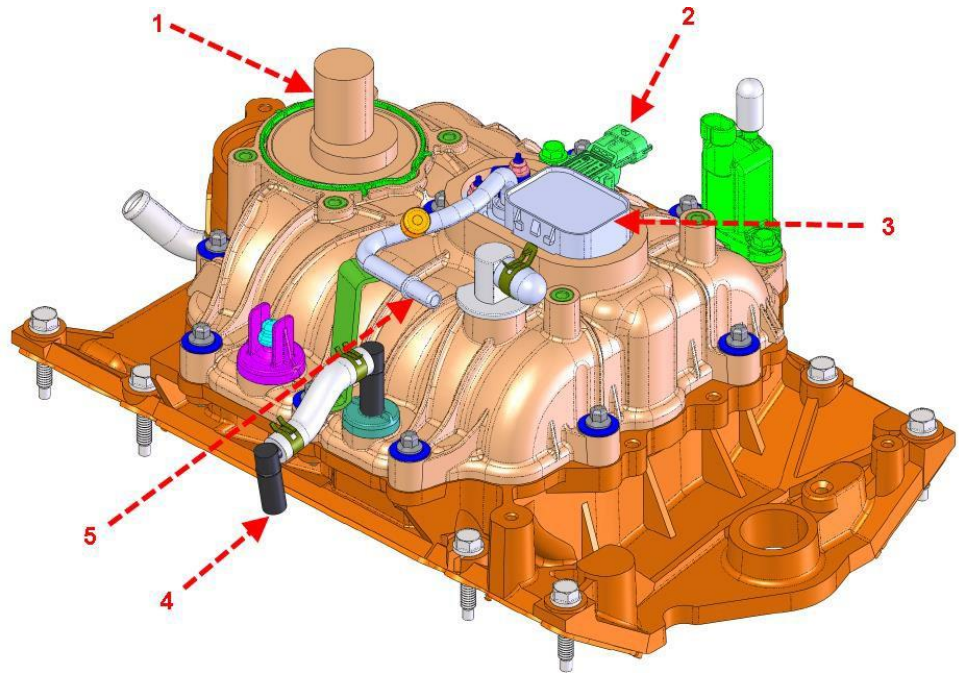

- 1) Throttle Body Location
- 2) MAP Sensor
- 3) Fuel Injector Connector
- 4) PCV Circuit
- 5) Fuel Inlet Connection

## Fuel Injectors

The IAFM system uses one fuel injector per cylinder. The injectors are routed to each intake port internally as shown in number 7. The nominal fuel pressure is typically in the range of 74 psia.

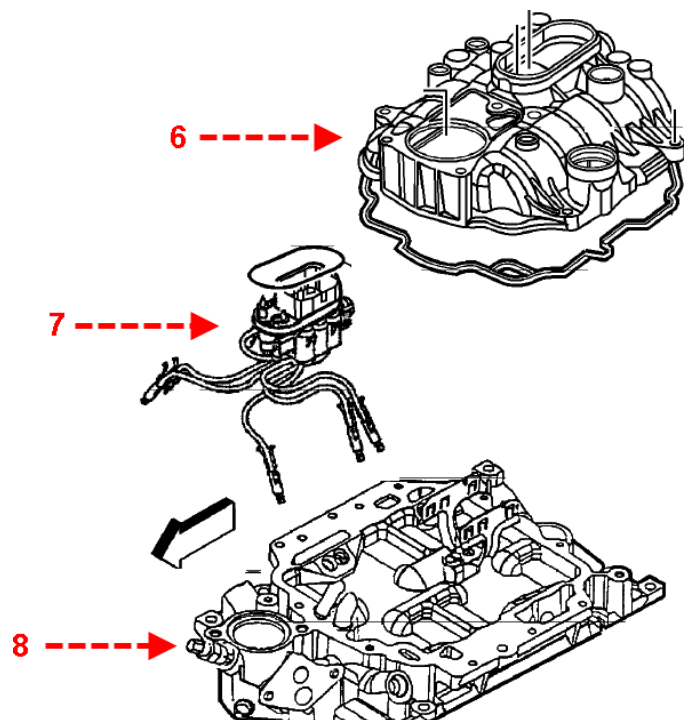

- 6) Upper Intake
- 7) Fuel Injectors
- 8) Lower Intake



# Fuel System Diagnosis

## FUEL SYSTEM DIAGNOSIS



*Direct Electronic Pressure Regulator Assembly*

### FUEL SYSTEM DESCRIPTION

The Engine Control Module (ECM) receives information from various engine sensors in order to control the operation of the Direct Electronic Pressure Regulator (DEPR) and lock-off Valve.

The lock-off Valve solenoid prevents fuel flow unless the engine is cranking or running.

At Key ON, the DEPR valve receives a two (2) second prime pulse from the ECM, allowing time for the fuel to flow through the fuel filter and fuel lines to the DEPR.

Fuel travels from the lock-off to the light duty 2- stage regulator into the DEPR.

Engine cranking generates vacuum which provided lift for the mixer air valve and is commonly referred to as air valve vacuum. Once in the mixer, the fuel is combined with air and is drawn into the engine for combustion.

### DIAGNOSTIC AIDS

If the equipment will not continue to run, refer to Hard Start for preliminary checks.

- Inspect the fuel supply lines to verify they are properly connected and do not have any kinks or damage.
- Verify the fuel lock off valve is operating properly. Refer to the OEM for information on the fuel shut off valve.

### TOOLS REQUIRED:

#### DST

- Diagnostic Scan Tool (DST)

### PRESSURE GAUGES

- ITK-2 Test Kit

## TEST DESCRIPTION

The basis of the fuel system test is to determine if the fuel is operating within proper fuel control parameters. This fuel control system operates on the basis of short term and long-term fuel correction to compensate for the normal operation and aging of the engine. Abnormal operation of the engine, due to a component issue or lack of maintenance will cause fuel system control parameters to operate outside of the normal range.

The fuel system correction factors are viewable using the laptop based Diagnostic Service Tool (DST).

The short-term correction factor is a percentage-based fuel correction that will immediately be applied once the engine reaches the closed loop fuel control mode. The short-term correction factor is known as “Closed Loop 1” on the DST.

The long-term correction factor writes the short-term correction into long term memory so it is available immediately on the next start/run cycle. The long-term correction factor is known as “Adaptive 1” on the DST.

Closed Loop 1 and Adaptive 1 can be viewed on the Closed Loop Control panel on the Faults Page of the DST.

## HOW THE CORRECTION FACTORS WORK

The correction factors are displayed in the DST as a positive or negative percent. The numbers will range between -35% and +35%. A negative fuel correction number indicates the removal of fuel.

An outside condition causing the system to be rich, such as a restricted air cleaner, can cause a negative short term and long-term fuel correction. An outside condition causing the system to be lean, such as a vacuum leak, can cause a positive fuel correction.

## DETERMINING TOTAL FUEL CORRECTION

The total fuel correction is the sum of the short-term correction (Closed Loop 1) and the long-term correction (Adaptive 1).

For instance, a Closed Loop 1 reading of -1.5% and an Adaptive 1 reading of -3.5% would mean a total fuel correction of -5% was taking place at that time. The system is removing 5% fuel at that time.

A Closed Loop 1 reading of 1.5% and an Adaptive 1 reading of 3.5% (note both are positive numbers) would mean that a total fuel correction of 5% was taking place at that time. The system is adding 5% fuel.

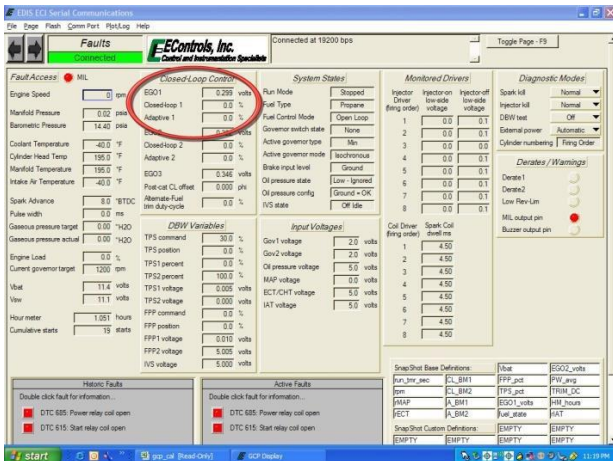

### Closed Loop 1 & Adaptive 1

Any parameter found to be out of conformance will require additional diagnosis.

## NORMAL & ABNORMAL FUEL CORRECTION

Generally, the system is operating within specification when total fuel correction falls between -15% and +15%. Operation outside of this range will require further diagnosis to determine the system level issue affecting fuel control. The system will set Diagnostic Trouble Codes (DTC's) for correction factors in the +/- 30%-35% range.

If total fuel correction is found to be operating outside of the normal range additional diagnostic procedure will be required to determine the cause. Follow the appropriate Symptom Routine or DTC Chart for additional help.

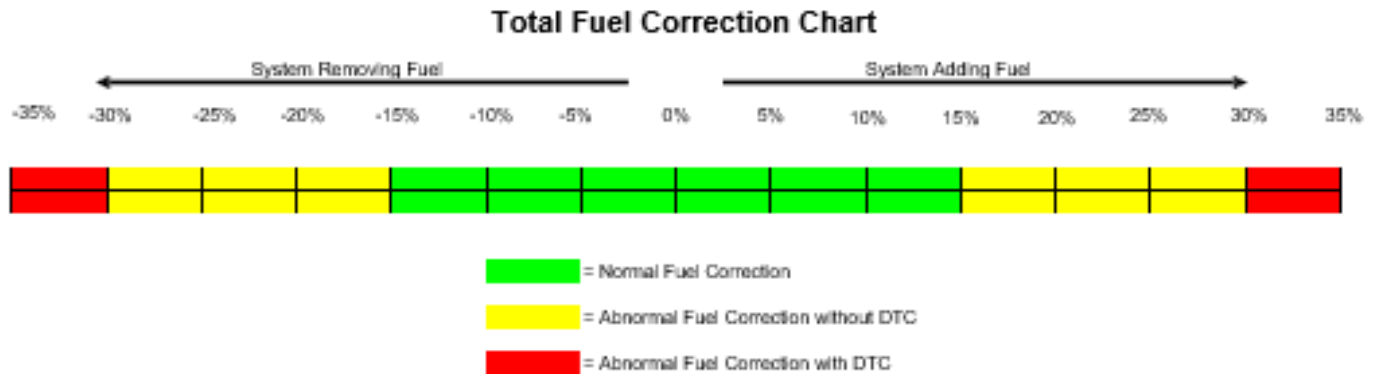

## FUEL SYSTEM SYMPTOM DIAGNOSTICS

Checks	Action
<p>Before Using This Section</p>	<p>Before using this section, you should have performed On Board Diagnostic(OBD) Check and determined that:</p> <ol style="list-style-type: none"> <li>1. The ECM and MIL are operating correctly.</li> <li>2. There are no Diagnostic Trouble Codes (DTCs) stored, or a DTC exists but without a MIL.</li> </ol> <p>Several of the following symptom procedures call for a careful visual and physical check. These checks are very important as they can lead to prompt diagnosis and correction of a problem.</p>
<p>Fuel System Check</p>	<ol style="list-style-type: none"> <li>1. Verify the customer complaint.</li> <li>2. Locate the correct symptom table.</li> <li>3. Check the items indicated under that symptom.</li> <li>4. Operate the equipment under the conditions the symptom occurs. Verify HEGO switching between lean and rich. <b>IMPORTANT! Normal HEGO switching indicates the fuel system is in closed loop and operating correctly at that time.</b></li> <li>5. Take a data snapshot using the DST under the condition that the symptom occurs to review at a later time.</li> </ol>
<p>Visual and Physical Checks</p>	<ul style="list-style-type: none"> <li>• Check all ECM system fuses and circuit breakers.</li> <li>• Check the ECM ground for being clean, tight and in its proper location.</li> <li>• Check the vacuum hoses for splits, kinks and proper connections.</li> <li>• Check thoroughly for any type of leak or restriction.</li> <li>• Check for air leaks at all the mounting areas of the intake manifold sealing surfaces.</li> <li>• Check for proper installation of the mixer assembly.</li> <li>• Check for air leaks at the mixer assembly.</li> </ul> <p>Check the ignition wires for the following conditions:</p> <ul style="list-style-type: none"> <li>• Cracking</li> <li>• Hardening</li> <li>• Proper routing</li> <li>• Carbon tracking.</li> </ul> <ul style="list-style-type: none"> <li>• Check the wiring for the following items: proper connections, pinches or cuts.</li> <li>• The following symptom tables contain groups of possible causes for each symptom. The order of these procedures is not important. If the DST readings do not indicate a problem, then proceed in a logical order, easiest to check or most likely to cause the problem.</li> </ul>

## INTERMITTENT

Checks	Action
<p><b>DEFINITION:</b> The problem may or may not turn ON the (MIL) or store a Diagnostic Trouble Code (DTC).</p>	
Preliminary Checks	<p>Do not use the DTC tables. If a fault is an intermittent, the use of the DTC tables with this condition may result in the replacement of good parts.</p>
Faulty Electrical Connections or Wiring	<p>Faulty electrical connections or wiring can cause most intermittent problems. Check the suspected circuit for the following conditions:</p> <ul style="list-style-type: none"> <li>• Faulty fuse or circuit breaker, connectors poorly mated, terminals not fully seated in the connector (backed out). Terminals not properly formed or damaged.</li> <li>• Wire terminals poorly connected.</li> <li>• Terminal tension is insufficient.</li> <li>• Carefully remove all the connector terminals in the problem circuit in order to ensure the proper contact tension.</li> <li>• If necessary, replace all the connector terminals in the problem circuit in order to ensure the proper contact tension (except those noted as “Not Serviceable”). See section <i>Wiring Schematics</i>.</li> <li>• Checking for poor terminal to wire connections requires removing the terminal from the connector body.</li> </ul>
Operational Test	<p>If a visual and physical check does not locate the cause of the problem, operate the vehicle with the DST connected. When the problem occurs, an abnormal voltage or scan reading indicates a problem circuit.</p>
Intermittent MIL Illumination	<p>The following components can cause intermittent MIL and no DTC(s):</p> <ul style="list-style-type: none"> <li>• A defective relay.</li> <li>• Switch that can cause electrical system interference. Normally, the problem will occur when the faulty component is operating.</li> <li>• The improper installation of add on electrical devices, such as lights, 2-way radios, electric motors, etc.</li> <li>• The ignition secondary voltage shorted to a ground.</li> <li>• The MIL circuit or the Diagnostic Test Terminal intermittently shorted to ground.</li> <li>• The MIL wire grounds.</li> </ul>
Loss of DTC Memory	<p>To check for the loss of the DTC Memory:</p> <ol style="list-style-type: none"> <li>1. Disconnect the TMAP sensor.</li> <li>2. Idle the engine until the MIL illuminates.</li> <li>3. The ECM should store a TMAP DTC which should remain in the memory when the ignition is turned OFF. If the TMAP DTC does not store and re-main, the ECM is faulty.</li> </ol>

## NO START

Checks	Action
<b>DEFINITION:</b> The engine cranks OK but does not start.	
Preliminary Checks	None
ECM Checks	<p>Use the DST to:</p> <ul style="list-style-type: none"> <li>• Check for proper communication with both the ECM.</li> <li>• Check all system fuses engine fuse holder. Refer to <i>Engine Controls Schematics</i>.</li> <li>• Check battery power, ignition power and ground circuits to the ECM. Re-fer to <i>Engine Control Schematics</i>. Verify voltage and/or continuity for each.</li> </ul>
Sensor Checks	<ul style="list-style-type: none"> <li>• Check the TMAP sensor.</li> <li>• Check the cam angle sensor for output (RPM).</li> </ul>
Fuel System Checks	<p><b>Important:</b> A closed LPG manual fuel shut off valve will create a no startcondition.</p> <ul style="list-style-type: none"> <li>• Check for air intake system leakage between the mixer and the throttlebody. Verify proper operation of the low-pressure lock-off solenoids.</li> <li>• Verify proper operation of the fuel control solenoids.</li> <li>• Check the fuel system pressures.</li> <li>• Refer to the <i>LPG Fuel System Diagnosis</i>.</li> <li>• Check for proper mixer air valve operation.</li> </ul>
Ignition System Checks	<p>Note: LPG being a gaseous fuel requires higher secondary ignition systemvoltages for the equivalent gasoline operating conditions.</p> <ol style="list-style-type: none"> <li>1. Check for the proper ignition voltage output with <i>J 26792</i> or the equivalent.</li> <li>2. Verify that the spark plugs are correct for use with LPG.</li> </ol> <p>Check the spark plugs for the following conditions:</p> <ul style="list-style-type: none"> <li>• Wet plugs.</li> <li>• Cracks or any damages.</li> <li>• Wear.</li> <li>• Improper gap.</li> <li>• Burned electrodes.</li> <li>• Heavy deposits.</li> <li>• Check for bare or shorted ignition wires.</li> <li>• Check for loose ignition coil connections at the coil or wiring harness with intermittent connection.</li> </ul>

## NO START

Checks	Action
Engine Mechanical Checks	<p><b>Important:</b> The LPG Fuel system is more sensitive to intake manifold leak-age than the gasoline fuel system.</p> <p>Check for the following:</p> <ul style="list-style-type: none"> <li>• Vacuum leaks.</li> <li>• Improper valve timing.</li> <li>• Low compression.</li> <li>• Improper valve clearance.</li> <li>• Worn rocker arms.</li> <li>• Broken or weak valve springs.</li> </ul> <p>Worn camshaft lobes.</p>
Exhaust System Checks	<p>Check the exhaust system for a possible restriction:</p> <ul style="list-style-type: none"> <li>• Inspect the exhaust system for damaged or collapsed pipes:</li> <li>• Inspect the muffler for signs of heat distress or for possible internal failure.</li> <li>• Check for possible plugged catalytic converter. Refer to <i>Restricted Exhaust System Diagnosis</i>.</li> </ul>



## HARD START

Checks	Action
<p><b>DEFINITION:</b> The engine cranks OK but does not start for a long time. The engine does eventually run or may start but immediately dies.</p>	
Preliminary Checks	Make sure the vehicle's operator is using the correct starting procedure.
Sensor Checks	<ul style="list-style-type: none"> <li>• Check the Engine Coolant Temperature sensor with the DST. Compare the engine coolant temperature with the ambient air temperature on a cold engine. If the coolant temperature reading is more than 10 degrees greater or less than the ambient air temperature on a cold engine, check for high resistance in the coolant sensor circuit. Check the cam angle sensor.</li> <li>• Check the Throttle Position (TPS) and Foot Pedal Position (FPP) sensor connections.</li> </ul>
Fuel System Checks	<p><b>Important:</b> A closed LPG manual fuel shut off valve will create an extended crank OR no start condition.</p> <ul style="list-style-type: none"> <li>• Verify the excess flow valve is not tripped or that the manual shut-off valve is not closed.</li> </ul> <p>Check mixer assembly for proper installation and leakage.</p> <ul style="list-style-type: none"> <li>• Verify proper operation of the low-pressure lock-off solenoid.</li> <li>• Verify proper operation of the EPR.</li> <li>• Check for air intake system leakage between the mixer and the throttle body. Check the fuel system pressures. Refer to the <i>Fuel System Diagnosis</i>.</li> </ul>
Ignition System Checks	<p>Note: LPG being a gaseous fuel requires higher secondary ignition system voltages for the equivalent gasoline operating conditions.</p> <ul style="list-style-type: none"> <li>• Check for the proper ignition voltage output with J 26792 or the equivalent.</li> <li>• Verify that the spark plugs are the correct type and properly gapped.</li> </ul> <p>Check the spark plugs for the following conditions:</p> <ul style="list-style-type: none"> <li>• Wet plugs.</li> <li>• Cracks.</li> <li>• Wear.</li> <li>• Burned electrodes.</li> <li>• Heavy deposits</li> <li>• Check for bare or shorted ignition wires.</li> <li>• Check for moisture in the distributor cap.</li> <li>• Check for loose ignition coil connections.</li> </ul> <p><b>Important:</b></p> <ol style="list-style-type: none"> <li>1. If the engine starts but then immediately stalls, check the cam angle sensor.</li> <li>2. Check for improper gap, debris, or faulty connections.</li> </ol>

## HARD START

Checks	Action
Engine Mechanical Checks	<p><b>Important:</b> The LPG Fuel system is more sensitive to intake manifold leak-age than the gasoline fuel supply system.</p> <p>Check for the following:</p> <ul style="list-style-type: none"> <li>• Vacuum leaks</li> <li>• Improper valve timing</li> <li>• Low compression</li> <li>• Improper valve clearance.</li> <li>• Worn rocker arms.</li> <li>• Broken or weak valve springs</li> <li>• Worn camshaft lobes.</li> </ul> <p>Check the intake and exhaust manifolds for casting flash.</p>
Exhaust System Checks	<p>Check the exhaust system for a possible restriction:</p> <ul style="list-style-type: none"> <li>• Inspect the exhaust system for damaged or collapsed pipes.</li> <li>• Inspect the muffler for signs of heat distress or for possible internal failure.</li> </ul> <p>Check for possible plugged catalytic converter. Refer to <i>Restricted ExhaustSystem Diagnosis</i>.</p>

## CUTS OUT, MISSES

Checks	Action
<p><b>DEFINITION:</b> A surging or jerking that follows engine speed, usually more pronounced as the engine load increases, but normally felt below 1500 RPM. The exhaust has a steady spitting sound at idle, low speed, or hard acceleration for the fuel starvation that can cause the engine to cut-out.</p>	
Preliminary Checks	None
Ignition System Checks	<ol style="list-style-type: none"> <li>1. Start the engine.</li> <li>2. Check for proper ignition coil resistance: <ul style="list-style-type: none"> <li>• Primary Value: 0.4 – 2 Ohms</li> <li>• Secondary Value: 6K – 15K Ohms</li> </ul> </li> <li>3. Check for a cylinder misfire, damaged catalyst and for poor running conditions.</li> <li>4. Verify that the spark plugs are the correct type and properly gapped.</li> </ol> <p>Remove the spark plugs and check for the following conditions:</p> <ul style="list-style-type: none"> <li>• Insulation cracks.</li> <li>• Wear.</li> <li>• Improper gap.</li> <li>• Burned electrodes.</li> <li>• Heavy deposits.</li> <li>• Orange fouled spark plugs and/or damaged spark plugs.</li> </ul> <p>Visually/Physically inspect the secondary ignition for the following:</p> <ul style="list-style-type: none"> <li>• Ignition wires for arcing and proper routing.</li> <li>• Cross-firing.</li> <li>• Ignition coils for cracks or carbon tracking.</li> <li>• Wiring harness intermittent connection.</li> </ul>
Engine Mechanical Checks	<p>Perform a cylinder compression check. Check the engine for the following:</p> <ul style="list-style-type: none"> <li>• Improper valve timing.</li> <li>• Improper valve clearance.</li> <li>• Worn rocker arms.</li> <li>• Worn camshaft lobes.</li> <li>• Broken or weak valve springs.</li> <li>• Check the intake and exhaust manifold passages for casting flash.</li> </ul>
Fuel System Checks	<p>Check the fuel system:</p> <ul style="list-style-type: none"> <li>• Plugged fuel filter.</li> <li>• Low fuel pressure, etc. Refer to <i>LPG Fuel System Diagnosis</i>.</li> <li>• Check the condition of the wiring to the low-pressure lock-off solenoid.</li> </ul>
Additional Check	<p>Check for Electromagnetic Interference (EMI), which may cause a misfire condition. Using the DST, monitor the engine RPM and note sudden increases in rpms displayed on the scan tool but with little change in the actual engine rpm. If this condition exists, EMI may be present. Check the routing of the secondary wires and the ground circuit.</p>

## HESITATION, SAG, STUMBLE

Checks	Action
<p><b>DEFINITION:</b> The engine has a momentary lack of response when putting it under load. The condition can occur at any engine speed. The condition may cause the engine to stall if it's severe enough.</p>	
Preliminary Checks	None.
Fuel System Checks	<ul style="list-style-type: none"> <li>• Check the fuel pressure. Refer to <i>LPG Fuel System Diagnosis</i>.</li> <li>• Check for low fuel pressure during a moderate or full throttle acceleration. If the fuel pressure drops below specification, there is possibly a faulty low-pressure regulator or a restriction in the fuel system.</li> <li>• Check the TMAP sensor response and accuracy.</li> <li>• Check Shut-Off electrical connection.</li> <li>• Check the mixer air valve for sticking or binding.</li> <li>• Check the mixer assembly for proper installation and leakage. Check the EPR.</li> </ul>
Ignition System Checks	<p>Note: LPG being a gaseous fuel requires higher secondary ignition system voltages for the equivalent gasoline operating conditions. If a problem is reported on LPG and not gasoline, do not discount the possibility of an LPG only ignition system failure and test the system accordingly.</p> <ul style="list-style-type: none"> <li>• Check for the proper ignition voltage output with <i>J 26792</i> or the equivalent. Verify that the spark plugs are the correct type and properly gapped.</li> <li>• Check for faulty spark plug wires.</li> <li>• Check for fouled spark plugs.</li> </ul>
Additional Check	<ul style="list-style-type: none"> <li>• Check for manifold vacuum or air induction system leaks.</li> <li>• Check the alternator output voltage.</li> </ul>

## BACKFIRE

Checks	Action
<p><b>DEFINITION:</b> <i>The fuel ignites in the intake manifold, or in the exhaust system, making a loud popping noise.</i></p>	
Preliminary Check	None.
Ignition System Checks	<p><b>Important! LPG, being a gaseous fuel, requires higher secondary ignition system voltages for the equivalent gasoline operating conditions. The ignition system must be maintained in peak condition to prevent backfire.</b></p> <ul style="list-style-type: none"> <li>• Check for the proper ignition coil output voltage using the spark tester. J26792 or the equivalent.</li> <li>• Check the spark plug wires by connecting an ohmmeter to the ends of each wire in question. If the meter reads over 30,000 ohms, replace the wires.</li> <li>• Check the connection at ignition coil.</li> <li>• Check for deteriorated spark plug wire insulation.</li> </ul> <p>Remove the plugs and inspect them for the following conditions:</p> <ul style="list-style-type: none"> <li>• Wet plugs.</li> <li>• Cracks.</li> <li>• Wear.</li> <li>• Improper gap.</li> <li>• Burned electrodes.</li> <li>• Heavy deposits.</li> </ul>
Engine Mechanical Check	<p><b>Important! The LPG Fuel system is more sensitive to intake manifold leakage than a gasoline fuel supply system.</b></p> <p>Check the engine for the following:</p> <ul style="list-style-type: none"> <li>• Improper valve timing.</li> <li>• Engine compression.</li> <li>• Manifold vacuum leaks.</li> <li>• Intake manifold gaskets.</li> <li>• Sticking or leaking valves.</li> <li>• Exhaust system leakage.</li> <li>• Check the intake and exhaust system for casting flash or other restrictions.</li> </ul>
Fuel System Checks	Perform a fuel system diagnosis. Refer to <i>LPG Fuel System Diagnosis</i> .

## LACK OF POWER, SLUGGISHNESS

Checks	Action
<b>DEFINITION:</b> <i>The engine delivers less than expected power.</i>	
Preliminary Checks	<ul style="list-style-type: none"> <li>• Refer to the <i>LPG Fuel system OBD System Check</i>.</li> <li>• Compare the customer's vehicle with a similar unit to verify customer has an actual problem. <i>Do not compare the power output of the vehicle operating on LPG to a vehicle operating on gasoline as the fuels do have different drive feel characteristics.</i></li> <li>• Remove the air filter and check for dirt or restriction.</li> <li>• Check the vehicle transmission.</li> <li>• Refer to the OEM transmission diagnostics.</li> </ul>
Fuel System Checks	<ul style="list-style-type: none"> <li>• Check for a restricted fuel filter, contaminated fuel, or improper fuel pressure. Refer to <i>LPG Fuel System Diagnosis</i>.</li> <li>• Check for the proper ignition output voltage with the spark tester <i>J 26792</i> or the equivalent.</li> <li>• Check for proper installation of the mixer assembly. Check all air inlet ducts for condition and proper installation.</li> <li>• Check for fuel leaks between the EPR and the mixer.</li> <li>• Verify that the LPG tank manual shut-off valve is fully open.</li> <li>• Verify that liquid fuel (not vapor) is being delivered to the EPR.</li> </ul>
Sensor Checks	<ul style="list-style-type: none"> <li>• Check the Heated Exhaust Gas Oxygen Sensors (HEGO) for contamination and performance. Check for proper operation of the TMAP sensor.</li> <li>• Check for proper operation of the TPS and FPP sensors.</li> </ul>
Exhaust System Checks	<p>Check the exhaust system for a possible restriction:</p> <ul style="list-style-type: none"> <li>• Inspect the exhaust system for damaged or collapsed pipes.</li> <li>• Inspect the muffler for signs of heat distress or for possible internal failure.</li> <li>• Check for possible plugged catalytic converter.</li> </ul>
Engine Mechanical Check	<p>Check the engine for the following:</p> <ul style="list-style-type: none"> <li>• Engine compression.</li> <li>• Valve timing.</li> <li>• Improper or worn camshaft.</li> <li>• Refer to <i>Engine Mechanical</i> in the Service Manual.</li> </ul>
Additional Check	<ul style="list-style-type: none"> <li>• Check the ECM grounds for being clean, tight, and in their proper locations.</li> <li>• Check the alternator output voltage.</li> </ul> <p>If all procedures have been completed and no malfunction has been found, review and inspect the following items:</p> <ul style="list-style-type: none"> <li>• Visually and physically, inspect all electrical connections within the suspected circuit and/or systems.</li> <li>• Check the DST data.</li> </ul>

## ROUGH, UNSTABLE, OR INCORRECT IDLE

Checks	Action
<b>DEFINITION:</b> The engine runs unevenly at idle. If severe enough, the engine may shake.	
Preliminary Check	None.
Sensor Checks	<p>Check the Heated Exhaust Gas Oxygen Sensors (HEGO) performance:</p> <ul style="list-style-type: none"> <li>• Check for silicone contamination from fuel or improperly used sealant. If contaminated, the sensor may have a white powdery coating result in a high but false signal voltage (rich exhaust indication). The ECM will reduce the amount of fuel delivered to the engine causing a severe drivability problem.</li> </ul> <p>Check the Temperature Manifold Absolute Pressure (TMAP) sensor response and accuracy.</p>
Fuel System Checks	<ul style="list-style-type: none"> <li>• Check for rich or lean symptom that causes the condition.</li> <li>• Drive the vehicle at the speed of the complaint.</li> <li>• Monitoring the oxygen sensors will help identify the problem.</li> <li>• Check for a sticking mixer air valve.</li> <li>• Verify proper operation of the EPR.</li> <li>• Perform a cylinder compression test. Refer to <i>Engine Mechanical</i> in the Service Manual.</li> <li>• Check the EPR fuel pressure. Refer to the <i>LPG Fuel System Diagnosis</i>.</li> <li>• Check mixer assembly for proper installation and connection.</li> </ul>
Ignition System Checks	<ul style="list-style-type: none"> <li>• Check for the proper ignition output voltage using the spark tester J26792 or the equivalent.</li> <li>• Verify that the spark plugs are the correct type and properly gapped.</li> </ul> <p>Remove the plugs and inspect them for the following conditions:</p> <ul style="list-style-type: none"> <li>• Wet plugs.</li> <li>• Cracks.</li> <li>• Wear.</li> <li>• Improper gap.</li> <li>• Burned electrodes.</li> <li>• Blistered insulators.</li> <li>• Heavy deposits.</li> </ul> <p>Check the spark plug wires by connecting an ohmmeter to the ends of each wire in question. If the meter reads over 30,000 ohms, replace the wires.</p>
Additional Checks	<p><b>Important:</b> The LPG Fuel system is more sensitive to intake manifold leak-age than the gasoline fuel supply system.</p> <ul style="list-style-type: none"> <li>• Check for vacuum leaks. Vacuum leaks can cause a higher than normal idle and low throttle angle control command.</li> <li>• Check the ECM grounds for being clean, tight, and in their proper locations. Check the battery cables and ground straps. They should be clean and secure. Erratic voltage may cause all sensor readings to be skewed resulting in poor idle quality.</li> </ul>

ROUGH, UNSTABLE, OR INCORRECT IDLE,  
STALLING

Checks	Action
Engine Mechanical Check	Check the engine for: <ul style="list-style-type: none"><li>• Broken motor mounts.</li><li>• Improper valve timing.</li><li>• Low compression.</li><li>• Improper valve clearance.</li><li>• Worn rocker arms.</li><li>• Broken or weak valve springs.</li><li>• Worn camshaft lobes.</li></ul>



# Electrical Section

## How to obtain electrical schematics

Use the cloud based PSI Support Portal to obtain the correct wiring diagram when needed for diagnostic's. If you do not have access to the PSI Support Portal contact the equipment OEM or PSI technical support and request the wiring schematic for the engine you are diagnosing.

PSI's wire harnesses will contain one or more customer interface connector's ("CIC"). The CIC is where the PSI harness stops and the OEM wiring begins.

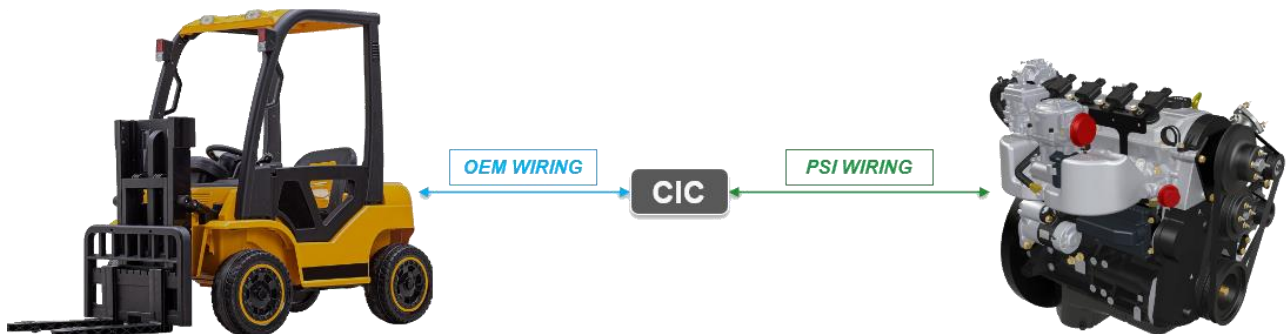
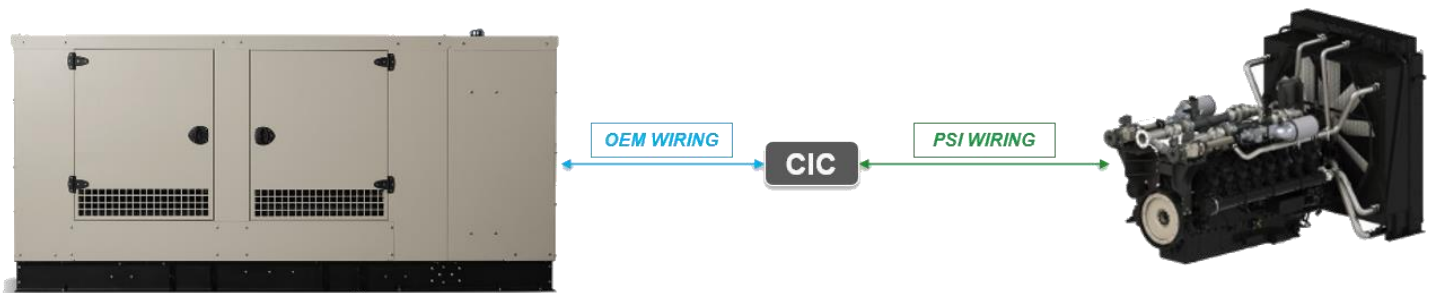

# 4G Display

4G Diagnostic Software can be downloaded from [www.psiengines.com/software](http://www.psiengines.com/software)

**PSI** POWER SOLUTIONS INTERNATIONAL

Company ▾ Solutions ▾ Products ▾ Parts and service ▾ Investors Contact

## PSI Software Download Resource Center

### 4G Display

Diagnostic Software used on PSI Industrial and Power Systems Engines using 4G ECM Hardware

### GCP Display

Diagnostic Software used on PSI Industrial Engines using GCP ECM Hardware

### Software Passwords

Passwords are required for both GCP and 4G Display Diagnostic Software

### ECOM Driver

This software driver is included in the download package's above. If you want to **download the driver only**, click the download link.

### PSI Field Programmer

The PSI Field Programmer can be used to update calibrations on certain PSI engines

# Engine Wire Harness Repair

## ON-VEHICLE SERVICE WIRE HARNESS REPAIR

The ECM harness electrically connects the ECM to various components in both the engine and passenger compartments.

Wire harnesses should be replaced with proper part number harnesses. When wires are spliced into a harness, use wire with high temperature insulation only.

Low current and voltage levels are used in the system, so it is important that the best possible bond at all wire splices be made by soldering the splices.

### CONNECTORS AND TERMINALS

Use care when probing a connector or replacing terminals in them to prevent shorting opposite terminals and damage certain components. Always use jumper wires between connectors, for circuit checking. Do not probe through the Weather-Pack seals with oversized wire probes. Use tachometer adapter J 35812 (or equivalent) which provides an easy hook up of the tach lead. The connector test adapter kit J 35616 (or equivalent), contains an assortment of flexible connectors used to probe terminals during diagnosis. Fuse remover and test tool BT 8616, or equivalent, is used for removing a fuse and to adapt fuse holder, with a meter, for diagnosis.

Do not solder oxygen sensor wire terminals as these wire ends are used for the sensor's oxygen reference.

Open circuits are often difficult to locate by sight due to dirt, oxidation, or terminal misalignment. Merely wiggling a connector on a sensor, or in the wiring harness, may correct the open circuit condition. This should always be considered, when an open circuit, or failed sensor is indicated. Intermittent problems may also be caused by oxidized or loose connections.

Before making a connector repair, be certain of the type of connector. Weather-Pack and Com-pact Three connectors look similar but are serviced differently.

### REPAIRING TWISTED/SHIELDED CABLE

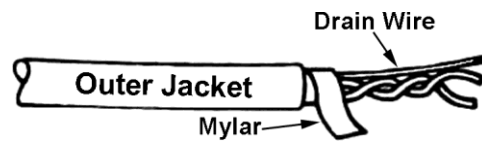

1. Remove outer jacket

2. Unwrap aluminum/Mylar tape. Do not remove Mylar.



3. Untwist conductors, strip insulation as necessary.

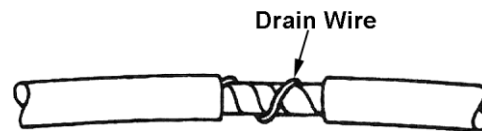

4. Splice wire using splice clips and rosin core solder. Wrap each splice to insulate.

5. Wrap with Mylar and drain wire (uninsulated) wire.

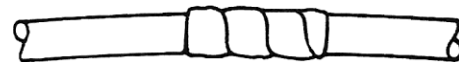

6. Tape over entire juncture and secure.

### REPAIRING TWISTED LEADS



1. Locate Damaged Wire.
2. Remove insulation as required.

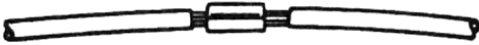

3. Splice two wires together using splice clips and rosin core solder.

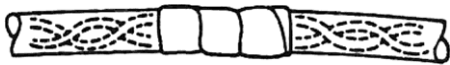

4. Cover splice with tape to insulate from other wires.
5. Retwist as before and tape with electrical tape and hold in place.

### MICRO-PACK

Refer to Figure 2 and repair procedure for replacement of a Micro-Pack terminal.

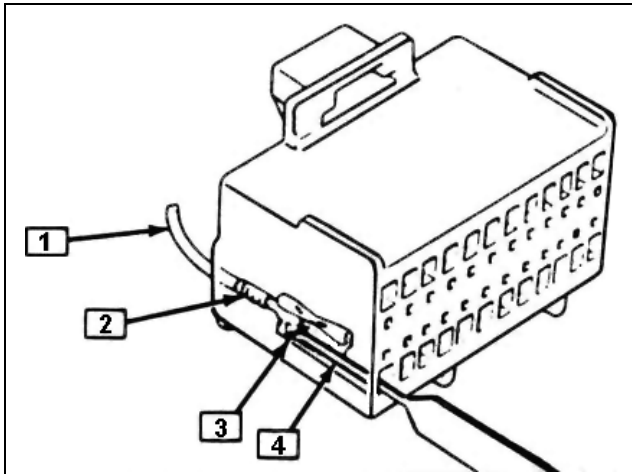

**Micropack Connector**

1. Cable
2. Terminal
3. Locking Tang
4. Tool J33095/BT8234-A

### METRI-PACK

Some connectors use terminals called Metri-Pack Series 150. They are also called "Pull-To-Seat" terminals because of the method of installation. The wire is inserted through the seal and connector, the terminal is crimped on the wire and then pulled back into the connector to seat it in place.

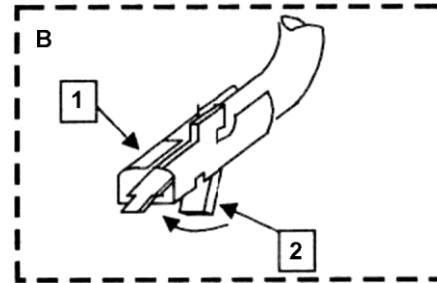
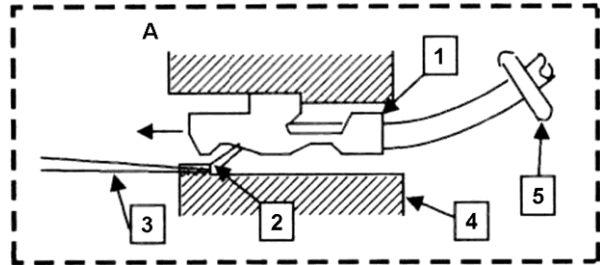

### Metri-Pack Series 150 Terminal Removal

1. Slide the seal back on the wire.
2. Insert tool BT-8518, or J 35689, or equivalent, as shown in insert "A" and "B" to release the terminal locking tab (2).
3. Push the wire and terminal out through the connector. If reusing the terminal, reshape the locking tab (2).

### WEATHER-PACK

A Weather-Pack connector can be identified by a rubber seal, at the rear of the connector. The connector is used in the engine compartment to protect against moisture and dirt that may oxidize and/or corrode the terminals. Given the low voltage and current levels found in the electronics system, this protection is necessary to ensure a good connection.

## WEATHER-PACK TERMINAL REPAIR

locking feature for the connector. They are used to improve the connector reliability by retaining the terminals, if the small terminal lock tabs are not positioned properly.

Weather-Pack connections cannot be replaced with standard connections. Additional instructions are provided with Weather-Pack connector and terminal packages.

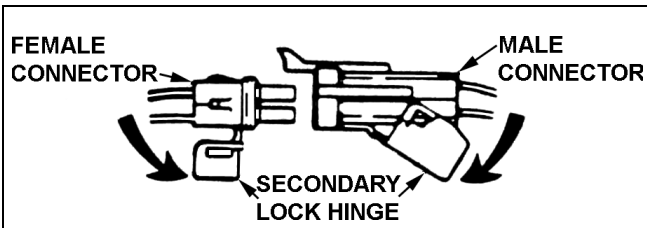

1. Open secondary lock hinge on connector.

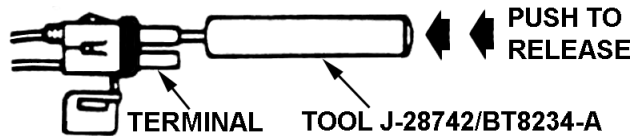

2. Remove terminal using tool.

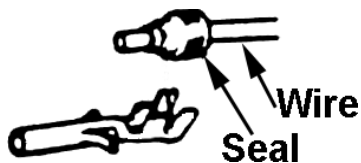

3. Cut wire immediately behind cable seal

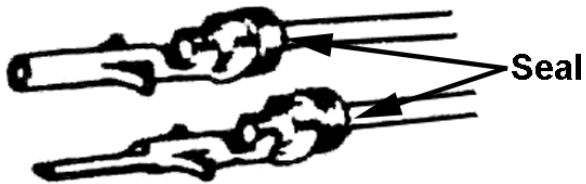

4. Replace terminal.
- Slip new seal onto wire
  - Strip 5 mm (.2") of insulation from wire.
  - Crimp terminal over wire and seal.

5. Push terminal and connector and engage locking tangs.

6. Close secondary lock hinge.

Use tool J M28742, or BT8234-A or equivalent to remove the pin and sleeve terminals. If the removal is attempted with an ordinary pick, there is a good chance that the terminal will be bent or deformed. Unlike standard blade type terminals, these terminals cannot be straightened once they are bent.

Verify that the connectors are properly seated and all the sealing rings in place, when connecting leads. The hinge type flap provides a backup, or secondary





# **4G Diagnostic Trouble Codes (DTCs)**

# **Malfunction Indicator Lamp (MIL) Operation**

## **How does my MIL work?**

The emissions control system utilizes a MIL to warn the operator or technician of a possible issue with the engine or emissions control system. The system will keep the MIL illuminated for the entire key cycle in which the trouble code was set. It will keep the MIL illuminated for three additional engine run cycles under the following two circumstances: (1) The fault caused the engine to shut down or (2) the fault is related to the exhaust gas oxygen (EGO) sensors. This function is called MIL persistence.

## **How does MIL persistence work?**

In the event the DTC **is** related to either an engine shutdown fault OR an oxygen sensor faults the following statement applies: If the vehicle is not serviced by a technician and the condition causing the MIL illumination (DTC) no longer exists, the MIL will remain illuminated for the 3 additional start cycles. The MIL will go out on the 4th start cycle if the condition does not reoccur.

In the event the DTC **is not** related to an engine shut down or an oxygen sensor fault and the condition causing the MIL illumination (DTC) no longer exists, the MIL will go out at the next run cycle.

If the condition is serviced by a technician and the DTC is cleared using a Diagnostic Service Tool (DST), the MIL will go out immediately.

Diagnostic Trouble Codes (DTC) are permanently retained in the historic DTC section until cleared with a DST or the auto clear requirements are met. The auto clear feature will clear out historic faults after 40 run cycles.

## **What are the requirements for a run cycle?**

A run cycle is when the engine speed is above the “run speed” set point for 1.5 seconds or longer. The “run speed” is the transition point when the ECM recognizes the engine is going from the cranking parameters to the engine running parameters. The run speed is typically set at 450 rpm

## DIAGNOSTIC TROUBLE CODE (DTC) CHART – **SORTED BY DTC**

DTC & Description	SPN	FMI
DTC 6 Lockoff open / ground short	632	4
DTC 7 Lockoff short to power	632	3
DTC 11 Intake cam / distributor position	520800	7
DTC 16 Never crank synced at start	636	8
DTC 24 Exhaust cam position	520801	7
DTC 31 EGOH1 open / ground short	3222	4
DTC 32 EGOH1 short to power	3222	3
DTC 37 EGOH3 open / ground short	3261	4
DTC 38 EGOH3 short to power	3261	3
DTC 51 EGOH2 open / ground short	3232	4
DTC 52 EGOH2 short to power	3232	3
DTC 57 EGOH4 open / ground short	3271	4
DTC 58 EGOH4 short to power	3271	3
DTC 87 Primary fuel pressure low	94	1
DTC 87 CFV RLV charge pressure low	3601	17
DTC 88 Primary fuel pressure high	94	0
DTC 91 Primary FP low voltage	94	4
DTC 92 Primary FP high voltage	94	3
DTC 107 MAP low voltage	106	4
DTC 108 MAP high pressure	106	16
DTC 111 IAT higher than expected 1	105	15
DTC 112 IAT low voltage	105	4
DTC 113 IAT high voltage	105	3
DTC 116 ECT higher than expected 1	110	15
DTC 117 ECT / CHT low voltage	110	4
DTC 118 ECT / CHT high voltage	110	3
DTC 121 TPS1 lower than TPS2	51	1
DTC 122 TPS1 low voltage	51	4
DTC 123 TPS1 high voltage	51	3
DTC 127 IAT higher than expected 2	105	0
DTC 128 Failed to reach operating temperature	110	17
DTC 129 BP low pressure	108	1
DTC 134 EGO open / lazy pre-cat 1	3217	5
DTC 140 EGO open / lazy post-cat 1	3256	5
DTC 148 Fuel Run-out Longer Than Expected	632	31
DTC 154 EGO open / lazy pre-cat 2/post-cat 1	3227	5
DTC 160 EGO open / lazy post-cat 2	3266	5
DTC 171 AL high gasoline bank1	4237	0

DTC & Description	SPN	FMI
DTC 172 AL low gasoline bank1	4237	1
DTC 174 AL high gasoline bank2	4239	0
DTC 175 AL low gasoline bank2	4239	1
DTC 182 FT gasoline low	174	4
DTC 183 FT gasoline high	174	3
DTC 187 FT gaseous fuel low	3468	4
DTC 187 FT gaseous fuel extremely low	3468	1
DTC 188 FT gaseous fuel high	3468	3
DTC 217 ECT higher than expected 2	110	0
DTC 219 Max govern speed over-ride	515	15
DTC 221 TPS1 higher than TPS2	51	0
DTC 222 TPS2 low voltage	3673	4
DTC 223 TPS2 high voltage	3673	3
DTC 234 Control overboost	102	0
DTC 236 TIP/TOP active	102	2
DTC 237 TIP/TOP low voltage	102	4
DTC 238 TIP/TOP high voltage	102	3
DTC 261 1 Injector Loop Open or Low-Side Short to Ground	651	5
DTC 262 1 Injector Coil Shorted	651	6
DTC 264 2 Injector Loop Open or Low-Side Short to Ground	652	5
DTC 265 2 Injector Coil Shorted	652	6
DTC 267 3 Injector Loop Open or Low-Side Short to Ground	653	5
DTC 268 3 Injector Coil Shorted	653	6
DTC 270 4 Injector Loop Open or Low-Side Short to Ground	654	5
DTC 271 4 Injector Coil Shorted	654	6
DTC 273 5 Injector Loop Open or Low-Side Short to Ground	655	5
DTC 274 5 Injector Coil Shorted	655	6
DTC 276 6 Injector Loop Open or Low-Side Short to Ground	656	5
DTC 277 6 Injector Coil Shorted	656	6
DTC 279 7 Injector Loop Open or Low-Side Short to Ground	657	5
DTC 280 7 Injector Coil Shorted	657	6
DTC 282 8 Injector Loop Open or Low-Side Short to Ground	658	5
DTC 283 8 Injector Coil Shorted	658	6
DTC 285 9 Injector Loop Open or Low-Side Short to Ground	659	5

DTC 286 9 Injector Coil Shorted	659	6
DTC 288 10 Injector Loop Open or Low-Side Short to Ground	660	5
DTC 289 10 Injector Coil Shorted	660	6
DTC 299 Control underboost	102	1
DTC 301 1 Emissions/catalyst damaging misfire	1323	31
DTC 302 2 Emissions/catalyst damaging misfire	1324	31
DTC 303 3 Emissions/catalyst damaging misfire	1325	31
DTC 304 4 Emissions/catalyst damaging misfire	1326	31
DTC 305 5 Emissions/catalyst damaging misfire	1327	31
DTC 306 6 Emissions/catalyst damaging misfire	1328	31
DTC 307 7 Emissions/catalyst damaging misfire	1329	31
DTC 308 8 Emissions/catalyst damaging misfire	1330	31
DTC 309 9 Emissions/catalyst damaging misfire	1331	31
DTC 310 10 Emissions/catalyst damaging misfire	1332	31
DTC 326 Knock 1 excessive signal	731	2
DTC 327 Knock 1 sensor open	731	4
DTC 331 Knock 2 excessive signal	520197	2
DTC 332 Knock 2 sensor open	520197	4
DTC 336 Crank sync noise	636	2
DTC 337 Crank loss	636	4
DTC 341 Cam sync noise	723	2
DTC 342 Cam loss	723	4
DTC 350 External Spark Module Failure	1268	31
DTC 351 1 External Spark Module Coil Failure	1268	31
DTC 352 2 External Spark Module Coil Failure	1269	31
DTC 353 3 External Spark Module Coil Failure	1270	31
DTC 354 EPR Regulation Pressure Lower than expected	520260	1
DTC 355 5 External Spark Module Coil Failure	1272	31
DTC 356 6 External Spark Module Coil Failure	1273	31
DTC 357 7 External Spark Module Coil Failure	1274	31
DTC 358 8 External Spark Module Coil Failure	1275	31
DTC 359 Fuel run-out longer than expected	632	31
DTC 359 9 External Spark Module Coil Failure	1276	31
DTC 360 10 External Spark Module Coil Failure	1277	31

DTC 420 Gasoline cat monitor bank 1	3050	11
DTC 430 Gasoline cat monitor bank 2	3051	11
DTC 502 Roadspeed loss	84	8
DTC 508 IAC ground short	520201	6
DTC 509 IAC coil open/short	520201	5
DTC 520 Oil pressure low stage 1 (sender)	100	18
DTC 521 Oil pressure high (sender)	100	0
DTC 522 Oil pressure sender low voltage	100	4
DTC 523 Oil pressure sender high voltage	100	3
DTC 524 Oil pressure low (switch)	100	1
DTC 524 Oil pressure low stage 2 (sender)	100	1
DTC 562 Vbat Voltage low	168	17
DTC 563 Vbat Voltage high	168	15
DTC 601 Flash checksum invalid	628	13
DTC 604 RAM failure	630	12
DTC 606 COP failure	629	31
DTC 615 Start relay coil open	1321	5
DTC 616 Start relay control ground short	1321	4
DTC 617 Start relay coil short to power	1321	3
DTC 627 Fpump relay coil open	1348	5
DTC 628 FPump motor loop open or high-side shorted to ground	1347	5
DTC 628 FPump relay control ground short	1348	4
DTC 629 FPump motor high-side shorted to power	1347	6
DTC 629 Fpump relay coil short to power	1348	3
DTC 642 5VE1 low voltage	1079	4
DTC 643 5VE1 high voltage	1079	3
DTC 650 MIL open	1213	5
DTC 652 5VE2 low voltage	1080	4
DTC 653 5VE2 high voltage	1080	3
DTC 670 Glow Plug Control Unit Failure	676	11
DTC 671 1 Glow Plug Short to Ground	2899	4
DTC 672 2 Glow Plug Short to Ground	2899	4
DTC 673 3 Glow Plug Short to Ground	2899	4
DTC 674 4 Glow Plug Short to Ground	2899	4
DTC 675 5 Glow Plug Short to Ground	2899	4
DTC 676 6 Glow Plug Short to Ground	2899	4
DTC 677 7 Glow Plug Short to Ground	2899	4
DTC 678 8 Glow Plug Short to Ground	2899	4
DTC 679 9 Glow Plug Short to Ground	2899	4
DTC 680 10 Glow Plug Short to Ground	2899	4
DTC 685 Power relay coil open	1485	5

DTC 686 Power relay control ground short	1485	4
DTC 687 Power relay coil short to power	1485	3
DTC 698 5VE3 low voltage	3511	4
DTC 699 5VE3 high voltage	3511	3
DTC 726 Max Govern Speed Override	515	15
DTC 916 Shift actuator feedback out-of-range	520226	3
DTC 919 Shift unable to reach desired gear	520226	7
DTC 920 Shift actuator or drive circuit failure	520226	31
DTC 1068 MAP higher than expected	3563	15
DTC 1087 Secondary fuel pressure low	94	1
DTC 1088 Secondary fuel pressure high	94	0
DTC 1111 Fuel rev limit	515	16
DTC 1112 Spark rev limit	515	0
DTC 1113 RPM higher than expected	515	31
DTC 1114 Unable to achieve low target speed	515	15
DTC 1121 FPP1/2 simultaneous voltages out of range (redundancy lost)	91	31
DTC 1122 FPP1/2 do not match each other or the IVS (redundancy lost)	520199	11
DTC 1131 WGP high voltage	1192	3
DTC 1132 WGP low voltage	1192	4
DTC 1151 CL high LPG	4236	0
DTC 1152 CL low LPG	4236	1
DTC 1153 CL high NG	4236	0
DTC 1154 CL low NG	4236	1
DTC 1155 CL high gasoline bank1	4236	0
DTC 1156 CL low gasoline bank1	4236	1
DTC 1157 CL high gasoline bank2	4238	0
DTC 1158 CL low gasoline bank2	4238	1
DTC 1161 AL high LPG	4237	0
DTC 1162 AL low LPG	4237	1
DTC 1163 AL high NG	4237	0
DTC 1164 AL low NG	4237	1
DTC 1165 LPG cat monitor	3050	11
DTC 1166 NG cat monitor	3050	11
DTC 1171 EPR / CFV regulation pressure higher than expected	520260	0
DTC 1172 EPR / CFV regulation pressure lower than expected	520260	1
DTC 1173 EPR / CFV comm lost	520260	31
DTC 1174 EPR / CFV voltage supply high	520260	3

DTC 1175 EPR / CFV voltage supply low	520260	4
DTC 1176 EPR / CFV internal actuator fault detection	520260	12
DTC 1177 EPR / CFV internal circuitry fault detection	520260	12
DTC 1178 EPR / CFV internal comm fault detection	520260	12
DTC 1179 CFV flow higher than commanded	520260	15
DTC 1180 CFV flow lower than commanded	520260	17
DTC 1182 Fuel impurity level high	520401	0
DTC 1183 EPR autozero / lockoff failed	520803	31
DTC 1211 APS1 high voltage	3464	3
DTC 1212 APS1 low voltage	3464	4
DTC 1213 APS2 high voltage	3464	3
DTC 1214 APS2 low voltage	3464	4
DTC 1215 APS1 higher than APS2	3464	0
DTC 1216 APS1 lower than APS2	3464	1
DTC 1217 Unable to reach higher APS	3464	7
DTC 1218 Unable to reach lower APS	3464	7
DTC 1219 APS1/2 simultaneous voltages out of range	3464	31
DTC 1220 BPS1 high voltage	3465	3
DTC 1221 BPS1 low voltage	3465	4
DTC 1222 BPS2 high voltage	3465	3
DTC 1223 BPS2 low voltage	3465	4
DTC 1224 BPS1 higher than BPS2	3465	0
DTC 1225 BPS1 lower than BPS2	3465	1
DTC 1226 Unable to reach higher BPS	3465	7
DTC 1227 Unable to reach lower BPS	3465	7
DTC 1228 BPS1/2 simultaneous voltages out of range	3465	31
DTC 1311 1 Misfire detected	1323	11
DTC 1312 2 Misfire detected	1324	11
DTC 1313 3 Misfire detected	1325	11
DTC 1314 4 Misfire detected	1326	11
DTC 1315 5 Misfire detected	1327	11
DTC 1316 6 Misfire detected	1328	11
DTC 1317 7 Misfire detected	1329	11
DTC 1318 8 Misfire detected	1330	11
DTC 1319 9 Misfire detected	1331	11
DTC 1320 10 Misfire detected	1332	11
DTC 1325 Knock retard at limit	731	15
DTC 1351 1 Spark Plug or Coil Failure	1268	11
DTC 1352 2 Spark Plug or Coil Failure	1269	11

DTC 1353 3 Spark Plug or Coil Failure	1270	11
DTC 1354 4 Spark Plug or Coil Failure	1271	11
DTC 1355 5 Spark Plug or Coil Failure	1272	11
DTC 1356 6 Spark Plug or Coil Failure	1273	11
DTC 1357 7 Spark Plug or Coil Failure	1274	11
DTC 1358 8 Spark Plug or Coil Failure	1275	11
DTC 1359 9 Spark Plug or Coil Failure	1276	11
DTC 1360 10 Spark Plug or Coil Failure	1277	11
DTC 1411 EMWT 1 high voltage	441	3
DTC 1412 EMWT 2 high voltage	442	3
DTC 1413 EMWT 1 low voltage	441	4
DTC 1414 EMWT 2 low voltage	442	4
DTC 1415 EMWT 1 higher than expected level 1	441	15
DTC 1416 EMWT 2 higher than expected level 1	442	15
DTC 1417 EMWT 1 higher than expected level 2	441	0
DTC 1418 EMWT 2 higher than expected level 2	442	0
DTC 1421 ERWT 1 high voltage	1385	3
DTC 1422 ERWT 2 high voltage	1386	3
DTC 1423 ERWT 1 low voltage	1385	4
DTC 1424 ERWT 2 low voltage	1386	4
DTC 1425 AUX Temperature 3 high	703	0
DTC 1425 AUX Temperature 3 low	703	1
DTC 1425 ERWT 1 higher than expected level 1	1385	15
DTC 1426 AUX Temperature delta T 1 high	1385	0
DTC 1426 AUX Temperature delta T 1 low	1385	1
DTC 1426 ERWT 2 higher than expected level 1	1386	15
DTC 1427 ERWT 1 higher than expected level 2	1385	0
DTC 1427 AUX Temperature 1 low	1385	1
DTC 1428 AUX Temperature 1 high	1385	0
DTC 1428 ERWT 2 higher than expected level 2	1386	0
DTC 1435 AUX Temperature 4 high	704	0
DTC 1435 AUX Temperature 4 low	704	1
DTC 1436 AUX Temperature delta T 2 high	1386	0
DTC 1436 AUX Temperature delta T 2 low	1386	1

DTC 1437 AUX Temperature 2 low	1386	1
DTC 1438 AUX Temperature 2 high	1386	0
DTC 1470 AUX Pressure 3 high	703	0
DTC 1470 AUX Pressure 3 low	703	1
DTC 1470 AUX Pressure 4 high	704	0
DTC 1470 AUX Pressure 4 low	704	1
DTC 1471 AUX Pressure delta P 1 high	1387	0
DTC 1471 AUX Pressure delta P 1 low	1387	1
DTC 1471 AUX Pressure delta P 2 high	1388	0
DTC 1471 AUX Pressure delta P 2 low	1388	1
DTC 1472 AUX Pressure 1 low	1387	1
DTC 1472 AUX Pressure 2 low	1388	1
DTC 1473 AUX Pressure 1 high	1387	0
DTC 1473 AUX Pressure 2 high	1388	0
DTC 1511 AUX analog PU1 high	701	3
DTC 1512 AUX analog PU1 low	701	4
DTC 1513 AUX analog PU2 high	702	3
DTC 1514 AUX analog PU2 low	702	4
DTC 1515 AUX analog PD1 high	710	3
DTC 1516 AUX analog PD1 low	710	4
DTC 1517 AUX analog PU3 high	703	3
DTC 1518 AUX analog PU3 low	703	4
DTC 1521 CHT higher than expected 1	110	16
DTC 1522 CHT higher than expected 2	110	0
DTC 1531 IVS/Brake/Trans-Park interlock failure	0	31
DTC 1541 AUX analog PUD1 high	704	3
DTC 1542 AUX analog PUD1 low	704	4
DTC 1543 AUX analog PUD2 high	705	3
DTC 1544 AUX analog PUD2 low	705	4
DTC 1545 AUX analog PUD3 high	706	3
DTC 1546 AUX analog PUD3 low	706	4
DTC 1547 AUX analog PUD4 high	713	3
DTC 1548 AUX analog PUD4 low	713	4
DTC 1551 AUX DIG1 high	707	3
DTC 1552 AUX DIG1 low	707	4
DTC 1553 AUX DIG2 high	708	3
DTC 1554 AUX DIG2 low	708	4
DTC 1555 Water Intrusion Detection	709	3
DTC 1555 AUX DIG3 high	709	3
DTC 1556 AUX DIG3 low	709	4
DTC 1561 AUX analog PD2 high	711	3

DTC 1562 AUX analog PD2 low	711	4
DTC 1563 AUX analog PD3 high	712	3
DTC 1564 AUX analog PD3 low	712	4
DTC 1565 AUX analog PUD5 high	0	3
DTC 1566 AUX analog PUD5 low	0	4
DTC 1567 AUX analog PUD6 high	714	3
DTC 1568 AUX analog PUD6 low	714	4
DTC 1569 AUX analog PUD7 high	715	3
DTC 1571 AUX analog PUD7 low	715	4
DTC 1572 AUX DIG4 high	716	3
DTC 1573 AUX DIG4 low	716	4
DTC 1574 AUX DIG5 high	520202	3
DTC 1575 AUX DIG5 low	520202	4
DTC 1576 AUX DIG6 high	520203	3
DTC 1577 AUX DIG6 low	520203	4
DTC 1578 AUX DIG7 high	520204	3
DTC 1579 AUX DIG7 low	520204	4
DTC 1581 AUX DIG8 high	520205	3
DTC 1582 AUX DIG8 low	520205	4
DTC 1583 AUX DIG9 high	520206	3
DTC 1584 AUX DIG9 low	520206	4
DTC 1585 AUX DIG10 high	520207	3
DTC 1586 AUX DIG10 low	520207	4
DTC 1589 AUX DIG11 high	520209	3
DTC 1591 AUX DIG11 low	520209	4
DTC 1592 AUX DIG12 high	520210	3
DTC 1593 AUX DIG12 low	520210	4
DTC 1601 Envirotech receipt lost	4490	18
DTC 1602 Relay off high voltage	1485	4
DTC 1603 Relay on low voltage	1485	4
DTC 1604 Service Interval Expired	1350	31
DTC 1611 5VE1/2 simultaneous out-of-range	1079	31
DTC 1612 RTI 1 loss	629	31
DTC 1613 RTI 2 loss	629	31
DTC 1614 RTI 3 loss	629	31
DTC 1615 A/D loss	629	31
DTC 1616 Invalid interrupt	629	31
DTC 1621 RS-485 Rx Inactive	0	31
DTC 1622 RS-485 Rx Noise	0	31
DTC 1623 RS-485 Invalid Packet Format	0	31
DTC 1624 RS-485 Shutdown Re-quest	0	31

DTC 1625 J1939 Shutdown Re-quest	1110	31
DTC 1626 CAN1 Tx failure	639	12
DTC 1627 CAN1 Rx failure	639	12
DTC 1628 CAN1 address conflict failure	639	13
DTC 1629 J1939 TSC1 message receipt lost	695	9
DTC 1630 J1939 ETC message receipt lost	91	19
DTC 1631 PWM1-Gauge1 open / ground short	697	5
DTC 1632 PWM1-Gauge1 short to power	697	3
DTC 1633 PWM2-Gauge2 open / ground short	698	5
DTC 1634 PWM2-Gauge2 short to power	698	3
DTC 1635 PWM3-Gauge3 open / ground short	699	5
DTC 1636 PWM3-Gauge3 short to power	699	3
DTC 1637 PWM4-Gauge4 open / ground short	700	5
DTC 1638 PWM4-Gauge4 short to power	700	3
DTC 1639 PWM5 open / ground short	924	5
DTC 1640 PWM5 short to power	924	3
DTC 1641 Buzzer control ground short	920	4
DTC 1642 Buzzer open	920	5
DTC 1643 Buzzer control short to power	920	3
DTC 1644 MIL control ground short	1213	4
DTC 1645 MIL control short to power	1213	3
DTC 1646 CAN2 Tx failure	1231	12
DTC 1647 CAN3 Tx failure	1235	12
DTC 1648 CAN2 Rx failure	1231	12
DTC 1649 CAN3 Rx failure	1235	12
DTC 1650 CAN2 address conflict failure	1231	13
DTC 1651 J1939 ETC message loss while in-gear	91	9
DTC 1653 CAN3 address conflict failure	1235	13
DTC 1661 PWM6 open / ground short	925	5
DTC 1662 PWM6 short to power	925	3
DTC 1663 PWM7 open / ground short	926	5
DTC 1664 PWM7 short to power	926	3
DTC 1665 PWM8 open / ground short	2646	5
DTC 1666 PWM8 short to power	2646	3
DTC 1669 PWM9 open / ground short	2647	5
DTC 1670 PWM9 short to power	2647	3
DTC 1671 Brake output open / ground short	1074	4
DTC 1672 Brake output short to power	1074	3
DTC 1673 Calibration Configuration Error	1634	13
DTC 1674 Hardware ID Failure	1634	2

DTC 1675 Start command stuck active	1675	3
DTC 1676 PWM10 open / ground short	2648	5
DTC 1677 PWM10 short to power	2648	3
DTC 1678 PWM11 open / ground short	2649	5
DTC 1679 PWM11 short to power	2649	3
DTC 1680 PWM12 open / ground short	2650	5
DTC 1681 PWM12 short to power	2650	3
DTC 1682 PWM13 open / ground short	2651	5
DTC 1683 PWM13 short to power	2651	3
DTC 1684 PWM14 open / ground short	2652	5
DTC 1685 PWM14 short to power	2652	3
DTC 1686 PWM15 open / ground short	2653	5
DTC 1687 PWM15 short to power	2653	3
DTC 1688 PWM16 open / ground short	2654	5
DTC 1689 PWM16 short to power	2654	3
DTC 1690 PWM17 open / ground short	2655	5
DTC 1691 PWM17 short to power	2655	3
DTC 1692 PWM18 open / ground short	2656	5
DTC 1693 PWM18 short to power	2656	3
DTC 1694 PWM19 open / ground short	2657	5
DTC 1695 PWM19 short to power	2657	3
DTC 1696 PWM20 open / ground short	2658	5
DTC 1697 PWM20 short to power	2658	3
DTC 1698 PWM21 open / ground short	2659	5
DTC 1699 PWM21 short to power	2659	3
DTC 1700 PWM22 open / ground short	2660	5
DTC 1701 PWM22 short to power	2660	3
DTC 1702 PWM23 open / ground short	2661	5
DTC 1703 PWM23 short to power	2661	3
DTC 2111 Unable to reach lower TPS	51	7
DTC 2112 Unable to reach higher TPS	51	7
DTC 2115 FPP1 higher than IVS limit	91	0
DTC 2116 FPP2 higher than IVS limit	29	0
DTC 2120 FPP1 invalid voltage and FPP2 disagrees with IVS (redundancy lost)	520199	11
DTC 2121 FPP1 lower than FPP2	91	18
DTC 2122 FPP1 high voltage	91	3
DTC 2123 FPP1 low voltage	91	4
DTC 2125 FPP2 invalid voltage and FPP1 disagrees with IVS (redundancy lost)	520199	11
DTC 2126 FPP1 higher than FPP2	91	16

DTC 2127 FPP2 low voltage	29	4
DTC 2128 FPP2 high voltage	29	3
DTC 2130 IVS stuck at-idle, FPP1/2 match	558	5
DTC 2131 IVS stuck off-idle, FPP1/2 match	558	6
DTC 2135 TPS1/2 simultaneous voltages out of range	51	31
DTC 2139 FPP1 lower than IVS limit	91	1
DTC 2140 FPP2 lower than IVS limit	29	1
DTC 2229 BP high pressure	108	0
DTC 2261 1 CR Injector High-Side Short to Ground	2651	5
DTC 2262 1 CR Injector Low-Side Short to Power	2651	3
DTC 2264 2 CR Injector High-Side Short to Ground	2652	5
DTC 2265 2 CR Injector Low-Side Short to Power	2652	3
DTC 2267 3 CR Injector High-Side Short to Ground	2653	5
DTC 2268 3 CR Injector Low-Side Short to Power	2653	3
DTC 2270 4 CR Injector High-Side Short to Ground	2654	5
DTC 2271 4 CR Injector Low-Side Short to Power	2654	3
DTC 2273 5 CR Injector High-Side Short to Ground	2655	5
DTC 2274 5 CR Injector Low-Side Short to Power	2655	3
DTC 2276 6 CR Injector High-Side Short to Ground	2656	5
DTC 2277 6 CR Injector Low-Side Short to Power	2656	3
DTC 2279 7 CR Injector High-Side Short to Ground	2657	5
DTC 2280 7 CR Injector Low-Side Short to Power	2657	3
DTC 2282 8 CR Injector High-Side Short to Ground	2658	5
DTC 2283 8 CR Injector Low-Side Short to Power	2658	3
DTC 2295 Secondary FP low volt- age	94	4
DTC 2296 Secondary FP high voltage	94	3
DTC 2300 1 Primary Loop Open or Low-Side Short to Ground	1268	5
DTC 2301 1 Primary Coil Shorted	1268	6
DTC 2303 2 Primary Loop Open or Low-Side Short to Ground	1269	5
DTC 2304 2 Primary Coil Shorted	1269	6
DTC 2306 3 Primary Loop Open or Low-Side Short to Ground	1270	5
DTC 2307 3 Primary Coil Shorted	1270	6



DTC 2309 4 Primary Loop Open or Low-Side Short to Ground	1271	5
DTC 2310 4 Primary Coil Shorted	1271	6
DTC 2312 5 Primary Loop Open or Low-Side Short to Ground	1272	5
DTC 2313 5 Primary Coil Shorted	1272	6
DTC 2315 6 Primary Loop Open or Low-Side Short to Ground	1273	5
DTC 2316 6 Primary Coil Shorted	1273	6
DTC 2318 7 Primary Loop Open or Low-Side Short to Ground	1274	5
DTC 2319 7 Primary Coil Shorted	1274	6
DTC 2321 8 Primary Loop Open or Low-Side Short to Ground	1275	5
DTC 2322 8 Primary Coil Shorted	1275	6
DTC 2324 9 Primary Loop Open or Low-Side Short to Ground	1276	5
DTC 2325 9 Primary Coil Shorted	1276	6
DTC 2327 10 Primary Loop Open or Low-Side Short to Ground	1277	5
DTC 2328 10 Primary Coil Shorted	1277	6
DTC 2428 Exhaust gas tempera- ture high	173	0
DTC 2618 Tach output ground short	645	4
DTC 2619 Tach output short to power	645	3
DTC 2665 CFV RLV test failed	3601	7
DTC 3001 1 Glow Plug Open/Power Short	2899	3
DTC 3002 2 Glow Plug Open/Power Short	2899	3
DTC 3003 3 Glow Plug Open/Power Short	2899	3
DTC 3004 4 Glow Plug Open/Power Short	2899	3
DTC 3005 5 Glow Plug Open/Power Short	2899	3
DTC 3006 6 Glow Plug Open/Power Short	2899	3
DTC 3007 7 Glow Plug Open/Power Short	2899	3
DTC 3008 8 Glow Plug Open/Power Short	2899	3
DTC 3009 9 Glow Plug Open/Power Short	2899	3
DTC 3010 10 Glow Plug Open/Power Short	2899	3
DTC 3011 UEGO1 internal processor fault	3221	31
DTC 3012 UEGO1 heater supply high voltage	3222	3
DTC 3013 UEGO1 heater supply low voltage	3222	4
DTC 3014 UEGO1 cal resistor voltage high	3221	3
DTC 3015 UEGO1 cal resistor voltage low	3221	4
DTC 3016 UEGO1 return voltage shorted high	3056	3
DTC 3017 UEGO1 return voltage shorted low	3056	4
DTC 3018 UEGO1 pump voltage shorted high	3218	3
DTC 3019 UEGO1 pump voltage shorted low	3218	4
DTC 3020 UEGO1 sense cell volt- age high	3217	3

DTC 3021 UEGO1 sense cell volt- age low	3217	4
DTC 3022 UEGO1 pump voltage at high drive limit	3225	3
DTC 3023 UEGO1 pump voltage at low drive limit	3225	4
DTC 3024 UEGO1 sense cell slow to warm up	3222	10
DTC 3025 UEGO1 pump cell slow to warm up	3225	10
DTC 3026 UEGO1 sense cell impedance high	3222	0
DTC 3027 UEGO1 pump cell impedance high	3225	0
DTC 3028 UEGO1 pump cell impedance low	3225	1
DTC 3029 UEGO1 drift is out-of- tolerance	3221	15
DTC 3030 UEGO1 drift is out-of- tolerance - level 2	3221	16
DTC 3031 UEGO1 heater open / ground short	3222	4
DTC 3032 UEGO1 heater short to power	3222	3
DTC 3033 UEGO2 internal processor fault	3260	31
DTC 3034 UEGO2 drift is out-of- tolerance	3260	15
DTC 3035 UEGO2 drift is out-of- tolerance - level 2	3260	16
DTC 3036 UEGO2 heater supply high voltage	3261	3
DTC 3037 UEGO2 heater supply low voltage	3261	4
DTC 3038 UEGO2 cal resistor voltage high	3260	3
DTC 3039 UEGO2 cal resistor voltage low	3260	4
DTC 3040 UEGO2 return voltage shorted high	3057	3
DTC 3041 UEGO2 return voltage shorted low	3057	4
DTC 3042 UEGO2 pump voltage shorted high	3257	3
DTC 3043 UEGO2 pump voltage shorted low	3257	4
DTC 3044 UEGO2 sense cell volt- age high	3256	3
DTC 3045 UEGO2 sense cell volt- age low	3256	4
DTC 3046 UEGO2 pump voltage at high drive limit	3264	3
DTC 3047 UEGO2 pump voltage at low drive limit	3264	4
DTC 3048 UEGO2 sense cell slow to warm up	3261	10
DTC 3049 UEGO2 pump cell slow to warm up	3264	10
DTC 3050 UEGO2 sense cell impedance high	3261	0
DTC 3051 UEGO2 pump cell impedance high	3264	0
DTC 3052 UEGO2 pump cell impedance low	3264	1
DTC 3053 UEGO2 heater open / ground short	3261	4
DTC 3054 UEGO2 heater short to power	3261	3

DTC 3100 CR Injection Bank Boost Voltage Low, Bank 1	3100	4
DTC 3101 CR Injection Bank Boost Voltage Low, Bank 2	3101	4
DTC 3102 CR Injection Bank Internal Fault, Bank 1	3102	31
DTC 3103 CR Injection Bank Internal Fault, Bank 2	3103	31
DTC 3104 IMV Loop Open or Short to Ground	3104	5
DTC 3105 IMV Coil Short or Short to Power	3105	6
DTC 3999 DBW drive current high	0	6
DTC 3999 HBA drive current high	0	6
DTC 3999 HBB drive current high	0	6
DTC 3999 AUX analog PUD8 high	0	31
DTC 3999 AUX analog PUD8 low	0	31
DTC 3999 AUX analog PUD9 high	0	31
DTC 3999 AUX analog PUD9 low	0	31
DTC 3999 AUX analog PUD10 high	0	31
DTC 3999 AUX analog PUD10 low	0	31
DTC 3999 AUX analog PUD11 high	0	31
DTC 3999 AUX analog PUD11 low	0	31
DTC 3999 AUX analog PUD12 high	0	31
DTC 3999 AUX analog PUD12 low	0	31
DTC 3999 AUX analog PUD13 high	0	31
DTC 3999 AUX analog PUD13 low	0	31
DTC 3999 AUX analog PUD14 high	0	31
DTC 3999 AUX analog PUD14 low	0	31
DTC 3999 AUX analog PUD15 high	0	31
DTC 3999 AUX analog PUD15 low	0	31
DTC 3999 AUX analog PUD16 high	0	31
DTC 3999 AUX analog PUD16 low	0	31
DTC 3999 AUX analog PUD17 high	0	31
DTC 3999 AUX analog PUD17 low	0	31
DTC 3999 AUX analog PUD18 high	0	31
DTC 3999 AUX analog PUD18 low	0	31

DTC 3999 AUX analog PUD19 high	0	31
DTC 3999 AUX analog PUD19 low	0	31
DTC 3999 AUX analog PUD20 high	0	31
DTC 3999 AUX analog PUD20 low	0	31
DTC 3999 AUX analog PUD21 high	0	31
DTC 3999 AUX analog PUD21 low	0	31
DTC 3999 AUX analog PUD22 high	0	31
DTC 3999 AUX analog PUD22 low	0	31
DTC 3999 AUX analog PUD23 high	0	31
DTC 3999 AUX analog PUD23 low	0	31
DTC 3999 AUX analog PUD24 high	0	31
DTC 3999 AUX analog PUD24 low	0	31
DTC 3999 AUX analog PUD25 high	0	31
DTC 3999 AUX analog PUD25 low	0	31
DTC 3999 AUX DIG13 high	0	31
DTC 3999 AUX DIG13 low	0	31
DTC 3999 AUX DIG14 high	0	31
DTC 3999 AUX DIG14 low	0	31
DTC 3999 AUX DIG15 high	0	31
DTC 3999 AUX DIG15 low	0	31
DTC 3999 AUX DIG16 high	0	31
DTC 3999 AUX DIG16 low	0	31
DTC 3999 AUX DIG17 high	0	31
DTC 3999 AUX DIG17 low	0	31
DTC 3999 AUX DIG18 high	0	31
DTC 3999 AUX DIG18 low	0	31
DTC 3999 AUX DIG19 high	0	31
DTC 3999 AUX DIG19 low	0	31
DTC 3999 AUX DIG20 high	0	31
DTC 3999 AUX DIG20 low	0	31
DTC 3999 AUX DIG21 high	0	31
DTC 3999 AUX DIG21 low	0	31
DTC 3999 AUX DIG22 high	0	31
DTC 3999 AUX DIG22 low	0	31
DTC 3999 AUX DIG23 high	0	31

DTC 3999 AUX DIG23 low	0	31
DTC 3999 AUX DIG24 high	0	31
DTC 3999 AUX DIG24 low	0	31
DTC 3999 AUX DIG25 high	0	31
DTC 3999 AUX DIG25 low	0	31
DTC 3999 UEGO1 internal supply voltage low	0	31

DTC 3999 UEGO2 internal supply voltage low	0	31
DTC 3999 Cooling water flow lower than expected	110	1
DTC 3999 Catalyst monitor - exhaust P low	4755	1
DTC 3999 Catalyst monitor - exhaust P high	4755	0

## OBD System Check/MIL (Malfunction Indicator Lamp)

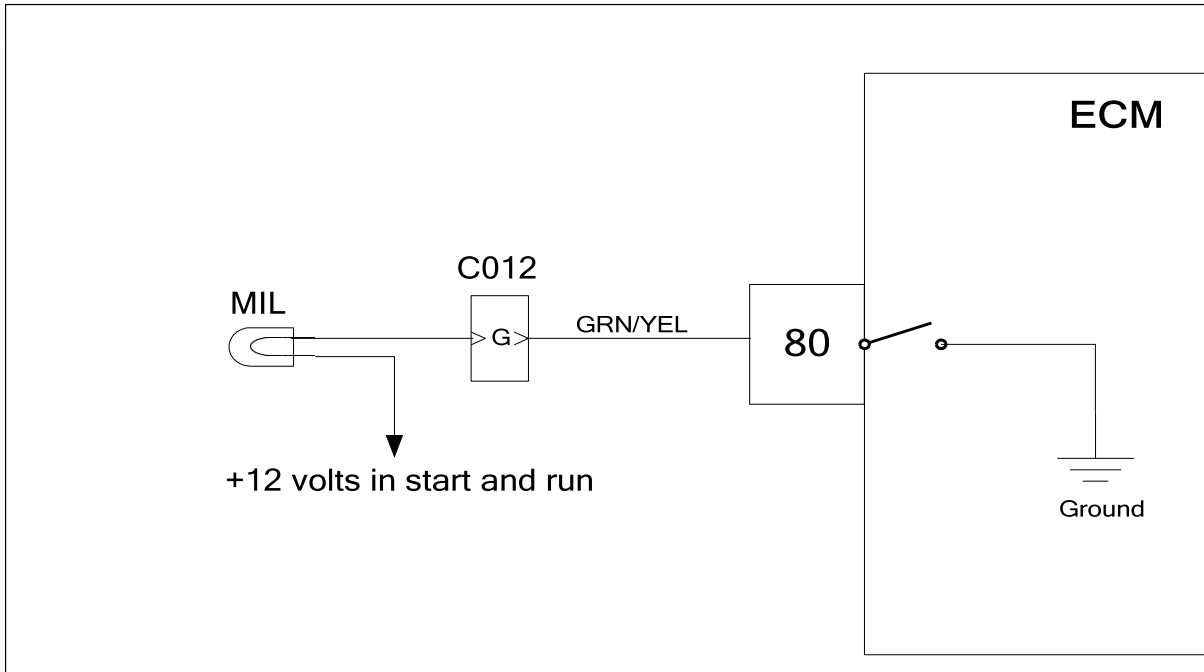

### **Circuit Description**

The fuel system is equipped with OBD (On-Board Diagnostics). The system has a dash mounted MIL (Malfunction Indicator Lamp). The MIL serves as notification of an engine or fuel system related problem. The MIL also has the ability to flash DTC codes in what is referred to as the blink code mode. It will display DTCs that have been stored due to a possible system malfunction. The following DTC charts in this manual will instruct the technician to perform the OBD system check. This simply means to verify the operation of the MIL. The lamp should illuminate when the key is in the ON position, and the engine is not running. This feature verifies that the lamp is in proper working order. If the lamp does not illuminate with the vehicle key ON and engine OFF, repair it as soon as possible. Once the engine is in start or run mode, the lamp should go off. If the lamp stays on while the engine is in the start or run mode, a current diagnostic trouble code may be set, or a problem may exist with the MIL electrical wiring. The electrical schematic above shows the MIL power source supplied to the lamp. The ECM completes the circuit to ground to turn the lamp ON.

## OBD System Check

Step	Action	Value(s)	Yes	No
1	Key ON engine Off		Go to Step (2)	Go to Step (3)
2	<ul style="list-style-type: none"> <li>Start the engine</li> <li>Does the MIL Lamp Turn off?</li> </ul>		MIL is working properly. OBD SystemCheck is complete	Go to Step (10)
3	<ul style="list-style-type: none"> <li>Key ON engine OFF</li> <li>Check for voltage between MIL power source and engine ground.</li> </ul> <input type="checkbox"/> <p>Do you have voltage?</p>		Go to Step (4)	Repair MIL voltage source. Referto OEM body and chassis wiring diagrams
4	Replace the MIL Lamp Did that solve the problem?		Go to Step (1)	Go to Step (5)
5	<ul style="list-style-type: none"> <li>Key OFF</li> <li>Disconnect ECM wire harness connector</li> <li>Using a DVOM check for continuity between MIL side of the customer interface connector and ECM pin 80</li> </ul> Do you have continuity?		Go to Step (6)	Go to Step (8)
6	<ul style="list-style-type: none"> <li>Inspect the MIL lamp socket, the customer interface connector, and ECM pin 80 for damage, corrosion, or contamination</li> </ul> Did you find a problem?		Repair the circuit as necessary. Refer to wiring repairs section in the manual	Go to Step (7)
7	<ul style="list-style-type: none"> <li>Replace ECM</li> </ul> <input type="checkbox"/> <p>Is the replacement complete?</p>		Go to Step (1)	-
8	<ul style="list-style-type: none"> <li>Back probe both MIL and ECM side of terminal G at the customer interface connector</li> <li>Using a DVOM check for continuity through the customer interface connector</li> </ul> Do you have continuity?		Go to Step (9)	Repair the open circuit
9	<ul style="list-style-type: none"> <li>Inspect the MIL lamp socket, customer interface connector, and ECM terminal number 80 for damage, corrosion, or contamination</li> </ul> Did you find a problem?		Repair the damaged socket or terminal as required	Repair the wire harness open circuit as necessary

Step	Action	Value(s)	Yes	No
10	Active DTC (Diagnostic Trouble Code) is stored in memory. Proceed with DTC diagnosis. If no active DTC is found in ECM memory return to this page step (11)			
11	<ul style="list-style-type: none"> <li>• Key is off</li> <li>• Disconnect ECM wire harness connector at customer interface connector</li> <li>• Using a DVOM check for continuity between ECM terminal 80 and battery voltage</li> </ul> <input type="checkbox"/> Do you have continuity?		Repair the shorted ground circuit as necessary. Refer to wiring re-pairs in engine electrical	Go to Step (7)

## Starter Circuit System Diagnostics

STEP	Action	Value(s)	Yes	No
1	Remove the back off of the fuse and relay block assembly. Locate and inspect all wires/terminals for the starter relay circuit. Ensure that all crimps are good and that all terminals are completely engaged into the block. Look for push back terminals or bad crimps.	All Okay	Go to Step (2)	Repair the Wiring issue.
2	<ul style="list-style-type: none"> <li>Using a DVOM, back probe the starter relay coil terminal 85 to a +12V while cranking the engine.</li> </ul> <p>Does the DVOM have a 12v signal while cranking?</p>	12v	Go to Step (3)	Check wire from the relay terminal 85 to on 89 on the ECM. Check all terminals for spread condition or push back. Repair harness.
3	<ul style="list-style-type: none"> <li>Using a DVOM, back probe the starter relay coil terminal 86 to a Ground source while cranking the engine.</li> </ul> <p>Does the DVOM have a 12v signal while cranking?</p>	12v	Go to Step (4)	Go 1 step (6)
4	<ul style="list-style-type: none"> <li>Using a DVOM, back probe starter relay contactfeed terminal 87 to a Ground source</li> </ul> <p>Does the DVOM have a 12v signal at all times?</p>	12V	Go to Step (5)	Go to step (7)
5	<ul style="list-style-type: none"> <li>Using a DVOM, back probe relay contact terminal 30 to a Ground source</li> </ul> <p>Does the DVOM have a 12v signal while cranking?</p>	12V	Go to Step (8)	Replace starter relay
6	<ul style="list-style-type: none"> <li>Check terminals at the CIC pin F and terminal 86at the relay.</li> <li>Check for continuity between pin F at terminal 86of the relay.</li> </ul> <p>Do you have continuity? Are the pins fully seatedand not spread?</p>	Yes	Issue with switched 12v supply from OEM. Consult OEM	Repair the wiring issue.
7	<ul style="list-style-type: none"> <li>Check circuit between terminal 87 and the 20A starter fuse.</li> <li>Check for pushed back pins, broken, or cracked fuses.</li> </ul> <p>Did the circuit have a fault between terminal 87 andthe 20A fuse?</p>		Repair the fault in the circuit	Possible internal harness issue.

STEP	Action	Value(s)	Yes	No
8	<ul style="list-style-type: none"> <li>• Check circuit between terminal 30 at the relay and the starter solenoid.</li> <li>• Check terminal 30 for spread terminals and pushback.</li> </ul> <p>Is the circuit between terminal 30 and the starter okay?</p>		Replace Starter	Repair the wiring issue.



## HVS Ignition Control System Diagnostics

### 4.3L, 5.0L, 5.7L - SHOWN BELOW

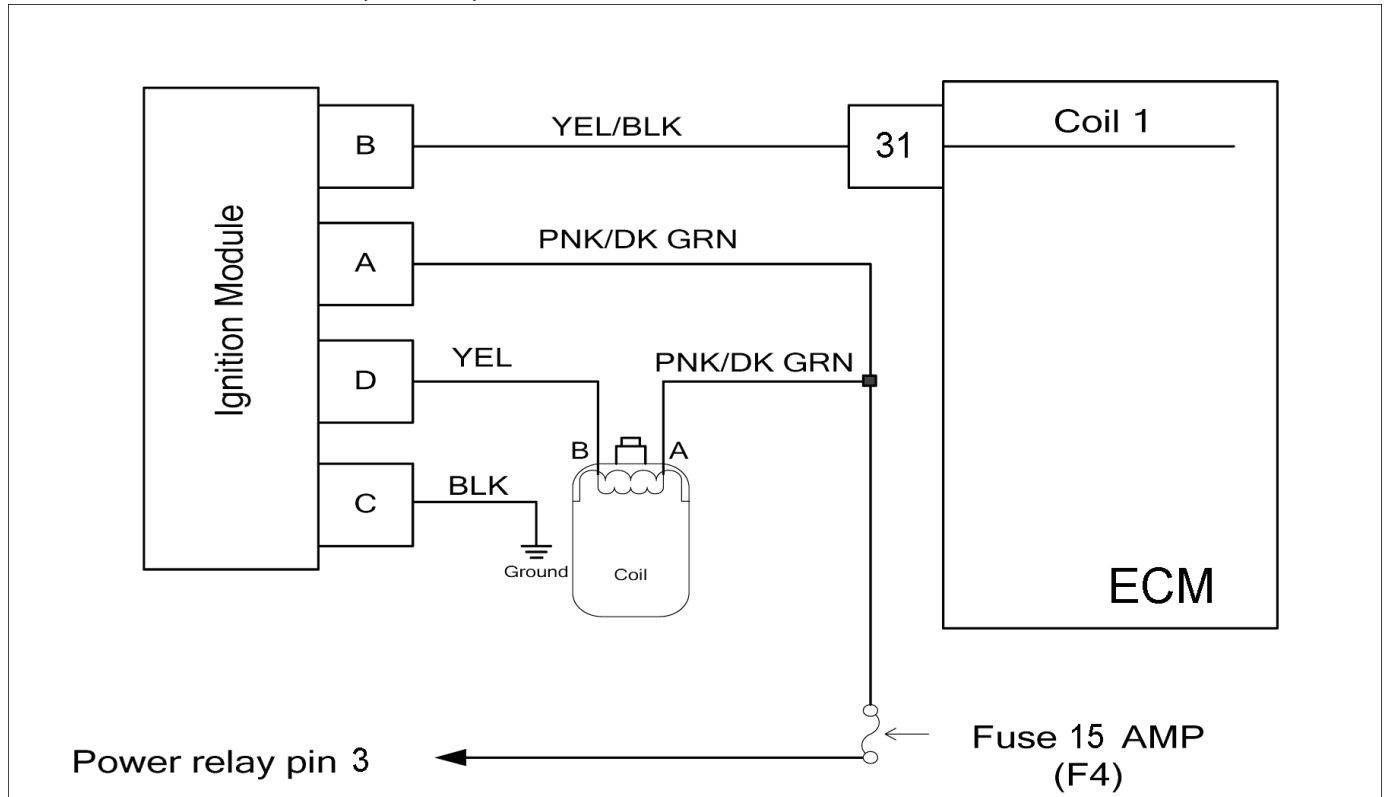

**Before using the Ignition, Control Diagnostic chart be sure to check the following items:**

#### **Spark plug wires:**

Be sure spark plug wires are in good condition. Check for cuts, breaks, burns, hardness or swelling. LPG fuel requires much higher peak firing voltages compared to gasoline. Check spark plug electrical continuity using a DVOM. Wires should ohm out to no more than 1,000 ohms per foot of wire length.

#### **Distributor cap and rotor:**

Check the cap and rotor assembly for moisture, corrosion, or carbon tracking. The ignition timing is not adjustable. Turning the distributor assembly will not change the ignition timing but will alter the rotor phase. Wipe away dust and debris from the ignition coil tower.

#### **System power fuses:**

Check the system power fuses. These sources supply the ignition coil and module system power. Check that the power and ground terminals are clean and in the proper location.

## Ignition Control System Diagnostic Chart

Step	Action	Value(s)	Yes	No
1	Did you perform the On-Board (OBD) System Check?	-	Go to Step (2)	Go to OBD System Check Section
2	<ul style="list-style-type: none"> <li>DST connected and in the system data mode.</li> <li>Crank the engine and observe the enginespeed signal on the DST</li> </ul> Is the value greater than the specified value?	125 RPM	Go to Step (5)	Go to Step (3)
3	<ul style="list-style-type: none"> <li>Check the DST for historical code sets. (Always diagnose and repair codes with the lowest numerical value first).</li> <li>Run the diagnostic chart for DTC 337Did you find and correct the problem?</li> </ul>		Go to Step (16)	Go to Step (4)
4	<ul style="list-style-type: none"> <li>Run the diagnostic chart for DTC 342Did you find and correct the problem?</li> </ul>		Go to Step (16)	Go to Step (5)
5	<ul style="list-style-type: none"> <li>Disconnect the ignition module connector C011</li> <li>Using an LED type test lamp check for a signal between the ignition module connector pin B and battery positive</li> <li>Crank the engine</li> </ul> Does the LED test lamp flash while cranking the engine?		Go to Step (6)	Go to Step (10)
6	<ul style="list-style-type: none"> <li>Using a DVOM check for power between the ignition module connector pin A and engine ground</li> </ul> Do you have power?		Go to Step (7)	Repair the system power circuit. Check all system fuses and power relay connections
7	<ul style="list-style-type: none"> <li>Disconnect the ignition coil connector C009</li> <li>Using a digital LED test lamp check for a signal between the ignition coil connector pin B and battery positive</li> <li>Crank the engine</li> </ul> Does the LED test lamp flash while cranking the engine?		Go to Step (8)	Go to Step (13)
8	<ul style="list-style-type: none"> <li>Using a DVOM check for voltage between the ignition coil connector pin A and engine ground</li> </ul> Does the DVOM show voltage?	System voltage	Go to Step (9)	Repair the system power circuit. Check all system fuses and power relay connections
9	<ul style="list-style-type: none"> <li>Replace the ignition coil</li> </ul> Is the replacement complete?		Go to Step (16)	-

Step	Action	Value(s)	Yes	No
10	<ul style="list-style-type: none"> <li>Key OFF</li> <li>Disconnect the ECM connector C001</li> <li>Using a DVOM check for continuity between ignition module connector pin B and ECM connector pin 31</li> </ul> Do you have continuity between them?		Go to Step (11)	Repair the open ignition control circuit. See wiring harness repair section.
11	<ul style="list-style-type: none"> <li>Using a DVOM check for continuity between ignition module connector pin B and engine ground</li> </ul> Do you have continuity between them?		Repair the shorted to ground ignition control circuit. See wiring harness repair section.	Go to Step (12)
12	<ul style="list-style-type: none"> <li>Replace ECM</li> </ul> Is the replacement complete?		Go to Step (16)	-
13	<ul style="list-style-type: none"> <li>Disconnect coil. Using a DVOM check for continuity between the ignition module connector pin C and engine ground</li> </ul> Do you have continuity?		Go to Step (14)	Repair the open ignition module ground circuit. See wiring harness repair.
14	<ul style="list-style-type: none"> <li>Using a DVOM check for continuity between the ignition module connector pin D and ignition coil connector pin B</li> </ul> Do you have continuity?		Go to Step (15)	Repair the open ignition module circuit. See wiring harness repair.
15	<ul style="list-style-type: none"> <li>Replace the ignition module.</li> </ul> Is the replacement complete?		Go to Step (16)	-
16	<ul style="list-style-type: none"> <li>Remove all test equipment except the DST.</li> <li>Connect any disconnected components, fuses, etc.</li> <li>Using the DST clear DTC information from the ECM.</li> <li>Turn the ignition OFF and wait 30 seconds.</li> <li>Start the engine and operate the vehicle to full operating temperature</li> <li>Observe the MIL</li> <li>Observe engine performance and drivability.</li> <li>After operating the engine check for any stored codes.</li> </ul> Does the engine operate normally with no stored codes?		System OK	Go to OBD System Check

## DTC 11 – Distributor Alignment Out of Spec (SPN 520800:FMI 7)

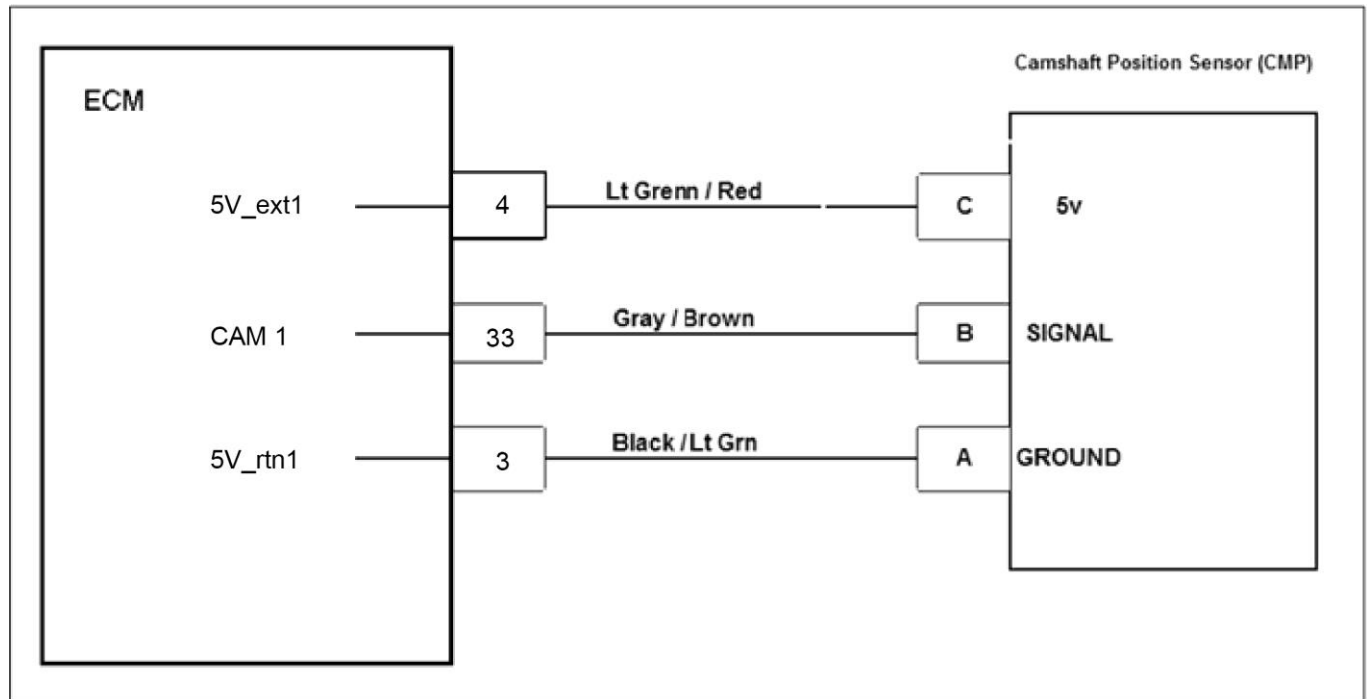

### Conditions for setting the DTC

- Camshaft Position sensor
- Check Condition- Engine cranking
- Fault Condition - Difference between the desired CAM position (Distributor Alignment) and actual CAM position (Distributor Alignment) is greater than 30 CAD
- MIL Command-ON

### Circuit Description

The CAM position sensor is utilized to distinguish the cylinder event (compression or exhaust), thus making the cylinder identification available to the ECM. The camshaft position sensor is a 3-wire hall effect sensor. One wire for current feed (5v), one for ground, and one for the output signal (CAM 1). The sensor must have a good 5v reference and ground to operate properly. The cam sensor is located inside the HVS Distributor

The CAM position and CAM Position desired value is displayed on the "TESTS" page in the GCP display software. This code will set when these two values are more than 30 CAD apart.

To change the CAM position, you should rotate the distributor. If rotating the distributor does not correct the issue you should troubleshoot sensor, wiring, and ECM for issues.

**3.0L Desired Distributor Position → 340 CAD**

**4.3L Desired Distributor Position → 6 CAD**

**5.7L Desired Distributor Position → 11 CAD**

## **DTC 16 – Never Crank Synchronized at Start (SPN 636:FMI 8)**

**(4.3L, 5.0, & 5.7L Shown Below)**

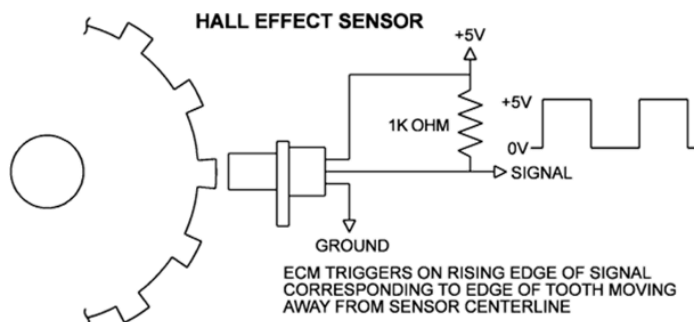
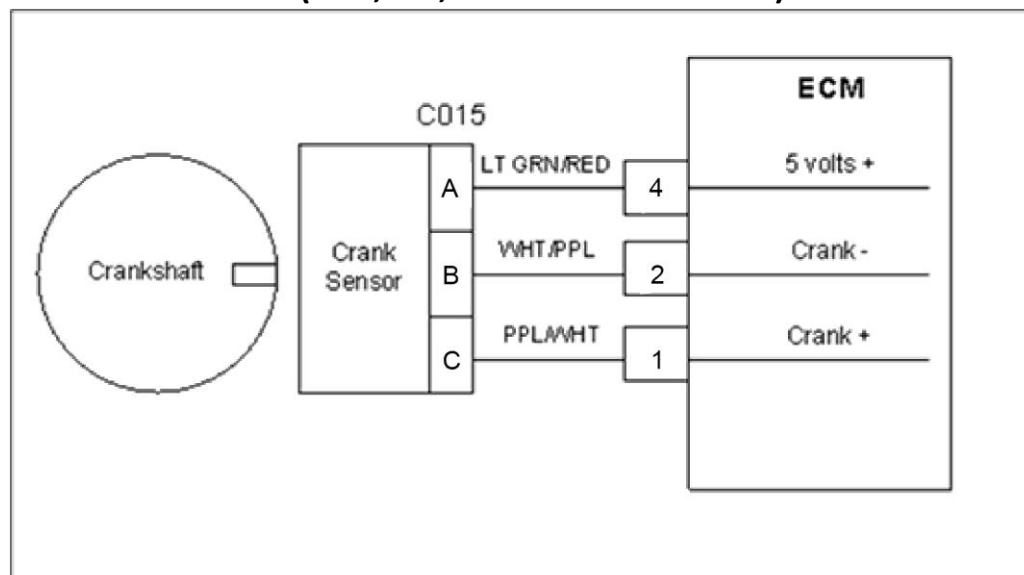

### **Conditions for setting the DTC**

- Crankshaft Position sensor
- Check Condition- Engine cranking
- Fault Condition- Cranking rpm above 90 and more than 4 cranking revolutions without synchronization
- Adaptive Disabled
- MIL Command-ON

### **Circuit Description**

The Crankshaft position sensor is a 5-volt powered sensor mounted to the lower front engine block. A pulse wheel located on the crankshaft is used to measure engine rpm and its signal is used to synchronize the ignition and fuel systems. This fault will set if the ECM detects cranking revolutions without synchronization of the CMP and CKP sensors.

Reversed sensor wires, poor wire connections or a faulty system ground are most frequently the cause of this code set.

Step	Action	Value(s)	Yes	No
1	Did you perform the On-Board (OBD) System Check?	-	Go to Step (2)	Go to OBD System Check Section
2	<ul style="list-style-type: none"> <li>Check that the ECM ground terminals C010, C022 and C023 are clean and tight</li> </ul> Are the ground terminals clean and tight?		Go to Step (3)	Repair the circuit as necessary. Referto Wiring Re- pairs in Engine Electrical.
3	<ul style="list-style-type: none"> <li>Key On, Engine OFF</li> <li>Disconnect the CKP (Crankshaft position)Sensor connector C015</li> <li>Using A DVOM check for voltage at the CKP sensor connector pin A and engine ground</li> </ul> <b>(CHECK THIS BEFORE THE POWER RELAYSHUTS OFF)</b> Do you have voltage?	5.0 volts	Go to Step (4)	Repair the circuit as necessary. Refer toWiring Repairs in Engine Electrical.
4	<ul style="list-style-type: none"> <li>Key OFF</li> <li>Disconnect ECM connector C001</li> <li>Using a DVOM check for continuity between CKP connector pin B and ECM connector pin 2</li> </ul> Do you have continuity between them?		Go to Step (5)	Repair the circuit as necessary. Referto Wiring Re- pairs in Engine Electrical.
5	<ul style="list-style-type: none"> <li>Using a DVOM check for continuity between CKP connector pin C and ECM connector pin 1</li> </ul> Do you have continuity between them?		Go to Step (6)	Repair the circuit as necessary. Referto Wiring Repairs in Engine Electrical.
6	<ul style="list-style-type: none"> <li>Inspect the CKP connector C015 terminals for damage, corrosion or contamination</li> </ul> Did you find a problem?		Repair the circuit as necessary. Referto Wiring Repairs in Engine Electrical.	Go to Step (7)
7	<ul style="list-style-type: none"> <li>Inspect the ECM connector C001 terminals 4, 2 and 1 for damage, corrosion or contamination</li> </ul> Did you find a problem?		Repair the circuit as necessary. Referto Wiring Repairs in Engine Electrical.	Go to step (8)

Step	Action	Value(s)	Yes	No
8	<ul style="list-style-type: none"> <li>Replace CKP sensor</li> </ul> Is the replacement complete?		Go to Step (10)	-
9	<ul style="list-style-type: none"> <li>Replace ECM</li> </ul> Is the replacement complete?		Go to Step (11)	-
10	<ul style="list-style-type: none"> <li>Remove all test equipment except the DST.</li> <li>Connect any disconnected components, fuses, etc.</li> <li>Using the DST clear DTC information from the ECM.</li> <li>Turn the ignition OFF and wait 30 seconds.</li> <li>Start the engine and operate the vehicle to full operating temperature</li> <li>Observe the MIL</li> <li>Observe engine performance and drivability</li> <li>After operating the engine within the test parameters of DTC-16 check for any stored codes.</li> </ul> Does the engine operate normally with no stored codes?		System OK	Go to Step (9)
11	<ul style="list-style-type: none"> <li>Remove all test equipment except the DST.</li> <li>Connect any disconnected components, fuses, etc.</li> <li>Using the DST clear DTC information from the ECM.</li> <li>Turn the ignition OFF and wait 30 seconds.</li> <li>Start the engine and operate the vehicle to full operating temperature</li> <li>Observe the MIL</li> <li>Observe engine performance and drivability</li> <li>After operating the engine within the test parameters of DTC-16 check for any stored codes.</li> </ul> Does the engine operate normally with no stored codes?		System OK	Go to OBD System Check

## **DTC 16-Never Crank Synced At Start (3.0L ONLY) (SPN 636:FMI 8)**

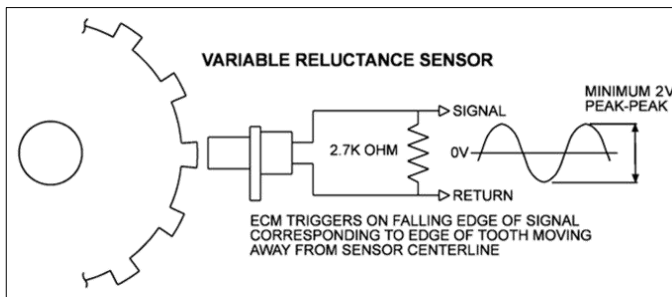
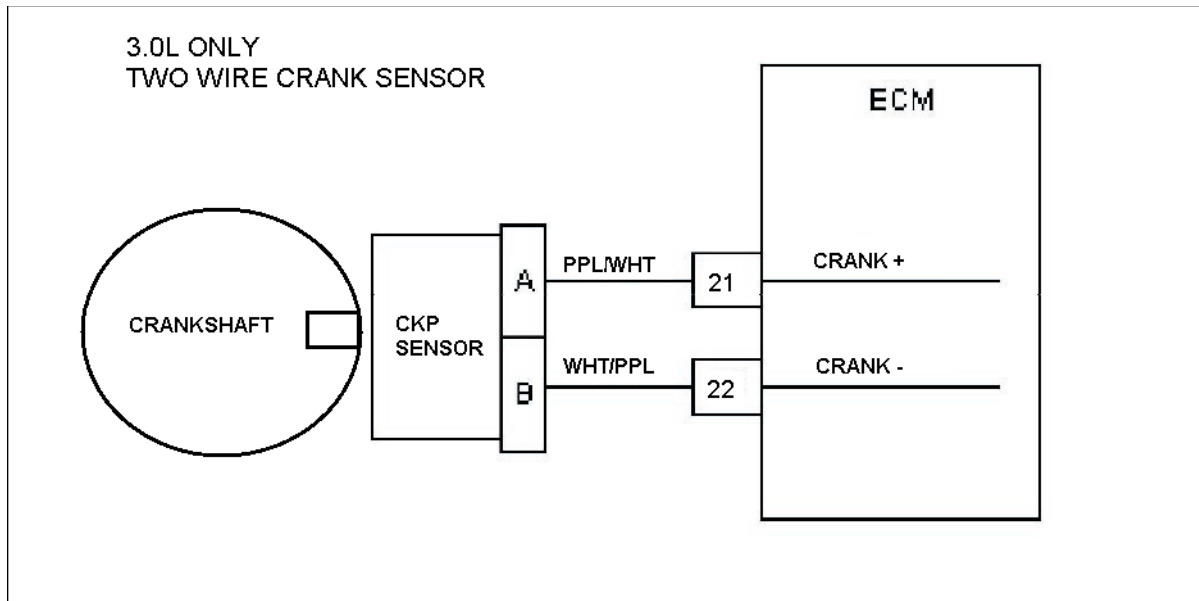

### **Conditions for setting the DTC**

- Crankshaft Position sensor
- Check Condition- Engine cranking
- Fault Condition- Cranking RPM above 90 and more than 4 cranking revolutions without sync
- MIL Command-ON

**NOTE: The 3.0L engine has a 2 wire Variable Reluctance Sensor**

### **Circuit Description**

The CKP (crankshaft position sensor) is a magnetic transducer mounted on the engine block adjacent to a pulse wheel located on the crankshaft. It determines crankshaft position by monitoring the pulse wheel. The Crankshaft Position sensor is used to measure engine RPM and its signal is used to synchronize the ignition and fuel systems. This fault will set one or more crank re-sync occur within 800 ms.



Step	Action	Value(s)	Yes	No
1	Did you perform the On-Board (OBD) System Check?		Go to Step (2)	Go to OBD System CheckSection
2	Check to be sure that the ECM ground terminals CO14 and CO23 are clean and tight.  Are terminals CO14 and CO23 clean and tight?		Go to Step (3)	Repair the circuit as necessary. Refer to wiring Repairs in Engine Electrical.
3	Key OFF Disconnect the CKP sensor connector CO17 Using a DVOM check for voltage output directlyfrom the CKP sensor while cranking the engine Do you have voltage output?	Over .5 Volts	Go to Step (4)	Go to Step (11)
4	Key OFF Disconnect ECM connector C001 Using a DVOM check for continuity between CKP connector pin A and ECM connector pin 21Do you have continuity between them?		Go to Step (5)	Repair the circuit as necessary. Refer to Wiring Repairs in Engine Electrical
5	Using a DVOM check for continuity between CKP connector pin B and ECM connector pin 22  Do you have continuity between them?		Go to Step (6)	Repair the circuit as necessary. Refer to Wiring Repairs in Engine Electrical
6	Inspect the CKP connector C017 pins for dam-age, corrosion or contamination  Did you find a problem?		Repair the circuit as necessary. Refer to Wiring Repairs in Engine Electrical	Go to Step (7)
7	Inspect the ECM connector C001 pins 21 and 22Did you find a problem?		Repair the circuit as necessary. Refer to Wiring Repairs in Engine Electrical	Go to Step (8)
8	Using a DVOM check for continuity between ECM connector pins 21 and 22 to engine ground  Do you have continuity?		Repair the shorted circuit as necessary. Refer to Wiring Repairs in Engine Electrical	Go to Step (10)

Step	Action	Value(s)	Yes	No
9	Replace CKP sensor		Go to Step (12)	-
10	Replace ECM Is the replacement complete?		Go to Step (12)	-
11	Key OFF Inspect the pulse wheel and CKP sensor for mechanical damage, corrosion or contamination.  Did you find a problem?		Repair the component as necessary. Refer to Engine Repairs in Engine Section	Go to Step (9)
12	Remove all test equipment except the DST. Connect any disconnected components, fuses, etc.Using the DST clear DTC information from the ECM. Turn the ignition OFF and wait 30 seconds. Start the engine and operate the vehicle to full operating temperature Observe the MIL Observe engine performance and drivability After operating the engine within the test parameters of DTC-16 check for any stored codes.  Does the engine operate normally with no stored codes?		System OK	Go to OBD System Check

## DTC 31 – EGOH1 Open / Ground Short

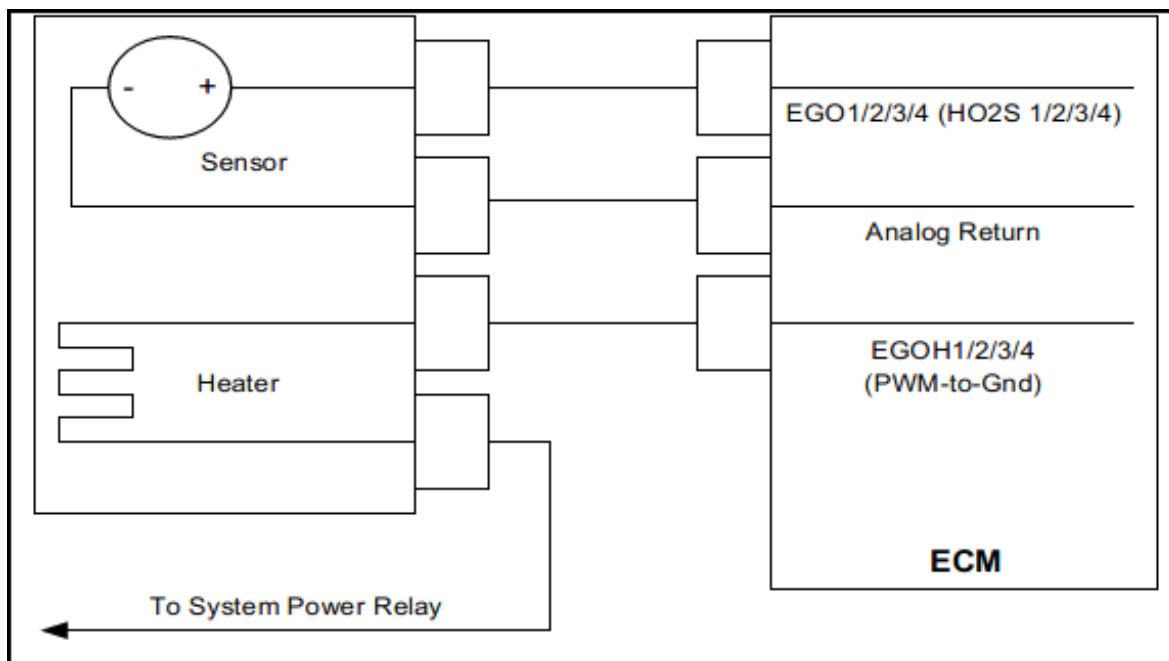

### Conditions for Setting the DTC

- Check Condition: Key-On, Engine Cranking or Running
- Fault Condition: Voltage feedback from the HEGO 2 sensor heater should always equal ground voltage.
- Condition: HEGO 2 low-side feedback < 5.0% Vbat
- MIL: ON during active fault

### Fault Description

This fault will set when the HEGO heater control feedback signal does not see Vbat when the heater is switched off.

This may be caused by a bad heater element in the HEGO sensor, a break in the wire harness on the heater supply or control circuits, or fault within the ECM.

## DTC 31 – EGOH1 Open / Ground Short

Step	Action	Value(s)	Yes	No
1	Did you perform the On-Board (OBD) System Check?	-	Go to Step (2)	Go to OBD System Check Section
2	Key ON, Engine OFF Disconnect the harness from the HEGO sensor. With a DMM, measure the heater resistance within the sensor (C & D). Normal resistance is approximately 2.5 ohms.	Is the resistance >50 ohms?	Go to Step (3)	Go to Step (4)
3	HEGO heater element is bad Replace HEGO sensor			-
4	Disconnect the harness from the ECM With DMM, check for continuity in the harness on the heater control signal (Test between Pin D on the HEGO sensor connector and Pin 49 on the ECM connector).	Does continuity exist (is resistance <50 ohms?)	Go to Step (5)	Go to Step (6)
5	Replace ECM			
6	Repair/Replace circuit in harness			

## DTC 32 – EGOH1 Short to Power

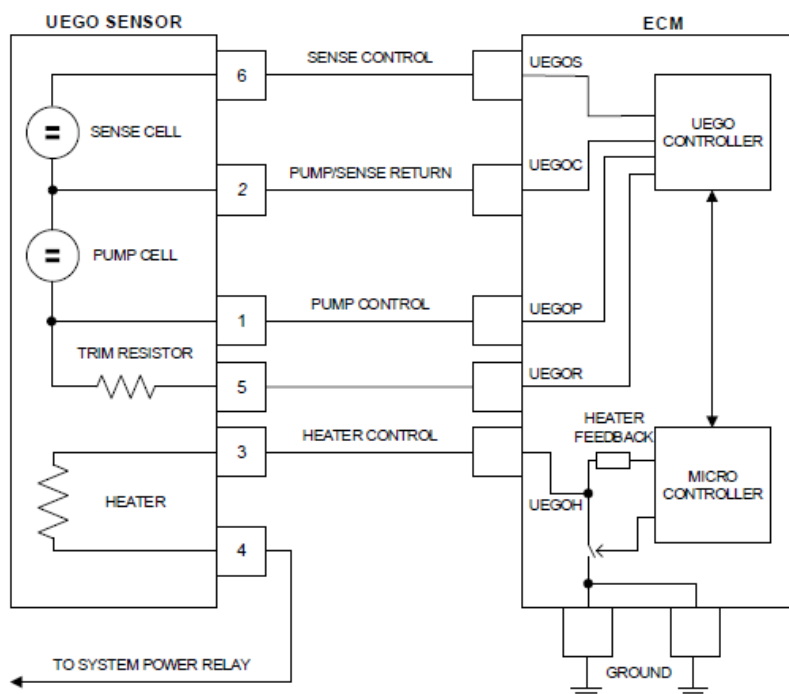

### Conditions for Setting the DTC

- Check Condition: Key-On, Engine Cranking or Running
- Fault Condition: Voltage feedback from the UEGO sensor heater is always equal to the battery or supply voltage (short to V<sub>battery</sub>).
- MIL: ON during active fault

### Fault Description

A UEGO sensor measures the exhaust content across a wide-range of air-fuel ratios with a linear output proportional to lambda/equivalence ratio/air-fuel ratio. The sensor is heated with an internal resistive element that is supplied by the battery voltage and switched on/off by the ECM. The ECM will pull the heater control signal to ground when turning on the heater. The ECM monitors the heater control signal for a short to ground. If the control signal is not equal to V<sub>battery</sub> when the heater is turned off then the circuit is not functioning properly.

This fault will set when the UEGO heater control signal does not achieve zero volts when the heater is switched on. This may be caused by an internal fault within the ECM.

## DTC 32 – EGOH1 Short to Power

Step	Action	Value(s)	Yes	No
1	Did you perform the On-Board (OBD) System Check?	-	Go to Step (2)	Go to OBD System Check Section
2	Key ON, Engine OFF Disconnect the harness from the UEGO sensor. With a DMM, measure the heater resistance. (For the Bosch sensor, measure the resistance between the white and grey lines connected to pins 3 and 4.) Normal resistance is approximately 2.5 ohms.	Is the resistance <0.5 ohms?	Go to Step (3)	Go to Step (4)
3	UEGO heater element is bad Replace UEGO sensor			
4	Disconnect the harness from the ECM Check the heater control signal (Test between Pin 3 of the UEGO sensor and Pin 75 on the ECM) for a short to Vbattery. NOTE: Perform this test using a DMM and check one pin at a time to the positive battery terminal.	Is the circuit shorted?	Go to Step (5)	Go to Step (6)
5	Repair short to Vbattery in harness			
6	Replace ECM			

## DTC 51 - EGOH2 Open / Ground Short

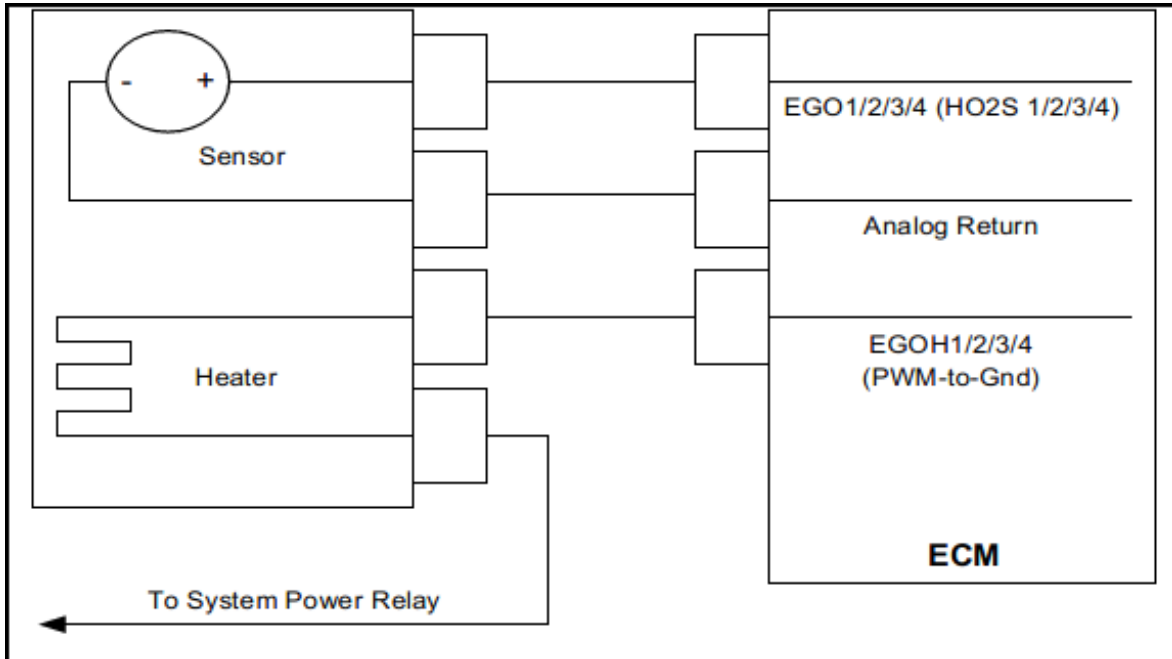

### Conditions for Setting the DTC

- Check Condition: Key-On, Engine Cranking or Running
- Fault Condition: Voltage feedback from the HEGO 2 sensor heater should always equal ground voltage.
- Condition: HEGO 2 low-side feedback < 5.0% Vbat
- MIL: ON during active fault

### Fault Description

This fault will set when the HEGO heater control feedback signal does not see Vbat when the heater is switched off.

This may be caused by a bad heater element in the HEGO sensor, a break in the wire harness on the heater supply or control circuits, or fault within the ECM.

## DTC 51 - EGOH2 Open / Ground Short

Step	Action	Value(s)	Yes	No
1	Did you perform the On-Board (OBD) System Check?	-	Go to Step (2)	Go to OBD System Check Section
2	Key ON, Engine OFF Disconnect the harness from the HEGO sensor. With a DMM, measure the heater resistance within the sensor (C & D). Normal resistance is approximately 2.5 ohms.	Is the resistance >50 ohms?	Go to Step (3)	Go to Step (4)
3	HEGO heater element is bad Replace HEGO sensor			-
4	Disconnect the harness from the ECM With DMM, check for continuity in the harness on the heater control signal (Test between Pin D on the HEGO sensor connector and Pin 50 on the ECM connector).	Does continuity exist (is resistance <50 ohms?)	Go to Step (5)	Go to Step (6)
5	Replace ECM			
6	Repair/Replace circuit in harness			



## DTC 52 - EGOH2 Short to Power

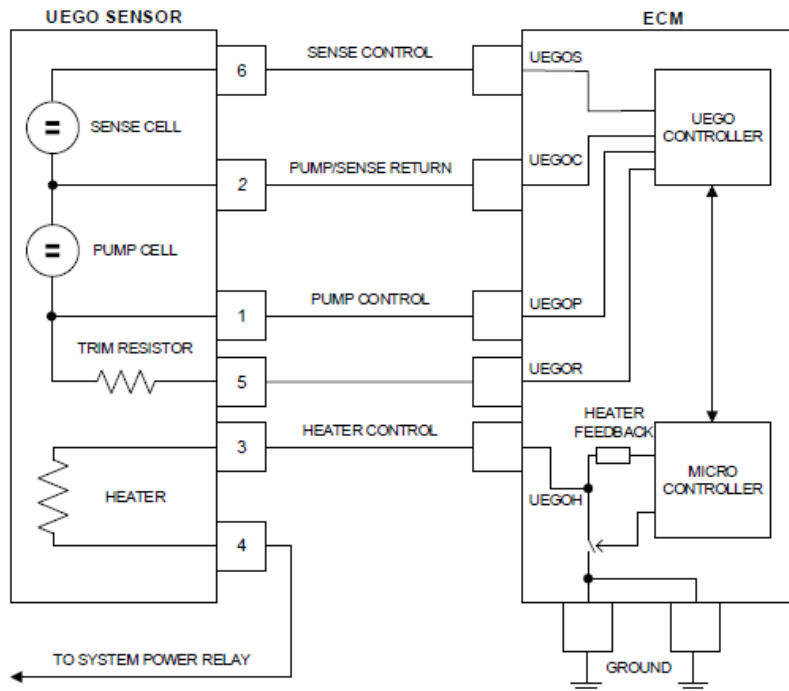

### Conditions for Setting the DTC

- Check Condition: Key-On, Engine Cranking or Running
- Fault Condition: Voltage feedback from the UEGO sensor heater is always equal to the battery or supply voltage (short to Vbattery.)
- MIL: ON during active fault

### Fault Description

A UEGO sensor measures the exhaust content across a wide-range of air-fuel ratios with a linear output proportional to lambda/equivalence ratio/air-fuel ratio. The sensor is heated with an internal resistive element that is supplied by the battery voltage and switched on/off by the ECM. The ECM will pull the heater control signal to ground when turning on the heater. The ECM monitors the heater control signal for a short to ground. If the control signal is not equal to Vbattery when the heater is turned off, then the circuit is not functioning properly.

This fault will set when the UEGO heater control signal does not achieve zero volts when the heater is switched on. This may be caused by an internal fault within the ECM.

## DTC 52 - EGOH2 Short to Power

Step	Action	Value(s)	Yes	No
1	Did you perform the On-Board (OBD) System Check?	-	Go to Step (2)	Go to OBD System Check Section
2	Key ON, Engine OFF Disconnect the harness from the UEGO sensor. With a DMM, measure the heater resistance. (For the Bosch sensor, measure the resistance between the white and grey lines connected to pins 3 and 4.) Normal resistance is approximately 2.5 ohms.	Is the resistance <0.5 ohms?	Go to Step (3)	Go to Step (4)
3	UEGO heater element is bad Replace UEGO sensor			
4	Disconnect the harness from the ECM Check the heater control signal (Test between Pin 3 of the UEGO sensor and Pin 75 on the ECM) for a short to Vbattery. NOTE: Perform this test using a DMM and check one pin at a time to the positive battery terminal.	Is the circuit shorted?	Go to Step (5)	Go to Step (6)
5	Repair short to Vbattery in harness			
6	Replace ECM			

## DTC 57 EGOH4 Open/Ground Short (SPN 3271:FMI 4)

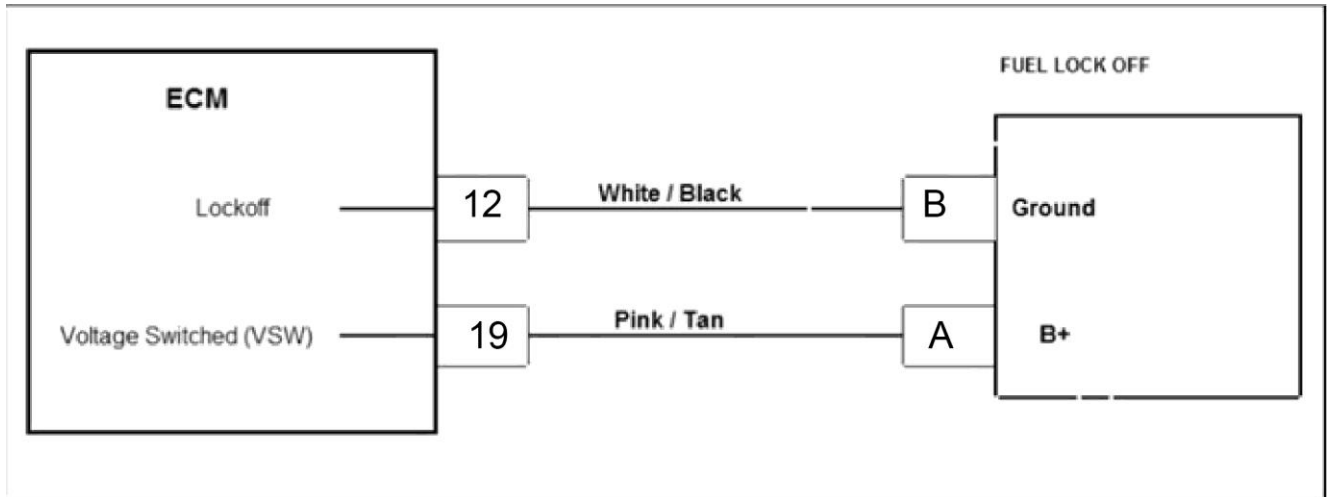

### Conditions for Setting the DTC

- LPG lock-off valve
- Check Condition-Engine Cranking
- Low side voltage is less than 5.0v
- MIL-ON

### Circuit Description

The LPG lock off valve is supplied battery power through the VSW circuit. The ECM then provides a path to ground to open the valve. This fault will set if the ECM detects a low voltage on the low side when the lock-off valve “off”.

The DTC name indicates “EGOH” which is related to EGO Heater circuit, however the circuit is used to supply the lockoff ground in certain applications.

Step	Action	Value(s)	Yes	No
1	Did you perform the On-Board (OBD) System Check?	-	Go to Step (2)	See "OBD SystemCheck"
2	<ul style="list-style-type: none"> <li>Disconnect the fuel lock-off valve solenoid connector</li> <li>Using a DVOM check for power across terminals A and B while cranking the engine.</li> </ul> Is system voltage present?	System Voltage	Go to Step (3)	Go to Step (4)
3	<ul style="list-style-type: none"> <li>Key off</li> <li>Using a DVOM check for power across terminals A and B.</li> </ul> Is system voltage still present?	0v	Go to Step (5)	Go to Step (4)
4	<ul style="list-style-type: none"> <li>Key OFF</li> <li>Disconnect the ECM connector</li> <li>Disconnect the fuel lock-off valve connector</li> <li>Using a DVOM check for continuity between ECM pin 12 and lock-off valve terminal B.</li> </ul> Do you have continuity?		Go to Step (5)	Repair the open circuit. See " <b>Engine Wire Harness Repair</b> "
5	<ul style="list-style-type: none"> <li>Key OFF</li> <li>Disconnect the ECM connector</li> <li>Disconnect the fuel lock-off valve connector</li> <li>Using a DVOM check for continuity between ECM pin 12 and engine ground</li> </ul> Do you have continuity?		Repair the short circuit. See " <b>Engine Wire Harness Repair</b> "	Go to Step (6)
6	<ul style="list-style-type: none"> <li>Replace the fuel lock-off valve</li> </ul> Is the issue resolved?			Go to Step (7)

Step	Action	Value(s)	Yes	No
7	<ul style="list-style-type: none"> <li>Inspect the ECM wire harness and connector for damage corrosion or contamination</li> </ul> <p>Did you find a problem?</p>		Correct the problem as required. See wire harness repair.	Go to Step (8)
8	<ul style="list-style-type: none"> <li>Replace the ECM</li> </ul> <p>Is replacement complete?</p>		Go to Step (9)	
9	<ul style="list-style-type: none"> <li>Remove all test equipment except the DST.</li> <li>Connect any disconnected components, fuses, etc.</li> <li>Using the DST clear DTC information from the ECM.</li> <li>Turn the ignition OFF and wait 30 seconds.</li> <li>Start the engine and operate the vehicle to full operating temperature</li> <li>Observe the MIL</li> <li>Observe the MIL</li> <li>Observe engine performance</li> <li>After operating the engine within the test parameters of DTC-57 check for any stored codes.</li> </ul> <p>Does the engine operate normally with no stored codes?</p>		System OK	<b>Go to "OBD System Check"</b>

## DTC 87 – Fuel Pressure Low (SPN 94:FMI 1)

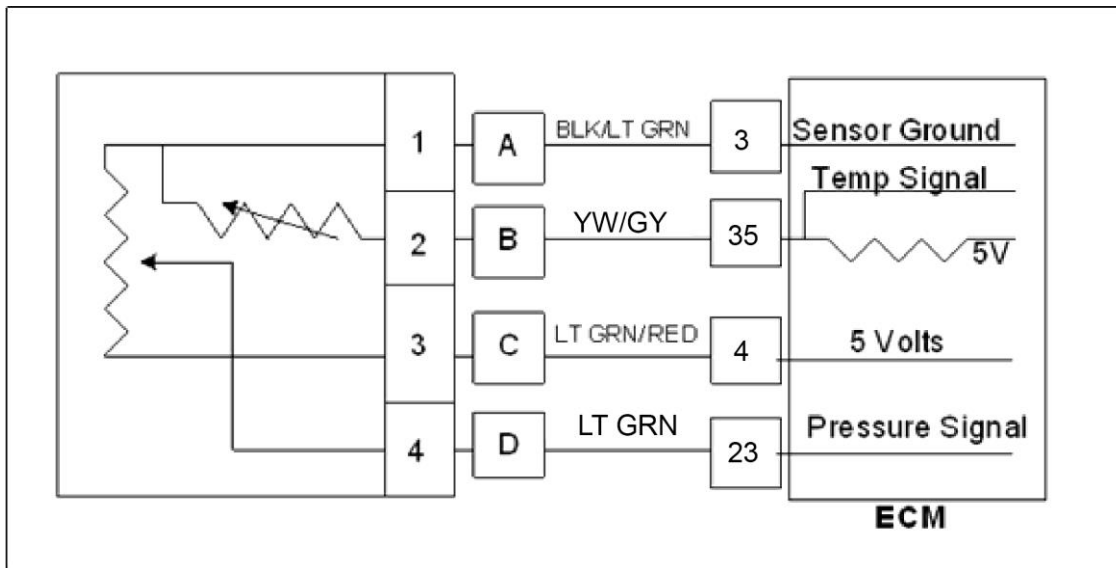

### Conditions for setting the DTC

- Fuel Pressure is less than 55 psia
- Fault must be active for 3.0 seconds to activate DTC
- MIL light on during fault
- Forced idle is enabled

### Circuit Description

This engine is equipped with a fuel injector rail that does not have a pressure regulator or a return circuit to the fuel tank. Fuel pressure for this engine is regulated by the engine's ECM. The ECM receives fuel pressure and temperature feedback from the gasoline fuel sensor manifold and uses this information to control the ground side of the fuel pump. Fuel pressure is regulated by the ECM pulse width modulating (PWM) the fuel pump. The fuel pressure and temperature sensor manifold have a return or "bleed" circuit that connects back to the equipment fuel tank. This circuit is used to bleed off any vapor that develops in the line and returns a small amount of fuel to the tank. The fuel comes from the fuel tank and passes through the fuel pump. Fuel exits the fuel pump, passes through the filter and then enters the fuel pressure and temperature manifold assembly. Fuel flows through the feed circuit and is delivered to the fuel injector rail. Fuel that enters the bleed circuits through the bypass valve in the manifold is returned to the fuel tank.

This DTC can be caused by fuel vapor lock conditions. Inspect the routing of the fuel lines and position of the fuel pressure and return block to ensure the system is routed/mounted away from hot exhaust or other radiant heat sources.

Step	Action	Value(s)	Yes	No
1	Did you perform the On-Board (OBD) System Check?	-	Go to Step (2)	Go to OBD System Check Section
2	<ul style="list-style-type: none"> <li>Key On</li> <li>DST (Diagnostic Scan Tool) connected.</li> </ul> <p>On the FAULTS page, check the value for fuel pressure</p> <p>Does the DST display 55 psia or less?</p>	55 psia or less?	Go to Step (3)	Intermittent problem. Go to intermittent section
3	<ul style="list-style-type: none"> <li>Check the fuel pressure using a manual pressure gauge.</li> </ul> <p>Does the manual pump gauge display 55 psi or less?</p>	55 psia or less?	Go to Step (4)	Go to Step (5)
4	<ul style="list-style-type: none"> <li>Check for an open in the fuel pump ground circuit (OEM supplied)</li> </ul> <p>Is there an open in the ground circuit?</p>		Repair the open circuit	Go to Step (6)
5	<ul style="list-style-type: none"> <li>Jumper pins C and D at the fuel pressure sensor connector</li> <li>Monitor the FRP_Raw volts on the VOLTAGE page.</li> </ul> <p>Does FRP_Raw display 5 volts?</p>	5 volts	Replace the Fuel pressure Sensor	Repair the wiring between the fuel pump pressure sensor and the ECM
6	<ul style="list-style-type: none"> <li>Check the OEM fuel hoses for proper installation and routing</li> <li>Check the OEM fuel hoses for blockages</li> </ul> <p>Were the OEM fuel hoses improperly installed or have a blockage</p>		Repair the OEM fuel hose issue	Replace ECM

## DTC 88 – Fuel Pressure High (SPN 94:FMI 0)

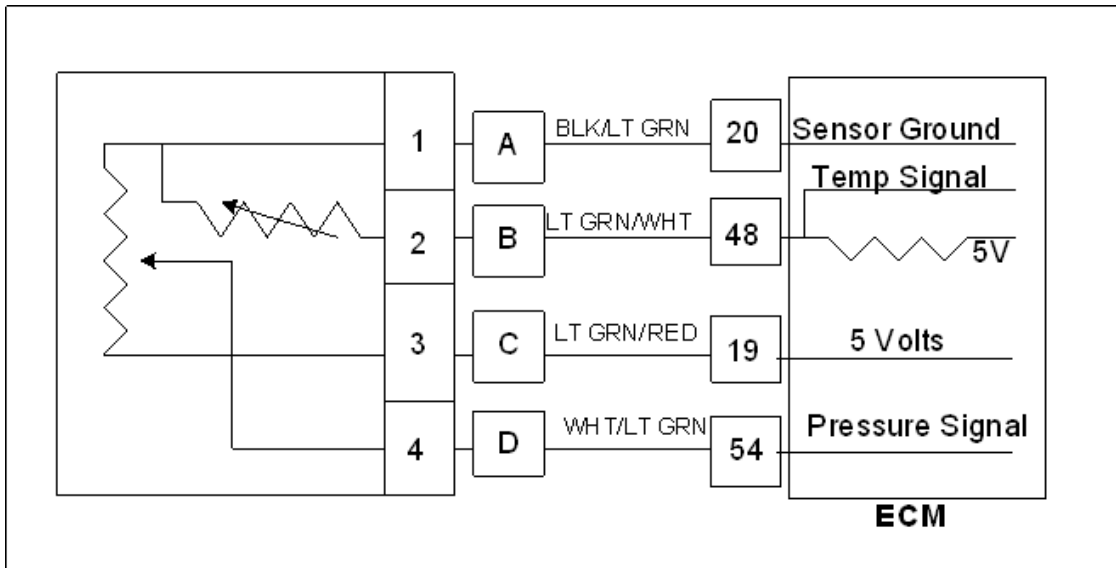

### Conditions for setting the DTC

- Fuel Pressure is greater than 90 psia
- Fault must be active for 3.0 seconds to activate DTC
- MIL light on during fault
- Forced idle is enabled

### Circuit Description

This engine is equipped with a fuel injector rail that does not have a pressure regulator or a return circuit to the fuel tank. Fuel pressure for this engine is regulated by the engine's ECM. The ECM receives fuel pressure and temperature feedback from the gasoline fuel sensor manifold and uses this information to control the ground side of the fuel pump. Fuel pressure is regulated by the ECM pulse width modulating (PWM) the fuel pump. The fuel pressure and temperature sensor manifold has a return or "bleed" circuit that connects back to the equipment fuel tank. This circuit is used to bleed off any vapor that develops in the line and returns a small amount of fuel to the tank. The fuel comes from the fuel tank and passes through the fuel pump. Fuel exits the fuel pump, passes through the filter and then enters the fuel pressure and temperature manifold assembly. Fuel flows through the feed circuit and is delivered to the fuel injector rail. Fuel that enters the bleed circuits through the by-pass valve in the manifold is returned to the fuel tank.



STEP	Action	Value(s)	Yes	No
1	Did you perform the On-Board (OBD) System Check?	-	Go to Step (2)	Go to OBD System Check Section
2	<ul style="list-style-type: none"> <li>Key On</li> <li>DST (Diagnostic Scan Tool) connected</li> </ul> On the FAULTS page, check the value for fuel rail pressure Does the DST display 90 psia or greater?	90 psia or greater	Go to Step (3)	Intermittent problem. Go to intermittent section
3	<ul style="list-style-type: none"> <li>Check the fuel pressure using a manual fuel pressure gauge</li> </ul> Does the manual gauge display 90 psi or greater?	90 psia or greater	Go to Step (4)	Go to step (5)
4	<ul style="list-style-type: none"> <li>Check for a short to ground in the fuel pump ground circuit (OEM supplied)</li> </ul> Is the ground circuit shorted to a ground?		Repair the short to ground	Go to step (6)
5	<ul style="list-style-type: none"> <li>Jumper pins C and D at the fuel pressure sensor connector</li> <li>Monitor the FRP_Raw volts on the VOLTAGE page.</li> </ul> Does FRP_Raw display 5 volts?	5 volts	Replace the Fuel pressure Sensor	Repair the wiring between the fuel pump pressure sensor and the ECM
6	<ul style="list-style-type: none"> <li>Check the OEM fuel hoses for proper installation and routing</li> <li>Check the OEM fuel hoses for blockages</li> </ul> Were the OEM fuel hoses improperly installed or have a blockage?		Repair the OEM fuel hose issue	Replace ECM

## **DTC 91 – Gasoline Fuel Pressure Sensor Low Voltage (SPN 94:FMI 4)**

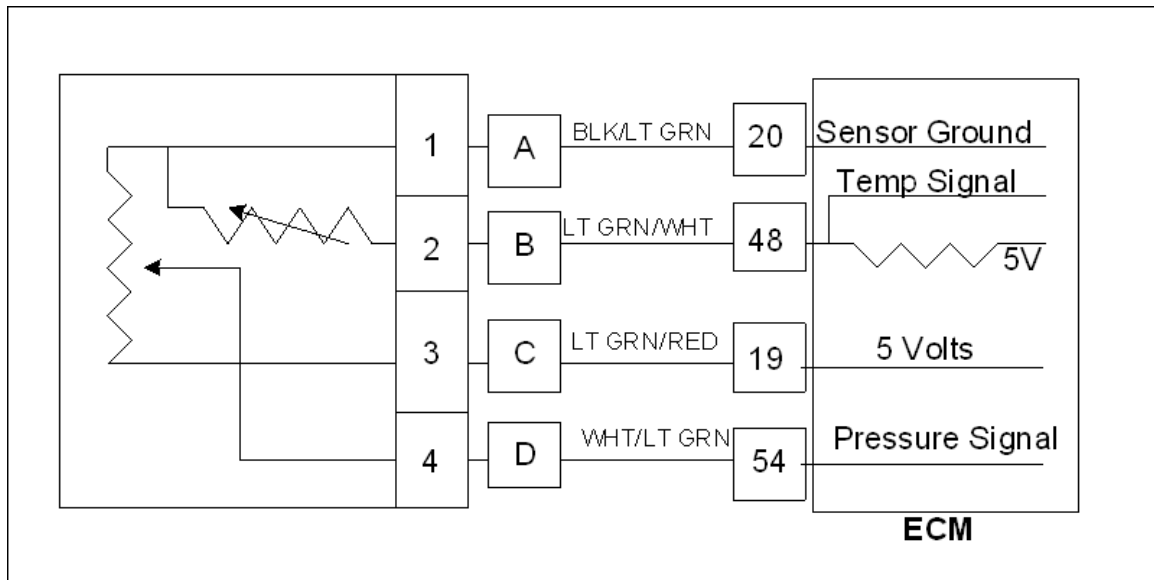

### **Conditions for Setting the DTC**

- Gasoline fuel temperature sensor voltage
- Fuel pressure sensor voltage less than 0.2v for greater than 1 second
- MIL-On for active fault and for 2 seconds after active fault
- Adaptive Learn is disabled during fault condition
- Forced idle is enabled

### **Circuit Description**

Note: The fuel pressure and temperature sensor is wired via Equipment Manufacturer supplied harness jumper. The terminals A, B, C, D & 19, 20, 48, 54 are engine wiring harness terminals at the fuel sensor interface connector C002 and the ECM header connector C001. You may need to consult additional wiring information supplied by the OEM. The gasoline fuel pressure sensor voltage is read at less than 0.2v. This indicates a low voltage fault from the sensor or circuit. This fault can occur when a ground is lost on the black/Lt Green circuit.

## **DTC 92 – Gasoline Fuel Pressure Sensor High Voltage (SPN 94:FMI 3)**

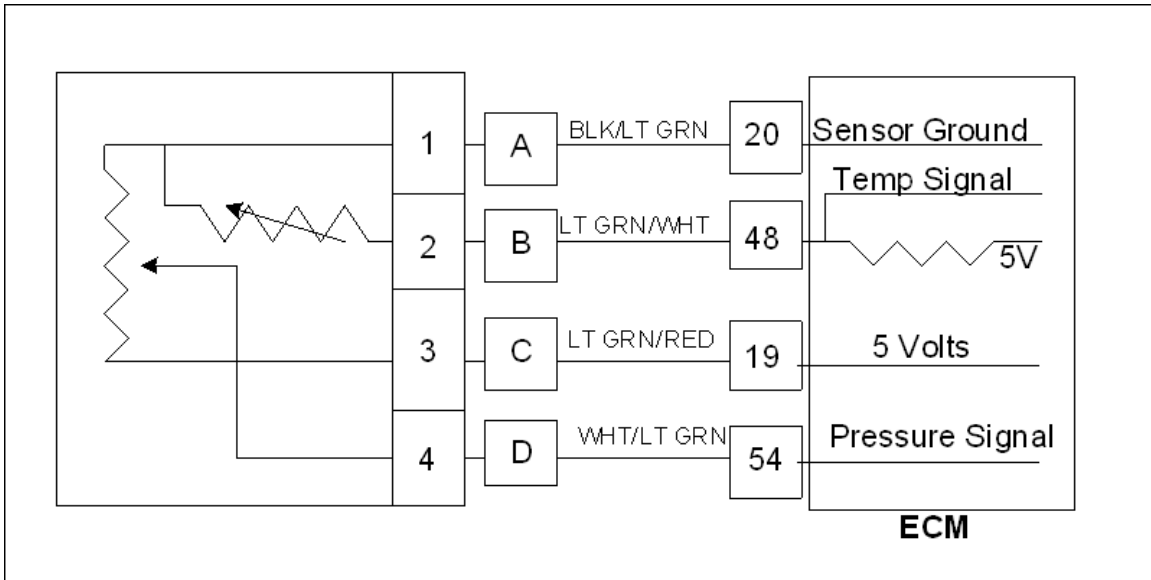

### **Conditions for Setting the DTC**

- Gasoline fuel temperature sensor voltage
- Fuel pressure sensor voltage greater than 4.8v for greater than 1 second
- MIL-On for active fault and for 2 seconds after active fault
- Adaptive Learn is disabled during fault condition
- Forced Idle is enabled

### **Circuit Description**

Note: The fuel pressure and temperature sensor is wired via Equipment Manufacturer supplied harness jumper. The terminals A, B, C, D & 19, 20, 48, 54 are engine wiring harness terminals at the fuel sensor interface connector C002 and the ECM header connector C001. You may need to consult additional wiring information supplied by the OEM. The gasoline fuel pressure sensor voltage is reading greater than 4.8v. This indicates a high voltage fault from the sensor or circuit.

## **DTC 107 – MAP Low Voltage (SPN 106:FMI 4)**

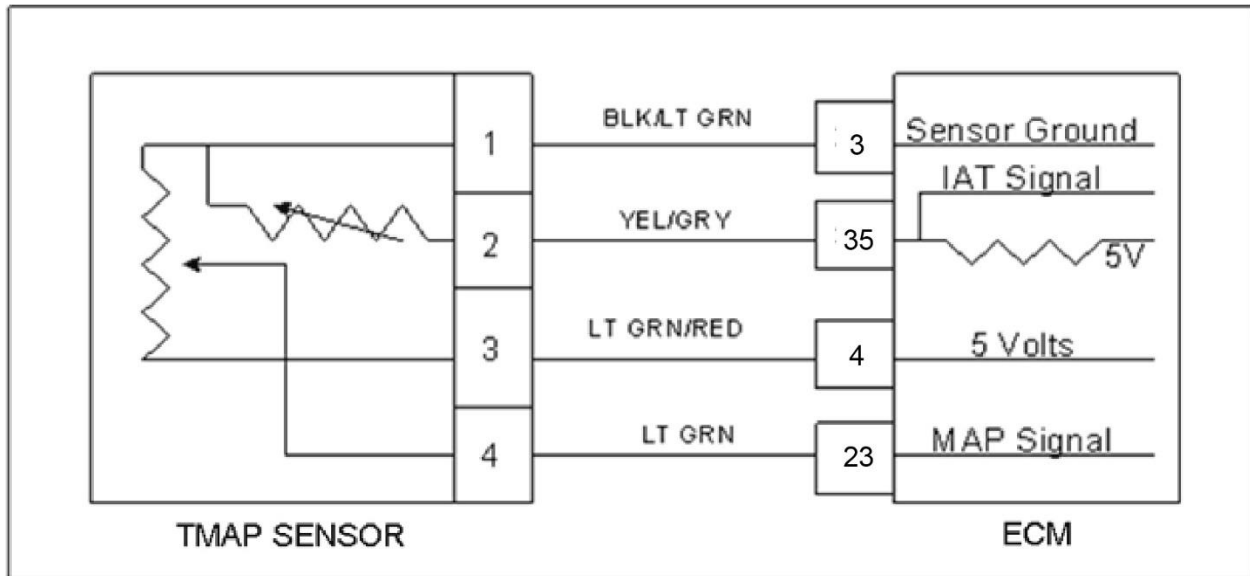

### **Conditions for Setting the DTC**

- Manifold Absolute Pressure Sensor
- Check Condition-Engine cranking or running
- Fault Condition-MAP voltage less than 0.050 with throttle position greater than 2.0% and engine RPM less than 3000.
- MIL-ON
- Adaptive-Disabled
- Fueling is based on RPM and TPS Limp-Home Condition during this fault.

### **Circuit Description**

The Manifold Absolute Pressure sensor is a pressure transducer connected to the intake manifold. It is used to measure the pressure of air in the manifold prior to induction. The pressure reading is used in conjunction with other inputs to estimate the airflow rate to the engine, which determines the fuel flow rate. This fault will set if the MAP voltage is less than 0.050 with TPS greater than 2% and engine RPM is less than 3000. The Adaptive Learn will be disabled for the remainder of the key on cycle and the MIL command is on.

Step	Action	Value(s)	Yes	No
1	Did you perform the On-Board (OBD) System Check?	-	Go to Step (2)	Go to OBD System Check Section
2	<ul style="list-style-type: none"> <li>Key ON, Engine running.</li> <li>DSC (Diagnostic Scan Tool) connected in System Data Mode</li> </ul> Does DST display MAP voltage of 0.050 or less with the engine running below 3000 rpm and TPS above 2.0 %?		Go to Step (3)	Intermittent problem Go to Intermittent section
3	<ul style="list-style-type: none"> <li>Key OFF</li> <li>Disconnect the MAP sensor connector C006 from the wiring harness</li> <li>Jump the 5-volt reference pin 3 and MAP signal circuit pin 4 together</li> <li>Key ON</li> </ul> Does the DST display MAP voltage of 4.5volts or greater?		Go to Step (4)	Go to Step (8)
4	<ul style="list-style-type: none"> <li>Inspect MAP connector and pins for corrosion, contamination or mechanical damage</li> </ul> Any problems found?		Repair the circuit as necessary. Refer to Wiring Repairs in Engine Electrical.	Go to Step (5)
5	<ul style="list-style-type: none"> <li>Key OFF</li> <li>Disconnect ECM connector C001</li> <li>Check for continuity between MAP sensor connector signal pin 4 and ECM MAP signal pin 23.</li> </ul> Do you have continuity between them?		Go to Step (6)	Repair the circuit as necessary. Refer to Wiring Repairs in Engine Electrical.
6	<ul style="list-style-type: none"> <li>Check for continuity between MAP sensor connector 5-volt supply signal pin 3 and ECM 5-volt supply pin 4</li> </ul> Do you have continuity between them?		Go to Step (7)	Repair the circuit as necessary. Refer to Wiring Repairs in Engine Electrical.
7	<ul style="list-style-type: none"> <li>Check for continuity between MAP sensor connector ground pin 1 and ECM sensor ground pin 3</li> </ul> Do you have continuity between them?		Go to Step (17)	Repair the circuit as necessary. Refer to Wiring Repairs in Engine Electrical.

Step	Action	Value(s)	Yes	No
8	<ul style="list-style-type: none"> <li>Probe MAP connector signal circuit pin 4 with a test light connected to battery voltage.</li> </ul> Does the DST display MAP voltage of 4.0 or greater?		Go to Step (9)	Go to Step (13)
9	<ul style="list-style-type: none"> <li>Key OFF</li> <li>Disconnect ECM connector</li> <li>Check for continuity between MAP sensor connector pin 3 and ECM 5-volt pin 4.</li> </ul> Do you have continuity between them?		Go to Step (10)	Repair the circuit as necessary. Refer to Wiring Repairs in Engine Electrical.
10	<ul style="list-style-type: none"> <li>Check for continuity between MAP sensor connector 5 volt reference pin 3 and engine ground</li> </ul> Do you have continuity?		Repair the circuit as necessary. Refer to Wiring Repairs in Engine Electrical.	Go to Step (11)
11	<ul style="list-style-type: none"> <li>Inspect ECM and MAP wire harness connector and terminals for corrosion, contamination or mechanical damage</li> </ul> Any problems found?		Repair the circuit as necessary. Refer to Wiring Repairs in Engine Electrical.	Go to Step (16)
12	<ul style="list-style-type: none"> <li>Replace ECM. Refer to ECM replacement in the Engine Controls Section.</li> </ul> Is the replacement complete?		Go to Step (17)	-
13	<ul style="list-style-type: none"> <li>Disconnect ECM connector</li> <li>Check for continuity between MAP sensor connector signal circuit pin 4 and ECM signal pin 23.</li> </ul> Do you have continuity between them?		Go to Step (14)	Repair the circuit as necessary. Refer to Wiring Repairs in Engine Electrical.
14	<ul style="list-style-type: none"> <li>Check for continuity between MAP sensor connector signal pin 4 and engine ground</li> </ul> Do you have continuity?		Repair the circuit as necessary. Refer to Wiring Repairs in Engine Electrical.	Go to Step (15)
15	<ul style="list-style-type: none"> <li>Inspect ECM connector and wire harness connector terminals for corrosion, contamination or mechanical damage</li> </ul> Any problems found?		Repair the circuit as necessary. Refer to Wiring Repairs in Engine Electrical.	Go to Step (16)

16	<ul style="list-style-type: none"> <li>• Replace ECM. Refer to ECM replacement in the Engine Controls Section.</li> <li>• Is the replacement complete?</li> </ul>		Go to Step (18)	-
17	<ul style="list-style-type: none"> <li>• Replace MAP sensor</li> <li>• Is the replacement complete?</li> </ul>		Go to Step (18)	-
18	<ul style="list-style-type: none"> <li>• Remove all test equipment except the DST.</li> <li>• Connect any disconnected components, fuses, etc.</li> <li>• Using the DST clear DTC information from the ECM.</li> <li>• Turn the ignition OFF and wait 30 seconds.</li> <li>• Start the engine and operate the vehicle to full operating temperature</li> <li>• Observe the MIL</li> <li>• Observe engine performance and drivability</li> <li>• After operating the engine within the test parameters of DTC-107 check for any stored codes.</li> <li>• Does the engine operate normally with no stored codes?</li> </ul>		System OK	Go to OBD System Check

## DTC 108-MAP High Pressure (SPN 106:FMI 16)

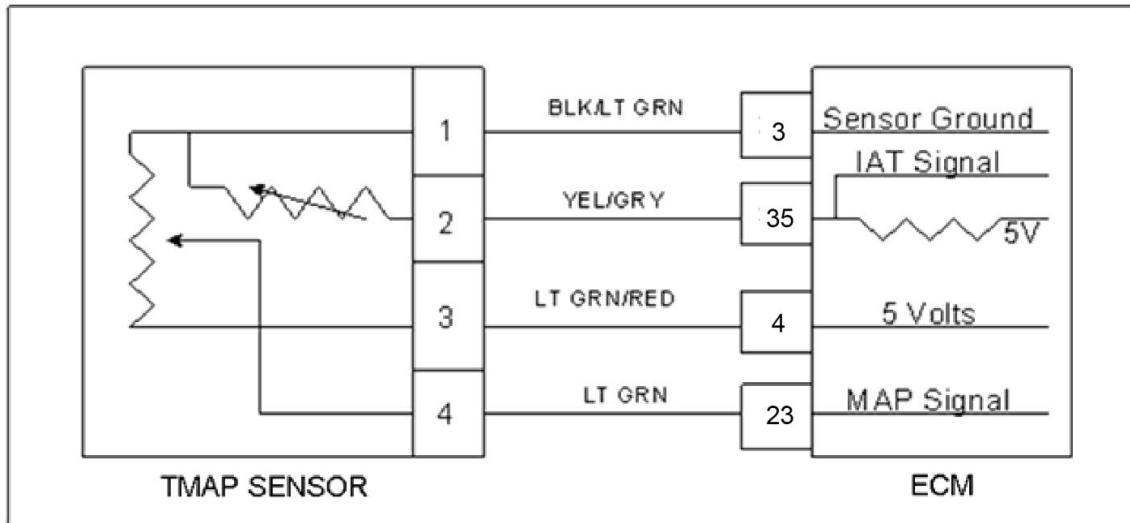

### Conditions for Setting the DTC

- MAP pressure test
- Check condition-engine running
- Fault Condition-MAP greater than 17.00 psia with TPS less than 10% and engine rpm greater than 800.
- MIL-ON
- Adaptive-disabled

### Circuit Description

The MAP (Manifold Absolute Pressure) is estimated from the MAP sensor. The MAP pressure value is used for fuel, airflow, and spark calculations. This fault will set in the event the MAP value is greater than 17.00 psia when the TPS is less than 10% with engine rpm greater than 800.



Step	Action	Value(s)	Yes	No
1	Did you perform the On-Board (OBD) System Check?	-	Go to Step (2)	Go to OBD System Check Section
2	<ul style="list-style-type: none"> <li>Key ON, Engine running at full operating temperature.</li> <li>DST (Diagnostic Scan Tool) connected in System Data Mode</li> </ul> Does DST display MAP pressure of 17 psia or greater with the engine running above 800 rpm with a TPS value less than 10%?		Go to Step (3)	Intermittent problem Go to Intermittent section
3	<ul style="list-style-type: none"> <li>Key OFF</li> <li>Disconnect the MAP sensor connector C006</li> <li>Key ON</li> </ul> Does the DST display MAP pressure less than 0.05 psia?		Go to Step (4)	Go to Step (6)
4	<ul style="list-style-type: none"> <li>Probe MAP connector ground pin 1 with a test light connected to battery voltage.</li> </ul> Does the test light come on?		Go to Step (5)	Go to Step (8)
5	<ul style="list-style-type: none"> <li>Check MAP mechanical vacuum connection for correct mounting or possible damage causing leakage.</li> </ul> Is the MAP sensor mechanical connection, OK?		Go to Step (6)	Go to Step (10)
6	<ul style="list-style-type: none"> <li>Key OFF</li> <li>Disconnect ECM connector and inspect terminals for damage corrosion or contamination.</li> </ul> Is the connection OK?		Go to Step (7)	Repair the circuit as necessary. Referto Wiring Repairs in Engine Electrical.
7	<ul style="list-style-type: none"> <li>Replace MAP sensor. Is the repair complete?</li> </ul>	—	Go to Step (11)	-

Step	Action	Value(s)	Yes	No
8	<ul style="list-style-type: none"> <li>Disconnect ECM connector and check for continuity between MAP connector sensor ground pin 1 and ECM sensor ground pin 20.</li> </ul> Do you have continuity between them?		Go to Step (9)	Repair the circuit as necessary. Refer to Wiring Repairs in Engine Electrical.
9	<ul style="list-style-type: none"> <li>Replace ECM. Refer to ECM replacement in the Engine Controls Section.</li> </ul> Is the replacement complete?		Go to Step (11)	-
10	<ul style="list-style-type: none"> <li>Correct MAP mechanical connection</li> </ul> Has the MAP mechanical connection problem been corrected?		Go to Step (11)	-
11	<ul style="list-style-type: none"> <li>Remove all test equipment except the DST.</li> <li>Connect any disconnected components, fuses, etc.</li> <li>Using the DST clear DTC information from the ECM.</li> <li>Turn the ignition OFF and wait 30 seconds.</li> <li>Start the engine and operate the vehicle to full operating temperature</li> <li>Observe the MIL</li> <li>Observe engine performance and drivability</li> <li>After operating the engine within the test parameters of DTC-108 check for any stored codes.</li> </ul> Does the engine operate normally with no stored codes?		System OK	Go to OBD System Check

## DTC 111-IAT Higher Than Expected 1 (SPN 105:FMI 15)

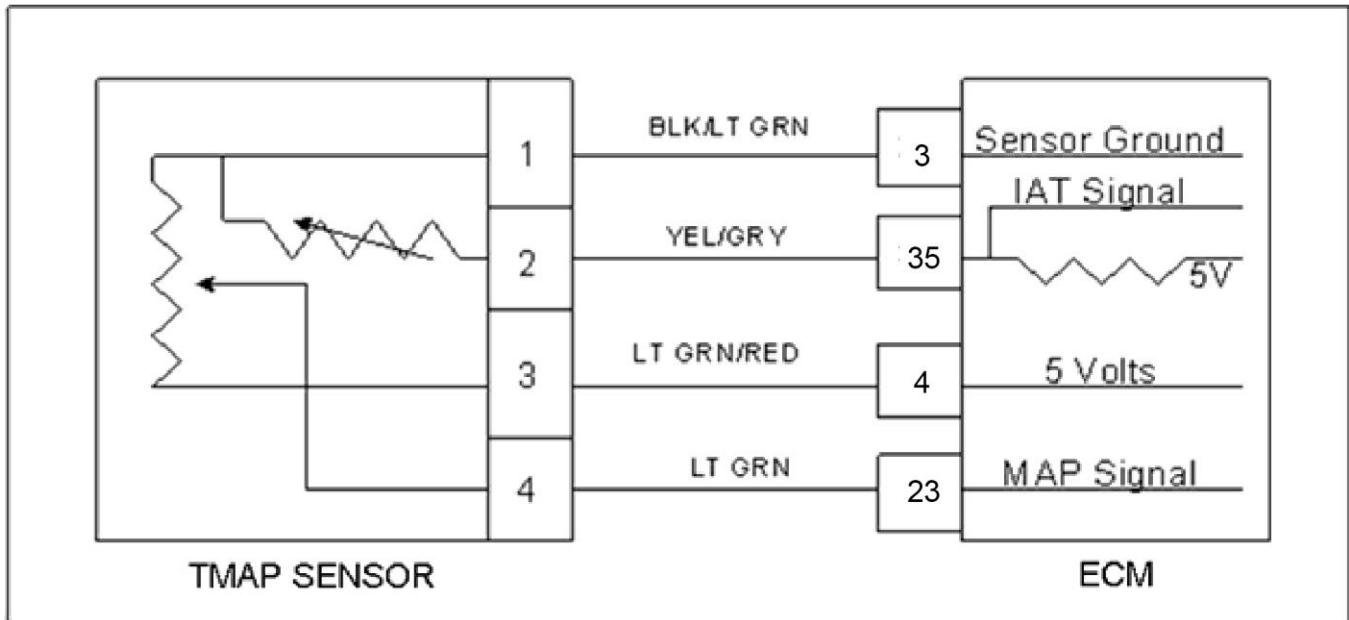

### Conditions for Setting the DTC

- Intake Air Temperature
- Check Condition-Engine Running
- Fault Condition-Intake Air Temperature greater than 200 degrees F. with engine rpm greater than 700
- Condition must be present for a minimum of 60 seconds
- MIL-ON
- Adaptive-Disabled during active fault
- Derate level 1 will occur

### Circuit Description

The TMAP is a combined IAT (Intake Air Temperature) and MAP (Manifold Absolute Pressure) sensor. A temperature sensitive resistor is used in the TMAP located in the air intake manifold of the engine. It is used to monitor incoming air temperature, and the output in conjunction with other sensors is used to determine the airflow to the engine. The ECM provides a voltage divider circuit so that when the air is cool, the signal reads higher voltage, and lower when warm. This fault will set if the Intake Air Temperature is greater than 200 degrees F. with engine speed greater than 700 rpm. The engine will go into a level 1 derate mode to prevent engine damage.

### Diagnostic Aid

This fault will set when inlet air is much hotter than normal. The most common cause of high inlet air temperature is a problem with the inlet air system.

- Ensure that the air inlet is not obstructed, modified, or damaged.
- Inspect the air inlet system for cracks or breaks that may allow unwanted under hood air in to the air inlet system
- If none of the above can be found, follow the diagnostic steps for DTC 112-IAT Low Voltage.

## DTC 112-IAT Low Voltage (SPN 105:FMI 4)

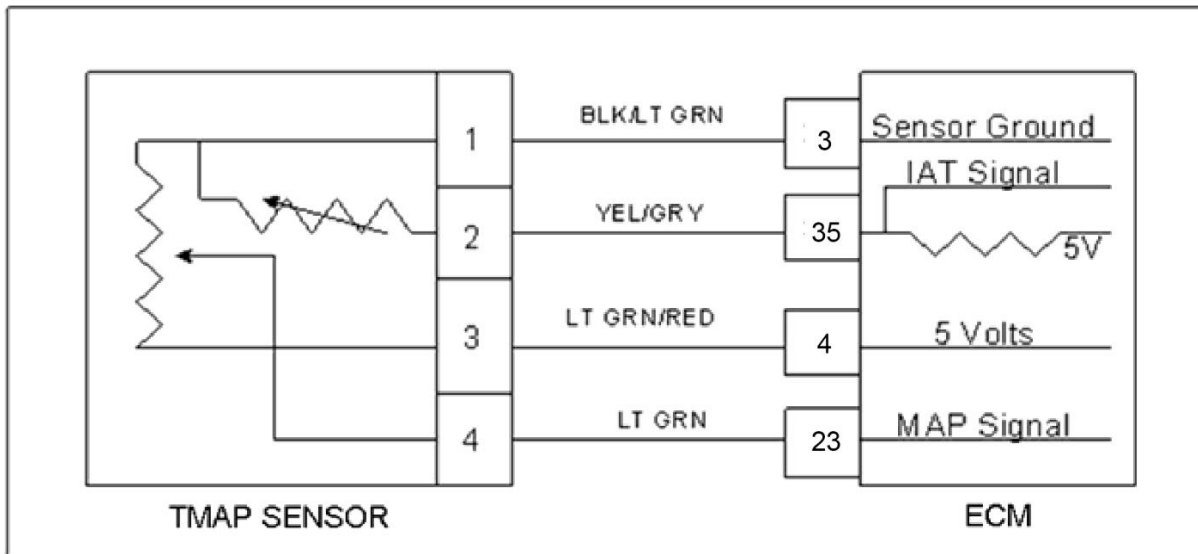

### Conditions for Setting the DTC

- Intake Air Temperature
- Check Condition Engine Cranking or Running
- Fault Condition-IAT Sensor Voltage less than 0.050
- MIL-ON during active fault
- Adaptive-Disabled during active fault

### Circuit Description

The TMAP is a combined IAT (Intake Air Temperature) and MAP (Manifold Absolute Pressure) sensor. A temperature sensitive resistor is used in the TMAP is located in the engine's air intake or intake manifold. It is used to monitor incoming air temperature, and the output in conjunction with other sensors is used to determine the airflow to the engine. The ECM provides a voltage divider circuit so that when the air is cool the signal reads higher voltage, and lower when warm. This fault will set if the signal voltage is less than 0.050 volts for 1 second anytime the engine is cranking or running. The ECM will use the default value for the IAT sensor in the event of this fault.

Step	Action	Value(s)	Yes	No
1	Did you perform the On-Board (OBD) System Check?	–	Go to Step (2)	Go to OBD System Check Section
2	<ul style="list-style-type: none"> <li>• Key ON</li> <li>• DST (Diagnostic Scan Tool) connected in System Data Mode</li> </ul> Does DST display IAT voltage of 0.050 or less?		Go to Step (3)	Intermittent problem Go to Intermittent section
3	<ul style="list-style-type: none"> <li>• Key OFF</li> <li>• Disconnect the TMAP sensor connector.</li> <li>• Key ON</li> </ul> Does the DST display IAT voltage of 4.90 volts or greater?		Go to Step (4)	Go to Step (5)
4	<ul style="list-style-type: none"> <li>• Replace TMAP sensor.</li> </ul> Is the replacement complete?		Go to Step (9)	–
5	<ul style="list-style-type: none"> <li>• Key OFF</li> <li>• Disconnect ECM wire harness connector C001</li> <li>• Check for continuity between TMAP sensor connector ground pin 1 and TMAP sensor connector signal pin 2</li> </ul> Do you have continuity between them?	—	Repair the circuit as necessary. Refer to Wiring Repairs in Engine Electrical.	Go to Step (6)
6	<ul style="list-style-type: none"> <li>• Check for continuity between TMAP sensor connector signal circuit pin 2 and engine ground.</li> </ul> Do you have continuity?	—	Repair the circuit as necessary. Refer to Wiring Repairs in Engine Electrical.	Go to Step (7)
7	<ul style="list-style-type: none"> <li>• Replace ECM. Refer to ECM replacement in the Engine Controls Section.</li> </ul> Is the replacement complete?	–	Go to Step (8)	–
8	<ul style="list-style-type: none"> <li>• Remove all test equipment except the DST.</li> <li>• Connect any disconnected components, fuses, etc.</li> <li>• Using the DST clear DTC information from the ECM.</li> <li>• Turn the ignition OFF and wait 30 seconds.</li> <li>• Start the engine and operate the vehicle to full operating temperature</li> <li>• Observe the MIL</li> <li>• Observe engine performance and drivability</li> <li>• After operating the engine within the test parameters of DTC-112 check for any stored codes.</li> </ul> Does the engine operate normally with no stored codes?		System OK	Go to OBD System Check

## DTC 113-IAT High Voltage (SPN 105:FMI 3)

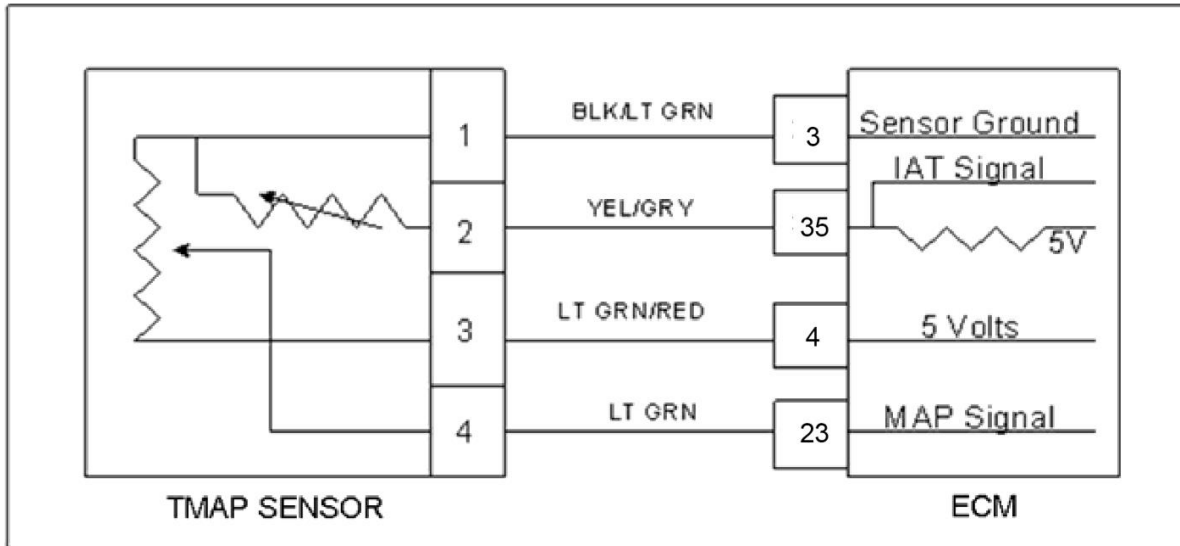

### Conditions for Setting the DTC

- Intake Air Temperature
- Check Condition-Engine Running
- Fault Condition-IAT Sensor Voltage greater than 4.950 volts
- MIL-ON during active fault
- Adaptive-Disabled during active fault

### Circuit Description

The TMAP is a combined IAT (Intake Air Temperature) and MAP (Manifold Absolute Pressure) sensor. A temperature sensitive resistor is used in the TMAP is located in the engine's air intake or intake manifold. It is used to monitor incoming air temperature, and the output in conjunction with other sensors is used to determine the airflow to the engine. The ECM provides a voltage divider circuit so that when the air is cool, the signal reads higher voltage, and lower when warm. This fault will set if the signal voltage is greater than 4.950 volts for 1 second or longer. The ECM will use a default value for the IAT sensor in the event of this fault.

Step	Action	Value(s)	Yes	No
1	Did you perform the On-Board (OBD) System Check?	-	Go to Step (2)	Go to OBD System Check Section
2	<ul style="list-style-type: none"> <li>Key ON</li> <li>DST (Diagnostic Scan Tool) connected in System Data Mode</li> </ul> Does DST display IAT voltage of 4.950 or greater?		Go to Step (3)	Intermittent problem Go to Intermittent section
3	<ul style="list-style-type: none"> <li>Key OFF</li> <li>Disconnect the TMAP sensor connector C006 and jump pins 1 and 2 together</li> <li>Key ON</li> </ul> Does the DST display IAT voltage of 0.1 volts or less?		Go to Step (9)	Go to Step (4)
4	<ul style="list-style-type: none"> <li>Key OFF</li> <li>Jump TMAP sensor connector signal pin 2 to engine ground</li> <li>Key ON</li> </ul> Does DST display IAT voltage of 0.1 volts or less?		Go to Step (7)	Go to Step (6)
5	<ul style="list-style-type: none"> <li>Replace TMAP sensor.</li> </ul> Is the replacement complete?		Go to Step (11)	-
6	<ul style="list-style-type: none"> <li>Key OFF</li> <li>Disconnect the ECM wire harness connector C001.</li> <li>Check for continuity between TMAP sensor connector signal pin 2 and ECM IAT signal pin 35</li> </ul> Do you have continuity between them?	—	Go to Step (10)	Repair the circuit as necessary. Refer to Wiring Repairs in Engine Electrical.
7	<ul style="list-style-type: none"> <li>Check for continuity between TMAP sensor connector ground circuit pin 1 and ECM sensor ground circuit pin 3</li> </ul> Do you have continuity between them?	—	Go to Step (10)	Repair the circuit as necessary. Refer to Wiring Repairs in Engine Electrical.

Step	Action	Value(s)	Yes	No
8	<ul style="list-style-type: none"> <li>Replace the ECM.</li> </ul> Is the replacement complete?	–	Go to Step (11)	–
9	<ul style="list-style-type: none"> <li>Re-check wire harness and TMAP sensor connector for damage corrosion or contamination</li> </ul> Any problems found?		Repair the circuit as necessary. Referto Wiring Repairs in Engine Electrical	Go to Step (5)
10	<ul style="list-style-type: none"> <li>Re-check wire harness and TMAP sensor connectors for damage corrosion or contamination</li> </ul> Any problems found?		Repair the circuit as necessary. Referto Wiring Repairs in Engine Electrical	Go to Step (8)
11	<ul style="list-style-type: none"> <li>Remove all test equipment except the DST.</li> <li>Connect any disconnected components, fuses, etc.</li> <li>Using the DST clear DTC information fromthe ECM.</li> <li>Turn the ignition OFF and wait 30 seconds.</li> <li>Start the engine and operate the vehicle tofull operating temperature</li> <li>Observe the MIL</li> <li>Observe engine performance and drivability</li> <li>After operating the engine within the test parameters of DTC-113 check for any stored codes.</li> </ul> Does the engine operate normally with no stored codes?		System OK	Go to OBD System Check



## DTC 116-ECT Higher Than Expected 1 (SPN 110:FMI 15)

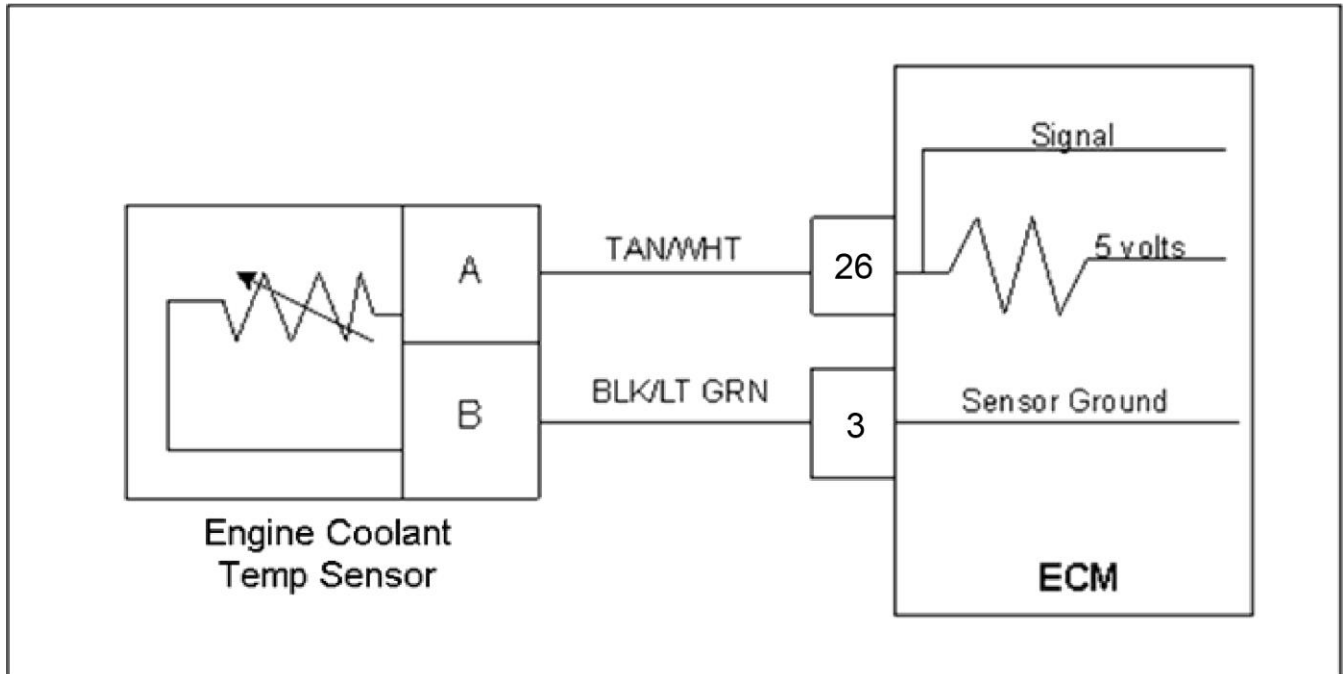

### Conditions for Setting the DTC

- Engine Coolant Temperature
- Check Condition-Engine Running
- Fault Condition-Engine Coolant Temperature reading is higher than diagnostic threshold for greater than 20 seconds
- MIL-On
- Power derate (level 1)
- Adaptive-Disabled during active fault

### Circuit Description

The ECT (Engine Coolant Temperature) sensor is a temperature sensitive resistor located in the engine coolant sensor that is located in the coolant passage. The ECT is used for engine airflow calculation, fuel enrichment, and ignition timing control and to enable certain other temperature dependent operations. This code set is designed to help prevent engine damage from overheating. The ECM provides a voltage divider circuit so when the sensor reading is cool the sensor reads higher voltage, and lower when warm. This fault will set when the coolant exceeds the diagnostic threshold for more than 20 seconds. Power derate level one will be enforced during this fault limiting the maximum throttle position to 50%.

Step	Action	Value(s)	Yes	No
1	Did you perform the On-Board (OBD) System Check?			Go to Step (2)
2	<ul style="list-style-type: none"> <li>Key ON</li> <li>DST (Diagnostic Scan Tool) connected in System Data Mode</li> </ul> Warm engine to normal operating temperature, then run the engine above 1200 rpm for at least 60 seconds  Does DST display ECT temperature of 236 degrees F or greater?			Go to Step (3)
3	Verify with a temperature gauge that the engine coolant is over 236 degrees F.  Does the temperature gauge indicate 236 degrees F. or greater?			Repair cooling system
4	Verify ECT Circuit function. Follow diagnostic test procedure for DTC 217 (ECT Higher than expected 2).			

## DTC 117-ECT/CHT Low Voltage (SPN 110:FMI 4)

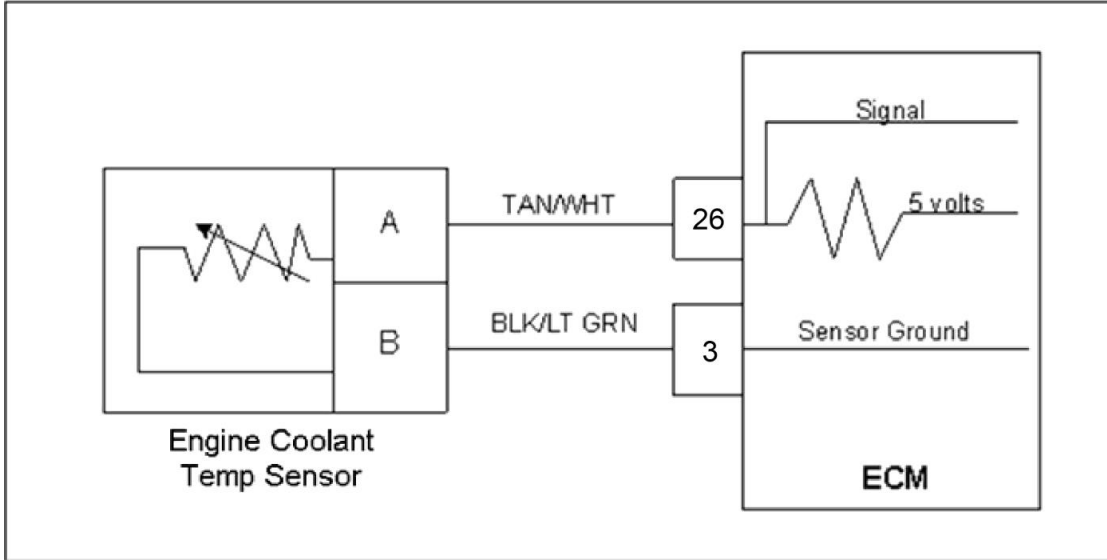

### Conditions for Setting the DTC

- Engine Coolant Temperature
- Check Condition-Engine Running
- Fault Condition-ECT sensor voltage less than 0.050
- MIL-ON during active fault
- Adaptive-Disabled during active fault

### Circuit Description

The ECT (Engine Coolant Temperature) sensor is a temperature sensitive resistor located in the engine coolant passage. It is used for the engine air- flow calculation, cold fuel enrichment and to enable other temperature dependent features. The ECM provides a voltage divider circuit so that when the coolant is cool, the signal reads higher voltage, and lower when warm (see table). This fault will set if the signal voltage is less than 0.050 volts for any period longer than 1 second. The ECM will use a default value for the ECT sensor in the event of this fault.

Temp (deg F)	Ohms +/-10%
242.4	101
231.9	121
211.6	175
201.4	209
181.9	302
163.1	434
144.9	625
127.4	901
102.4	1,556
78.9	2,689
49.9	5,576
23.5	11,562
-5.7	28,770
-21.2	49,715
-30.8	71,589
-40.0	99,301

Step	Action	Value(s)	Yes	No
1	Did you perform the On-Board (OBD) System Check?	–	Go to Step (2)	Go to OBD System Check Section
2	<ul style="list-style-type: none"> <li>Key ON</li> <li>DST (Diagnostic Scan Tool) connected in</li> <li>System Data Mode</li> </ul> Does DST display ECT voltage of 0.050 or less?		Go to Step (3)	Intermittent problem Go to Intermittent section
3	<ul style="list-style-type: none"> <li>Key OFF</li> <li>Disconnect the ECT wire harness connector C007</li> <li>Key ON</li> </ul> Does the DST display ECT voltage of 4.90 volts or greater?		Go to Step (4)	Go to Step (5)
4	<ul style="list-style-type: none"> <li>Replace ECT sensor.</li> </ul> Is the replacement complete?		Go to Step (8)	–
5	<ul style="list-style-type: none"> <li>Key OFF</li> <li>Disconnect ECM wire harness connector C001</li> <li>Check for continuity between ECT sensor connector signal pin A and ECT sensor ground pin B</li> </ul> Do you have continuity between them?	—	Repair the circuit as necessary. Refer to Wiring Repairs in Engine Electrical.	Go to Step (6)
6	<ul style="list-style-type: none"> <li>Check for continuity between ECT sensor connector signal circuit pin A and engine ground.</li> </ul> Do you have continuity?	—	Repair the circuit as necessary. Refer to Wiring Repairs in Engine Electrical.	Go to Step (7)
7	<ul style="list-style-type: none"> <li>Replace ECM. Refer to ECM replacement in the Engine Controls Section.</li> </ul> Is the replacement complete?	–	Go to Step (8)	–
8	<ul style="list-style-type: none"> <li>Remove all test equipment except the DST.</li> <li>Connect any disconnected components, fuses, etc.</li> <li>Using the DST clear DTC information from the ECM.</li> <li>Turn the ignition OFF and wait 30 seconds.</li> <li>Start the engine and operate the vehicle to full operating temperature</li> <li>Observe the MIL</li> <li>Observe engine performance and drivability</li> <li>After operating the engine within the test parameters of DTC-117 check for any stored codes.</li> </ul> Does the engine operate normally with no stored codes?		System OK	Go to OBD System Check

## DTC 118-ECT/CHT High Voltage (SPN 110:FMI 3)

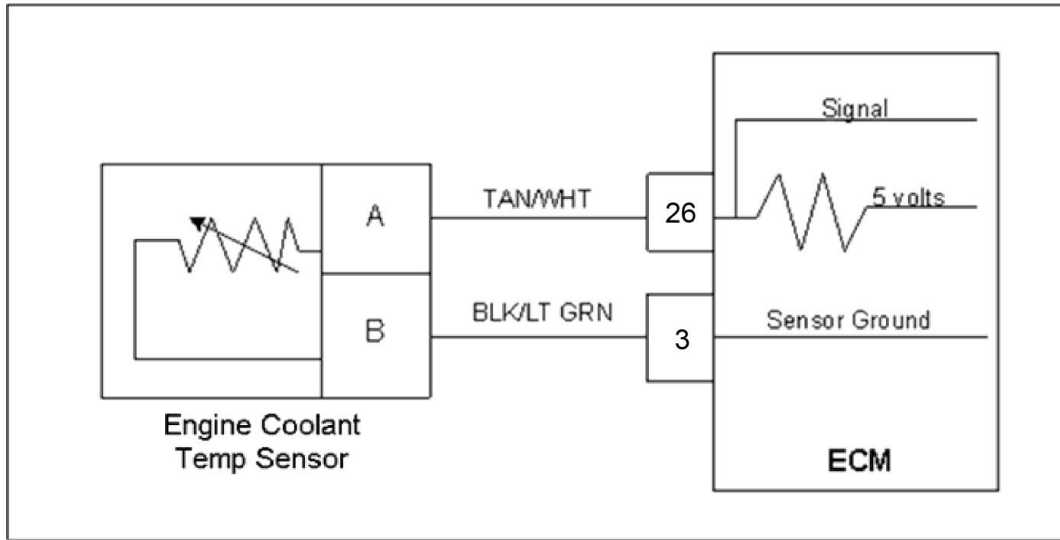

### Conditions for Setting the DTC

- Engine Coolant Temperature
- Check Condition-Engine Running
- Fault Condition-ECT sensor voltage exceeds 4.950 volts
- MIL-ON during active fault
- Adaptive-Disabled

### Circuit Description

The ECT (Engine Coolant Temperature) sensor is a temperature sensitive resistor located in the engine coolant passage. It is used for the engine airflow calculation, cold fuel enrichment and to enable other temperature dependent features. The ECM provides a voltage divider circuit so that when the coolant is cool, the signal reads higher voltage, and lower when warm (see table). This fault will set if the signal voltage is greater than 4.950 volts anytime the engine is running. The ECM will use a default value for the ECT sensor in the event of this fault.

Temp (deg F)	Ohms +/-10%
242.4	101
231.9	121
211.6	175
201.4	209
181.9	302
163.1	434
144.9	625
127.4	901
102.4	1,556
78.9	2,689
49.9	5,576
23.5	11,562
-5.7	28,770
-21.2	49,715
-30.8	71,589
-40.0	99,301

Step	Action	Value(s)	Yes	No
1	Did you perform the On-Board (OBD) System Check?	-	Go to Step (2)	Go to OBD System Check Section
2	<ul style="list-style-type: none"> <li>Key ON</li> <li>DST (Diagnostic Scan Tool) connected in System Data Mode</li> </ul> Does DST display ECT voltage of 4.95 or greater?		Go to Step (3)	Intermittent problem Go to Intermittent section
3	<ul style="list-style-type: none"> <li>Key OFF</li> <li>Disconnect the ECT sensor connector C007 and Jump terminals A and B together</li> <li>Key ON</li> </ul> Does the DST display ECT voltage of 0.05 volts or less?		Go to Step (4)	Go to Step (8)
4	<ul style="list-style-type: none"> <li>Using a DVOM check the resistance between the two terminals of the ECT sensor and compare the resistance reading to the chart</li> </ul> Is the resistance value correct?	See resistance chart vs. temperature in the DTC 118 circuit description	Go to Step (6)	Go to Step (5)
5	<ul style="list-style-type: none"> <li>Replace ECT sensor</li> </ul> Is the replacement complete?		Go to Step (14)	-
6	<ul style="list-style-type: none"> <li>Inspect the ECT wire harness connector terminals A and B for damage, corrosion or contamination</li> </ul> Did you find a problem?		Repair the circuit as necessary. Refer to Wiring Repairs in Engine Electrical.	Go to Step (7)
7	<ul style="list-style-type: none"> <li>Key OFF</li> <li>Disconnect ECM wire harness connector C001</li> <li>Inspect ECM connector pins 3 and 26 for damage corrosion or contamination</li> </ul> Did you find a problem?		Repair the circuit as necessary. Refer to Wiring Repairs in Engine Electrical.	Intermittent problem Go to Intermittent section

Step	Action	Value(s)	Yes	No
8	<ul style="list-style-type: none"> <li>Jump the ECT signal pin A at the ECT connector to engine ground</li> </ul> Does DST display ECT voltage of 0.05 or less?		Go to Step (9)	Go to Step (12)
9	<ul style="list-style-type: none"> <li>Key OFF</li> <li>Disconnect ECM wire harness connector</li> <li>Using a DVOM check for continuity between ECT sensor ground pin B and ECM connector pin 3</li> </ul> Do you have continuity between them?		Go to Step (10)	Repair the circuit as necessary. Refer to Wiring Repairs in Engine Electrical.
10	<ul style="list-style-type: none"> <li>Inspect ECM connector pins 3 and 26 for damage, corrosion or contamination</li> </ul> Did you find a problem?		Repair the circuit as necessary. Refer to Wiring Repairs in Engine Electrical.	Go to Step (11)
11	<ul style="list-style-type: none"> <li>Replace ECM</li> </ul> Is the replacement complete?		Go to Step (14)	-
12	<ul style="list-style-type: none"> <li>Key OFF</li> <li>Disconnect ECM wire harness connector</li> <li>Using a DVOM check for continuity between ECT connector signal pin A and ECM connector terminal 26</li> </ul> Do you have continuity between them?		Go to Step (13)	Repair the circuit as necessary. Refer to Wiring Repairs in Engine Electrical.
13	<ul style="list-style-type: none"> <li>Inspect ECM connector pins 3 and 26 for damage, corrosion or contamination</li> </ul> Did you find a problem?		Repair the circuit as necessary. Refer to Wiring Repairs in Engine Electrical.	Go to Step (11)
14	<ul style="list-style-type: none"> <li>Remove all test equipment except the DST.</li> <li>Connect any disconnected components, fuses, etc.</li> <li>Using the DST clear DTC information from the ECM.</li> <li>Turn the ignition OFF and wait 30 seconds.</li> <li>Start the engine and operate the vehicle to full operating temperature</li> <li>Observe the MIL</li> <li>Observe engine performance and drivability</li> <li>After operating the engine within the test parameters of DTC-118 check for any stored codes.</li> </ul> Does the engine operate normally with no stored codes?		System OK	Go to OBD System Check

## DTC 121-TPS 1 Lower Than TPS 2 (SPN 51:FMI 1)

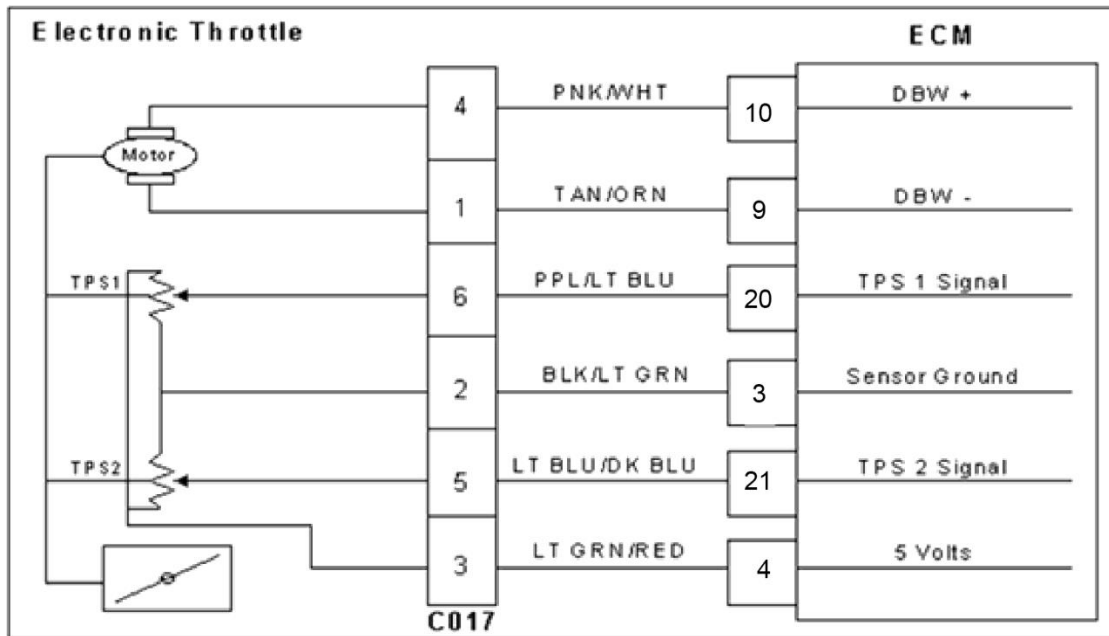

### Conditions for Setting the DTC

- Throttle Position Sensor 1 & 2
- Check Condition-Key ON
- Fault Condition-TPS 1 20% lower than TPS 2
- MIL-ON for remainder of key on cycle
- Engine shutdown

### Circuit description

Dual throttle Position Sensors are used within the throttle that use variable resistors to determine signal voltage based on throttle plate position. TPS 1 will read low voltage when closed and TPS 2 will read high voltage when closed. The TPS 1 and TPS 2 percentages are calculated from these voltages. Although the voltages are different, the calculated values for the throttle position percentages should be very close to the same. The TPS values are used by the ECM to determine if the throttle is opening as commanded. This fault will set if TPS 1 is 20% (or more) lower than TPS 2. At this point the throttle is considered to be out of specification, or there is a problem with the TPS signal circuit. The MIL command is on and the engine will shutdown.



Step	Action	Value(s)	Yes	No
1	Did you perform the On-Board (OBD) System Check?	-	Go to Step (2)	Go to OBD System Check Section
2	<ul style="list-style-type: none"> <li>Key ON, Engine OFF</li> <li>DST (Diagnostic Scan Tool) connected in System Data Mode</li> </ul> Does the DST display more than a 20% difference between TPS 1 and TPS 2 voltage?		Go to Step (3)	Intermittent problem Go to Intermittent section
3	<ul style="list-style-type: none"> <li>Key OFF</li> <li>Disconnect electronic throttle connector C017</li> <li>Key ON</li> <li>Change DST mode to DBW (drive by wire) test mode</li> </ul> Is the voltage for TPS 1 less than 0.1 volts?		Go to Step (5)	Go to Step (4)
4	<ul style="list-style-type: none"> <li>Key OFF</li> <li>Disconnect ECM wiring harness connector C001</li> <li>Key ON</li> <li>Using a DVOM check for voltage between ECM connector TPS 1 signal pin 20 and engine ground</li> </ul> Do you have voltage?		Repair the TPS 1 circuit shorted to voltage as necessary. Refer to Wiring Repairs in Engine Electrical.	Go to Step (9)
5	<ul style="list-style-type: none"> <li>Jump TPS 1 signal pin 21 to the 5-volt reference pin 3 at connector C017</li> </ul> Does DST display TPS 1 voltage over 4.90 volts		Go to Step (6)	Go to Step (8)
6	<ul style="list-style-type: none"> <li>Inspect wire terminals at throttle connector for damage corrosion or contamination</li> </ul> Any problems found?		Repair the circuit as necessary. Refer to Wiring Repairs in Engine Electrical.	Go to Step (7)
7	<ul style="list-style-type: none"> <li>Replace the electronic Throttles</li> </ul> Is the replacement complete?		Go to Step (12)	-
8	<ul style="list-style-type: none"> <li>Key OFF</li> <li>Disconnect ECM wire harness connector C001</li> <li>Using a DVOM check for continuity between throttle connector TPS 1 signal pin 21 and ECM connector TPS 1 signal pin 5</li> </ul> Do you have continuity between them?		Go to Step (9)	Repair the open circuit as necessary. Refer to Wiring Repairs in Engine Electrical.

Step	Action	Value(s)	Yes	No
9	<ul style="list-style-type: none"> <li>Using a DVOM check for continuity between throttle connector signal ground pin 2 and ECM connector signal ground pin 3</li> </ul> Do you have continuity between them?		Go to Step (10)	Repair the open circuit as necessary Refer to Wiring Repairs in Engine Electrical.
10	<ul style="list-style-type: none"> <li>Inspect ECM connector terminals for damage corrosion or contamination.</li> </ul> Any problems found?		Repair the circuit as necessary. Refer to Wiring Repairs in Engine Electrical	Go to Step (11)
11	<ul style="list-style-type: none"> <li>Replace ECM</li> </ul> Is the replacement complete?		Go to Step (12)	-
12	<ul style="list-style-type: none"> <li>Remove all test equipment except the DST.</li> <li>Connect any disconnected components, fuses, etc.</li> <li>Using the DST clear DTC information from the ECM.</li> <li>Turn the ignition OFF and wait 30 seconds.</li> <li>Start the engine and operate the vehicle to full operating temperature</li> <li>Observe the MIL</li> <li>Observe engine performance and drivability</li> <li>After operating the engine within the test parameters of DTC-121 check for any stored codes.</li> </ul> Does the engine operate normally with no stored codes?		System OK	Go to OBD System Check

## DTC 122-TPS 1 Low Voltage (SPN 51:FMI 4)

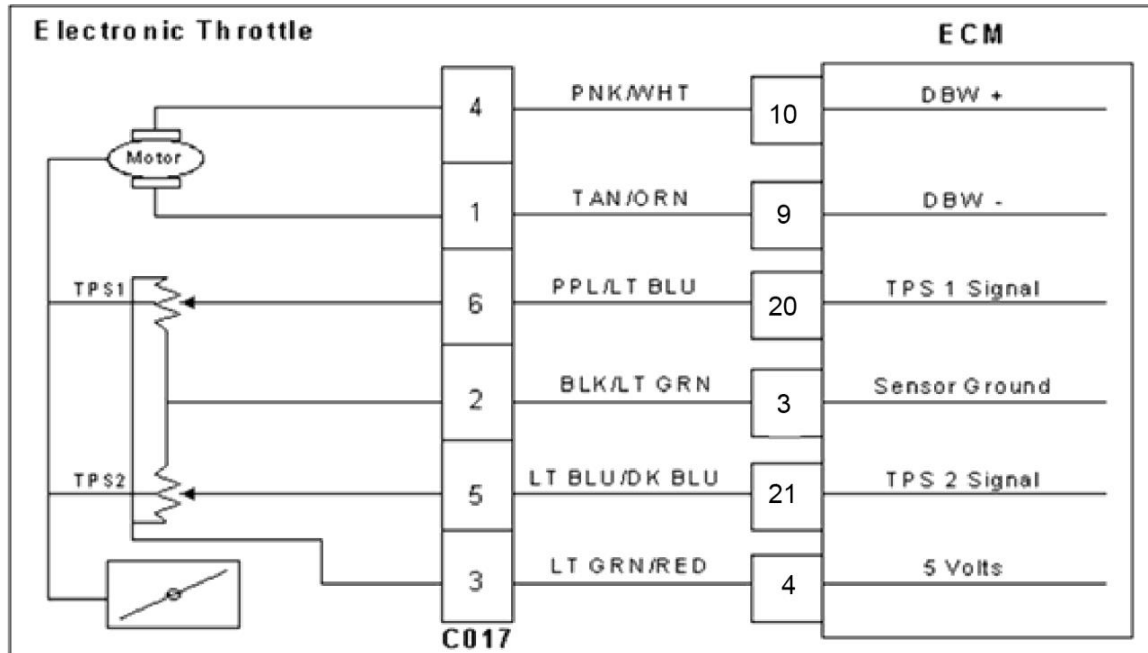

### Conditions for Setting the DTC

- Throttle Position Sensor 1
- Check Condition-Cranking or Running
- Fault Condition-TPS sensor less than 0.200 volts
- MIL-ON during active fault
- Engine shutdown

### Circuit Description

Dual throttle Position Sensors are used within the throttle that use variable resistors to determine signal voltage based on throttle plate position. TPS1 will read lower voltage when closed and TPS2 will read higher voltage when closed. The TPS1 and TPS2 percentages are calculated from these voltages. Although the voltages are different, the calculated values for the throttle position percentages should be very close to the same. The TPS values are used by the ECM to determine if the throttle is opening as commanded. The TPS is not serviceable and in the event of a failure the electronic throttle assembly must be replaced. This fault will set if the TPS 1 voltage is less than 0.200 volts. The MIL command is ON and the engine will shut down.

Step	Action	Value(s)	Yes	No
1	Did you perform the On-Board (OBD) System Check?	-	Go to Step (2)	Go to OBD System Check Section
2	<ul style="list-style-type: none"> <li>Key ON, Engine OFF</li> <li>DST (Diagnostic Scan Tool) connected inDBW (Drive by Wire) throttle test mode</li> </ul> Does the DST display TPS 1 voltage of 0.200volts or less with the throttle closed?		Go to Step (4)	Go to Step (3)
3	<ul style="list-style-type: none"> <li>Slowly depress Foot Pedal while observingTPS 1 voltage</li> </ul> Does TPS 1 voltage ever fall below 0.200 volts?		Go to Step (4)	Intermittent problem Go to Intermittent section
4	<ul style="list-style-type: none"> <li>Key OFF</li> <li>Disconnect the electronic throttle connector C017</li> <li>Jump the 5-volt reference circuit pin 3 and TPS 1 signal circuit pin 21 together at the throttle connector</li> <li>Key ON</li> </ul> Does DST display TPS 1 voltage of 4.0 volts or greater?		Go to Step (7)	Go to Step (5)
5	<ul style="list-style-type: none"> <li>Key OFF</li> <li>Disconnect ECM wire harness connector C001</li> <li>Using a DVOM check continuity between the electronic throttle connector signal pin 6 and ECM connector TPS 1 signal pin 20</li> </ul> Do have continuity between them?		Go to Step (6)	Repair the circuit as necessary. Refer to Wiring Repairs in Engine Electrical.
6	<ul style="list-style-type: none"> <li>Replace ECM</li> </ul> Is the replacement complete?		Go to Step (9)	-
7	<ul style="list-style-type: none"> <li>Inspect the throttle wire harness connector terminals for damage, corrosion or contamination</li> </ul> Did you find a problem?		Repair the circuit as necessary. Referto Wiring Repairs in Engine Electrical.	Go to Step (8)
8	<ul style="list-style-type: none"> <li>Replace the electronic throttles</li> </ul> the replacement complete?		Go to Step (9)	-

Step	Action	Value(s)	Yes	No
9	<ul style="list-style-type: none"> <li>• Remove all test equipment except the DST.</li> <li>• Connect any disconnected components, fuses, etc.</li> <li>• Using the DST clear DTC information from the ECM.</li> <li>• Turn the ignition OFF and wait 30 seconds.</li> <li>• Start the engine and operate the vehicle to full operating temperature</li> <li>• Observe the MIL</li> <li>• Observe engine performance and drivability</li> <li>• After operating the engine within the test parameters of DTC-122 check for any stored codes.</li> </ul> <p>Does the engine operate normally with no stored codes?</p>		System OK	Go to OBD System Check

## DTC 123-TPS 1 High Voltage (SPN 51:FMI 3)

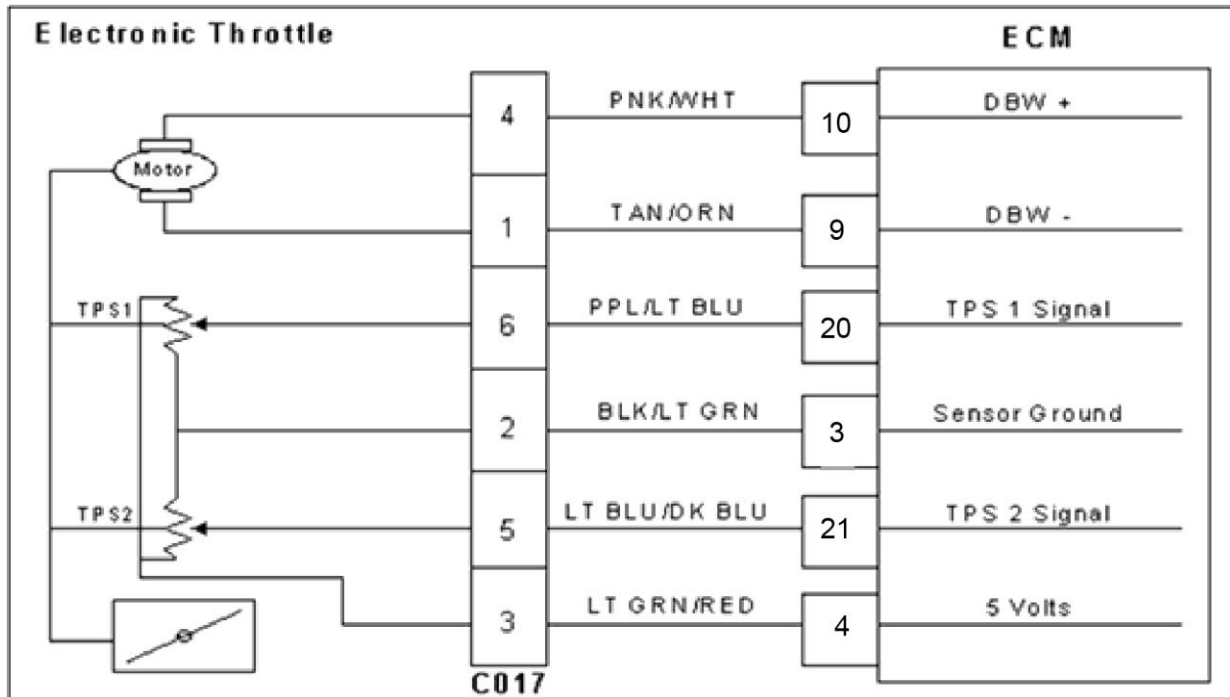

### Conditions for Setting the DTC

- Throttle Position Sensor 1
- Check Condition-Cranking or Running
- Fault Condition-TPS sensor voltage exceeds 4.800 volts
- MIL-ON during active fault
- Engine shutdown

### Circuit Description

Dual throttle Position Sensors are used within the throttle that use variable resistors to determine signal voltage based on throttle plate position. TPS1 will read lower voltage when closed and TPS2 will read higher voltage when closed. The TPS1 and TPS2 percentages are calculated from these voltages. Although the voltages are different, the calculated values for the throttle position percentages should be very close to the same. The TPS values are used by the ECM to determine if the throttle is opening as commanded. The TPS is not serviceable and in the event of a failure the electronic throttle assembly must be replaced. This fault will set if the TPS 1 voltage exceeds 4.800 volts. The MIL command is ON and the engine will shut down.

Step	Action	Value(s)	Yes	No
1	Did you perform the On-Board (OBD) System Check?	-	Go to Step (2)	Go to OBD System Check Section
2	<ul style="list-style-type: none"> <li>Key ON, Engine OFF</li> <li>DST (Diagnostic Scan Tool) connected</li> </ul> Does the DST display TPS 1 voltage of 4.800volts or greater with the throttle closed?		Go to Step (4)	Go to Step (3)
3	<ul style="list-style-type: none"> <li>Slowly depress Foot Pedal while observing TPS 1 voltage</li> </ul> Does TPS 1 voltage ever exceed 4.800 volts?		Go to Step (4)	Intermittent problem Go to Intermittent section
4	<ul style="list-style-type: none"> <li>Key OFF</li> <li>Disconnect electronic throttle connector</li> <li>Key ON</li> </ul> Does DST display TPS 1 voltage less than 0.2volts?		Go to Step (7)	Go to Step (5)
5	<ul style="list-style-type: none"> <li>Key OFF</li> <li>Disconnect ECM wire harness connector C001</li> <li>Key ON</li> <li>Using a DVOM check for voltage between TPS 1 signal at the ECM connector pin 20 and engine ground</li> </ul> Do you have voltage?		Repair the circuit as necessary. Refer to Wiring Repairs in Engine Electrical.	Go to Step (6)
6	<ul style="list-style-type: none"> <li>Replace ECM</li> </ul> Is the replacement complete?		Go to Step (11)	-
7	<ul style="list-style-type: none"> <li>Back probe sensor ground circuit at the ECM side of the wire harness pin 3 with a test light connected to battery voltage</li> </ul> Does the test light come on?		Go to Step (8)	Go to Step (10)
8	<ul style="list-style-type: none"> <li>Inspect the electronic throttle connector terminals for damage, corrosion or contamination</li> </ul> Did you find a problem?		Repair the circuit as necessary. Refer to Wiring Repairs in Engine Electrical.	Go to Step (9)
9	<ul style="list-style-type: none"> <li>Replace the electronic throttles</li> </ul> Is the replacement complete?		Go to Step (11)	-
10	<ul style="list-style-type: none"> <li>Key OFF</li> <li>Disconnect ECM connector C001</li> <li>Using a DVOM check for continuity between the electronic throttle connector sensor ground pin 2 and ECM connector TPS 1 sensor ground pin 3</li> </ul> Do have continuity between them?		Go to Step (6)	Repair the circuit as necessary. Refer to Wiring Repairs in Engine Electrical.

Step	Action	Value(s)	Yes	No
11	<ul style="list-style-type: none"> <li>• Remove all test equipment except the DST.</li> <li>• Connect any disconnected components, fuses, etc.</li> <li>• Using the DST clear DTC information from the ECM.</li> <li>• Turn the ignition OFF and wait 30 seconds.</li> <li>• Start the engine and operate the vehicle to full operating temperature</li> <li>• Observe the MIL</li> <li>• Observe engine performance and drivability</li> <li>• After operating the engine within the test parameters of DTC-123 check for any stored codes.</li> </ul> <p>Does the engine operate normally with no stored codes?</p>		System OK	Go to OBD System Check



## **DTC 127-IAT Higher Than Expected 2 (SPN 105:FMI 0)**

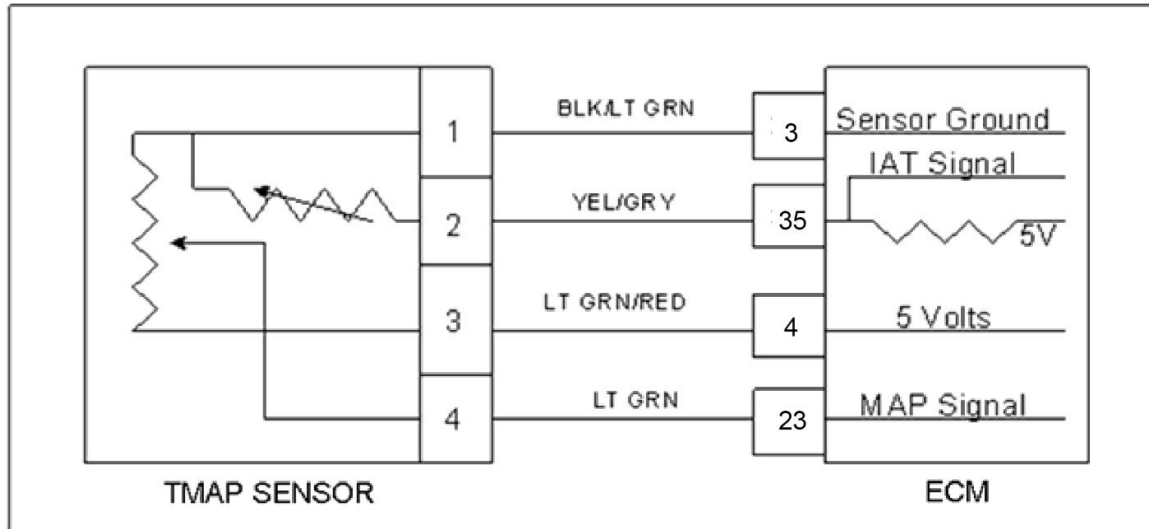

### **Conditions for Setting the DTC**

- Intake Air Temperature
- Check Condition-Engine Running
- Fault Condition-Intake Air Temperature greater than 210 degrees F. with engine speed greater than 700 rpm
- Fault condition must be active for longer than 120 seconds
- MIL-ON for active fault
- Engine will de-rate to 1,400 rpms.

### **Circuit Description**

The TMAP is a combined IAT (Intake Air Temperature) and MAP (Manifold Absolute Pressure) sensor. A temperature sensitive resistor is used in the TMAP located in the intake manifold of the engine. It is used to monitor incoming air temperature, and the output in conjunction with other sensors is used to determine the airflow to the engine. The ECM provides a voltage divider circuit so that when the air is cool, the signal reads a higher voltage, and lower when warm. This fault will set if the intake air temperature is greater than 210 degrees F. with engine speed greater than 700 rpm. The MIL light command is on during this active fault and the engine will derate to 1,400 rpms.

### **Diagnostic Aid**

- This fault will set when inlet air is much hotter than normal. The most common cause of high inlet air temperature is a problem with the inlet air system. Ensure that the air inlet is not obstructed, modified, or damaged.
- Inspect the air inlet system for cracks or breaks that may allow unwanted under hood air in to the air inlet system
- If none of the above can be found, follow the diagnostic steps for DTC 112-IAT Low Voltage

## DTC 128-Failed to Reach Operating Temperature (SPN 110: FMI 31)

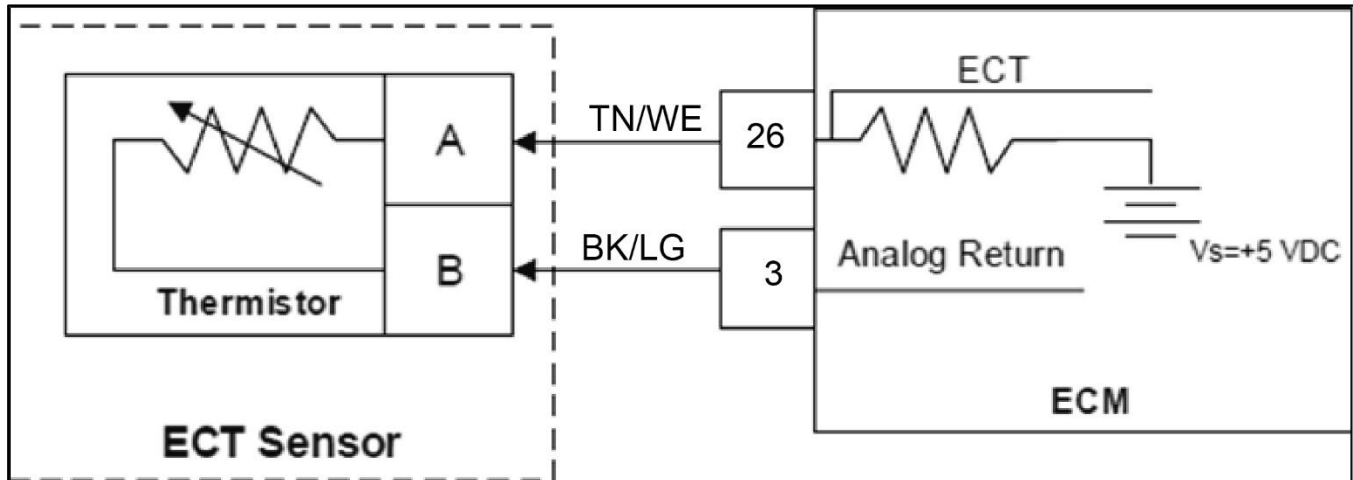

### Conditions for Setting the DTC

- Engine Coolant Temperature Sensor
- Check Condition-Engine Running
- Fault Condition-Operating temperature did not reach desired temperature within expected time
- Fault condition must be active for longer than 30 seconds
- MIL-ON for active fault

### Possible Causes for Fault:

- Thermostat stuck open and ECT temperature is unable to reach the expected temperature.
- Check for proper operation of the thermostat to ensure it is opening and closing as expected.
- Check for the proper thermostat rating currently installed in the engine. A thermostat that is rated with a higher opening temperature could cause the DTC.

### Circuit Description

The Engine Coolant Temperature sensor is a thermistor (temperature sensitive resistor) located in the engine coolant. Some engines use a CHT sensor that is located in the coolant in the cylinder head. Some engines use an ECT (Engine Coolant Temperature) sensor that is located in the coolant near the thermostat. If the engine is equipped with a CHT sensor then the ECT value is estimated. If equipped with an ECT sensor then the CHT value is estimated. They are used for engine airflow calculation, ignition timing control, to enable certain features, and for engine protection.

The ECM provides a voltage divider circuit so when the sensor reading is cool the sensor reads higher voltage, and lower when warm.

## DTC 129-BP Low Pressure (SPN 108: FMI 1)

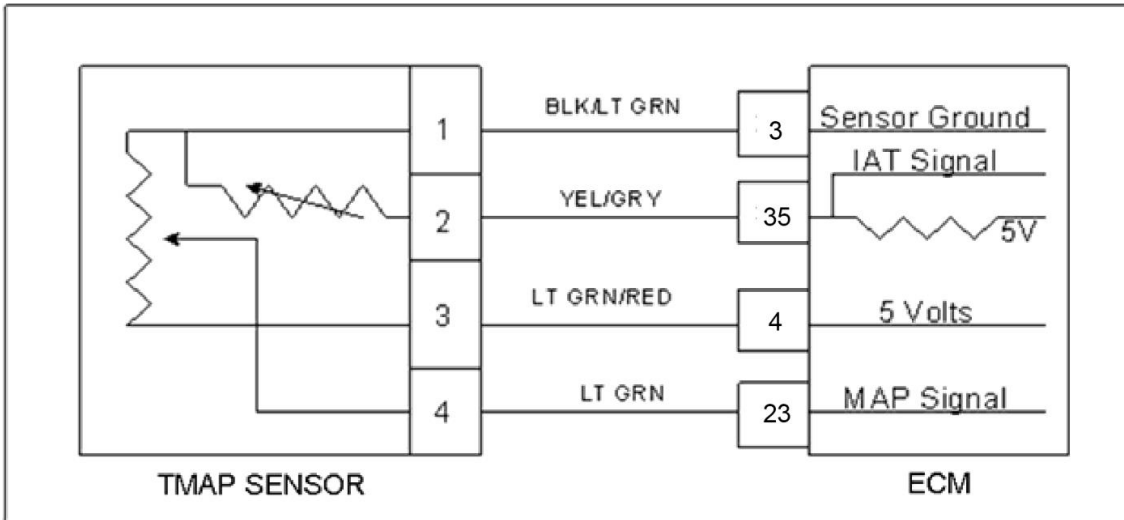

### Conditions for Setting the DTC

- Barometric Pressure
- Check Condition-Key ON
- Fault Condition-BP less than 8.30 psia
- MIL-ON for active fault
- Adaptive-Disabled

### Circuit Description

The BP (Barometric Pressure) is estimated from the TMAP sensor. The barometric pressure value is used for fuel and airflow calculations. This fault sets in the event the BP value is out of the normal range.

Step	Action	Value(s)	Yes	No
1	Did you perform the On-Board (OBD) System Check?	-	Go to Step (2)	Go to OBD System Check Section
2	<ul style="list-style-type: none"> <li>Key ON.</li> <li>DST (Diagnostic Scan Tool) connected in System Data Mode</li> </ul> Does DST display BP pressure of 8.30 psia or less?		Go to Step (3)	Intermittent problem. Go to Intermittent section
3	<ul style="list-style-type: none"> <li>Key OFF</li> <li>Disconnect the TMAP sensor connector</li> <li>Jump the 5-volt reference pin 3 and MAP signal pin 4 together</li> <li>Key ON</li> </ul> Does the DST display BP pressure of 16.00 psia or greater?		Go to Step (4)	Go to Step (8)
4	<ul style="list-style-type: none"> <li>Inspect TMAP connector and wire harness connector terminals for corrosion, contamination or mechanical damage</li> </ul> Any problems found?		Repair the circuit as necessary. Refer to Wiring Repairs in Engine Electrical.	Go to Step (5)
5	<ul style="list-style-type: none"> <li>Key OFF</li> <li>Disconnect ECM connector C001</li> <li>Check for continuity between TMAP sensor connector pin 4 and ECM connector pin 23.</li> </ul> Do you have continuity between them?		Go to Step (6)	Repair the circuit as necessary. Refer to Wiring Repairs in Engine Electrical.
6	<ul style="list-style-type: none"> <li>Check for continuity between TMAP sensor connector 5-volt supply pin 3 and ECM connector pin 4.</li> </ul> Do you have continuity between them?		Go to Step (7)	Repair the circuit as necessary. Refer to Wiring Repairs in Engine Electrical.
7	<ul style="list-style-type: none"> <li>Check for continuity between TMAP sensor connector ground pin 1 and ECM connector pin 3.</li> </ul> Do you have continuity between them?		Go to Step (17)	Repair the circuit as necessary. Refer to Wiring Repairs in Engine Electrical.

Step	Action	Value(s)	Yes	No
8	<ul style="list-style-type: none"> <li>Remove the Jumper that was installed during step 3</li> <li>Probe TMAP connector signal circuit pin 4 with a test light connected to battery voltage</li> </ul> Does the DST display BP pressure of 16.00 psia or greater?		Go to Step (9)	Go to Step (13)
9	<ul style="list-style-type: none"> <li>Key OFF</li> <li>Disconnect ECM connector C001</li> <li>Check for continuity between TMAP sensor connector pin 3 and ECM connector pin 4</li> </ul> Do you have continuity between them?		Go to Step (10)	Repair the circuit as necessary. Refer to Wiring Repairs in Engine Electrical.
10	<ul style="list-style-type: none"> <li>Check for continuity between TMAP sensor connector 5 volt reference pin 3 and engine ground</li> </ul> Do you have continuity?		Repair the open ground circuit as necessary. Refer to Wiring Repairs in Engine Electrical.	Go to Step (11)
11	<ul style="list-style-type: none"> <li>Inspect TMAP and ECM connector pins for corrosion, contamination or mechanical damage</li> </ul> Any problems found?		Repair the circuit as necessary. Refer to Wiring Repairs in Engine Electrical.	Go to Step (16)
12	<ul style="list-style-type: none"> <li>Replace ECM. Refer to ECM replacement in the Engine Controls Section.</li> </ul> Is the replacement complete?		Go to Step (17)	-
13	<ul style="list-style-type: none"> <li>Disconnect ECM connector C001</li> <li>Check for continuity between TMAP sensor connector pin 4 and ECM pin 23.</li> </ul> Do you have continuity between them?		Go to Step (14)	Repair the circuit as necessary. Refer to Wiring Repairs in Engine Electrical.
14	<ul style="list-style-type: none"> <li>Check for continuity between TMAP sensor connector pin 4 and engine ground</li> </ul> Do you have continuity?		Repair the open ground circuit as necessary. Refer to Wiring Repairs in Engine Electrical.	Go to Step (15)

Step	Action	Value(s)	Yes	No
15	<ul style="list-style-type: none"> <li>Inspect ECM connector and wire harness connector pins for corrosion, contamination or mechanical damage</li> </ul> Any problems found?		Repair the circuit as necessary. Refer to Wiring Repairs in Engine Electrical.	Go to Step (16)
16	<ul style="list-style-type: none"> <li>Replace ECM. Refer to ECM replacement in the Engine Controls Section.</li> </ul> Is the replacement complete?		Go to Step (18)	-
17	<ul style="list-style-type: none"> <li>Replace TMAP sensor</li> </ul> Is the replacement complete?		Go to Step (18)	-
18	<ul style="list-style-type: none"> <li>Remove all test equipment except the DST.</li> <li>Connect any disconnected components, fuses, etc.</li> <li>Using the DST clear DTC information from the ECM.</li> <li>Turn the ignition OFF and wait 30 seconds.</li> <li>Start the engine and operate the vehicle to full operating temperature</li> <li>Observe the MIL</li> <li>Observe engine performance and drivability</li> <li>After operating the engine within the test parameters of DTC-129 check for any stored codes.</li> </ul> Does the engine operate normally with no stored codes?		System OK	Go to OBD System Check

## **DTC 134-EGO 1 Pre Cat Open/Lazy (SPN 3217:FMI 5)**

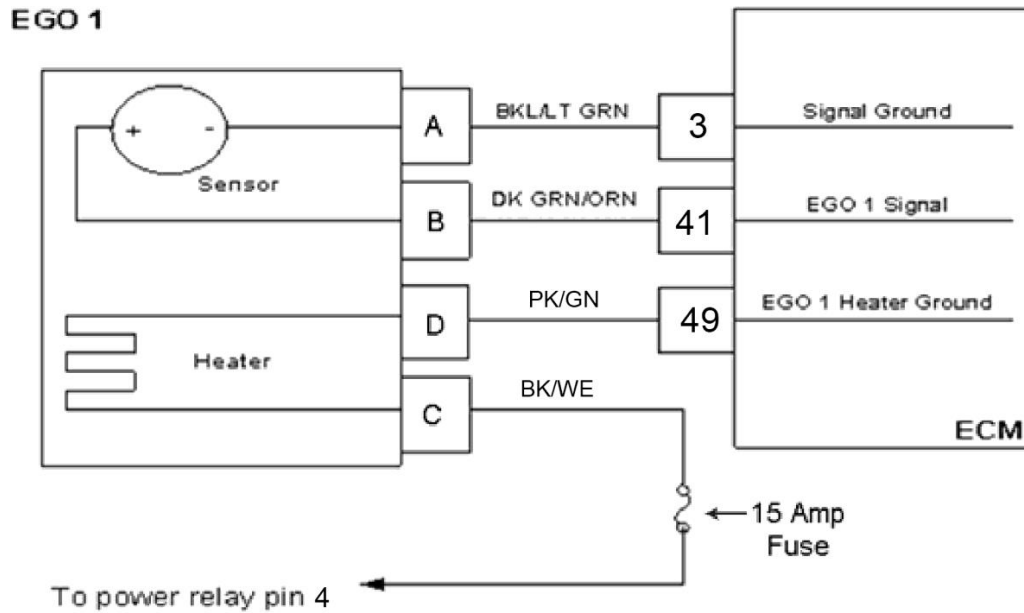

### **Conditions for Setting the DTC**

- Heated Oxygen Sensor
- Check condition-Engine running
- Fault condition-EGO 1 pre catalyst persistently cold for more than 120 seconds
- MIL-ON during active fault
- Adaptive-Disabled during active fault
- Closed Loop-Disabled during active fault

### **Circuit Description**

The EGO 1 sensor is used to determine if the fuel flow to the engine is correct by measuring the oxygen content in the exhaust gas. The ECM uses this information to correct the fuel flow with the Closed Loop multiplier and the Adaptive multiplier. This fault will set if EGO 1 is cold, non-responsive, or inactive for more than 120 seconds.

Step	Action	Value(s)	Yes	No
1	Did you perform the On-Board (OBD) System Check?	-	Go to Step (2)	Go to OBD System Check Section
2	<ul style="list-style-type: none"> <li>Key ON, Engine Running</li> <li>DST (Diagnostic Scan Tool) connected in System Data Mode</li> <li>Run engine to full operating temperature and then idle for a minimum of 2 minutes</li> </ul> Does DST display EGO 1 voltage fixed between 0.4 and 0.5 volts after at least 2 minutes of idlerun time?		Go to Step (3)	Intermittent problem. See Electrical Section Intermittent Electrical Diagnosis
3	<ul style="list-style-type: none"> <li>Key OFF</li> <li>Disconnect EGO 1 connector C005</li> <li>Key ON</li> <li>Using a DVOM check for voltage between EGO 1 connector pins C and D</li> </ul> (Check must be made within 30 seconds or before power relay shuts down) Do you have voltage?		Go to Step (8)	Go To Step (4)
4	<ul style="list-style-type: none"> <li>Key OFF</li> <li>Using a DVOM check for voltage between EGO 1 connector pin C and engine ground</li> <li>Key ON</li> </ul> (Check must be made within 30 seconds or before power relay shuts down) Do you have voltage?	System Voltage	Go to Step (5)	Repair system power relay open circuit
5	<ul style="list-style-type: none"> <li>Disconnect ECM connector C001</li> <li>Using a DVOM check for continuity between EGO 1 connector pin D and ECM connectorpin 49</li> </ul> Do you have continuity?		Go to Step (6)	Repair open heater ground circuit
6	<ul style="list-style-type: none"> <li>Inspect wire harness connector C005 pins Band D and C001 pins 41 and 49 for damage, corrosion or contamination</li> </ul> Did You find a problem?		Correct the problem as required see Electrical Section wire harness repair	Go to Step (7)
7	<ul style="list-style-type: none"> <li>Replace ECM</li> </ul> Is the replacement complete?		Go to Step (11)	-



Step	Action	Value(s)	Yes	No
8	<ul style="list-style-type: none"> <li>Key OFF</li> <li>Disconnect ECM wire harness connector C001</li> <li>Using a DVOM check for continuity between EGO 1 pin B and ECM connector pin 41</li> </ul> Do you have continuity?		Go to Step (9)	Repair open EGO 1 circuit
9	<ul style="list-style-type: none"> <li>Using a DVOM check for continuity between EGO 1 pin A and ECM connector pin 3</li> </ul> Do you have continuity?		Go to Step (10)	Repair open EGO 1 signal ground
10	<ul style="list-style-type: none"> <li>Replace EGO 1 sensor</li> </ul> Is the replacement complete?		Go to Step (11)	-
11	<ul style="list-style-type: none"> <li>Remove all test equipment except the DST.</li> <li>Connect any disconnected components, fuses, etc.</li> <li>Using the DST clear DTC information from the ECM.</li> <li>Turn the ignition OFF and wait 30 seconds.</li> <li>Start the engine and operate the vehicle to full operating temperature</li> <li>Observe the MIL</li> <li>Observe engine performance and drivability</li> <li>After operating the engine within the test parameters of DTC-134 check for any stored codes.</li> </ul> Does the engine operate normally with no stored codes?		System OK	Go to OBD System Check

## DTC 148 - Fuel Run-out Longer Than Expected

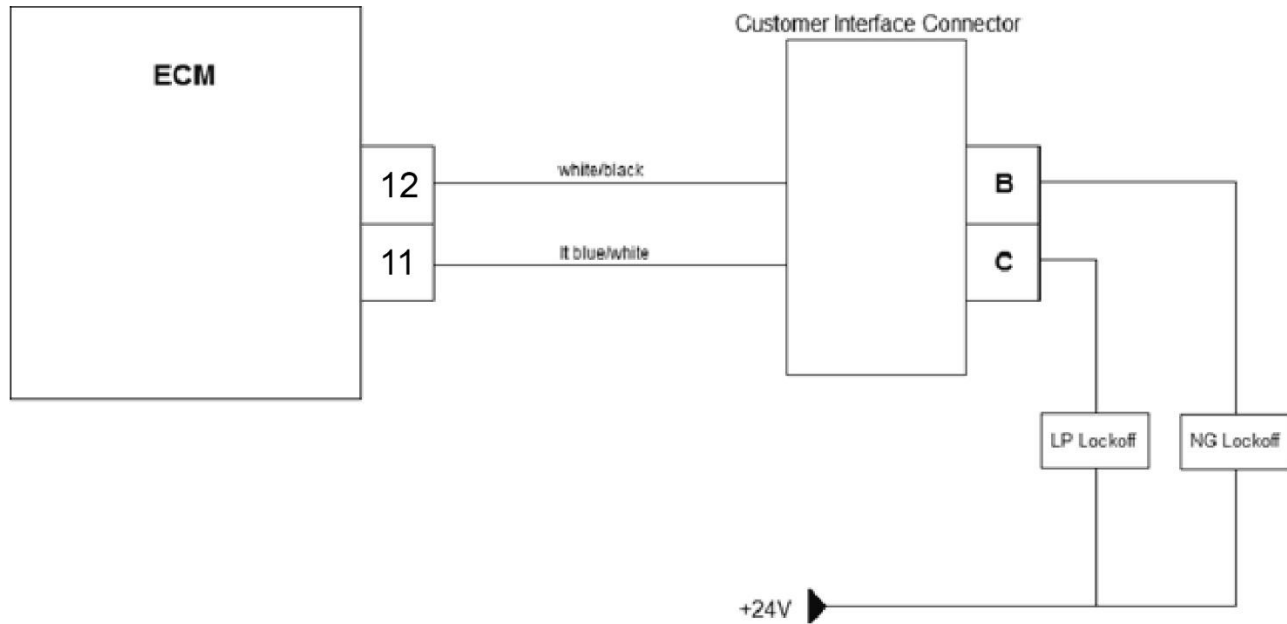

### Conditions for Setting the DTC

- Check Condition: Key OFF
- Fault Condition: Engine run down time greater than 10 seconds
- MIL-ON

### Circuit Description

The fuel shut off valves are supplied system battery power from the VSW fused source. The ECM then provides a path to ground to turn the valve on. This fault will set in the event the engine continues to run for more than 10 seconds after the key is turned off. This fault indicates a possible problem with the electric fuel shut-off valve, or a wiring issue.

## DTC 148 - Fuel Run-out Longer Than Expected

**Note:**

Ensure to check voltage and ground separately.

Step	Action	Value(s)	Yes	No
1	Did you perform the On-Board (OBD) Sys-Check?	-	Go to Step (2)	
2	Disconnect the natural gas lockoff solenoid connector. Using a DVOM check for power across terminals A and B while cranking the engine, then turn the key to the OFF position Did the voltage immediately turn OFF with the	System Voltage	Go to Step (3)	Go to Step (5)
3	Turn off the natural gas manual valve. Start the engine and let it idle until the engine stops. (THIS MAY TAKE SEVERAL MINUTES) Did the engine ever stop?		Intermittent problem. See intermittent problems in the electrical section of this manual.	Go to Step (4)
4	Replace the natural gas lockoff solenoid. Is the replacement complete?		Go to Step (8)	-
5	Key OFF Disconnect the ECM wire harness header connector Using a DVOM check for continuity between header connector pin 12 and engine ground Do you have continuity?		Repair the natural gas solenoid control short to ground	Go to Step (6)
6	Inspect the ECM wire harness and connector for damage corrosion or contamination. Did you find a problem?		Correct the problem as required. See wire harness repair.	Go to Step (7)
7	Replace the ECM Is the replacement complete?		Go to Step (8)	

Step	Action	Value(s)	Yes	No
8	<p>Remove all test equipment except the DST.</p> <p>Connect any disconnected components, fuses, etc.</p> <p>Using the DST clear DTC information from the ECM.</p> <p>Turn the ignition OFF and wait 30 seconds. Start the engine and operate the vehicle to full operating temperature</p> <p>Observe the MIL</p> <p>Observe engine performance and drivability After operating the engine within the test parameters of DTC-359 check for any stored codes.</p> <p>Does the engine operate normally with no stored codes?</p>		System OK	Go to OBD System Check

## DTC 154-EGO 2 Post Cat Open/Lazy (SPN 3227:FMI 5)

EGO 1

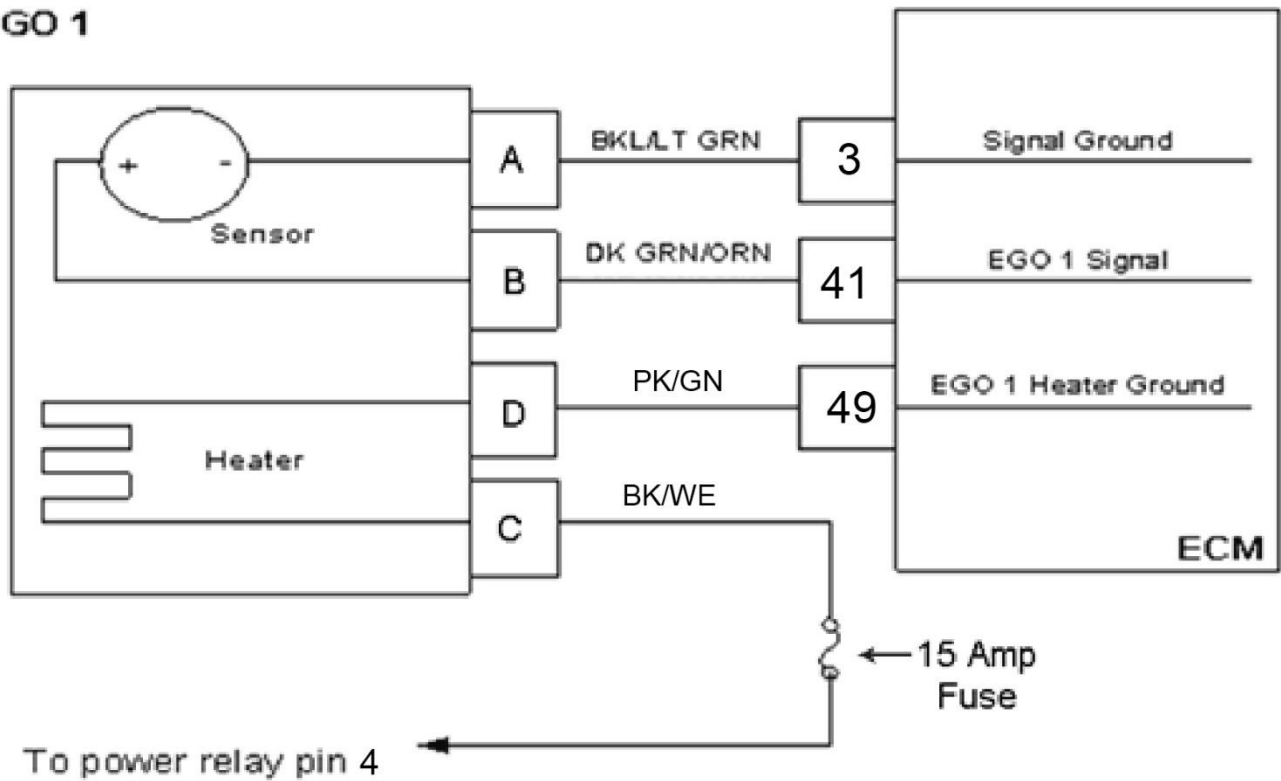

### Conditions for Setting the DTC

- Heated Oxygen Sensor
- Check condition-Engine running
- Fault condition-EGO 2 cold persistently for more than 120 seconds
- MIL-ON during active fault
- Adaptive-Disabled during active fault
- Closed Loop-Disabled during active fault

### Circuit Description

The EGO 2 sensor is used to monitor the efficiency of the catalytic converter. The ECM compares the EGO 1 and EGO 2 voltage signals to determine this. This fault will set if EGO 2 is cold, non-responsive, or inactive for more than 120 seconds.

Step	Action	Values(s)	Yes	No
1	Did you perform the On-Board (OBD) System Check?	-	Go to Step (2)	Go to OBD System Check Section
2	<ul style="list-style-type: none"> <li>• Key ON, Engine Running</li> <li>• DST (Diagnostic Scan Tool) connected in SystemData Mode</li> <li>• Run engine to full operating temperature and then idle for a minimum of 2 minutes</li> </ul> <p>Does DST display EGO 2 voltage fixed between 0.4 and 0.5 Volts after at least 2 minutes of idle run time?</p>		Go to Step (3)	Intermittent problem. See Electrical Section Intermittent Electrical Diagnosis
3	<ul style="list-style-type: none"> <li>• Key OFF</li> <li>• Disconnect EGO 2 connector C005</li> <li>• Key ON</li> <li>• Using a DVOM check for voltage between EGO 2 connector pins C and D</li> </ul> <p><b>(Check must be made within 30 seconds or before power relay shuts down)</b></p> <p>Do you have voltage?</p>		Go to Step (8)	Go to Step (4)
4	<ul style="list-style-type: none"> <li>• Key OFF</li> <li>• Using a DVOM check for voltage between EGO 2 connector pin C and engine ground</li> <li>• Key ON</li> </ul> <p><b>(Check must be made within 30 seconds or before power relay shuts down)</b></p> <p>Do you have voltage?</p>	System Voltage	Go to step (5)	Repair system power relay open circuit
5	<ul style="list-style-type: none"> <li>• Disconnect ECM connector C001</li> <li>• Using a DVOM check for continuity between EGO 2 connector pin D and ECM connector pin 49</li> </ul> <p>Do you have continuity?</p>		Go to Step(6)	Repair open heater ground circuit

Step	Action	Values(s)	Yes	No
6	<ul style="list-style-type: none"> <li>Inspect wire harness connector C005 pins C and D and C001 pins 41 and 49 for damage, corrosion, or contamination</li> </ul> <p>Did you find a problem?</p>		Correct the problem as required. See Electrical Section Wire Harness Repair	Go to Step (7)
7	<ul style="list-style-type: none"> <li>Replace ECM</li> </ul> <p>Is the replacement complete?</p>		Go to Step (11)	-
8	<ul style="list-style-type: none"> <li>Key OFF</li> <li>Disconnect ECM wire harness connector C001</li> <li>Using a DVOM check for continuity between EGO 2 connector pin B and ECM connector pin 41</li> </ul> <p>Do you have continuity?</p>		Go to Step (9)	Repair open EGO 2 circuit
9	<ul style="list-style-type: none"> <li>Using a DVOM check for continuity between EGO 2 pin A and ECM connector pin 3</li> </ul> <p>Do you have continuity?</p>		Go to Step (10)	Repair open EGO 2 signal ground
10	<ul style="list-style-type: none"> <li>Replace EGO 2 sensor</li> </ul> <p>Is the replacement complete?</p>		Go to Step (11)	-
11	<ul style="list-style-type: none"> <li>Remove all test equipment except the DST</li> <li>Connect any disconnected components, fuses, etc.</li> <li>Using the DST clear DTC information from the ECM.</li> <li>Turn the ignition OFF and wait 30 seconds.</li> <li>Start the engine and operate the vehicle to full operating temperature</li> <li>Observe MIL</li> <li>Observe engine performance and drivability</li> <li>After operating the engine within the test parameters of DTC-154 check for any stored codes.</li> </ul> <p>Does the engine operate normally with no stored codes?</p>		SystemOK	Go to OBD System Check

## DTC 171-Adaptive Learn High Gasoline (SPN 4237:FMI 0)

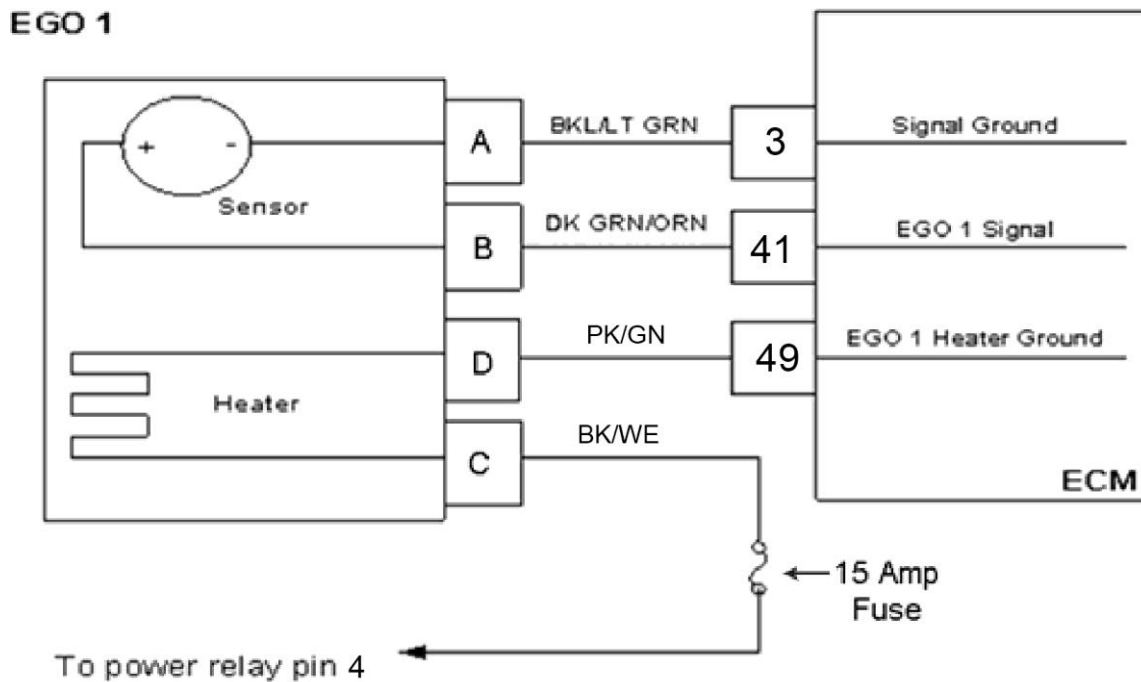

### Conditions for Setting the DTC

- Heated Oxygen Sensor
- Check Condition-Engine Running
- Fault Condition-Adaptive multiplier out of range greater than 30%
- MIL-ON

### Circuit Description

The EGO 1 sensor is used to determine if the fuel flow to the engine is correct by measuring the oxygen content in the exhaust gas. The ECM uses this information to correct the fuel flow with the Closed Loop multiplier and Adaptive multiplier. This fault will set if the adaptive multiplier exceeds the limits of normal operation. Always run the fuel system diagnostic checks before using the following diagnostic chat.

### Diagnostic Aid

**Oxygen Sensor Wire** Heated Oxygen sensor wires may be mis-routed and contacting the exhaust manifold.

**Vacuum Leaks** Large vacuum leaks and crankcase leaks can cause a lean exhaust condition at especially at light load.

**Fuel Pressure** Low fuel pressure, faulty fuel pressure sensor, faulty pump, or contaminated fuel filter can cause the system to run lean.

**Exhaust Leaks** If there is an exhaust leak, outside air can be pulled into the exhaust and past the O<sub>2</sub> sensor causing a false lean condition.

**Fuel Quality** Contaminated or spoiled fuel can cause the fuel system to be lean.

**Ground Problem** ECM grounds must be clean, tight and in the proper location.



Step	Action	Value(s)	Yes	No
1	<ul style="list-style-type: none"> <li>Perform the On-Board (OBD) System Check? Are any other DTCs present?</li> </ul>		Go to Step (3)	Go to Step (2)
2	<p>Visually and physically check the following items:</p> <ul style="list-style-type: none"> <li>The air intake duct for being collapsed or restricted</li> <li>The air filter for being plugged</li> <li>System power fuses are good and in the proper location</li> <li>The EGO 1 sensor installed securely, and the wire leads not contacting the exhaust manifold or ignition wires</li> <li>ECM grounds must be clean and tight. Refer to Engine Electrical Power and Ground Distribution</li> <li>Fuel System Diagnostics. Refer to Fuel System Diagnostics</li> </ul> <p>Was a repair made?</p>		Go to Step (9)	Go to Step (4)
3	<ul style="list-style-type: none"> <li>Diagnose any other DTC codes before proceeding with this chart. Always repair existing codes starting with the lowest numerical code set first. Have any other DTC codes been detected, diagnosed and repaired?</li> </ul>		Go to Step (9)	Go to Step (4)
4	<ul style="list-style-type: none"> <li>Disconnect EGO1 connector C005</li> <li>Using a DVOM check for voltage between EGO 1 connector pin B and engine ground</li> <li>Key ON</li> </ul> <p>(CHECK MUST BE MADE WITHIN 30 SECONDS OR BEFORE POWER RELAY SHUTS DOWN)</p> <p>Do you have voltage?</p>	System voltage	Go to Step (5)	Repair the open EGO power circuit as necessary. Refer to Wiring Repairs in Engine Electrical.
5	<ul style="list-style-type: none"> <li>Key OFF</li> <li>Disconnect EGO 1 sensor wire harness connector C005</li> <li>Disconnect ECM wire harness connector C001</li> <li>Key ON</li> <li>Using a high impedance DVOM check for continuity between EGO 1 connector signal pin A and engine ground</li> </ul> <p>Do you have continuity?</p>		Repair the shorted circuit as necessary. Refer to Wiring Repairs in Engine Electrical.	Go to Step (6)

Step	Action	Value(s)	Yes	No
6	<ul style="list-style-type: none"> <li>Using a high impedance DVOM check for continuity between EGO 1 connector signal ground pin C and EGO 1 signal pin A</li> </ul> Do you have continuity?		Repair the shorted circuit as necessary. Refer to Wiring Repairs in Engine Electrical.	Go to Step (7)
7	<ul style="list-style-type: none"> <li>Using a high impedance DVOM check for continuity between EGO 1 heater ground pinD and ECM pin 49</li> </ul> Do you have continuity?		Go to Step (8)	Repair the open EGO heater ground
8	<ul style="list-style-type: none"> <li>Replace EGO 1 sensor</li> </ul> Is the replacement complete?		Go to Step (9)	-
9	<ul style="list-style-type: none"> <li>Remove all test equipment except the DST.</li> <li>Connect any disconnected components, fuses, etc.</li> <li>Using the DST clear DTC information from the ECM.</li> <li>Turn the ignition OFF and wait 30 seconds.</li> <li>Start the engine and operate the vehicle to full operating temperature</li> <li>Observe the MIL</li> <li>Observe engine performance and drivability</li> <li>After operating the engine within the test parameters of DTC-1161 check for any stored codes.</li> </ul> Does the engine operate normally with no stored codes?		System OK	Go to OBD System Check

## DTC 172-Adaptive Learn Low (Gasoline) (SPN 4237:FMI 1)

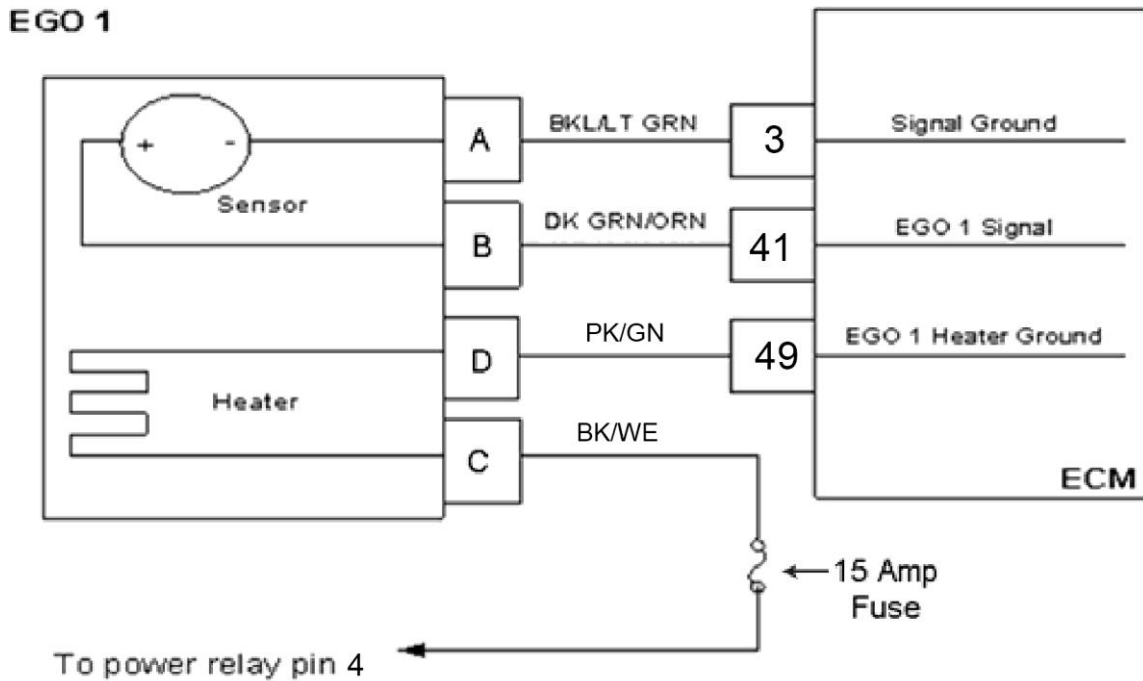

### Conditions for Setting the DTC

- Heated Oxygen Sensor
- Check Condition-Engine running
- Fault Condition-Adaptive multiplier out of range greater than -30%
- MIL-ON

### Circuit Description

The EGO1 sensor is used to determine if the fuel flow to the engine is correct by measuring the oxygen content in the exhaust gas. The ECM uses this information to correct the fuel flow with the Closed Loop multiplier and Adaptive multiplier. This fault will set if the adaptive multiplier exceeds the limits of normal operation. Always run the fuel system diagnostics before using the following diagnostic chart.

### Diagnostic Aid

**Fuel System** High fuel pressure will cause the system to run rich. Fuel pressure is controlled by the ECM using a ground side driver. If the fuel pump is turned on all the time the fuel pressure will increase. Open or leaking injector will cause a rich condition.

**Fuel Quality** A drastic variation in fuel quality may cause the fuel system to run rich.

**Air Filter** A plugged, damaged or modified air filter may cause the system to run rich.

Step	Action	Value(s)	Yes	No
1	<ul style="list-style-type: none"> <li>Perform the On-Board (OBD) System Check? Are any other DTCs present?</li> </ul>		Go to Step (3)	Go to Step (2)
2	<p>Visually and physically check the following items:</p> <ul style="list-style-type: none"> <li>The air intake duct for being collapsed or restricted</li> <li>The air filter for being plugged</li> <li>The EGO sensor is installed securely, and the wire leads not damaged or contacting the secondary ignition wires</li> <li>ECM grounds for being clean and tight.</li> <li>Fuel system diagnostic checks</li> </ul> <p>Was a repair made?</p>		Go to Step (6)	Go to Step (4)
3	<ul style="list-style-type: none"> <li>Diagnose any other DTC codes before proceeding with this chart.</li> </ul> <p>Have any other DTC codes been detected, diagnosed and repaired?</p>		Go to Step (6)	Go to Step (4)
4	<ul style="list-style-type: none"> <li>Key OFF</li> <li>Disconnect EGO sensor wire harness connector C005</li> <li>Disconnect ECM wire harness connector C001</li> <li>Key ON</li> <li>Using a DVOM check for voltage at EGO 1 connector signal pin A and engine ground</li> </ul> <p>Do you have voltage?</p>		Repair the circuit as necessary. Refer to Wiring Repairs in Engine Electrical.	Go to Step (5)
5	<ul style="list-style-type: none"> <li>Replace EGO sensor</li> </ul> <p>Is the replacement complete?</p>		Go to Step (6)	-
6	<ul style="list-style-type: none"> <li>Remove all test equipment except the DST.</li> <li>Connect any disconnected components, fuses, etc.</li> <li>Using the DST clear DTC information from the ECM.</li> <li>Turn the ignition OFF and wait 30 seconds.</li> <li>Start the engine and operate the vehicle to full operating temperature</li> <li>Observe the MIL</li> <li>Observe engine performance and drivability</li> <li>After operating the engine within the test parameters of DTC-1162 check for any stored codes.</li> </ul> <p>Does the engine operate normally with no stored codes?</p>		System OK	Go to OBD System Check

## **DTC 182- Gasoline Fuel Temperature Low (SPN 174:FMI 4)**

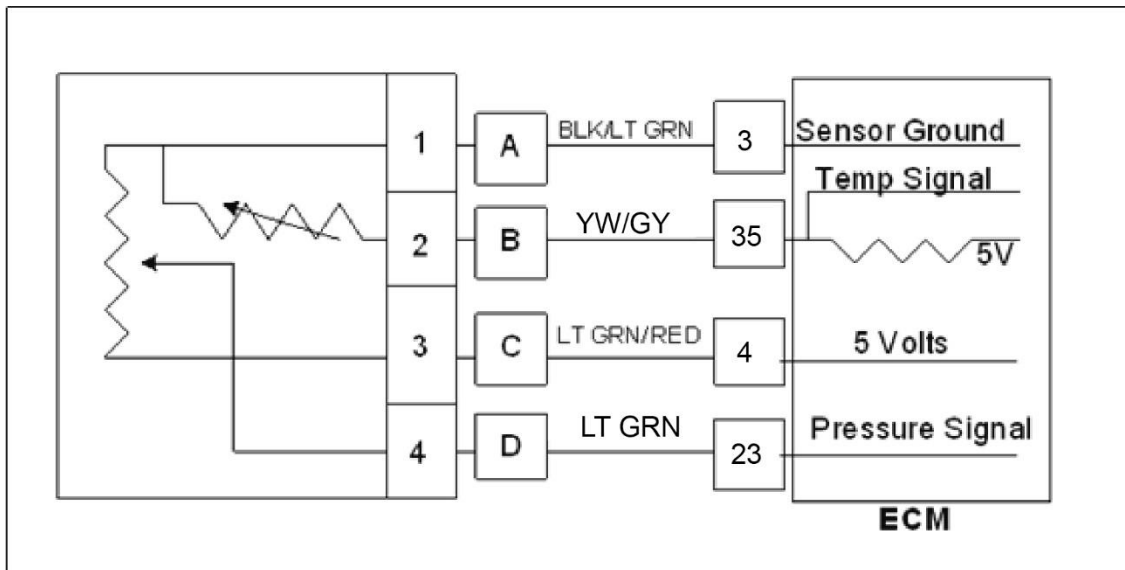

### **Conditions for Setting the DTC**

- Gasoline fuel temperature low
- Faulty fuel temp sensor
- Fuel temperature sensor voltage lower than .05v for 5 seconds or greater
- Fuel temperature is -35F or less for 5 seconds or greater
- MIL-On for active fault and for 2 seconds after active fault
- Adaptive Learn is disabled while this fault is active.

### **Circuit Description**

Note: The fuel pressure and temperature sensor is wired via Equipment Manufacturer supplied harness jumper. The terminals A, B, C, D & 19, 20, 48, 54 are engine wiring harness terminals at the fuel sensor interface connector C002 and the ECM header connector C001. You may need to consult additional wiring information supplied by the OEM. The gasoline fuel temperature sensor voltage is read at less than 0.05v. This indicates a low voltage fault from the sensor or circuit. This could also indicate a low fuel temperature reading. Inspect the fuel temperature for extreme cold.

## **DTC 183 - Gasoline Fuel Temperature High (SPN 174:FMI 3)**

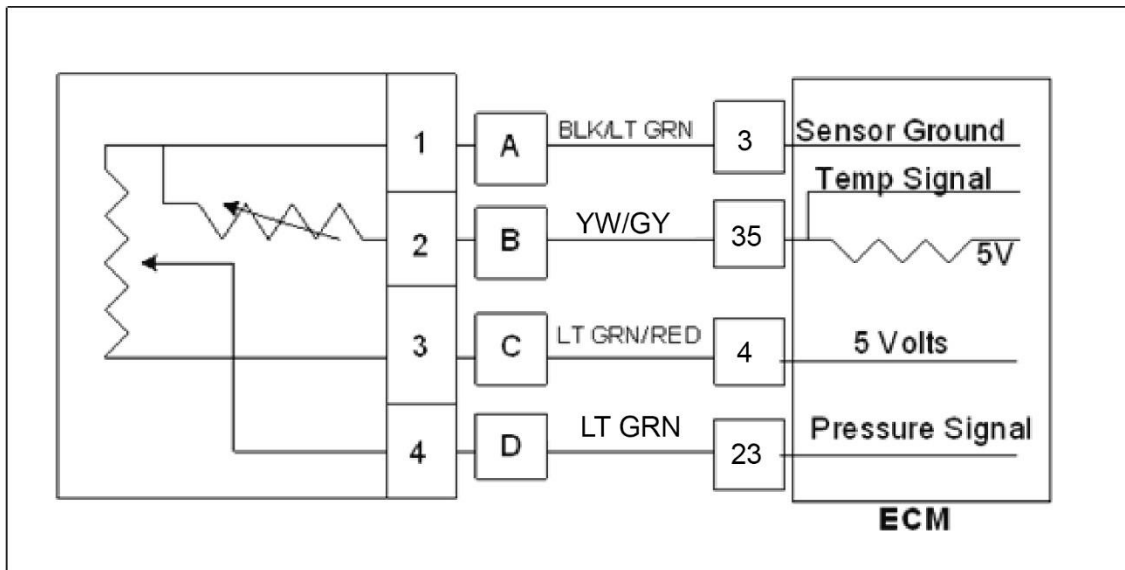

### **Conditions for Setting the DTC**

- Gasoline fuel temperature high
- Faulty fuel temp sensor
- Fuel temperature sensor voltage greater than 4.95v for 5 seconds or greater
- Fuel temperature is 130F or higher for 5 seconds or greater
- MIL-On for active fault and for 2 seconds after active fault
- Adaptive Learn is disabled while this fault is active.

### **Circuit Description**

Note: The fuel pressure and temperature sensor is wired via Equipment Manufacturer supplied harness jumper. The terminals A, B, C, D & 19, 20, 48, 54 are engine wiring harness terminals at the fuel sensor interface connector C002 and the ECM header connector C001. You may need to consult additional wiring information supplied by the OEM. The gasoline fuel temperature sensor voltage is read at less than 0.05v. This indicates a high voltage fault from the sensor or circuit. This could also indicate a high fuel temperature reading. Inspect the fuel temperature for extreme hot temperatures.

## **DTC 186- FT Gaseous Fuel Extremely Low (SPN 3468:FMI 1)**

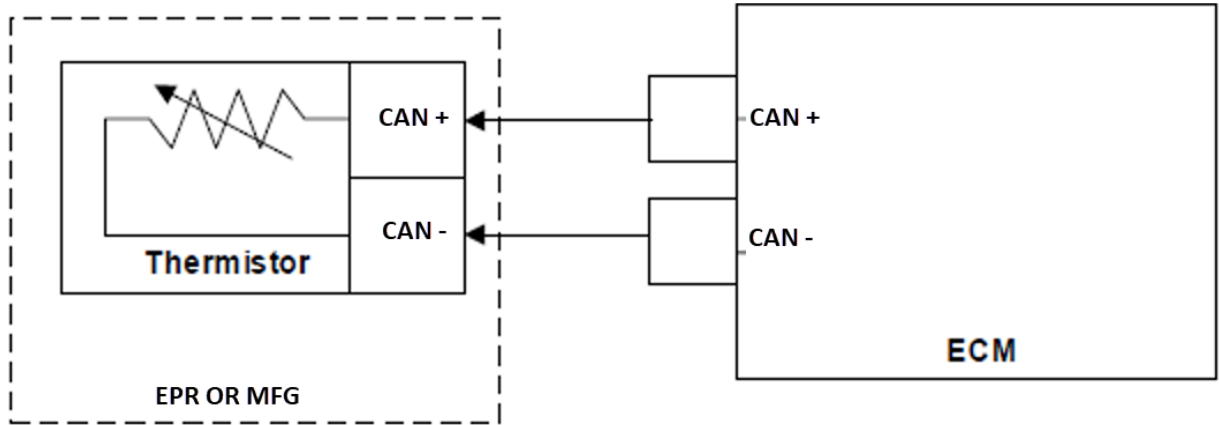

### **Conditions for Setting the DTC**

- Gaseous fuel temperature sensor
- Faulty fuel temp sensor
- Check Condition - Engine running / stopped checked (User defined in calibration)
- Fault Condition - Fuel temperature < -40°F
- MIL-On for active fault and for 10 seconds

### **Circuit Description**

The Fuel Temperature sensor is a thermistor (temperature sensitive resistor) that is integrated within the DEPR or MFG. The temperature data is transmitted to the ECM via the J1939 CAN+ and CAN- communication network. It is used to calculate the fuel mass flow.

This fault is not user modifiable. It is always enabled and is intended to protect the CFV from extremely low fuel temperatures by load limiting the system when the FT falls below the target temperature given in the fault conditions.

## **DTC 187 - Fuel Temperature Gaseous Low (SPN 3468 FMI 4)**

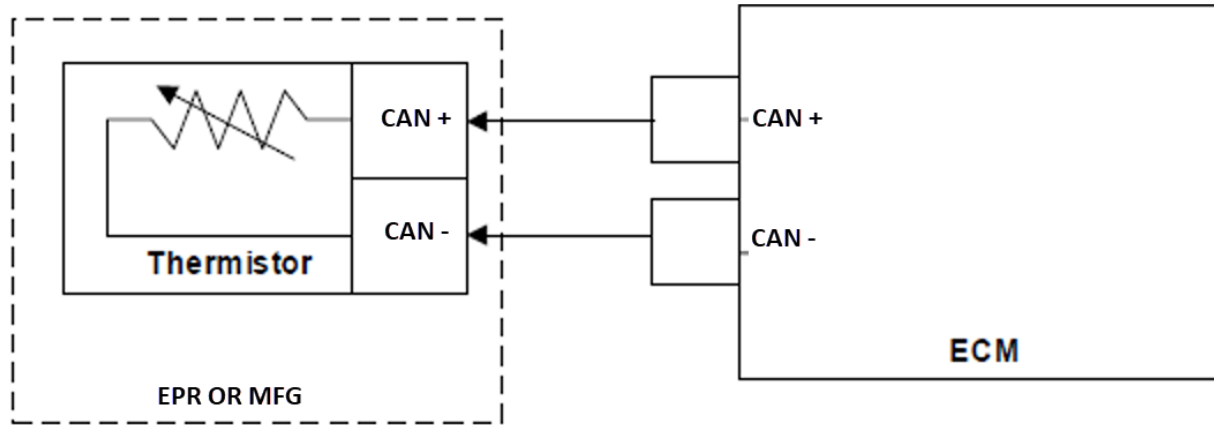

### **Conditions for setting DTC**

- Key on, Engine on
- Fault Conditions: FT voltage less than normal operating voltage or fuel temperature less than normal operating temperature.

### **Fault Description**

The Fuel Temperature sensor is a thermistor (temperature sensitive resistor) that is integrated within the DEPR or MFG. The temperature data is transmitted to the ECM via the J1939 CAN+ and CAN- communication network. It is used to calculate the fuel mass flow.

This fault is not user modifiable. It is always enabled and is intended to protect the CFV from extremely low fuel temperatures by load limiting the system when the FT falls below the target temperature given in the fault conditions.



## DTC 187 - Fuel Temperature Gaseous Low

Step	Action	Value(s)	Yes	No
1	Did you perform the On-Board (OBD) System Check?	-	Go to Step (2)	Go to OBD System Check Section
2	Key ON, Engine Running System Mode = "Running"	Does DST display FT a voltage less than the limit defined in calibration?	Go to Step (3)	Go to Step (4)
3	Key OFF Key On, Engine Off System Mode = "Stopped" Wait for fuel pump to stop running Disconnect FT sensor from harness	Does DST display FT voltage of 0.1 or less?	Go to Step (5)	Go to Step (6)
4	Intermittent Problem Condition is operating condition dependent			
5	Faulty FT sensor			
6	Sensor signal circuit shorted to ground, check wire harness for ground short Faulty ECM			

## DTC 188 - FT Gaseous Fuel High (SPN 520240 FMI 3)

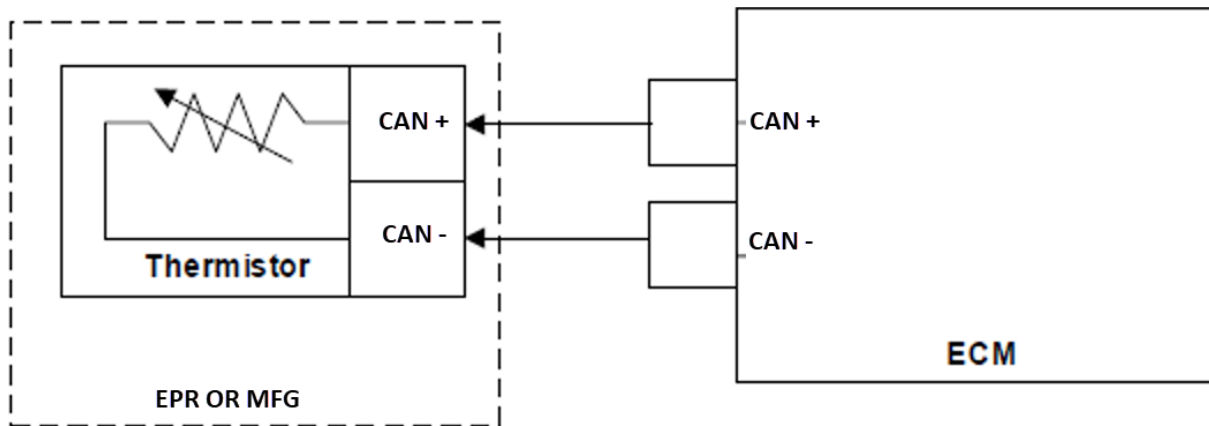

### Conditions for Setting the DTC

- Check Condition: Key-On, Engine Running
- Fault Conditions: FT voltage greater than 4.95v or fuel temp is greater than 250F.
- MIL: ON during active fault

### Fault Description

The Fuel Temperature sensor is a thermistor (temperature sensitive resistor) integrated into the EPR fuel outlet OR MFG. It is used to monitor the gaseous fuel temperature exiting the EPR/MFG to be used as an input in a fuel temperature estimation of the temperature entering the gaseous mixer.

This information is used to calculate a real-time fuel pressure correction in order to reduce fueling errors. The DPR or MFG sends the fuel temperature information to the ECM via the CAN J1939 communication circuit between the EPR/MFG and ECM

This fault code is set when the ECM receives data indicating that the voltage associated with the gaseous fuel temperature sensor is greater than 4.95 volts or when the fuel temperature itself exceeds 250 degrees Fahrenheit. The ECM is programmed to interpret these conditions as potential issues with the gaseous fuel system, and it generates a fault code accordingly.

## DTC 188 - FT Gaseous Fuel High

Step	Action	Value(s)	Yes	No
1	Did you perform the On-Board (OBD) System Check?	-	Go to Step (2)	Go to OBD System Check Section
2	Key ON, Engine OFF System Mode = "Stopped"  In 4G Display FAULTS Page, monitor Fuel Temperature.  Is the temperature greater than the diagnostic threshold?	>250F	Go to Step (3)	Go to Step (4)
3	Measure your fuel temp with an infrared gun or temperature probe,  Is the fuel temp greater than 250F?	>250F	Determine cause of high fuel temp and resolve	Replace MFG or EPR
4	Start engine and monitor fuel temp as engine is running.  Is the fuel temp greater than 250F?	>250F	Determine cause of high fuel temp and resolve	

## **DTC 217- ECT Higher Than Expected (SPN 110:FMI 0)**

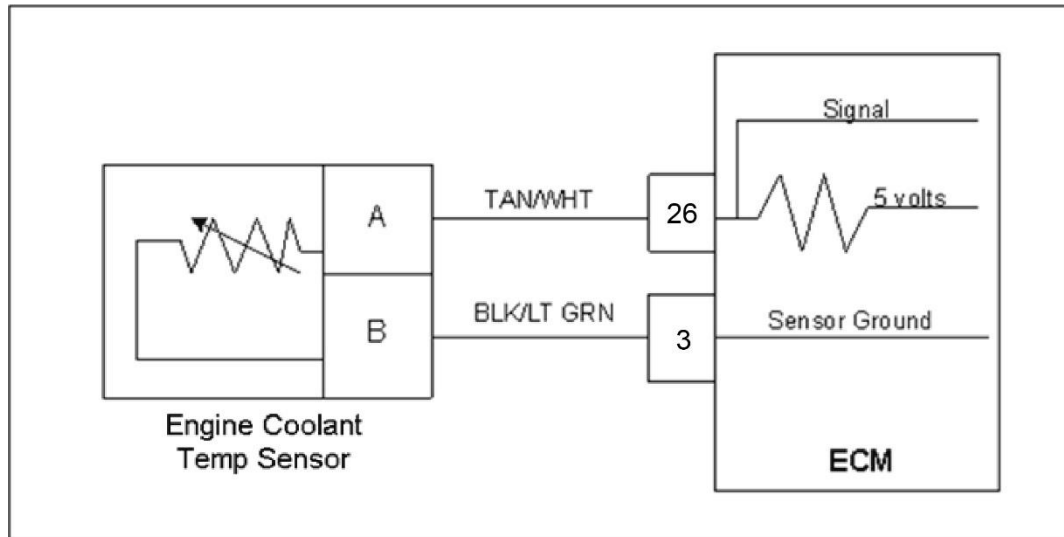

### **Conditions for Setting the DTC**

- Engine Coolant Temperature
- Check Condition-Engine Running
- Fault Condition-Engine Coolant Temperature reading or estimate greater than fault code diagnostic setting criteria for greater than 5 seconds while engine is above 700 rpms
- MIL-On
- Engine will derate to 1,400 rpms

### **Circuit Description**

The ECT (Engine Coolant Temperature) sensor is a temperature sensitive resistor located in the engine coolant sensor that is located in the coolant passage. The ECT is used for engine airflow calculation, fuel enrichment, and ignition timing control and to enable certain other temperature dependent operations. This code set is designed to help prevent engine damage from overheating. The ECM provides a voltage divider circuit so when the sensor reading is cool the sensor reads higher voltage, and lower when warm. This fault will set when the coolant exceeds the diagnostic threshold for more than 5 seconds. Engine shutdown will occur if this code occurs.

## DTC 219 – Max Govern Speed Override (SPN 515:FMI 15)

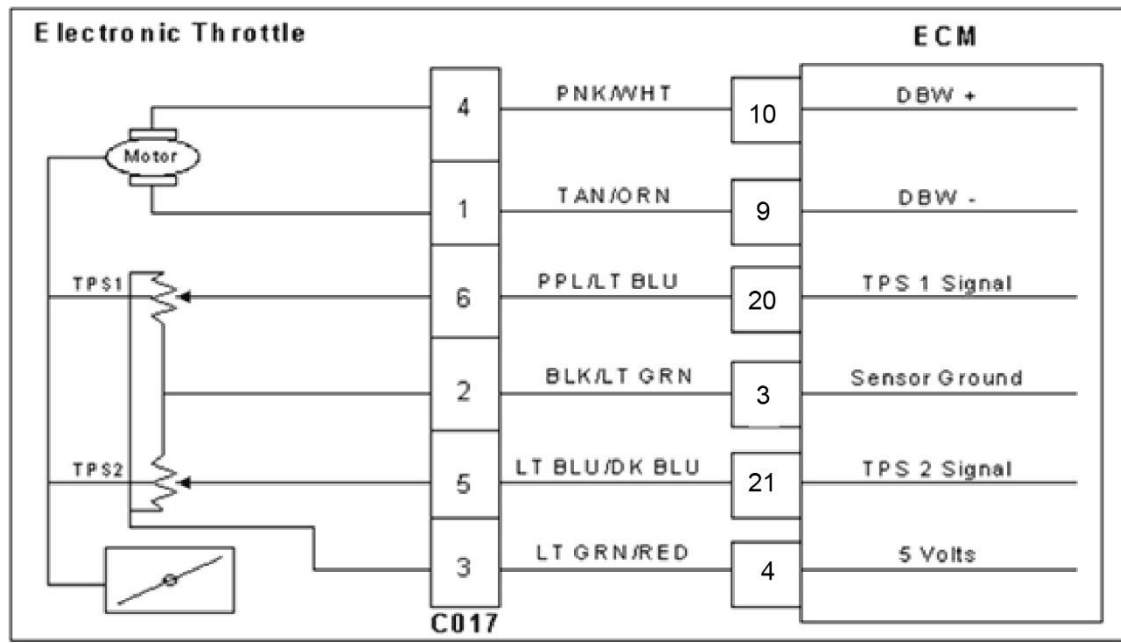

### Conditions for Setting the DTC

- Max Govern Speed Override
- Check Condition-Engine Running
- Fault Condition-Engine rpm greater than 2,850
- Fault condition active for 2 or more seconds
- MIL-ON during active fault

### Circuit description

This fault will set anytime the engine rpm exceeds 2,850 for longer than 2 seconds. The MIL command is ON during this active fault.

### Diagnostic Aid

Check for other stored DTC codes before using the following DTC chart for this code set. Always diagnose and repair any existing codes starting with the lowest numerical code first.

Step	Action	Value(s)	Yes	No
1	Did you perform the On-Board (OBD) System Check?	-	Go to Step (2)	Go to OBD System Check Section
2	<ul style="list-style-type: none"> <li>Key ON, Engine OFF</li> <li>DST connected</li> </ul> Are any other DTC codes present with DTC 219?		Go to Step (3)	Go to Step (4)
3	<ul style="list-style-type: none"> <li>Diagnose and repair any other DTC codes stored before proceeding with this chart.</li> </ul> Have any other DTC codes been diagnosed and repaired?		Go to Step (4)	-
4	<ul style="list-style-type: none"> <li>Check the service part number on the ECM to ensure the correct calibration is in use</li> </ul> Is the Service Part Number Correct?		Go to Step (6)	Go to Step 5
5	<ul style="list-style-type: none"> <li>Replace ECM with correct service part number</li> </ul> Is the replacement complete?		Go to Step (9)	-
6	<ul style="list-style-type: none"> <li>Check the mechanical operation of the throttles</li> </ul> the mechanical operation of the throttle, OK?		Go to Step (8)	Go to Step (7)
7	<ul style="list-style-type: none"> <li>Correct mechanical operation of the throttle.</li> </ul> Refer to Engine & Component section Has the mechanical operation of the throttle been corrected?		Go to Step (9)	-
8	<ul style="list-style-type: none"> <li>Check engine for large manifold vacuum leaks.</li> </ul> Refer to Symptom Diagnostic section Did you find and correct the vacuum leak?		Go to Step (9)	Go to OBD System Check Section
9	<ul style="list-style-type: none"> <li>Remove all test equipment except the DST.</li> <li>Connect any disconnected components, fuses, etc.</li> <li>Using the DST clear DTC information from the ECM.</li> <li>Turn the ignition OFF and wait 30 seconds.</li> <li>Start the engine and operate the vehicle to full operating temperature</li> <li>Observe the MIL</li> <li>Observe engine performance and drivability</li> <li>After operating the engine within the test parameters of DTC-219 check for any stored codes.</li> </ul> Does the engine operate normally with no stored codes?		System OK	Go to OBD System Check

## DTC 221 – TPS 1 Higher Than TPS 2 (SPN 51:FMI 0)

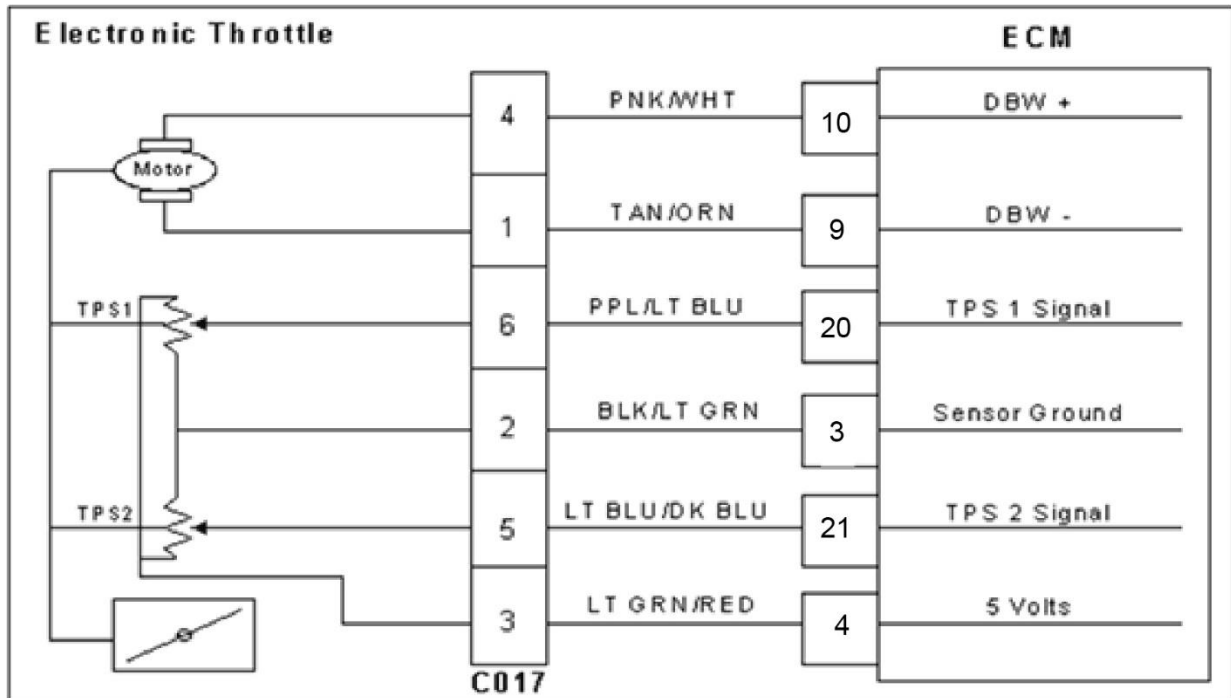

### Conditions for Setting the DTC

- Throttle Position Sensor 1 & 2
- Check Condition-Key ON
- Fault Condition-TPS 1 20% higher than TPS2
- MIL-ON for remainder of key on cycle
- Engine shutdown

### Circuit Description

Dual throttle Position Sensors are used within the throttle that use variable resistors to determine signal voltage based on throttle plate position. TPS 1 will read lower voltage when closed and TPS 2 will read higher voltage when closed. The TPS 1 and TPS 2 percentages are calculated from these voltages. Although the voltages are different, the calculated values for the throttle position percentages should be very close to the same. The TPS values are used by the ECM to determine if the throttle is opening as commanded. The TPS is not serviceable and in the event of a failure the electronic throttle assembly must be replaced. This fault will set if TPS 1 is 20% (or more) higher than TPS 2. At this point the throttle is considered to be out of specification, or there is a problem with the TPS signal circuit. The MIL command is ON and the engine will shutdown.

Step	Action	Value(s)	Yes	No
1	Did you perform the On-Board (OBD) System Check?	-	Go to Step (2)	Go to OBD System Check Section
2	<ul style="list-style-type: none"> <li>Key ON, Engine OFF</li> <li>DST (Diagnostic Scan Tool) connected in System Data Mode</li> </ul> Does the DST display more than a 20% difference between TPS 1 and TPS 2?		Go to Step (3)	Intermittent problem Go to Intermittent section
3	<ul style="list-style-type: none"> <li>Key OFF</li> <li>Disconnect electronic throttle connector C017</li> <li>Key ON</li> <li>Change DST mode to DBW (drive by wire) test mode</li> </ul> Is the voltage for TPS 1 less than 0.1 volts?		Go to Step (5)	Go to Step (4)
4	<ul style="list-style-type: none"> <li>Key OFF</li> <li>Disconnect ECM wiring harness connector C001</li> <li>Key ON</li> <li>Using a DVOM check for voltage between ECM connector TPS 1 signal pin 20 and engine ground</li> </ul> Do you have voltage?		Repair the TPS 1 circuit shorted to voltage as necessary. Refer to Wiring Repairs in Engine Electrical.	Go to Step (9)
5	<ul style="list-style-type: none"> <li>Jump TPS 1 signal pin 6 to the 5-volt reference pin 3 at connector C017</li> </ul> Does DST display TPS 1 voltage over 4.900volts?		Go to Step (6)	Go to Step (8)
6	<ul style="list-style-type: none"> <li>Inspect wire terminals at throttle connector for damage corrosion or contamination</li> </ul> Any problems found?		Repair the circuit as necessary. Refer to Wiring Repairs in Engine Electrical.	Go to Step (7)
7	<ul style="list-style-type: none"> <li>Replace the electronic Throttles</li> </ul> the replacement complete?		Go to Step (12)	-
8	<ul style="list-style-type: none"> <li>Key OFF</li> <li>Disconnect ECM wire harness connector C001</li> <li>Using a DVOM check for continuity between throttle connector TPS 1 signal pin 21 and ECM connector TPS 1 signal pin 5</li> </ul> Do you have continuity between them?		Go to Step (9)	Repair the open circuit as necessary. Refer to Wiring Repairs in Engine Electrical.



Step	Action	Value(s)	Yes	No
9	<ul style="list-style-type: none"> <li>Using a DVOM check for continuity between throttle connector signal ground pin 2 and ECM connector signal ground pin 3</li> </ul> Do you have continuity between them?		Go to Step (10)	Repair the open circuit as necessary. Refer to Wiring Repairs in Engine Electrical.
10	<ul style="list-style-type: none"> <li>Inspect ECM connector terminals for damage corrosion or contamination.</li> </ul> Any problems found?		Repair the circuit as necessary. Refer to Wiring Repairs in Engine Electrical	Go to Step (11)
11	<ul style="list-style-type: none"> <li>Replace ECM</li> </ul> Is the replacement complete?		Go to Step (12)	-
12	<ul style="list-style-type: none"> <li>Remove all test equipment except the DST.</li> <li>Connect any disconnected components, fuses, etc.</li> <li>Using the DST clear DTC information from the ECM.</li> <li>Turn the ignition OFF and wait 30 seconds.</li> <li>Start the engine and operate the vehicle to full operating temperature</li> <li>Observe the MIL</li> <li>Observe engine performance and drivability</li> <li>After operating the engine within the test parameters of DTC-221 check for any stored codes.</li> </ul> Does the engine operate normally with no stored codes?		System OK	Go to OBD System Check

## DTC 222-TPS 2 Signal Voltage Low (SPN 3673:FMI 4)

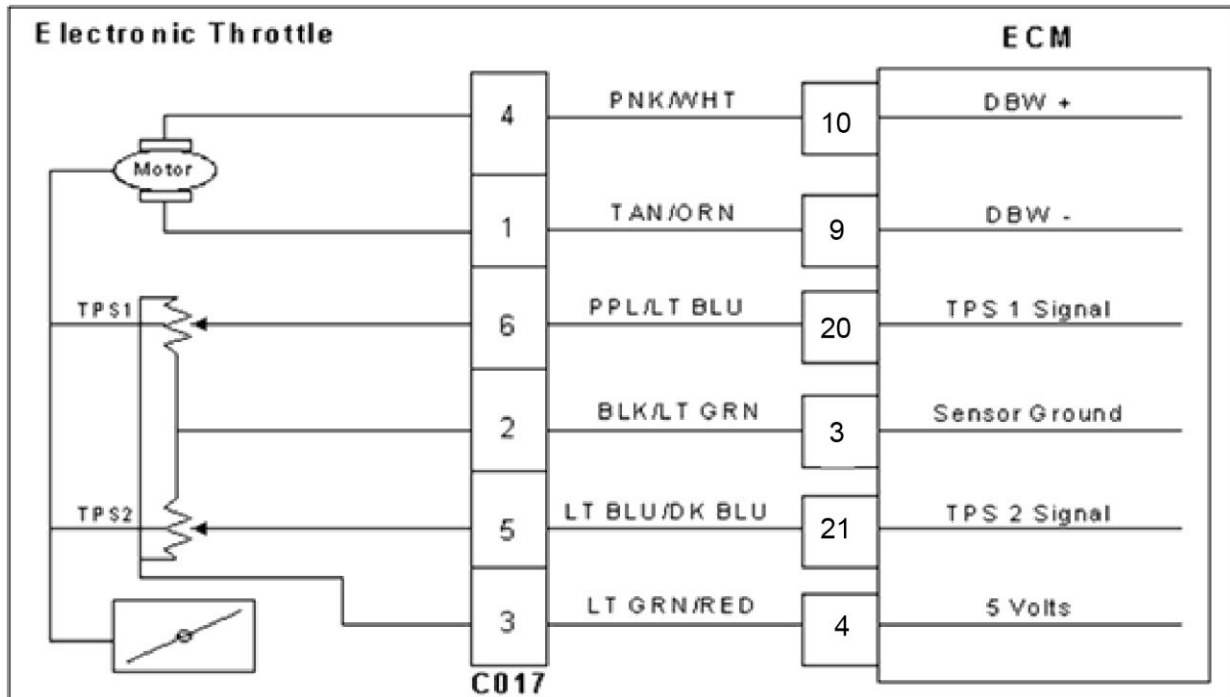

### Conditions for Setting the DTC

- Throttle Position Sensor 2
- Check Condition-Cranking or Running
- Fault Condition-TPS 2 sensor voltage less than 0.200 volts
- MIL-ON during active fault
- Engine will Shutdown

### Circuit Description

Dual throttle Position Sensors are used within the throttle that use variable resistors to determine signal voltage based on throttle plate position. TPS1 will read lower voltage when closed and TPS2 will read higher voltage when closed. The TPS1 and TPS2 percentages are calculated from these voltages. Although the voltages are different, the calculated values for the throttle position percentages should be very close to the same. The TPS values are used by the ECM to determine if the throttle is opening as commanded. The TPS is not serviceable and in the event of a failure the electronic throttle assembly must be replaced.

This fault will set if the TPS 2 voltage is less than 0.200 volts. The MIL command is ON and engine will shutdown.

Step	Action	Value(s)	Yes	No
1	Did you perform the On-Board (OBD) System Check?	-	Go to Step (2)	Go to OBD System Check Section
2	<ul style="list-style-type: none"> <li>Key ON, Engine OFF</li> <li>DST (Diagnostic Scan Tool) connected in DBW (Drive by Wire) throttle test mode</li> </ul> Does the DST display TPS 2 voltage of 0.200volts or less with the throttle closed?		Go to Step (4)	Go to Step (3)
3	<ul style="list-style-type: none"> <li>Slowly depress Foot Pedal while observing TPS 2 voltage</li> </ul> Does TPS 2 voltage ever fall below 0.200 volts?		Go to Step (4)	Intermittent problem Go to Intermittent section
4	<ul style="list-style-type: none"> <li>Key OFF</li> <li>Disconnect electronic throttle connector C017</li> <li>Jumper the 5-volt reference circuit pin 3 and TPS 2 signal circuit pin 5 together at the throttle connector</li> <li>Key ON</li> </ul> Does DST display TPS 2 voltage of 4.0 volts or greater?		Go to Step (7)	Go to Step (5)
5	<ul style="list-style-type: none"> <li>Key OFF</li> <li>Disconnect ECM wire harness connector C001</li> <li>Using a DVOM check continuity between TPS 2 connector signal pin 5 and ECM connector TPS 2 Signal pin 6</li> </ul> Do have continuity between them?		Go to Step (6)	Repair the circuit as necessary. Refer to Wiring Repairs in Engine Electrical.
6	<ul style="list-style-type: none"> <li>Replace ECM</li> </ul> Is the replacement complete?		Go to Step (9)	-
7	<ul style="list-style-type: none"> <li>Inspect the electronic throttle wire harness connector terminals for damage, corrosion or contamination</li> </ul> Did you find a problem?		Repair the circuit as necessary. Refer to Wiring Repairs in Engine Electrical.	Go to Step (8)
8	<ul style="list-style-type: none"> <li>Replace the electronic throttle</li> </ul> Is the replacement complete?		Go to Step (9)	-

Step	Action	Value(s)	Yes	No
9	<ul style="list-style-type: none"> <li>• Remove all test equipment except the DST.</li> <li>• Connect any disconnected components, fuses, etc.</li> <li>• Using the DST clear DTC information from the ECM.</li> <li>• Turn the ignition OFF and wait 30 seconds.</li> <li>• Start the engine and operate the vehicle to full operating temperature</li> <li>• Observe the MIL</li> <li>• Observe engine performance and drivability</li> <li>• After operating the engine within the test parameters of DTC-222 check for any stored codes.</li> </ul> <p>Does the engine operate normally with no stored codes?</p>		System OK	Go to OBD System Check

## DTC 223-TPS 2 Signal Voltage High (SPN 3673:FMI 3)

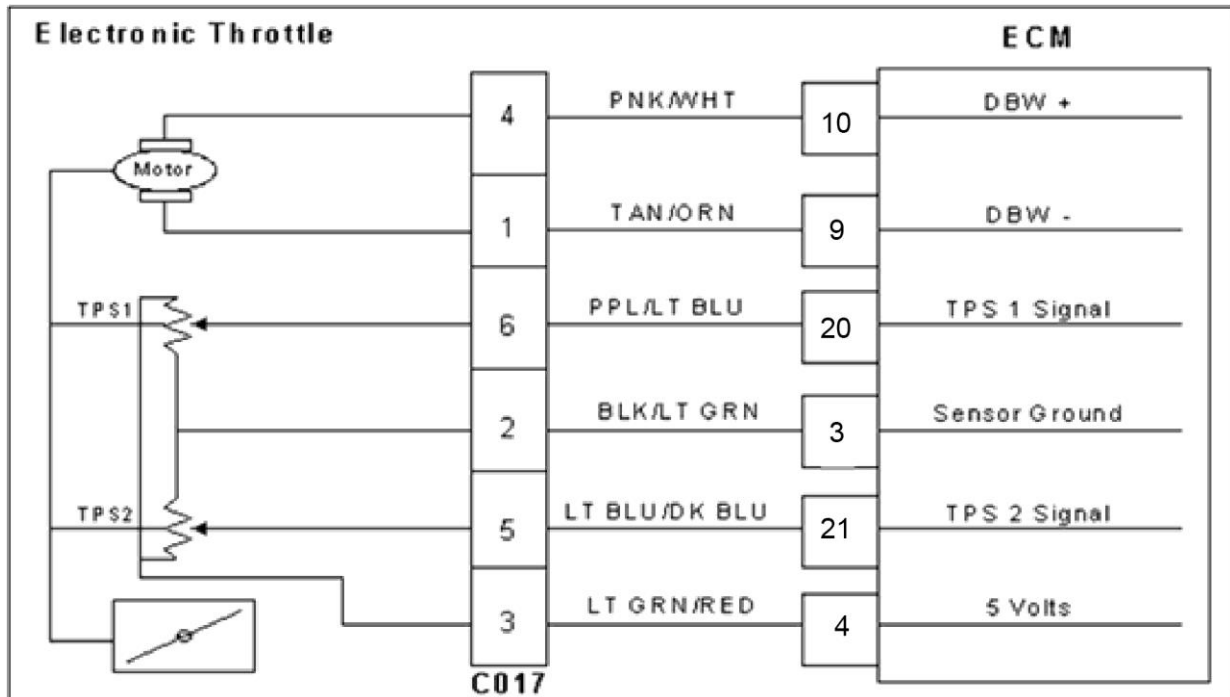

### Conditions for Setting the DTC

- Throttle Position Sensor 2
- Check Condition-Cranking or Running
- Fault Condition-TPS 2 sensor exceeds 4.800 volts
- MIL-ON during active fault
- Engine will shutdown

### Circuit Description

Dual throttle Position Sensors are used within the throttle that use variable resistors to determine signal voltage based on throttle plate position. TPS1 will read lower voltage when closed and TPS2 will read higher voltage when closed. The TPS1 and TPS2 percentages are calculated from these voltages. Although the voltages are different, the calculated values for the throttle position percentages should be very close to the same. The TPS values are used by the ECM to determine if the throttle is opening as commanded. The TPS is not serviceable and in the event of a failure the electronic throttle assembly must be replaced. This fault will set if the TPS 2 voltage is greater than 4.800 volts. The MIL command is ON and the engine will shut down.

Step	Action	Value(s)	Yes	No
1	Did you perform the On-Board (OBD) System Check?	-	Go to Step (2)	Go to OBD System Check Section
2	<ul style="list-style-type: none"> <li>Key ON, Engine OFF</li> <li>DST (Diagnostic Scan Tool) connected inDBW (Drive by Wire) throttle test mode</li> </ul> Does the DST display TPS 2 voltage of 4.800volts or greater with the throttle closed?		Go to Step (4)	Go to Step (3)
3	<ul style="list-style-type: none"> <li>Slowly depress Foot Pedal while observingTPS 2 voltage</li> </ul> Does TPS 2 voltage ever exceed 4.800 volts?		Go to Step (4)	Intermittent problem Go to Intermittent section
4	<ul style="list-style-type: none"> <li>Key OFF</li> <li>Disconnect electronic throttle connector C017</li> <li>Key ON</li> </ul> Does DST display TPS 2 voltage less than 0.2volts?		Go to Step (7)	Go to Step (5)
5	<ul style="list-style-type: none"> <li>Key OFF</li> <li>Disconnect ECM wire harness connector C001</li> <li>Key ON</li> <li>Using a DVOM check for voltage between electronic throttle connector TPS 2 signal pin5 and engine ground</li> </ul> Do you have voltage?		Repair the circuit as necessary. Referto Wiring Repairs in Engine Electrical.	Go to Step (6)
6	<ul style="list-style-type: none"> <li>Replace ECM</li> </ul> Is the replacement complete?		Go to Step (11)	-
7	<ul style="list-style-type: none"> <li>Probe sensor ground circuit at the ECM side of the wire harness pin 3 with a test light connected to battery voltage</li> </ul> Does the test light come on?		Go to Step (8)	Go to Step (10)
8	<ul style="list-style-type: none"> <li>Inspect the electronic throttle wire harness connector and terminals for damage, corrosion or contamination</li> </ul> Did you find a problem?		Repair the circuit as necessary. Referto Wiring Repairs in Engine Electrical.	Go to Step (9)
9	<ul style="list-style-type: none"> <li>Replace electronic throttles</li> </ul> the replacement complete?		Go to Step (11)	-
10	<ul style="list-style-type: none"> <li>Key OFF</li> <li>Disconnect ECM connector C001</li> <li>Using a DVOM check for continuity between throttle connector C017 sensor ground pin 2 and ECM connector sensor ground pin 3</li> </ul> Do have continuity between them?		Go to Step (6)	Repair the circuit as necessary. Refer to Wiring Repairs in Engine Electrical.

Step	Action	Value(s)	Yes	No
11	<ul style="list-style-type: none"> <li>• Remove all test equipment except the DST.</li> <li>• Connect any disconnected components, fuses, etc.</li> <li>• Using the DST clear DTC information from the ECM.</li> <li>• Turn the ignition OFF and wait 30 seconds.</li> <li>• Start the engine and operate the vehicle to full operating temperature</li> <li>• Observe the MIL</li> <li>• Observe engine performance and drivability</li> <li>• After operating the engine within the test parameters of DTC-223 check for any stored codes.</li> </ul> <p>Does the engine operate normally with no stored codes?</p>		System OK	Go to OBD System Check

## DTC 236 - TIP/TOP Active

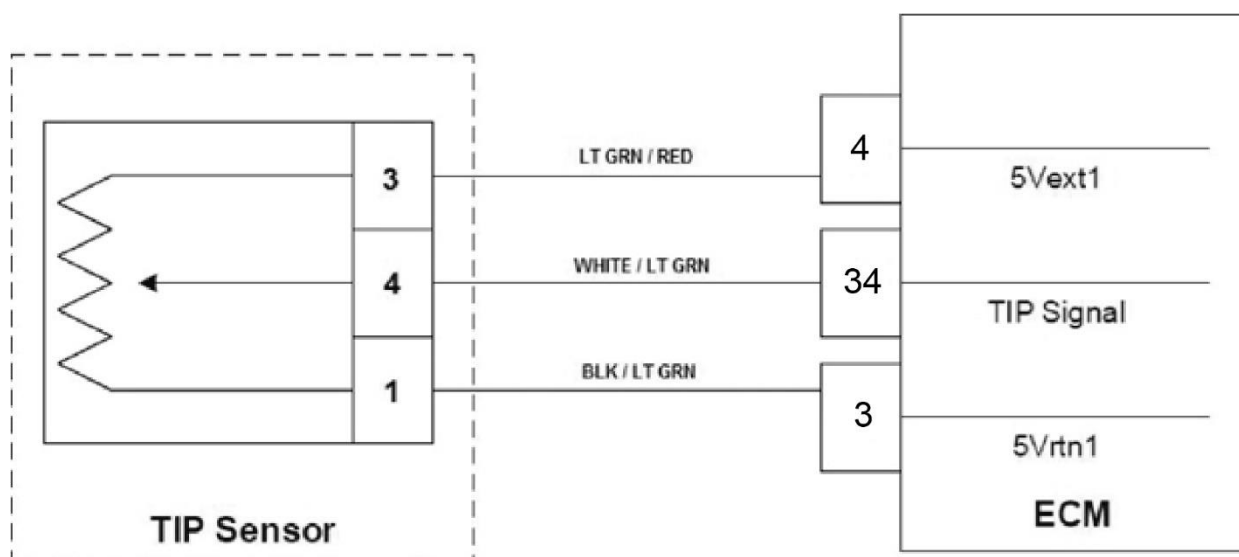

### Conditions for Setting the DTC

- Check Condition: Key On, Engine Running
- Fault Condition: TIP < 16 psia and MAP > 18 psia
- MIL on
- Adaptive disabled

### Fault Description

The engine uses a throttle inlet pressure (TIP) sensor upstream of the throttle valve to monitor incoming throttle pressure. The TIP should always be higher than the MAP. If MAP is ever at 18 psia or higher and TIP is reading at less than 16 psia, a TIP/TOP active fault is logged.

### Diagnosing the Fault

Check to make sure the wiring for the TIP and MAP sensors is not reversed. The two sensors are identical, and they are close enough to each other that it is possible to swap the connectors. The TIP sensor, located on the charge air piping, should have three wires at the connector while the MAP sensor, located on the throttle body adapter on the intake manifold, should have four wires at the connector. If the wiring for the sensors is correct, check to ensure the sensor is properly installed in the CAC piping. It should be held in place with a retaining bolt. Ensure it is fully installed into the pipe and the bolt is tight.

If the installation is correct, remove the sensor and inspect for damage. Replace the sensor with a known good part and test again.



## DTC 237 - TIP/TOP Low Voltage

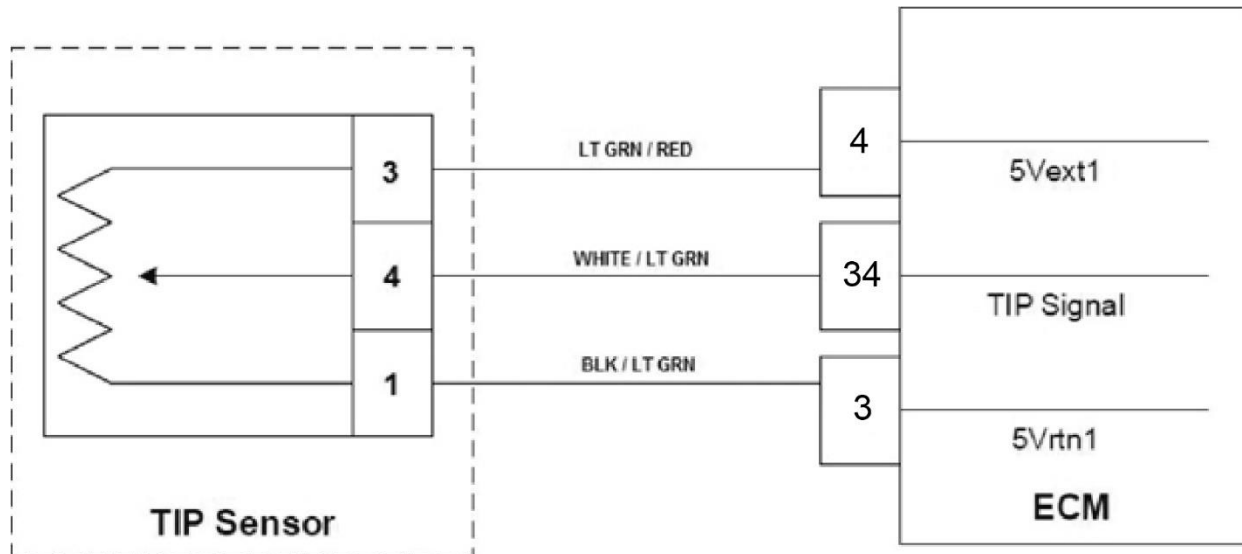

### Conditions for Setting the DTC

- Throttle Inlet Pressure
- Check Condition: Key On, Engine Off
- Fault Condition: TIP voltage less than 0.2V
- MIL on
- Adaptive disabled

### Fault Description

The engine uses a throttle inlet pressure (TIP) sensor upstream of the throttle valve to monitor incoming throttle pressure. This fault will set when the TIP sensor voltage feedback is sensed as lower than the sensor should normally produce as set in the diagnostic calibration.

### Diagnosing the Fault

In many cases, this condition is caused by the TIP sensor being disconnected from the engine harness, an open-circuit or short-to-ground of the TIP sensor circuit in the wire harness, a loss of sensor reference voltage, or a failure of the sensor.

## DTC 237 - TIP/TOP Low Voltage

Step	Action	Value(s)	Yes	No
1	Did you perform the On-Board (OBD) System Check?	-	Go to Step (2)	Go to OBD System Check Section
2	Key ON, Engine Running System Mode = "Running"	Does DST display TIP voltage less than the limit defined in calibration with the engine running??	Go to Step (3)	Go to Step (4)
3	Key On, Engine Off System Mode ="Stopped"		Go to Step (5)	
4	Intermittent Problem			
5	If DTC 642 or 643 are present, troubleshoot those first. Using a DMM, measure the voltage potential across 5Vref1 and 5Vrtn1 at connector.	Does DMM indicate a voltage >4.7 VDC?	Go to Step (6)	Go to Step (7)
6	Jumper the TIP circuit to Vref (5 VDC) in connector on harness.	Does DST display TIP voltage of 4.7 VDC or greater?	Go to Step (8)	Go to Step (9)
7	Faulty harness (check 5Vref1 and 5Vrtn1 connections) Faulty ECM (5Vref power supply).			
8	Poor connection at sensor Faulty TIP sensor			

Step	Action	Value(s)	Yes	No
9	<p>Key Off</p> <p>Disconnect wire harness header from ECM</p> <p>Carefully remove yellow lock from header at device output terminal</p> <p><b>CAREFULLY</b> check resistance between TPS2 input at ECM header and signal at device.  <b>NOTE: DO NOT INSERT</b> probe or object into terminals as this will cause the terminal to spread and may no longer make contact with ECM pins. Spread pins will void warranty! Probe on the side of terminal.</p>	Is the resistance <5 ohms?	Go to Step (10)	Go to Step (11)
10	<p>Reconnect header to ECM</p> <p>Key On, Engine Off</p> <p>System Mode="Stopped"</p> <p>Probe TIP signal circuit with a test light connected to battery voltage</p>	Does DST display TIP voltage of 4.0 VDC or greater?	Go to Step (12)	Go to Step (13)
11	Faulty Harness			
12	<p>Faulty ECM connection</p> <p>Faulty ECM (analog input circuit)</p>			
13	<p>TIP signal shorted to ground</p> <p>Faulty ECM connection</p> <p>Faulty ECM (analog input circuit)</p>			

## DTC 238 - TIP/TOP High Voltage

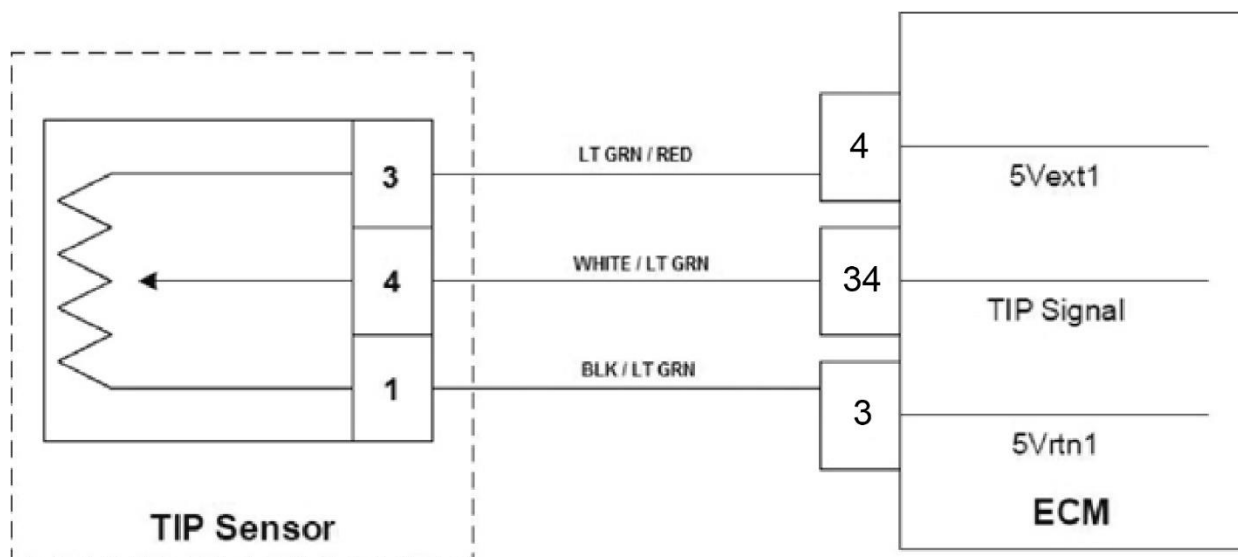

### Conditions for Setting the DTC

- Throttle Inlet Pressure
- Check Condition: Key On, Engine Off
- Fault Condition: TIP voltage greater than 4.8V
- MIL on
- Adaptive disabled

### Fault Description

The engine uses a throttle inlet pressure (TIP) sensor upstream of the throttle valve to monitor incoming throttle pressure. This fault will set when the TIP sensor voltage feedback is sensed as higher than the sensor should normally produce as set in the diagnostic calibration.

### Diagnosing the Fault

In many cases, this condition is caused by the TIP circuit being shorted to a voltage source or a failure of the sensor.

## DTC 238 - TIP/TOP High Voltage

Step	Action	Value(s)	Yes	No
1	Did you perform the On-Board (OBD) System Check?	-	Go to Step (2)	Go to OBD System Check Section
2	Key ON, Engine On System Mode = "Running"	Does DST display TIP pressure greater than that defined in the diagnostic calibration with the engine idling?	Go to Step (3)	Go to Step (4)
3	Key Off Disconnect TIP sensor from harness Key On, Engine off System Mode = "Stopped"	Does DST display TIP voltage <0.100 VDC?	Go to Step (5)	Go to Step (6)
4	Intermittent Problem			
5	Probe sensor ground circuit with test light connected to battery voltage	Does test light come on?	Go to Step (7)	Go to Step (8)
6	TIP signal circuit shorted to voltage Faulty sensor Faulty ECM			
7	Faulty TIP sensor Faulty ECM connector			
8	Open sensor ground circuit Faulty ECM			

## DTC 261-Injector Driver 1 (CYL 1) Open or Short to Ground (SPN 651:FMI 5)

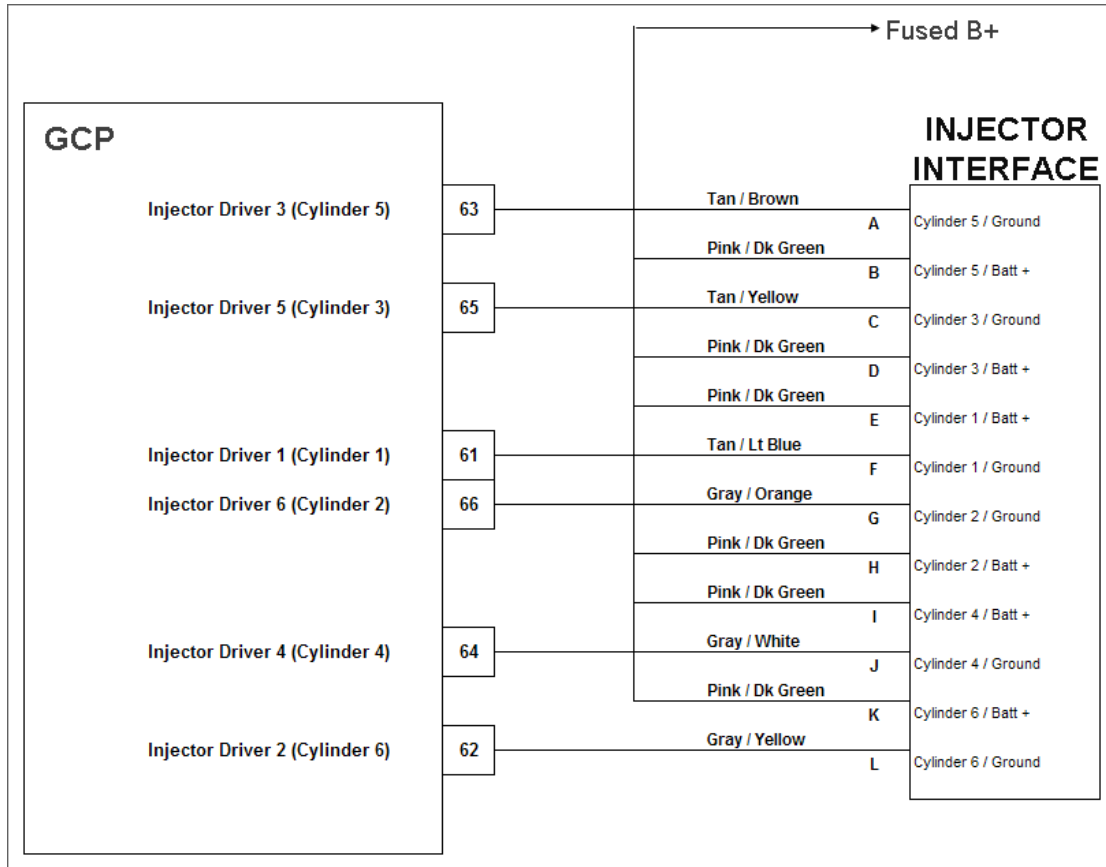

### Conditions for Setting the DTC

- Injector is in the Off State
- Low side voltage is less than 4.0 volts
- Battery voltage is above 9.0 volts
- MIL Light turned on
- Closed Loop is disabled while this fault is active
- Adaptive Learn is disabled while this fault is active.

### Circuit Description

The fuel injectors turn on when the ECM provides a ground circuit to the injector. Battery positive is constantly provided through the ignition fuse and the Pink / DK Green wire. Each Injector has a ground side driver assigned to it inside the ECM. The driver number does not match up with the mating cylinder number in each case. The driver is assigned in numerical order according to the engine firing order (4.3L = 1, 6, 5, 4, 3, 2). The ECM is monitoring the low side voltage internally in the ECM. This code will set if it sees a low voltage on the low side during an “injector off” state. This indicates the injector is open or there is a short to ground in the circuit.

The technician should check the wiring and the injector resistance. If the resistance is out of specification or you get an infinite reading on the DVOM you should replace the injector. If there is a short to ground in the wiring circuit you should repair the faulty circuit in accordance with the recommended wire repair instructions provided in this manual.

## DTC 264-Injector Driver 2 (CYL 6) Open or Short to Ground (SPN 652:FMI 5)

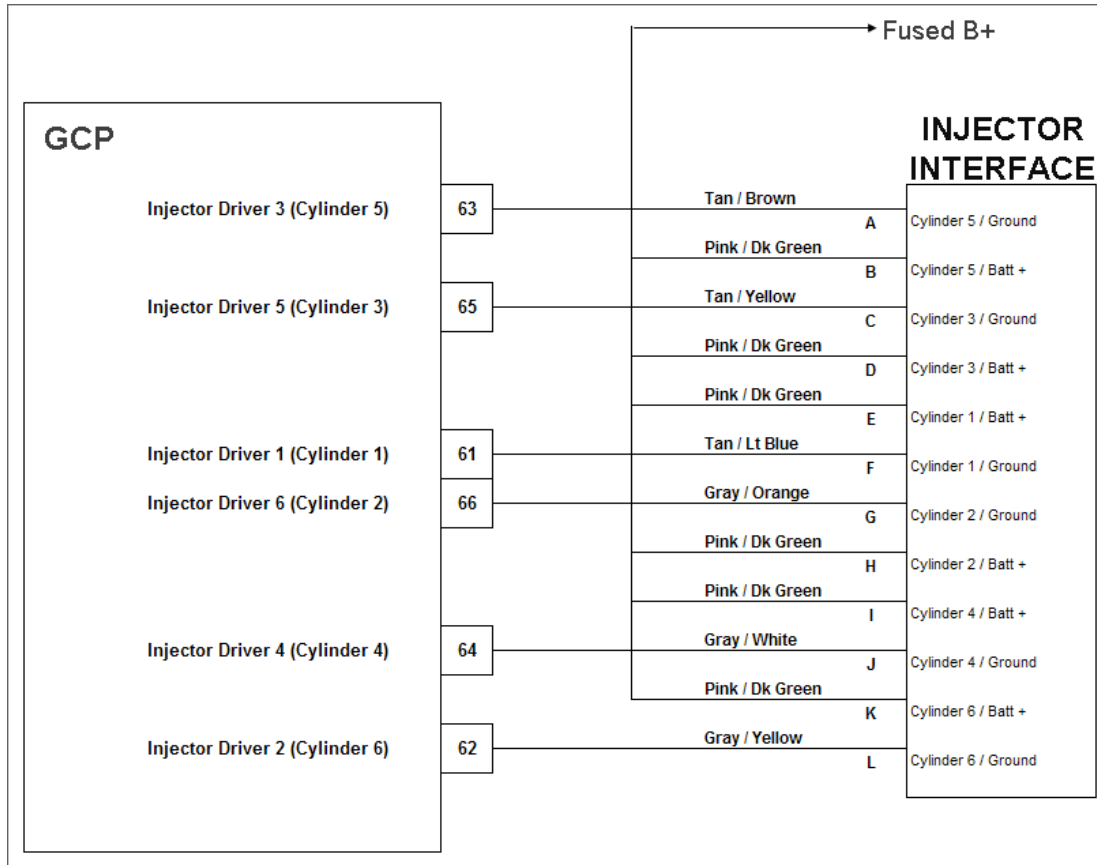

### Conditions for Setting the DTC

- Injector is in the Off State
- Low side voltage is less than 4.0 volts
- Battery voltage is above 9.0 volts
- MIL Light turned on
- Closed Loop is disabled while this fault is active
- Adaptive Learn is disabled while this fault is active.

### Circuit Description

The fuel injectors turn on when the ECM provides a ground circuit to the injector. Battery positive is constantly provided through the ignition fuse and the Pink / DK Green wire. Each Injector has a ground side driver assigned to it inside the ECM. The driver number does not match up with the mating cylinder number in each case. The driver is assigned in numerical order according to the engine firing order (4.3L = 1, 6, 5, 4, 3, 2). The ECM is monitoring the low side voltage internally in the ECM. This code will set if it sees a low voltage on the low side during an “injector off” state. This indicates the injector is open or there is a short to ground in the circuit.

The technician should check the wiring and the injector resistance. If the resistance is out of specification or you get an infinite reading on the DVOM you should replace the injector. If there is a short to ground in the wiring circuit you should repair the faulty circuit in accordance with the recommended wire repair instructions provided in this manual.

## DTC 267-Injector Driver 183 (CYL 5) Open or Short to Ground (SPN 653:FMI 5)

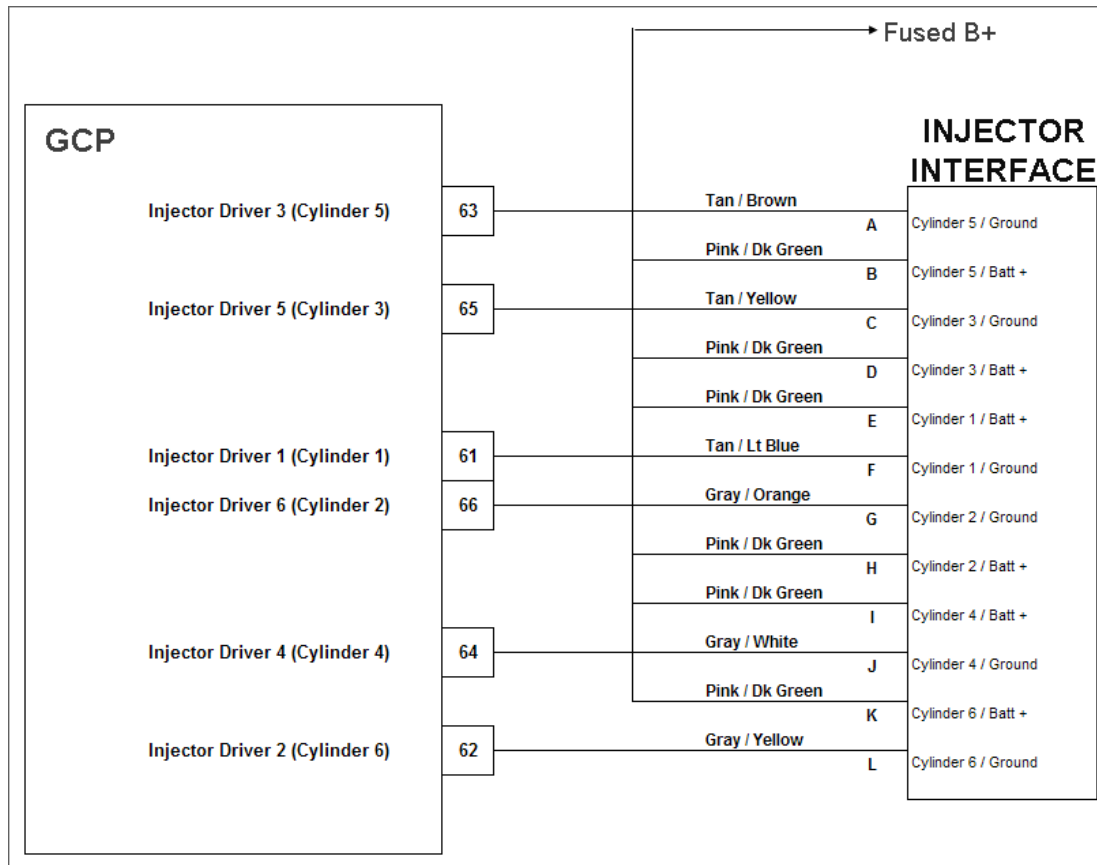

### Conditions for Setting the DTC

- Injector is in the Off State
- Low side voltage is less than 4.0 volts
- Battery voltage is above 9.0 volts
- MIL Light turned on
- Closed Loop is disabled while this fault is active
- Adaptive Learn is disabled while this fault is active.

### Circuit Description

The fuel injectors turn on when the ECM provides a ground circuit to the injector. Battery positive is constantly provided through the ignition fuse and the Pink / DK Green wire. Each Injector has a ground side driver assigned to it inside the ECM. The driver number does not match up with the mating cylinder number in each case. The driver is assigned in numerical order according to the engine firing order (4.3L = 1, 6, 5, 4, 3, 2). The ECM is monitoring the low side voltage internally in the ECM. This code will set if it sees a low voltage on the low side during an “injector off” state. This indicates the injector is open or there is a short to ground in the circuit.

The technician should check the wiring and the injector resistance. If the resistance is out of specification or you get an infinite reading on the DVOM you should replace the injector. If there is a short to ground in the wiring circuit you should repair the faulty circuit in accordance with the recommended wire repair instructions provided in this manual.



## DTC 270-Injector Driver 184 (CYL 4) Open or Short to Ground (SPN 654:FMI 5)

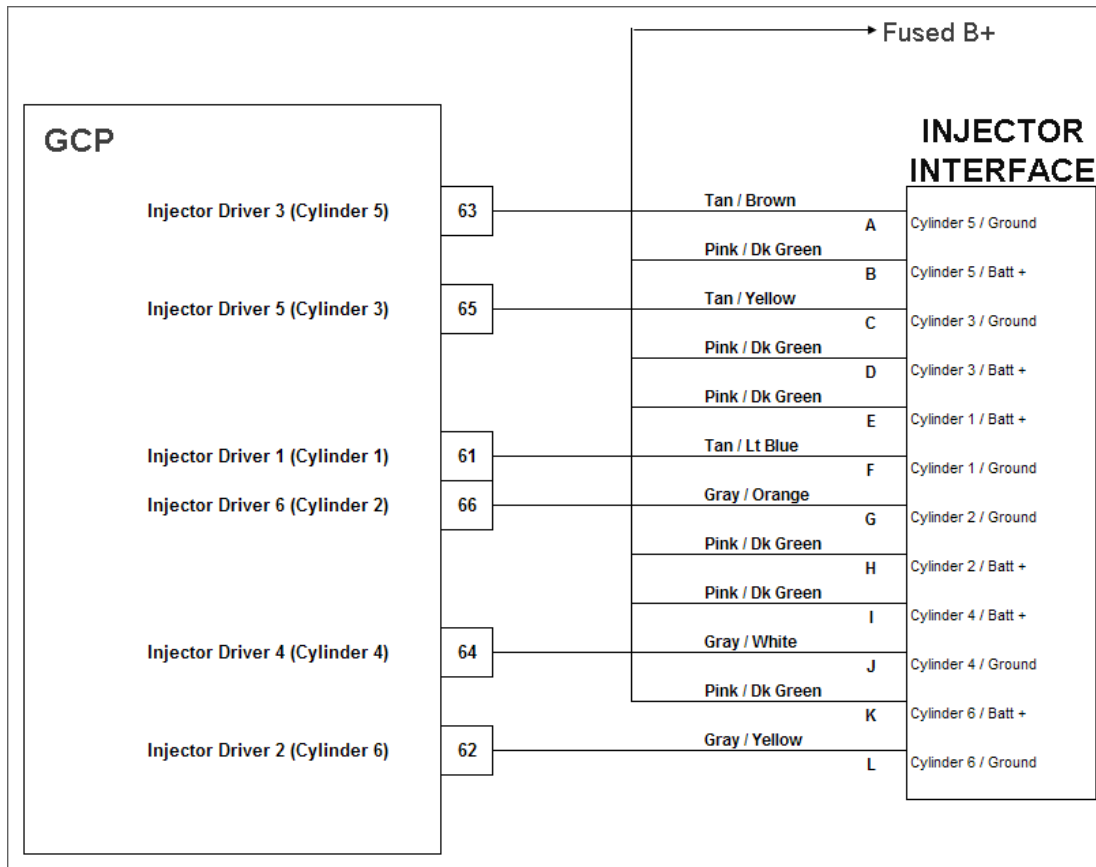

### Conditions for Setting the DTC

- Injector is in the Off State
- Low side voltage is less than 4.0 volts
- Battery voltage is above 9.0 volts
- MIL Light turned on
- Closed Loop is disabled while this fault is active
- Adaptive Learn is disabled while this fault is active.

### Circuit Description

The fuel injectors turn on when the ECM provides a ground circuit to the injector. Battery positive is constantly provided through the ignition fuse and the Pink / DK Green wire. Each Injector has a ground side driver assigned to it inside the ECM. The driver number does not match up with the mating cylinder number in each case. The driver is assigned in numerical order according to the engine firing order (4.3L = 1, 6, 5, 4, 3, 2). The ECM is monitoring the low side voltage internally in the ECM. This code will set if it sees a low voltage on the low side during an “injector off” state. This indicates the injector is open or there is a short to ground in the circuit.

The technician should check the wiring and the injector resistance. If the resistance is out of specification or you get an infinite reading on the DVOM you should replace the injector. If there is a short to ground in the wiring circuit you should repair the faulty circuit in accordance with the recommended wire repair instructions provided in this manual.

## **DTC 273-Injector Driver 5 (CYL 3) Open or Short to Ground (SPN 185:FMI 5)**

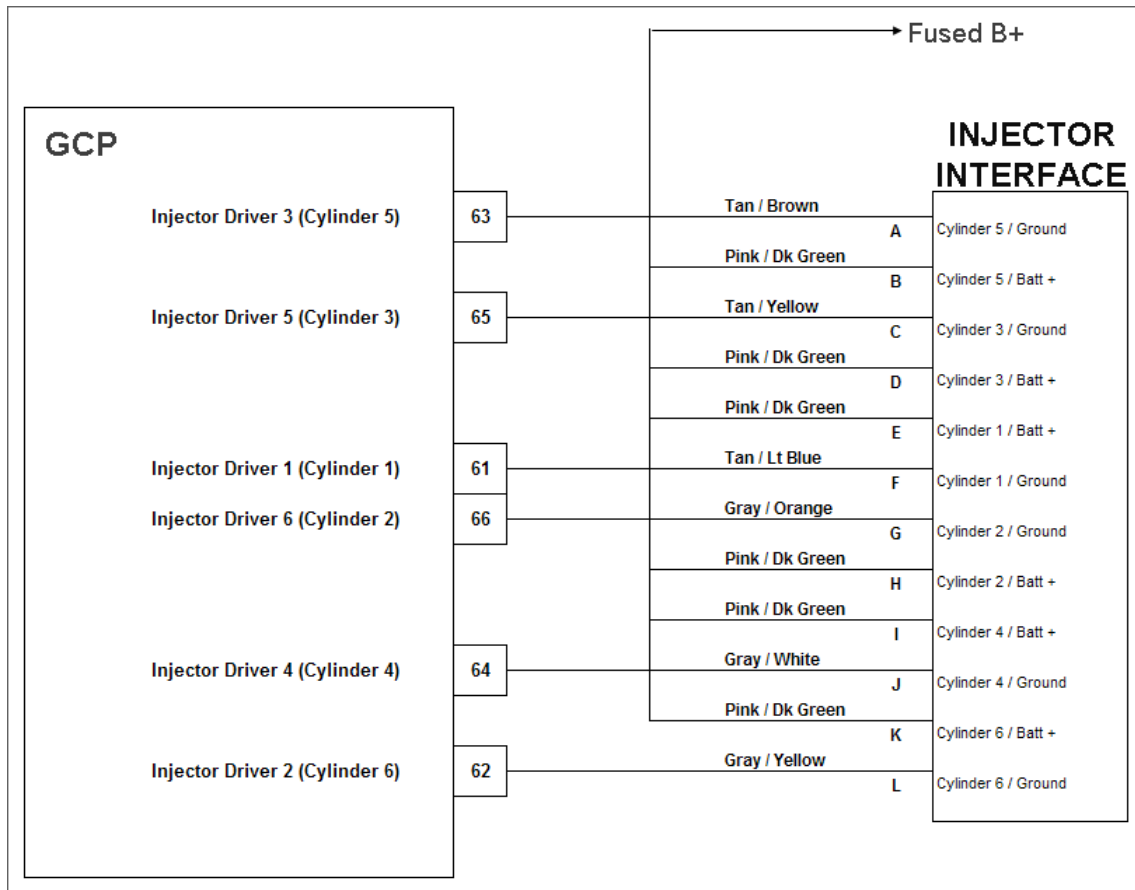

### **Conditions for Setting the DTC**

- Injector is in the Off State
- Low side voltage is less than 4.0 volts
- Battery voltage is above 9.0 volts
- MIL Light turned on
- Closed Loop is disabled while this fault is active
- Adaptive Learn is disabled while this fault is active.

### **Circuit Description**

The fuel injectors turn on when the ECM provides a ground circuit to the injector. Battery positive is constantly provided through the ignition fuse and the Pink / DK Green wire. Each Injector has a ground side driver assigned to it inside the ECM. The driver number does not match up with the mating cylinder number in each case. The driver is assigned in numerical order according to the engine firing order (4.3L = 1, 6, 5, 4, 3, 2). The ECM is monitoring the low side voltage internally in the ECM. This code will set if it sees a low voltage on the low side during an “injector off” state. This indicates the injector is open or there is a short to ground in the circuit.

The technician should check the wiring and the injector resistance. If the resistance is out of specification or you get an infinite reading on the DVOM you should replace the injector. If there is a short to ground in the wiring circuit, you should repair the faulty circuit in accordance with the recommended wire repair instructions provided in this manual.

## **DTC 276-Injector Driver 6 (CYL 2) Open or Short to Ground (SPN 186:FMI 5)**

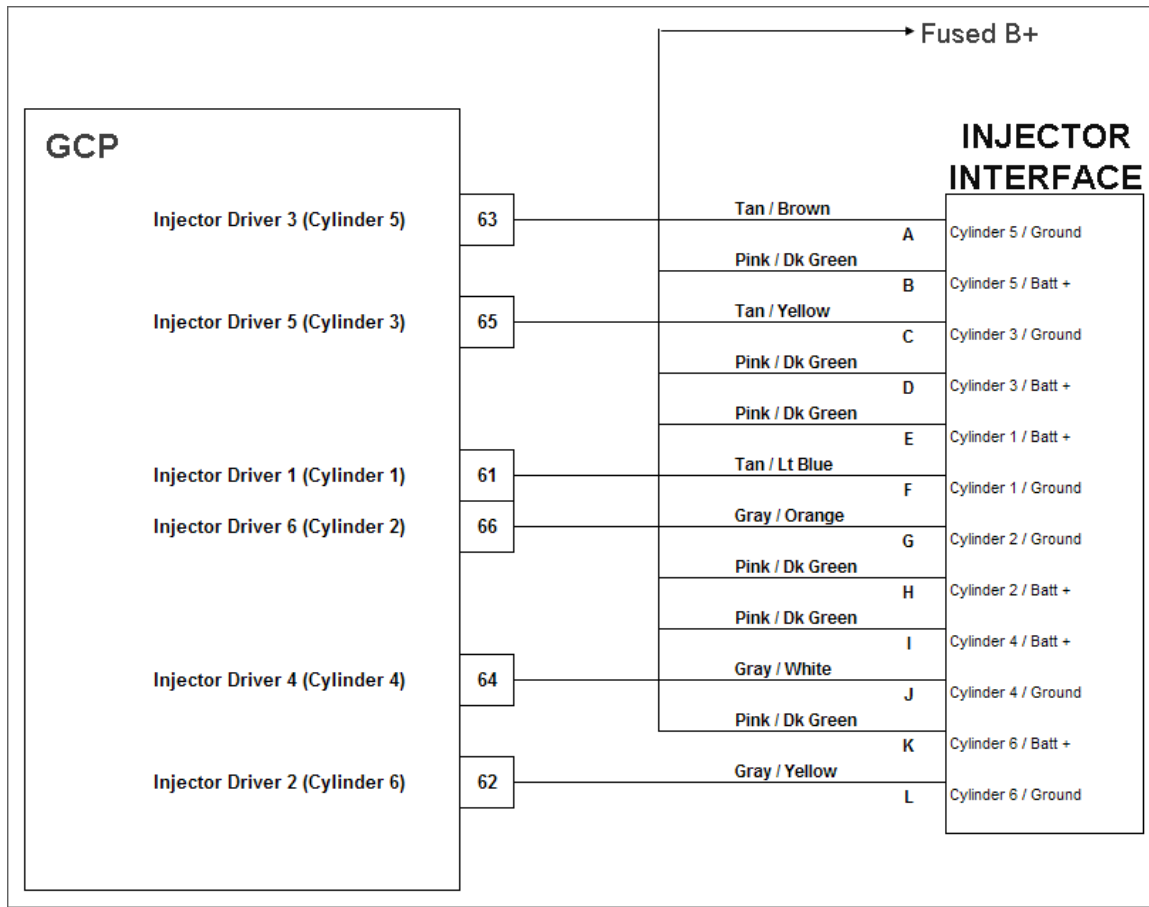

### **Conditions for Setting the DTC**

- Injector is in the Off State
- Low side voltage is less than 4.0 volts
- Battery voltage is above 9.0 volts
- MIL Light turned on
- Closed Loop is disabled while this fault is active
- Adaptive Learn is disabled while this fault is active.

### **Circuit Description**

The fuel injectors turn on when the ECM provides a ground circuit to the injector. Battery positive is constantly provided through the ignition fuse and the Pink / DK Green wire. Each Injector has a ground side driver assigned to it inside the ECM. The driver number does not match up with the mating cylinder number in each case. The driver is assigned in numerical order according to the engine firing order (4.3L = 1, 6, 5, 4, 3, 2). The ECM is monitoring the low side voltage internally in the ECM. This code will set if it sees a low voltage on the low side during an “injector off” state. This indicates the injector is open or there is a short to ground in the circuit.

The technician should check the wiring and the injector resistance. If the resistance is out of specification or you get an infinite reading on the DVOM you should replace the injector. If there is a short to ground in the wiring circuit, you should repair the faulty circuit in accordance with the recommended wire repair instructions provided in this manual.

## DTC 262-Injector Driver 1 (CYL 1) Coil Shorted (SPN 651:FMI 6)

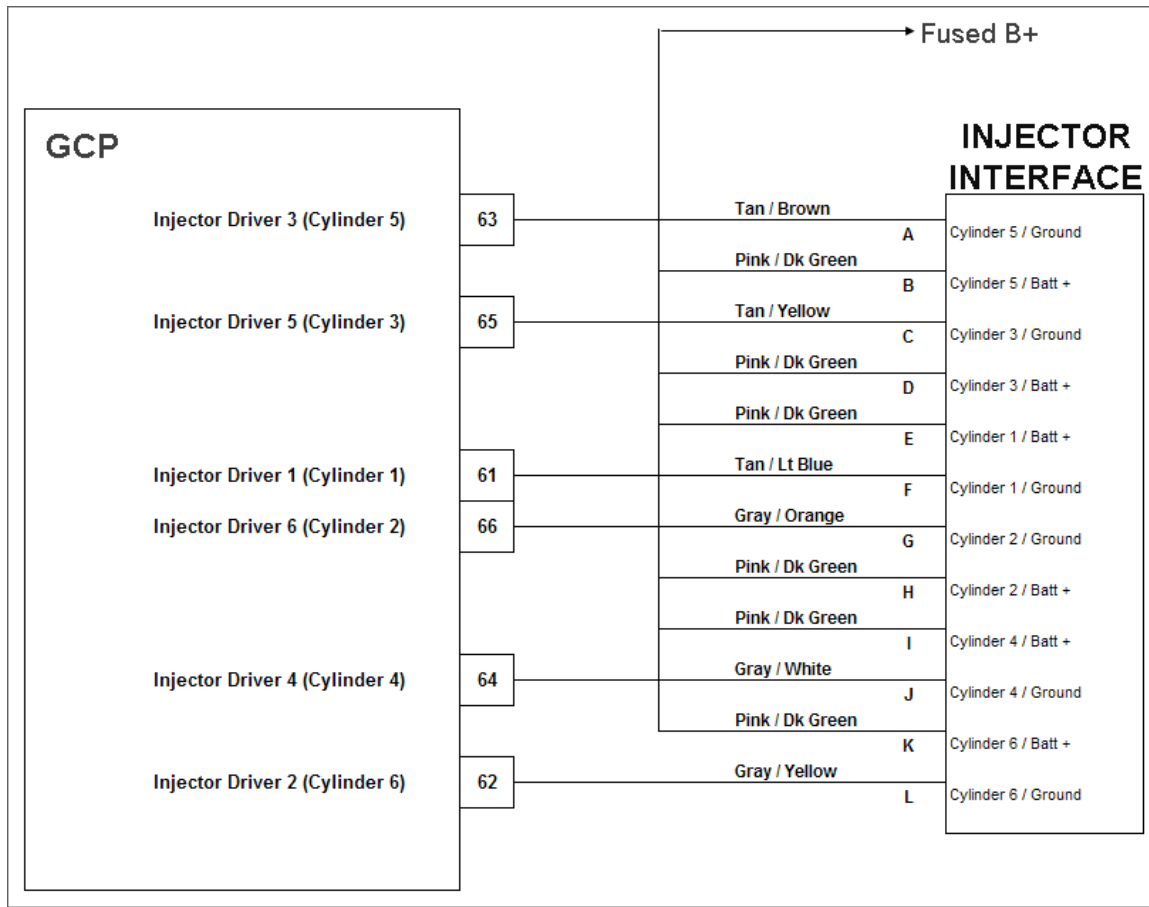

### Conditions for Setting the DTC

- Injector is in the On State
- Low side voltage is greater than 4.0 volts
- Battery voltage is less than 16.0 volts
- MIL Light turned on
- Closed Loop is disabled while this fault is active
- Adaptive Learn is disabled while this fault is active.

### Circuit Description

The fuel injectors turn on when the ECM provides a ground circuit to the injector. Battery positive is constantly provided through the ignition fuse and the Pink / DK Green wire. Each Injector has a ground side driver assigned to it inside the ECM. The driver number does not match up with the mating cylinder number in each case. The driver is assigned in numerical order according to the engine firing order (4.3L = 1, 6, 5, 4, 3, 2). The ECM is monitoring the low side voltage internally in the ECM. This code will set if it sees a high voltage on the low side during an "injector on" state. This indicates the injector likely has a short circuit internal to the injector. It could also be a result of a short from power to the ground circuit.

The technician should check the wiring and the injector resistance. If the resistance is out of specification on the DVOM you should replace the injector. If there is a short from a power circuit to the ground circuit, you should repair the faulty circuit in accordance with the recommended wire repair instructions provided in this manual.

## DTC 265-Injector Driver 2 (CYL 1) Coil Shorted (SPN 652:FMI 6)

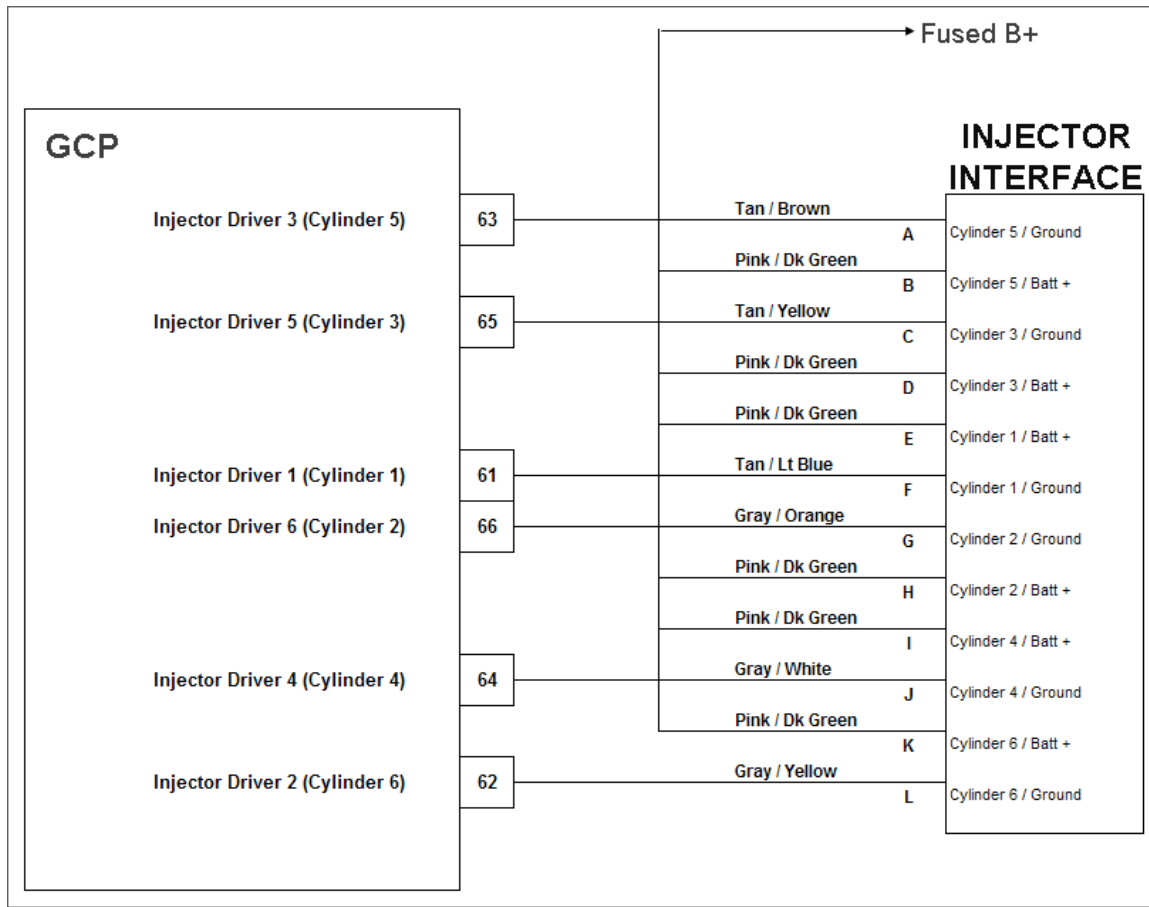

### Conditions for Setting the DTC

- Injector is in the On State
- Low side voltage is greater than 4.0 volts
- Battery voltage is less than 16.0 volts
- MIL Light turned on
- Closed Loop is disabled while this fault is active
- Adaptive Learn is disabled while this fault is active.

### Circuit Description

The fuel injectors turn on when the ECM provides a ground circuit to the injector. Battery positive is constantly provided through the ignition fuse and the Pink / DK Green wire. Each Injector has a ground side driver assigned to it inside the ECM. The driver number does not match up with the mating cylinder number in each case. The driver is assigned in numerical order according to the engine firing order (4.3L = 1, 6, 5, 4, 3, 2). The ECM is monitoring the low side voltage internally in the ECM. This code will set if it sees a high voltage on the low side during an "injector on" state. This indicates the injector likely has a short circuit internal to the injector. It could also be a result of a short from power to the ground circuit.

The technician should check the wiring and the injector resistance. If the resistance is out of specification on the DVOM you should replace the injector. If there is a short from a power circuit to the ground circuit, you should repair the faulty circuit in accordance with the recommended wire repair instructions provided in this manual.

## **DTC 268-Injector Driver 3 (CYL 5) Coil Shorted (SPN 653:FMI 6)**

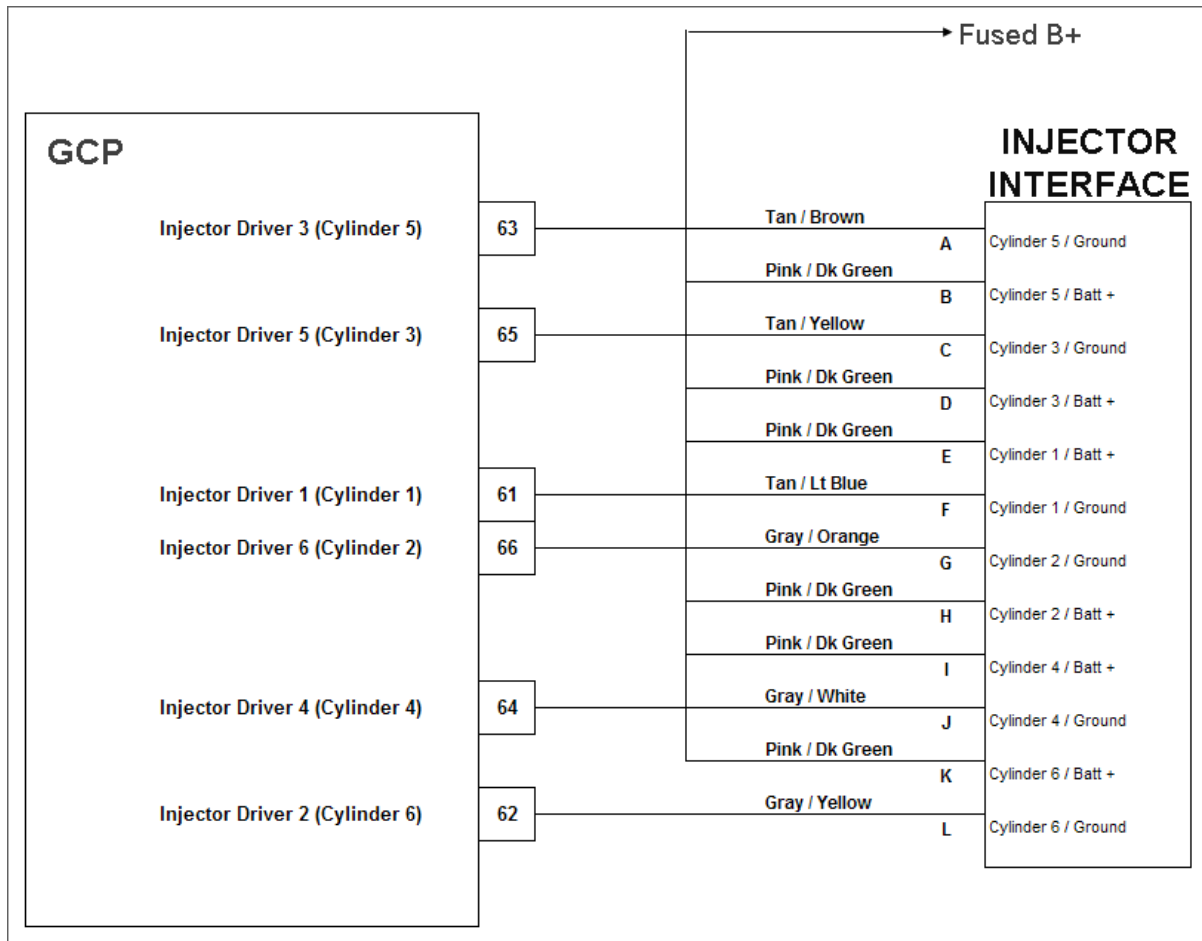

### **Conditions for Setting the DTC**

- Injector is in the On State
- Low side voltage is greater than 4.0 volts
- Battery voltage is less than 16.0 volts
- MIL Light turned on
- Closed Loop is disabled while this fault is active
- Adaptive Learn is disabled while this fault is active.

### **Circuit Description**

The fuel injectors turn on when the ECM provides a ground circuit to the injector. Battery positive is constantly provided through the ignition fuse and the Pink / DK Green wire. Each Injector has a ground side driver assigned to it inside the ECM. The driver number does not match up with the mating cylinder number in each case. The driver is assigned in numerical order according to the engine firing order (4.3L = 1, 6, 5, 4, 3, 2). The ECM is monitoring the low side voltage internally in the ECM. This code will set if it sees a high voltage on the low side during an "injector on" state. This indicates the injector likely has a short circuit internal to the injector. It could also be a result of a short from power to the ground circuit.

The technician should check the wiring and the injector resistance. If the resistance is out of specification on the DVOM you should replace the injector. If there is a short from a power circuit to the ground circuit, you should repair the faulty circuit in accordance with the recommended wire repair instructions provided in this manual.

## **DTC 271-Injector Driver 4 (CYL 4) Coil Shorted (SPN 654:FMI 6)**

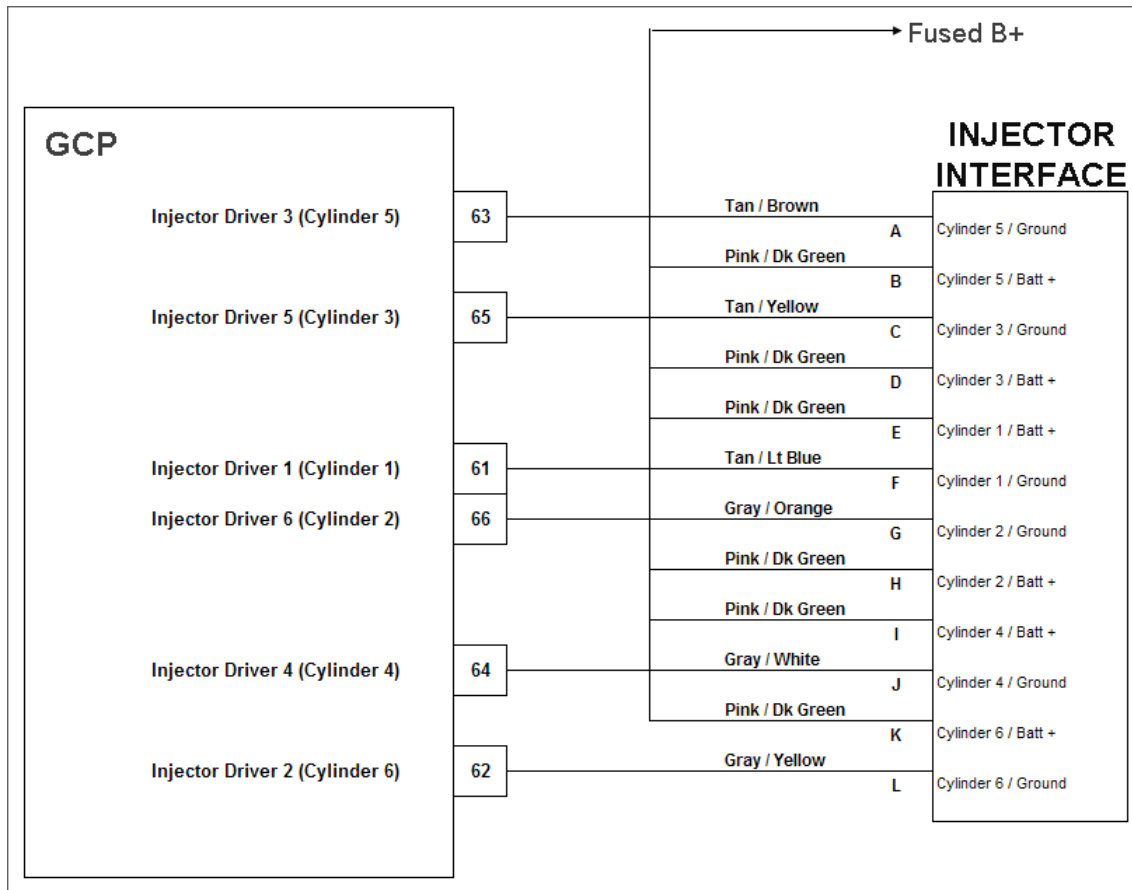

### **Conditions for Setting the DTC**

- Injector is in the On State
- Low side voltage is greater than 4.0 volts
- Battery voltage is less than 16.0 volts
- MIL Light turned on
- Closed Loop is disabled while this fault is active
- Adaptive Learn is disabled while this fault is active.

### **Circuit Description**

The fuel injectors turn on when the ECM provides a ground circuit to the injector. Battery positive is constantly provided through the ignition fuse and the Pink / DK Green wire. Each Injector has a ground side driver assigned to it inside the ECM. The driver number does not match up with the mating cylinder number in each case. The driver is assigned in numerical order according to the engine firing order (4.3L = 1, 6, 5, 4, 3, 2). The ECM is monitoring the low side voltage internally in the ECM. This code will set if it sees a high voltage on the low side during an “injector on” state. This indicates the injector likely has a short circuit internal to the injector. It could also be a result of a short from power to the ground circuit.

The technician should check the wiring and the injector resistance. If the resistance is out of specification on the DVOM you should replace the injector. If there is a short from a power circuit to the ground circuit, you should repair the faulty circuit in accordance with the recommended wire repair instructions provided in this manual.

## DTC 274-Injector Driver 5 (CYL 3) Coil Shorted (SPN 655:FMI 6)

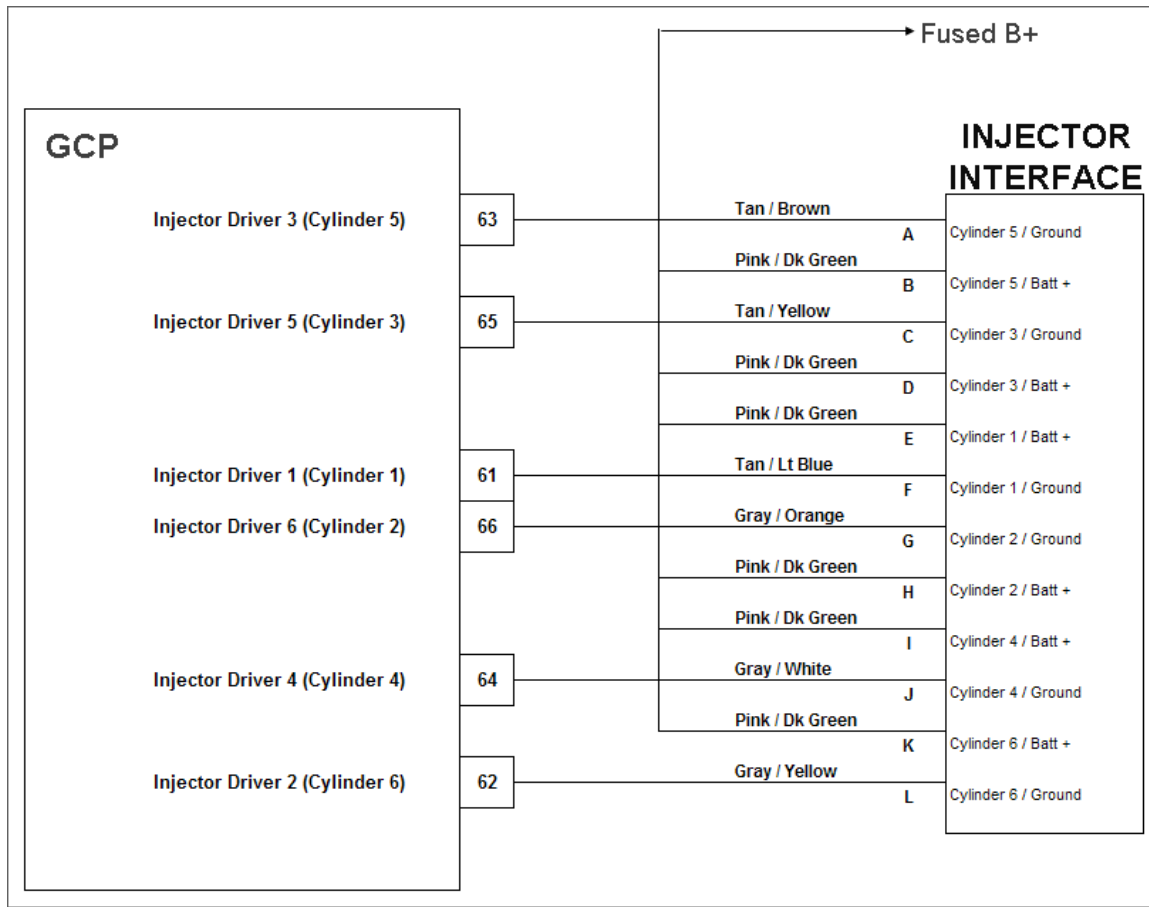

### Conditions for Setting the DTC

- Injector is in the On State
- Low side voltage is greater than 4.0 volts
- Battery voltage is less than 16.0 volts
- MIL Light turned on
- Closed Loop is disabled while this fault is active
- Adaptive Learn is disabled while this fault is active.

### Circuit Description

The fuel injectors turn on when the ECM provides a ground circuit to the injector. Battery positive is constantly provided through the ignition fuse and the Pink / DK Green wire. Each Injector has a ground side driver assigned to it inside the ECM. The driver number does not match up with the mating cylinder number in each case. The driver is assigned in numerical order according to the engine firing order (4.3L = 1, 6, 5, 4, 3, 2). The ECM is monitoring the low side voltage internally in the ECM. This code will set if it sees a high voltage on the low side during an “injector on” state. This indicates the injector likely has a short circuit internal to the injector. It could also be a result of a short from power to the ground circuit.

The technician should check the wiring and the injector resistance. If the resistance is out of specification on the DVOM you should replace the injector. If there is a short from a power circuit to the ground circuit, you should repair the faulty circuit in accordance with the recommended wire repair instructions provided in this manual.



## **DTC 277-Injector Driver 6 (CYL 2) Coil Shorted (SPN 656:FMI 6)**

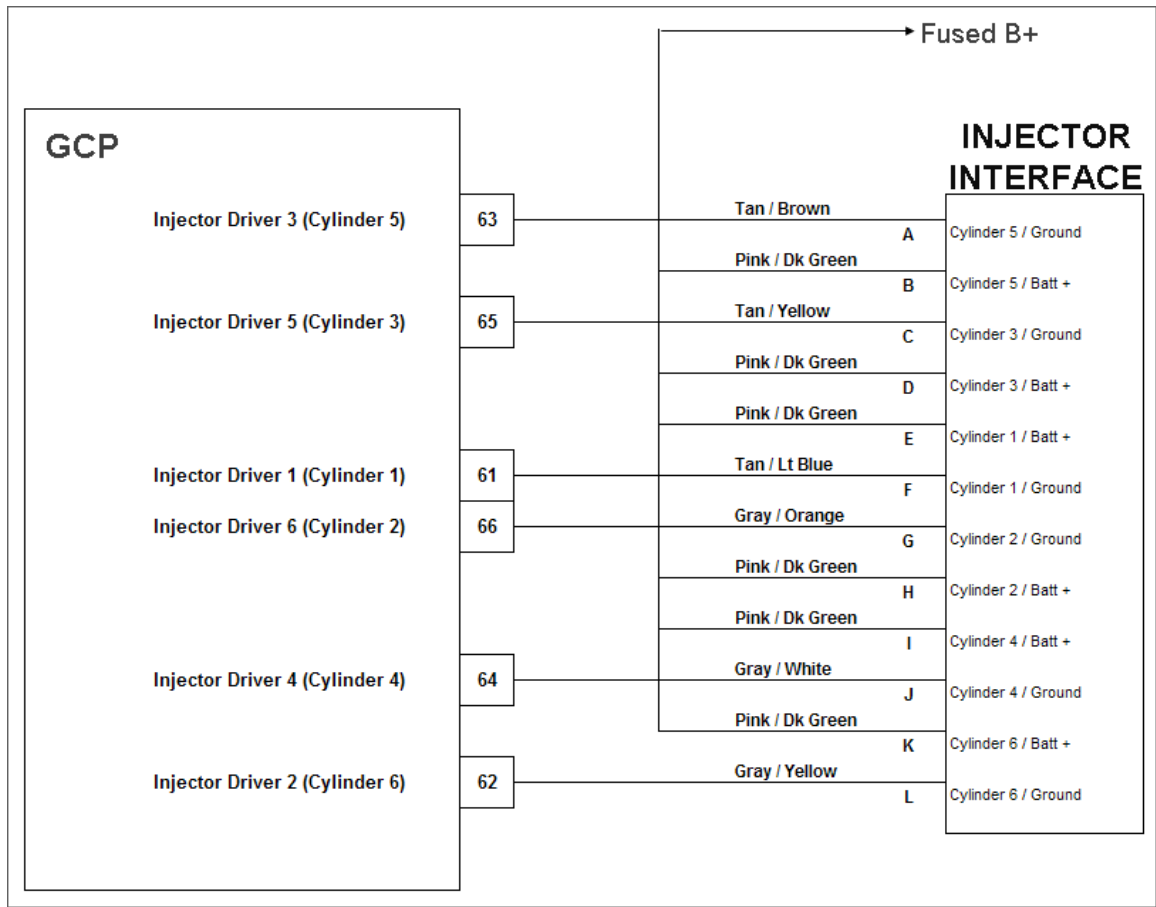

### **Conditions for Setting the DTC**

- Injector is in the On State
- Low side voltage is greater than 4.0 volts
- Battery voltage is less than 16.0 volts
- MIL Light turned on
- Closed Loop is disabled while this fault is active
- Adaptive Learn is disabled while this fault is active.

### **Circuit Description**

The fuel injectors turn on when the ECM provides a ground circuit to the injector. Battery positive is constantly provided through the ignition fuse and the Pink / DK Green wire. Each Injector has a ground side driver assigned to it inside the ECM. The driver number does not match up with the mating cylinder number in each case. The driver is assigned in numerical order according to the engine firing order (4.3L = 1, 6, 5, 4, 3, 2). The ECM is monitoring the low side voltage internally in the ECM. This code will set if it sees a high voltage on the low side during an “injector on” state. This indicates the injector likely has a short circuit internal to the injector. It could also be a result of a short from power to the ground circuit.

The technician should check the wiring and the injector resistance. If the resistance is out of specification on the DVOM you should replace the injector. If there is a short from a power circuit to the ground circuit, you should repair the faulty circuit in accordance with the recommended wire repair instructions provided in this manual.

## DTC 336-Crank Sync Noise (SPN 636:FMI 2)

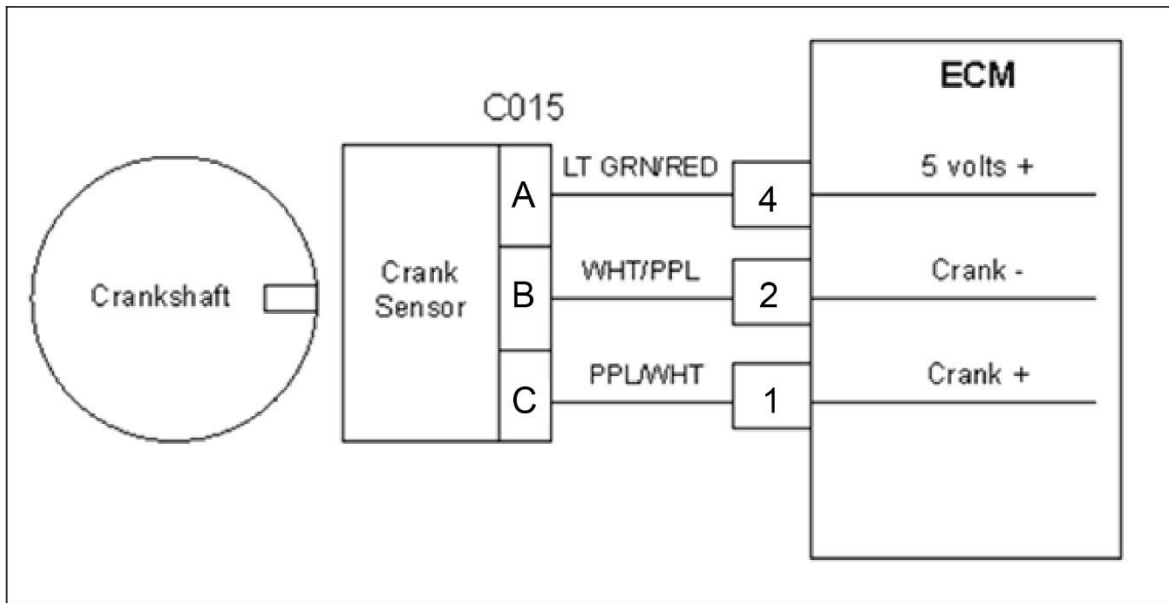

### Conditions for setting the DTC

- Crankshaft Position sensor
- Check Condition- Engine running
- Fault Condition- 1 invalid crank re-sync in less than 800 ms
- Adaptive- Disabled
- MIL- On during active fault

### Circuit Description

The Crankshaft position sensor is a 5-volt powered sensor mounted to the lower front engine block. A pulse wheel located on the crankshaft is used to measure engine rpm and its signal is used to synchronize the ignition and fuel systems. This fault will set if no signal is present for 800ms or longer.

Step	Action	Value(s)	Yes	No
1	Did you perform the On-Board (OBD) System Check?	-	Go to Step (2)	Go to OBD System Check Section
2	<ul style="list-style-type: none"> <li>Check that the ECM ground terminals C010, C022 and C023 are clean and tight</li> </ul> Are the ground terminals clean and tight?		Go to Step (3)	Repair the circuit as necessary. Refer to Wiring Repairs in Engine Electrical.
3	<ul style="list-style-type: none"> <li>Key On, Engine OFF</li> <li>Disconnect the CKP (Crankshaft position) Sensor connector C015</li> <li>Using A DVOM check for voltage at the CKP sensor connector pin 1 and engine ground</li> </ul> <b>(CHECK THIS BEFORE THE POWER RELAYS SHUTS OFF)</b> Do you have voltage?	5.0 volts	Go to Step (4)	Repair the circuit as necessary. Refer to Wiring Repairs in Engine Electrical.
4	<ul style="list-style-type: none"> <li>Key OFF</li> <li>Disconnect ECM connector C001</li> <li>Using a DVOM check for continuity between CKP connector pin B and ECM connector pin 2</li> </ul> Do you have continuity between them?		Go to Step (5)	Repair the circuit as necessary. Refer to Wiring Repairs in Engine Electrical.
5	<ul style="list-style-type: none"> <li>Using a DVOM check for continuity between CKP connector pin C and ECM connector pin 1</li> </ul> Do you have continuity between them?		Go to Step (6)	Repair the circuit as necessary. Refer to Wiring Repairs in Engine Electrical.
6	<ul style="list-style-type: none"> <li>Inspect the CKP connector C015 terminals for damage, corrosion or contamination</li> </ul> Did you find a problem?		Repair the circuit as necessary. Refer to Wiring Repairs in Engine Electrical.	Go to Step (7)
7	<ul style="list-style-type: none"> <li>Inspect the ECM connector C001 terminals 4, 2, and 1 for damage, corrosion or contamination</li> </ul> Did you find a problem?		Repair the circuit as necessary. Refer to Wiring Repairs in Engine Electrical.	Go to step (8)

Step	Action	Value(s)	Yes	No
8	<ul style="list-style-type: none"> <li>Replace CKP sensor</li> </ul> Is the replacement complete?		Go to Step (10)	-
9	<ul style="list-style-type: none"> <li>Replace ECM</li> </ul> Is the replacement complete?		Go to Step (11)	-
10	<ul style="list-style-type: none"> <li>Remove all test equipment except the DST.</li> <li>Connect any disconnected components, fuses, etc.</li> <li>Using the DST clear DTC information from the ECM.</li> <li>Turn the ignition OFF and wait 30 seconds.</li> <li>Start the engine and operate the vehicle to full operating temperature</li> <li>Observe the MIL</li> <li>Observe engine performance and drivability</li> <li>After operating the engine within the test parameters of DTC-336 check for any stored codes.</li> </ul> Does the engine operate normally with no stored codes?		System OK	Go to Step (9)
11	<ul style="list-style-type: none"> <li>Remove all test equipment except the DST.</li> <li>Connect any disconnected components, fuses, etc.</li> <li>Using the DST clear DTC information from the ECM.</li> <li>Turn the ignition OFF and wait 30 seconds.</li> <li>Start the engine and operate the vehicle to full operating temperature</li> <li>Observe the MIL</li> <li>Observe engine performance and drivability</li> <li>After operating the engine within the test parameters of DTC-336 check for any stored codes.</li> </ul> Does the engine operate normally with no stored codes?		System OK	Go to OBD System Check

## DTC 337-Crank Loss (SPN 636:FMI 4)

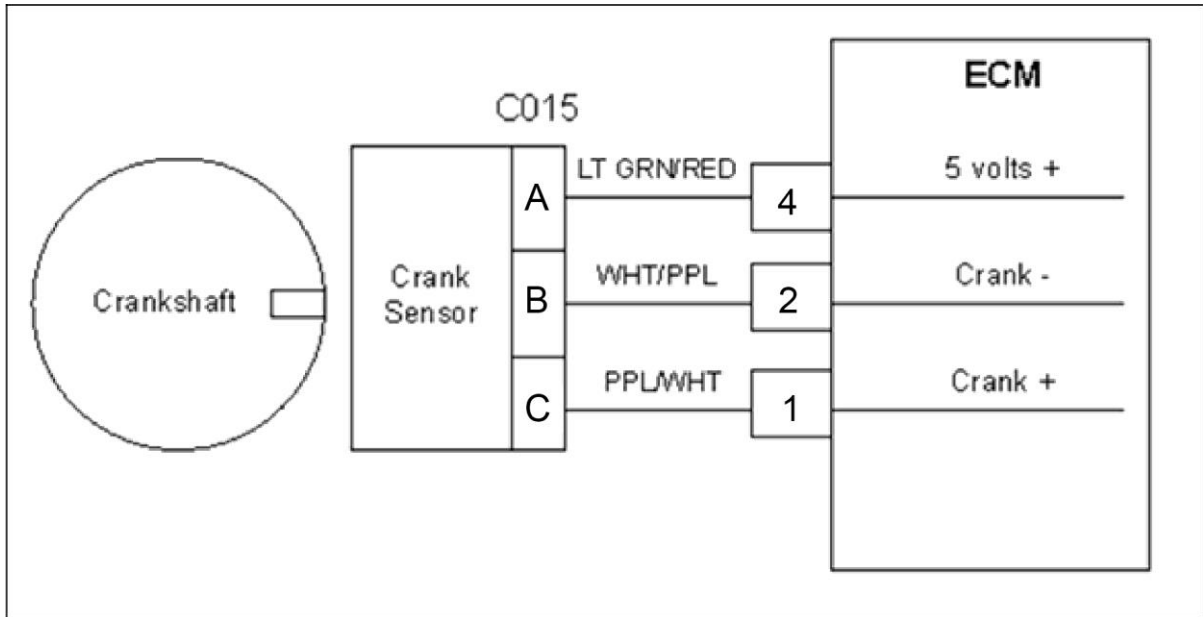

### Conditions for setting the DTC

- Crankshaft position sensor
- Check Condition- Engine cranking
- Fault Condition- 6 cam pulse signals without crankshaft activity
- MIL- On during active fault
- Adaptive- Disabled

### Circuit Description

The Crankshaft position sensor is a 5-volt powered sensor mounted to the lower front engine block. A pulse wheel located on the crankshaft is used to measure engine rpm and its signal is used to synchronize the ignition and fuel systems. The ECM must see a valid Crankshaft position signal while cranking. If no crankshaft signal is present for 6 cam pulses this fault will set.

Step	Action	Value(s)	Yes	No
1	Did you perform the On-Board (OBD) System Check?	-	Go to Step (2)	Go to OBD System Check Section
2	<ul style="list-style-type: none"> <li>Check that the ECM ground terminals C010, C022 and C023 are clean and tight</li> </ul> Are the ground terminals clean and tight?		Go to Step (3)	Repair the circuit as necessary. Referto Wiring Repairs in Engine Electrical.
3	<ul style="list-style-type: none"> <li>Key OFF</li> <li>Disconnect the CKP (Crankshaft Position)Sensor connector C015</li> <li>Using A DVOM check for voltage at the CKP sensor connector pin A and engine ground</li> </ul> <b>(CHECK THIS BEFORE THE POWER RELAYSHUTS OFF)</b> Do you have voltage?	5.0 volts	Go to Step (4)	Repair the circuit as necessary. Referto Wiring Repairs in Engine Electrical.
4	<ul style="list-style-type: none"> <li>Key OFF</li> <li>Disconnect ECM connector C001</li> <li>Using a DVOM check for continuity between CKP connector pin B and ECM connector pin2</li> </ul> Do you have continuity between them?		Go to Step (5)	Repair the circuit as necessary. Referto Wiring Repairs in Engine Electrical.
5	<ul style="list-style-type: none"> <li>Using a DVOM check for continuity between CKP connector pin C and ECM connector pin1</li> </ul> Do you have continuity between them?		Go to Step (6)	Repair the circuit as necessary. Referto Wiring Repairs in Engine Electrical.
6	<ul style="list-style-type: none"> <li>Inspect the CKP connector C015 terminals for damage, corrosion or contamination</li> </ul> Did you find a problem?		Repair the circuit as necessary. Referto Wiring Repairs in Engine Electrical.	Go to Step (7)
7	<ul style="list-style-type: none"> <li>Inspect the ECM connector C001 terminals 4, 2, and 1 for damage, corrosion or contamination</li> </ul> Did you find a problem		Repair the circuit as necessary. Referto Wiring Repairs in Engine Electrical.	Go to step (8)

Step	Action	Value(s)	Yes	No
8	<ul style="list-style-type: none"> <li>Replace the CKP sensor Is the replacement complete?</li> </ul>		Go to Step (10)	-
9	<ul style="list-style-type: none"> <li>Replace ECM Is the replacement complete?</li> </ul>		Go to Step (11)	-
10	<ul style="list-style-type: none"> <li>Remove all test equipment except the DST.</li> <li>Connect any disconnected components, fuses, etc.</li> <li>Using the DST clear DTC information from the ECM.</li> <li>Turn the ignition OFF and wait 30 seconds.</li> <li>Start the engine and operate the vehicle to full operating temperature</li> <li>Observe the MIL</li> <li>Observe engine performance and drivability</li> <li>After operating the engine within the test parameters of DTC-337 check for any stored codes.</li> </ul> <p>Does the engine operate normally with no stored codes?</p>		System OK	Go to Step (9)
11	<ul style="list-style-type: none"> <li>Remove all test equipment except the DST.</li> <li>Connect any disconnected components, fuses, etc.</li> <li>Using the DST clear DTC information from the ECM.</li> <li>Turn the ignition OFF and wait 30 seconds.</li> <li>Start the engine and operate the vehicle to full operating temperature</li> <li>Observe the MIL</li> <li>Observe engine performance and drivability</li> <li>After operating the engine within the test parameters of DTC-337 check for any stored codes.</li> </ul> <p>Does the engine operate normally with no stored codes?</p>		System OK	Go to OBD System Check

## DTC 341-Camshaft Sync Noise (SPN 723:FMI 2)

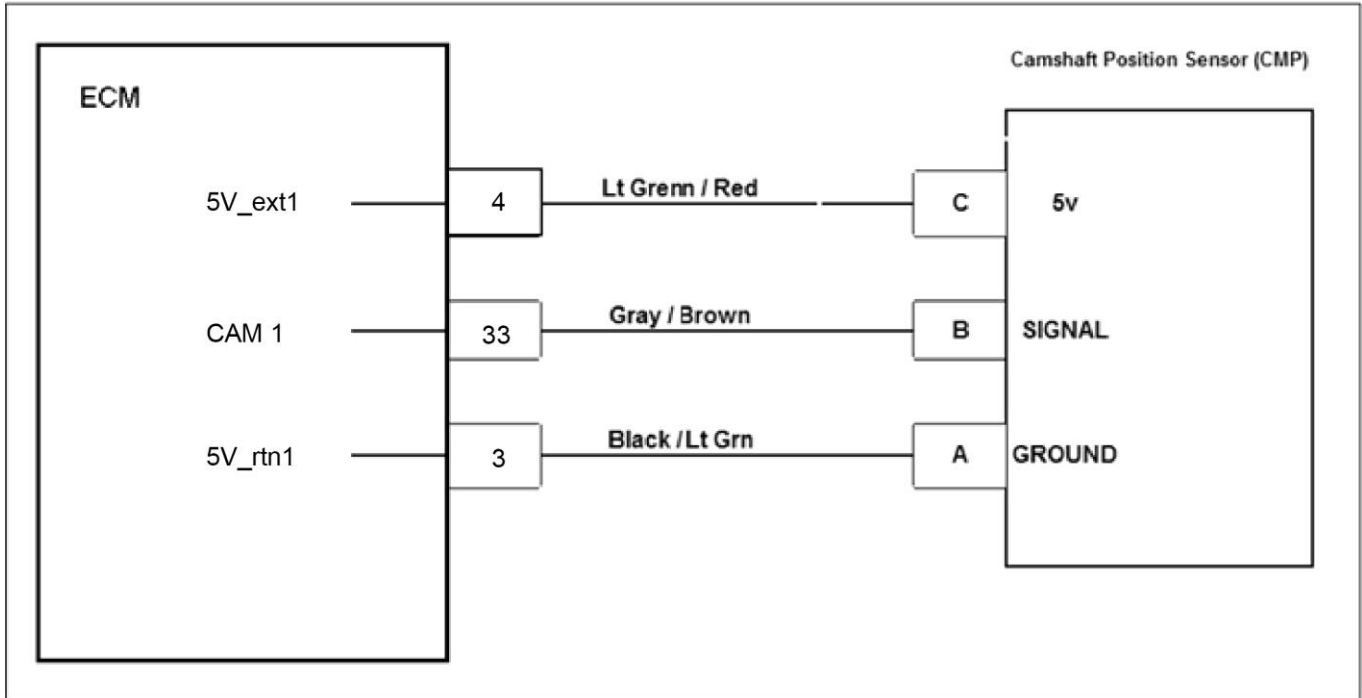

### Conditions for Setting the DTC

- Camshaft position sensor
- Check Condition-Cranking or Running
- Fault Condition-1 invalid cam re-sync in 700ms or less
- Adaptive Learn disabled
- MIL-ON

### Circuit Description

The CMP (Camshaft Position Sensor) is used to synchronize the fuel and ignition systems. This fault will set if the ECM detects erroneous pulses from the camshaft position sensor causing invalid cam re-sync. MIL light will become active and Adaptive Learn will be disabled.



Step	Action	Value(s)	Yes	No
1	Did you perform the On-Board (OBD) System Check?	-	Go to Step (2)	Go to OBD System Check Section
2	<ul style="list-style-type: none"> <li>Check that the ECM ground terminal C010 is clean, tight and in the proper location</li> </ul> Are the ground terminals clean and tight?		Go to Step (3)	Repair the circuit as necessary. Refer to Wiring Repairs in Engine Electrical.
3	<ul style="list-style-type: none"> <li>Key OFF</li> <li>Disconnect the CMP (Camshaft position)Sensor connector C016</li> <li>Using A DVOM check for voltage at the CMP sensor connector pin C and engine ground</li> </ul> Do you have voltage?	5.0 volts	Go to Step (4)	Repair the circuit as necessary. Refer to Wiring Repairs in Engine Electrical.
4	<ul style="list-style-type: none"> <li>Key OFF</li> <li>Disconnect ECM connector C001</li> <li>Using a DVOM check for continuity between CMP connector pin A and ECM connector pin 3</li> </ul> Do you have continuity between them?		Go to Step (5)	Repair the circuit as necessary. Refer to Wiring Repairs in Engine Electrical.
5	<ul style="list-style-type: none"> <li>Using a DVOM check for continuity between CMP connector pin B and ECM connector pin 33</li> </ul> Do you have continuity between them?		Go to Step (6)	Repair the circuit as necessary. Refer to Wiring Repairs in Engine Electrical.
6	<ul style="list-style-type: none"> <li>Inspect the CMP connector terminals for damage, corrosion or contamination</li> </ul> Did you find a problem?		Repair the circuit as necessary. Refer to Wiring Repairs in Engine Electrical.	Go to Step (7)
7	<ul style="list-style-type: none"> <li>Inspect the ECM connector C001 terminals 4, 33, and 3 for damage, corrosion or contamination</li> </ul> Did you find a problem?		Repair the circuit as necessary. Refer to Wiring Repairs in Engine Electrical.	Go to Step (8)
8	<ul style="list-style-type: none"> <li>Replace CMP sensor</li> </ul> Is the replacement complete?		Go to Step (10)	-

Step	Action	Value(s)	Yes	No
9	<ul style="list-style-type: none"> <li>Replace ECM</li> </ul> Is the replacement complete?		Go to Step (11)	-
10	<ul style="list-style-type: none"> <li>Remove all test equipment except the DST.</li> <li>Connect any disconnected components, fuses, etc.</li> <li>Using the DST clear DTC information from the ECM.</li> <li>Turn the ignition OFF and wait 30 seconds.</li> <li>Start the engine and operate the vehicle to full operating temperature</li> <li>Observe the MIL</li> <li>Observe engine performance and drivability</li> <li>After operating the engine within the test parameters of DTC-341 check for any stored codes.</li> </ul> Does the engine operate normally with no stored codes?		System OK	Go to Step (9)
11	<ul style="list-style-type: none"> <li>Remove all test equipment except the DST.</li> <li>Connect any disconnected components, fuses, etc.</li> <li>Using the DST clear DTC information from the ECM.</li> <li>Turn the ignition OFF and wait 30 seconds.</li> <li>Start the engine and operate the vehicle to full operating temperature</li> <li>Observe the MIL</li> <li>Observe engine performance and drivability</li> <li>After operating the engine within the test parameters of DTC-341 check for any stored codes.</li> </ul> Does the engine operate normally with no stored codes?		System OK	Go to OBD System Check

## DTC 342-Camshaft Sensor Loss (SPN 723:FMI 4)

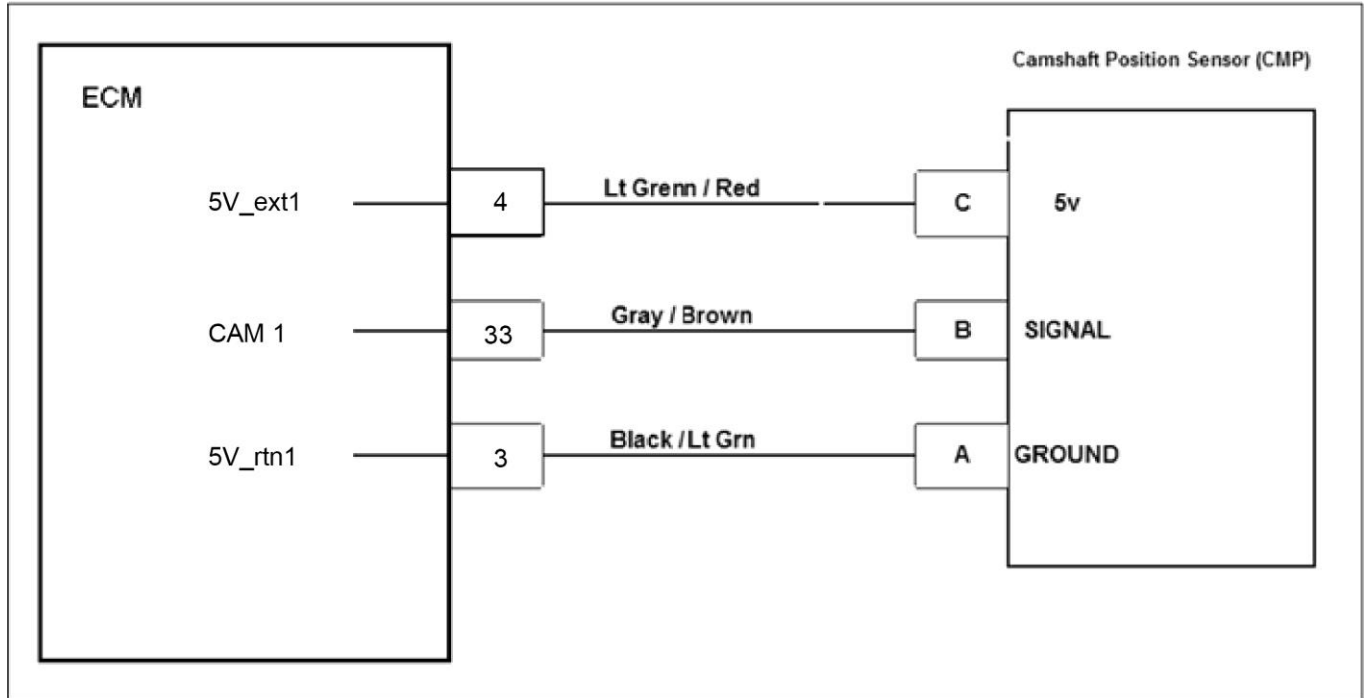

### Conditions for Setting the DTC

- CMP (Camshaft Position Sensor)
- Check Condition-Engine Cranking or Running
- Fault Condition-No cam pulse in 2.5 cycles with engine speed greater than 100 rpm
- MIL-ON for active fault
- Adaptive-Disabled

### Circuit Description

The CMP (Camshaft Position Sensor) is used to synchronize the fuel and ignition systems. This fault will set if the ECM does not detect a cam pulse in 2.5 engine cycles whenever the engine is greater than 100 rpm. The engine may not run with this fault present.

Step	Action	Value(s)	Yes	No
1	Did you perform the On-Board (OBD) System Check?	-	Go to Step (2)	Go to OBD System Check Section
2	<ul style="list-style-type: none"> <li>Check that the ECM ground terminal C010 is clean, tight and in the proper location</li> </ul> Is the ground terminal clean tight and in the proper location?		Go to Step (3)	Repair the circuit as necessary. Referto wiring harness repair section.
3	<ul style="list-style-type: none"> <li>Key OFF</li> <li>Disconnect the CMP (Camshaft Position)Sensor connector C016</li> <li>Key ON</li> <li>Using A DVOM check for voltage at the CMP sensor connector pin C and engine ground (RUN THIS VOLTAGE CHECK BEFORE THEPOWER RELAY SHUTS OFF)</li> </ul> Do you have voltage?	5.0 volts	Go to Step (4)	Repair the circuit as necessary. Referto wiring harness repair section.
4	<ul style="list-style-type: none"> <li>Key OFF</li> <li>Disconnect ECM connector C001</li> <li>Using a DVOM check for continuity between CMP connector pin A and ECM connector pin 3</li> </ul> Do you have continuity between them?		Go to Step (5)	Repair the circuit as necessary. Referto wiring harness repair section.
5	<ul style="list-style-type: none"> <li>Using a DVOM check for continuity between CMP connector pin B and ECM connector pin 33</li> </ul> Do you have continuity between them?		Go to Step (6)	Repair the circuit as necessary. Referto wiring harness repair section.
6	<ul style="list-style-type: none"> <li>Inspect the CMP connector terminals for damage, corrosion or contamination</li> </ul> Did you find a problem?		Repair the circuit as necessary. Referto wiring harness repair section.	Go to Step (7)
7	<ul style="list-style-type: none"> <li>Inspect the ECM connector terminals 4, 33 and 3 for damage, corrosion or contamination</li> </ul> Did you find a problem?		Repair the circuit as necessary. Referto wiring harness repair section.	Go to Step (8)
8	<ul style="list-style-type: none"> <li>Replace the CMP.</li> </ul> Is the replacement complete?		Go to Step (10)	-
9	<ul style="list-style-type: none"> <li>Replace ECM</li> </ul> Is the replacement complete?		Go to Step (11)	-

Step	Action	Value(s)	Yes	No
10	<ul style="list-style-type: none"> <li>• Remove all test equipment except the DST.</li> <li>• Connect any disconnected components, fuses, etc.</li> <li>• Using the DST clear DTC information from the ECM.</li> <li>• Turn the ignition OFF and wait 30 seconds.</li> <li>• Start the engine and operate the vehicle to full operating temperature</li> <li>• Observe the MIL</li> <li>• Observe engine performance and drivability</li> <li>• After operating the engine within the test parameters of DTC-342 check for any stored codes.</li> </ul> <p>Does the engine operate normally with no stored codes?</p>		System OK	Go to Step (9)
11	<ul style="list-style-type: none"> <li>• Remove all test equipment except the DST.</li> <li>• Connect any disconnected components, fuses, etc.</li> <li>• Using the DST clear DTC information from the ECM.</li> <li>• Turn the ignition OFF and wait 30 seconds.</li> <li>• Start the engine and operate the vehicle to full operating temperature</li> <li>• Observe the MIL</li> <li>• Observe engine performance and drivability</li> <li>• After operating the engine within the test parameters of DTC-342 check for any stored codes.</li> </ul> <p>Does the engine operate normally with no stored codes?</p>		System OK	Go to OBD System Check

## DTC-359 Fuel Run-out Longer Than Expected (SPN 632:FMI 31)

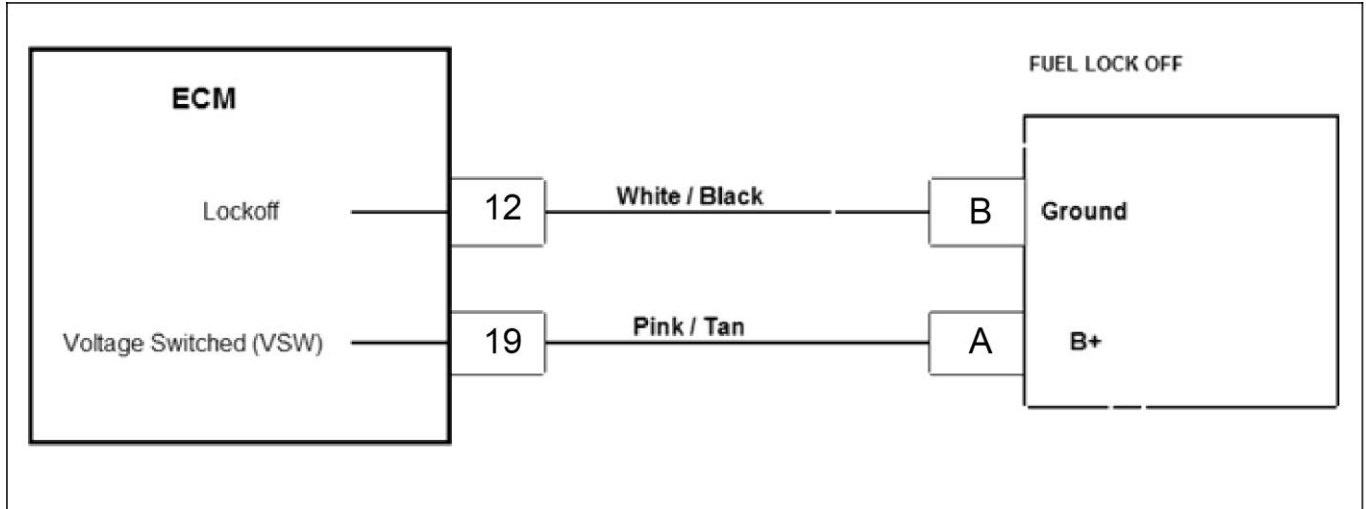

### Conditions for Setting the DTC

- LPG lock-off valve
- Check Condition-Key OFF
- Fault Condition-Engine run down time greater than 20 seconds
- MIL-ON

### Circuit Description

The LPG lock off valve is supplied system battery power from the VSW fused source. The ECM then provides a path to ground to turn the valve on. This fault will set in the event the engine continues to run for more than 20 seconds after the key is turned off. This fault indicates a possible problem with the electric LPG lock off solenoid.

Step	Action	Value(s)	Yes	No
1	Did you perform the On-Board (OBD) System Check?	-	Go to Step (2)	
2	<ul style="list-style-type: none"> <li>Disconnect the LPG shut off solenoid connector C003</li> <li>Using a DVOM check for power across terminals A and B while cranking the engine, then turn the key to the OFF position</li> </ul> Did the voltage immediately turn OFF with the key cycle?	System Voltage	Go to Step (3)	Go to Step (5)
3	<ul style="list-style-type: none"> <li>Turn off the LPG manual valve at the fuel tank</li> <li>Start the engine and let it idle until the engine stops.</li> </ul> (THIS MAY TAKE SEVERAL MINUTES) Did the engine ever stop?		Intermittent problem. See intermittent problems in the electrical section of this manual.	Go to Step (4)
4	<ul style="list-style-type: none"> <li>Replace the LPG shut off solenoids</li> </ul> the replacement complete?		Go to Step (8)	-
5	<ul style="list-style-type: none"> <li>Key OFF</li> <li>Disconnect the ECM wire harness connector C001</li> <li>Using a DVOM check for continuity between ECM pin 12 and engine ground</li> </ul> Do you have continuity?		Repair the LPG solenoid control short to ground	Go to Step (6)
6	<ul style="list-style-type: none"> <li>Inspect the ECM wire harness and connector for damage corrosion or contamination</li> </ul> Did you find a problem?		Correct the problem as required. See wire harness repair.	Go to Step (7)
7	<ul style="list-style-type: none"> <li>Replace the ECM</li> </ul> Is the replacement complete?		Go to Step (8)	-
8	<ul style="list-style-type: none"> <li>Remove all test equipment except the DST.</li> <li>Connect any disconnected components, fuses, etc.</li> <li>Using the DST clear DTC information from the ECM.</li> <li>Turn the ignition OFF and wait 30 seconds.</li> <li>Start the engine and operate the vehicle to full operating temperature</li> <li>Observe the MIL</li> <li>Observe engine performance and drivability</li> <li>After operating the engine within the test parameters of DTC-359 check for any stored codes.</li> </ul> Does the engine operate normally with no stored codes?		System OK	Go to OBD System Check

## DTC 420 Gasoline Catalyst Monitor (SPN 3050:FMI 11)

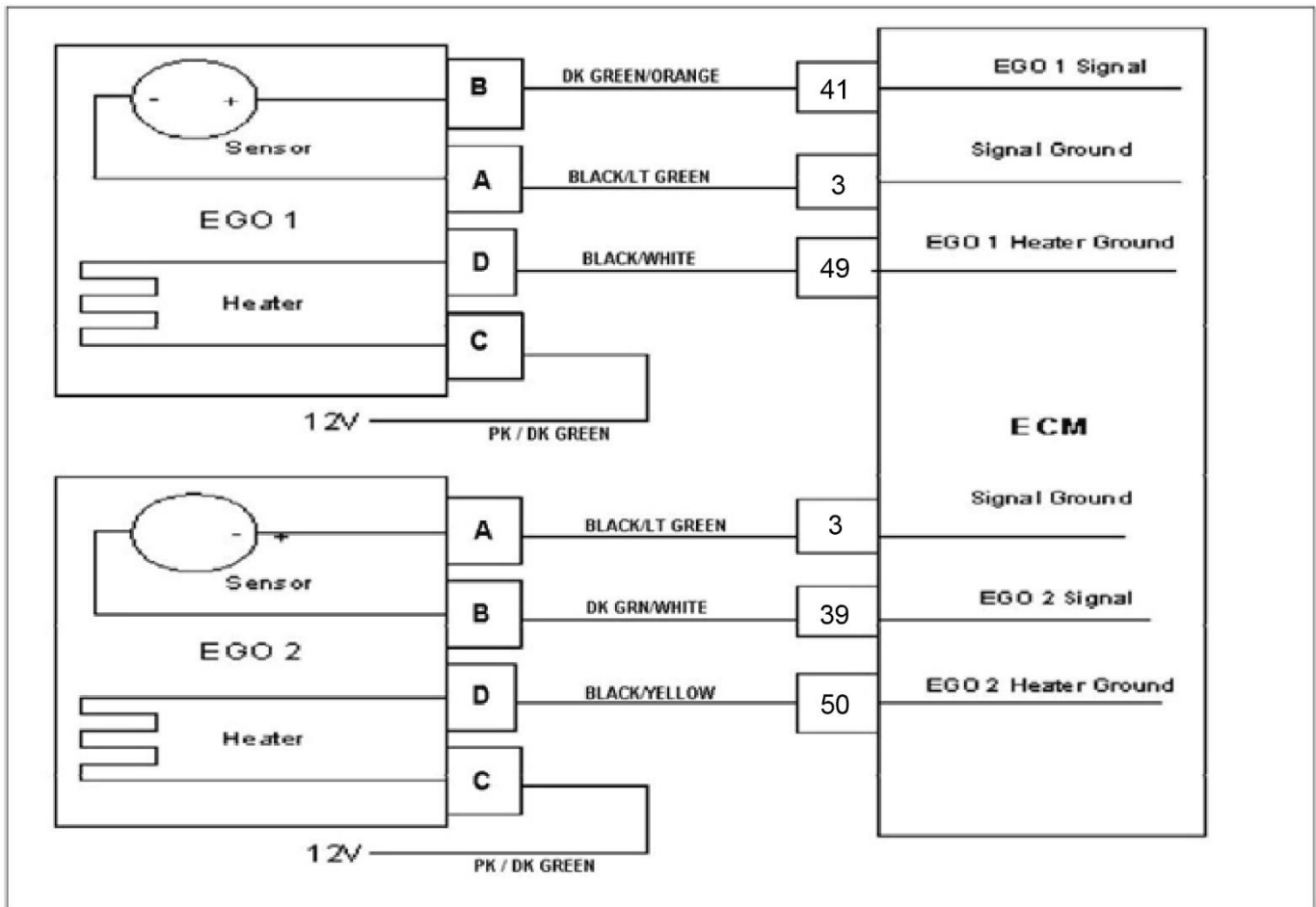

### Conditions for Setting the DTC

- Catalyst Function
- Check condition- Engine running
- Fault condition- EGO 1 signal = EGO 2 signal for 100 updates
- MIL- On during active fault and for 1 second after active fault
- Adaptive- Disabled during active fault

### Circuit Description

The ECM uses EGO 1 and EGO 2 sensor signals to diagnose problems with the catalyst muffler. When the signals for EGO 1 & EGO 2 are similar it may indicate a problem with the catalyst.

### Diagnostic Aids

Always diagnose any other troubles, stored along with DTC 420 first. Check for and eliminate any exhaust leaks prior to replacing catalyst muffler. Look for exhaust leaks at the catalyst muffler inlet and tail pipes. Clear this trouble code after repairing exhaust leaks and recheck for code. If there are no exhaust leaks or other exhaust related issues, there may be a problem internally with the catalyst muffler.



## DTC 502 – Loss of Road Speed (SPN 84:FMI 8)

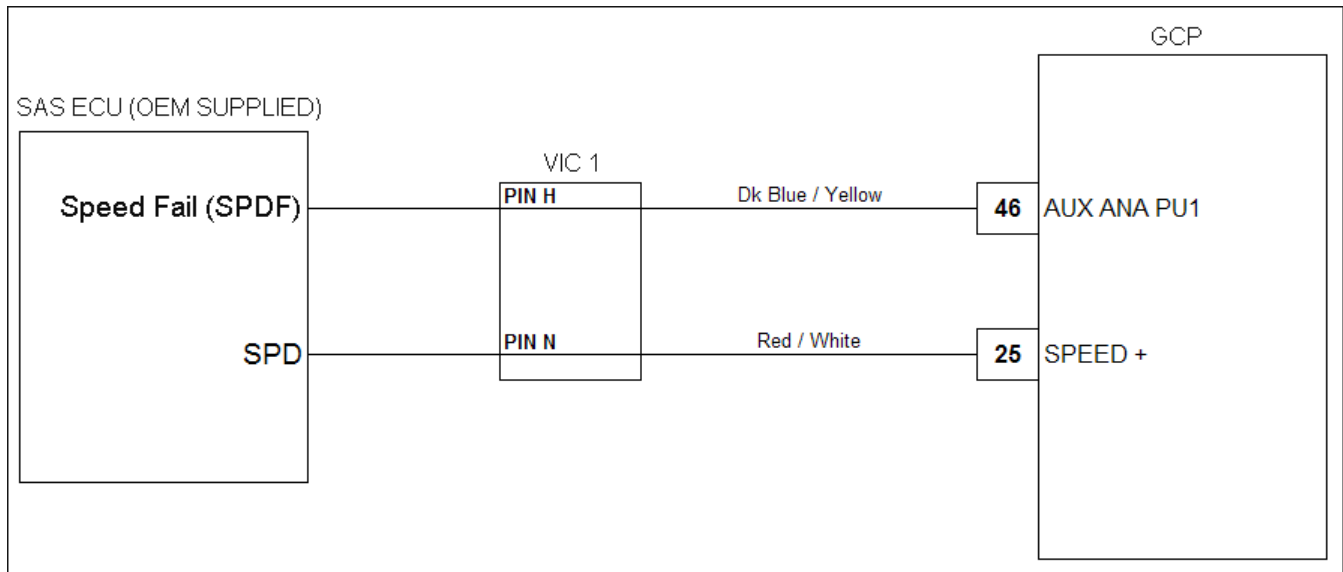

### Conditions for setting the DTC

- Road speed input is less than 0.1 km/hr
- Fault must be active for 5.0 seconds to activate DTC
- Engine speed is greater than 1,500 rpms
- MAP pressure is greater than 10.00 PSIA
- SPDF signal indicates vehicle is moving
- MIL light on during fault
- Power Derate 2 enabled

### Circuit Description

The ECM is provided a pulse width modulation (PWM) signal from the OEM vehicle controller to determine the road speed of the vehicle. The PWM signal is supplied to the engine VIC1 Pin N and finally to pin 25 at the ECM connector. The DTC will set when the PWM signal is lost and the engine speed is greater than 1,500 rpms, MAP pressure is greater than 10.0 psia and the SPDF signal indicates the vehicle is moving. The technician should check the OEM system including vehicle speed controller along with circuit between the vehicle speed controller and the engine ECM.

STEP	Action	Value(s)	Yes	No
1	Did you perform the On-Board (OBD) System Check?	-	Go to Step (2)	Go to OBD System Check Section
2	<ul style="list-style-type: none"> <li>Key Off</li> </ul> Check the wiring for continuity between terminals 25 at the GCP Connector and Pin N of the VIC 1 Do you have continuity between the terminals?	No Resistance	Go to Step (3)	Repair wire circuit between Pin N and Pin 25.
3	<ul style="list-style-type: none"> <li>Check Pin N and Pin 25 for spread terminals or poor connections with the mating terminals.</li> </ul> Are the pins acceptable for use?	-	Go to Step (4)	Repair damaged terminal
4	<ul style="list-style-type: none"> <li>Key off</li> <li>Disconnect battery</li> <li>Install Test GCP</li> <li>Reconnect battery</li> <li>Start engine and check for fault</li> </ul> Did the fault go away?	-	Replace GCP Module	Refer to OEM wiring and/or speed detection system

## DTC 520-Oil Pressure Low Stage 1 (SPN 100:FMI 18)

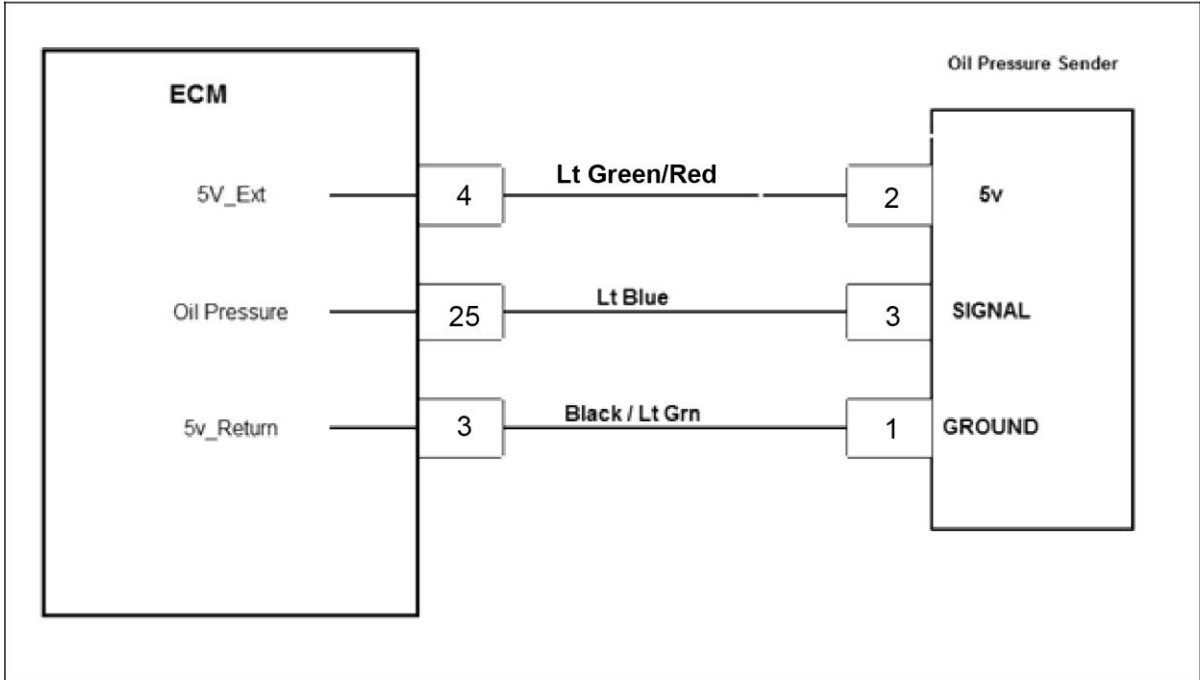

### Conditions for Setting the DTC

- Engine Oil Pressure low.
- Engine running with engine speed less than 1200 rpm and oil pressure is less than 15 psi for 5 or more seconds
- Engine running with engine speed greater than 1450 rpm and oil pressure is less than 20 psi for 5 or more seconds
- MIL is active

### Circuit Description

The Oil Pressure Sender is used to communicate the oil pressure condition to the ECM. Engine damage can occur if the engine is operated with low oil pressure. The ECM sends a 5v signal to the oil pressure sender. The sender will report a signal back to the ECM on the signal wire depending on the pressure that is applied on its diaphragm. The voltage is linear in comparison to the pressure applied (see chart below). The MIL command is ON.

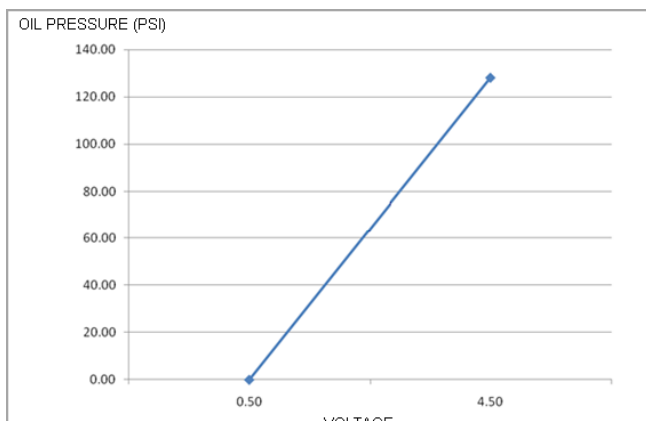

Step	Action	Value(s)	Yes	No
1	Did you perform the On-Board (OBD) System Check?	-	Go to Step (2)	Go to OBD System Check Section
2	<ul style="list-style-type: none"> <li>Verify that the engine has oil pressure using a mechanical oil pressure gauge before proceeding with this chart. See Engine Specifications Section 1F.</li> </ul> Does the engine have oil pressure above 15 psi?	15 psi	Go to Step (3)	Repair faulty Oiling System
3	<ul style="list-style-type: none"> <li>Key ON, Engine Running DST connected in System Data Mode</li> <li>Clear DTC 524</li> <li>Warm the engine by idling until the ECT temperature is above 160 degrees F. and has been running for at least 20 seconds or more</li> <li>Increase engine speed above 600 RPM Does DTC 524 reset and cause the engine to shut down?</li> </ul>		Go to Step (4)	Intermittent problem Go to Intermittent section
4	<ul style="list-style-type: none"> <li>With a voltmeter, check terminal B on the sensor for a 5-volt reference from the ECM.</li> </ul> Do you have 5 volts on terminal 2?	5v	Go to Step (6)	Go to Step (5)
5	<ul style="list-style-type: none"> <li>With a voltmeter, check terminal 4 on the ECM for a 5-volt reference.</li> </ul> Do you have a 5v reference coming out of the ECM?	5v	Repair faulty wiring between ECM and Oil pressure sensor	Go to Step (8)
6	<ul style="list-style-type: none"> <li>With the oil pressure sender connected check for a signal coming out of terminal 3.</li> </ul> Do you have a voltage signal coming out of terminal 3?		Go to Step (7)	Replace faulty oil pressure sender
7	<ul style="list-style-type: none"> <li>With the oil pressure sender connected check for a signal at terminal 25 of the ECM.</li> </ul> Do you have a signal voltage at pin 25 of the ECM?		Go to Step (8)	Repair faulty wiring between terminal 3 and Terminal 25.

Step	Action	Value(s)	Yes	No
8	<ul style="list-style-type: none"> <li>• Replace ECM</li> </ul> Is the replacement complete?		Go to Step (9)	-
9	<ul style="list-style-type: none"> <li>• Remove all test equipment except the DST.</li> <li>• Connect any disconnected components, fuses, etc.</li> <li>• Using the DST clear DTC information from the ECM.</li> <li>• Turn the ignition OFF and wait 30 seconds.</li> <li>• Start the engine and operate the vehicle to full operating temperature</li> <li>• Observe the MIL</li> <li>• Observe engine performance and drivability</li> <li>• After operating the engine within the test parameters of DTC-524 check for any stored codes.</li> </ul> Does the engine operate normally with no stored codes?		System OK	Go to OBD System Check

## DTC 521- Oil Pressure High (SPN 100:FMI 0)

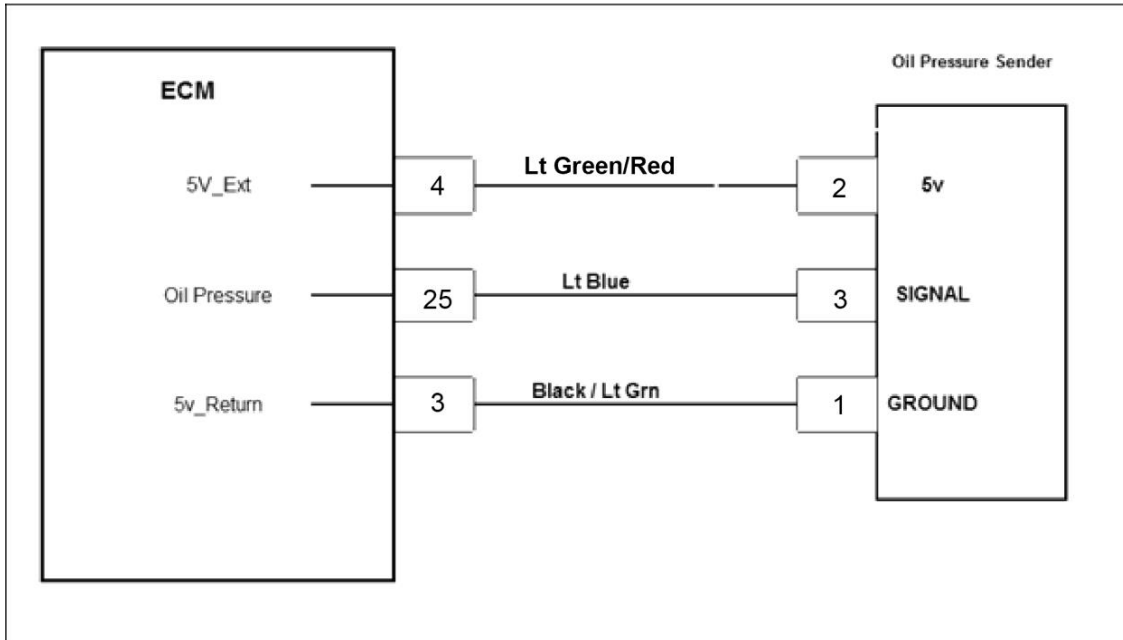

### Conditions for Setting the DTC

- Engine Oil Pressure high.
- Check Condition-Engine running for 5 seconds.
- Fault Condition- Oil pressure greater than 95 psi for 5 or more seconds
- Forced idle is active

### Circuit Description

The Oil Pressure Sender is used to communicate the oil pressure condition to the ECM. Engine damage can occur if the engine is operated with low oil pressure. The ECM sends a 5v signal to the oil pressure sender. The sender will report a signal back to the ECM on the signal wire depending on the pressure that is applied on its diaphragm. The voltage is linear in comparison to the pressure applied (see chart below). The MIL command is ON and the engine will go into a forced idle condition in the event of this fault to help prevent possible engine damage.

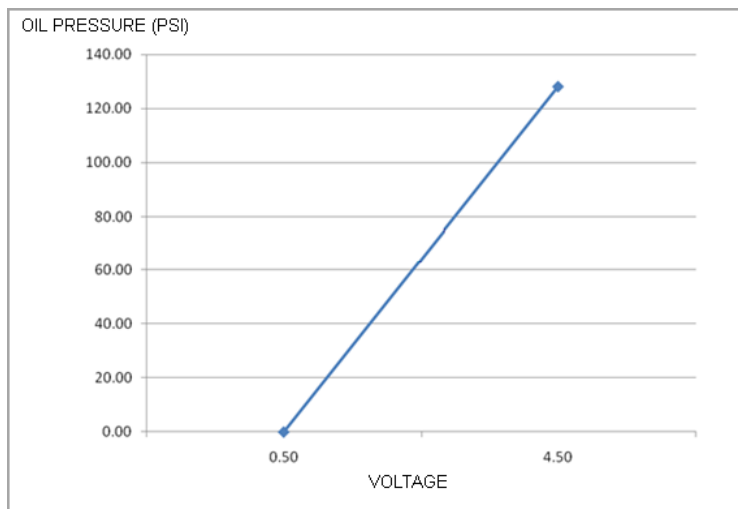

Step	Action	Value(s)	Yes	No
1	Did you perform the On-Board (OBD) System Check?	-	Go to Step (2)	Go to OBD System Check Section
2	<ul style="list-style-type: none"> <li>Verify that the engine has oil pressure using a mechanical oil pressure gauge before proceeding with this chart. See Engine Specifications Section 1F.</li> </ul> Does the engine have oil pressure above 95 psi?		Repair faulty oiling system	Go to step (3)
3	<ul style="list-style-type: none"> <li>With the engine running measure the signal voltage on terminal 3 of the oil pressure sender.</li> </ul> Do you have more than 3.8v?	> 3.8v.	Replace faulty oil pressure sender.	Go to step (4)
4	<ul style="list-style-type: none"> <li>With the engine running measure the signal voltage on terminal 25 of the ECM.</li> </ul> Do you have more than 3.8v?	> 3.8v.	Repair faulty wiring between terminal 3 and 25.	Replace faulty IEPR / ECM

## DTC 522- Oil Pressure Sender low voltage (SPN 100:FMI 4)

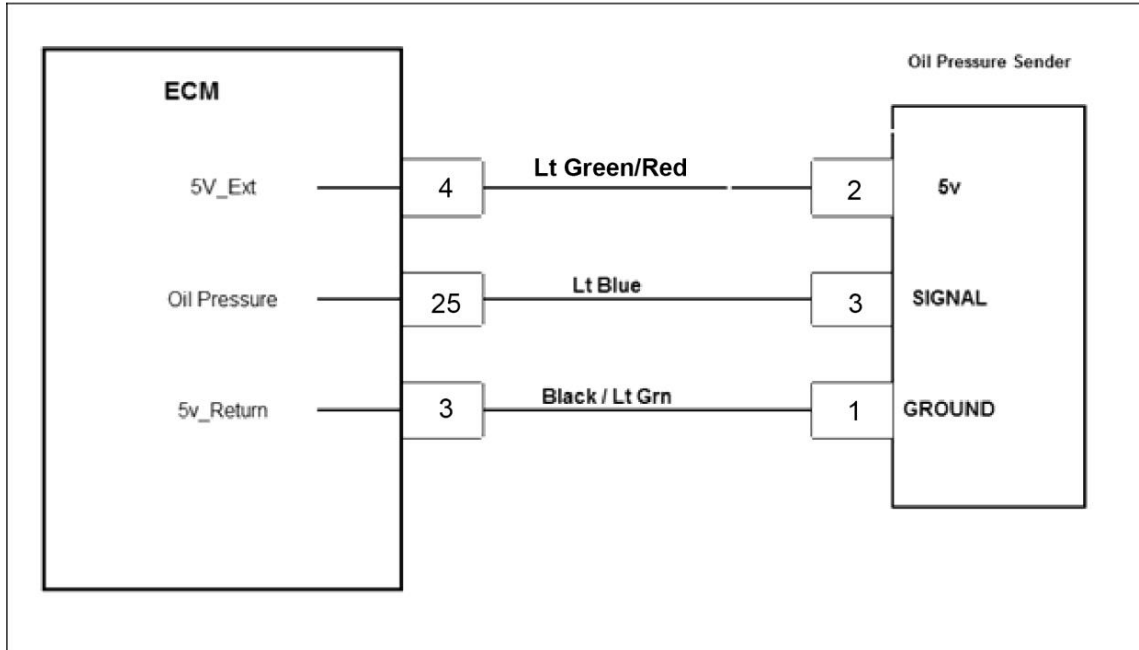

### Conditions for Setting the DTC

- Engine Oil Pressure low.
- Check Condition-Engine running for 20 seconds or more with engine speed greater than 600 rpm.
- Fault Condition- Voltage on terminal 25 is less than 0.2v for more than 1 second
- MIL-ON during active fault and for 2 seconds after active fault.
- Forced idle active

### Circuit Description

The Oil Pressure Sender is used to communicate the oil pressure condition to the ECM. Engine damage can occur if the engine is operated with low oil pressure. The ECM sends a 5v signal to the oil pressure sender. The sender will report a signal back to the ECM on the signal wire depending on the pressure that is applied on its diaphragm. The voltage is linear in comparison to the pressure applied (see chart below). The MIL command is ON and the engine will go into a forced idle in the event of this fault to help prevent possible engine damage.

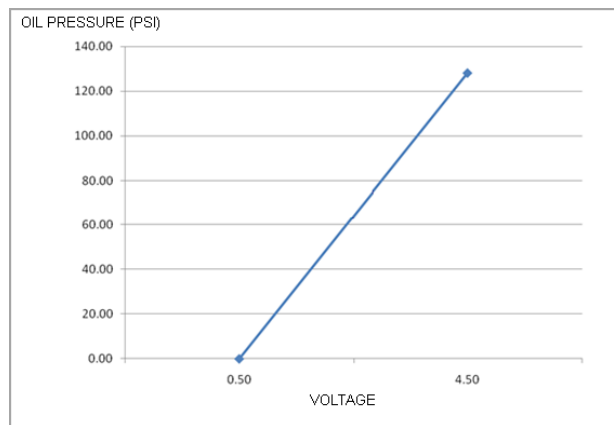



Step	Action	Value(s)	Yes	No
1	Did you perform the On-Board (OBD) System Check?	-	Go to Step (2)	Go to OBD System Check Section
2	<ul style="list-style-type: none"> <li>Using the Diagnostic Service Tool (DST) with the key on engine running, check the OILP_raw value on the "RAW VOLTS" page.</li> </ul> <p>Is the voltage less than 0.2 volts</p>	< 0.2v	Go to Step (3)	Check for faulty harness or intermittent ECM issue.
3	<ul style="list-style-type: none"> <li>Using a voltmeter measure the voltage at terminal 53 of the ECM</li> <li>Key on engine running</li> </ul> <p>Is the voltage less than 0.2 volts?</p>	< 0.2v	Go to Step (4)	Replace faulty ECM
4	<ul style="list-style-type: none"> <li>Key on engine running</li> <li>Check for the voltage supply signal to the oil pressure switch at terminal 2 of the pressure switch.</li> </ul> <p>Does the terminal have 5 volts?</p>	5v	Go to step (4)	Go to step (6)
5	<ul style="list-style-type: none"> <li>Using a voltmeter measure the voltage at terminal 3 at the oil pressure sender.</li> <li>Key on engine running</li> </ul> <p>Is the voltage less than 0.2 volts?</p>	< 0.2v	Replace faulty oil pressure sender.	Intermittent problem, go to intermittent section
6	<ul style="list-style-type: none"> <li>Key on</li> <li>Check for voltage supply signal at terminal 4 of the ECM</li> </ul> <p>Does the ECM terminal 4 provide a 5v signal?</p>	5v	Replace ECM.	Repair wiring issue between pin 4 and oil pressure sender terminal 2

## DTC 523- Oil Pressure Sender high voltage (SPN 100:FMI 3)

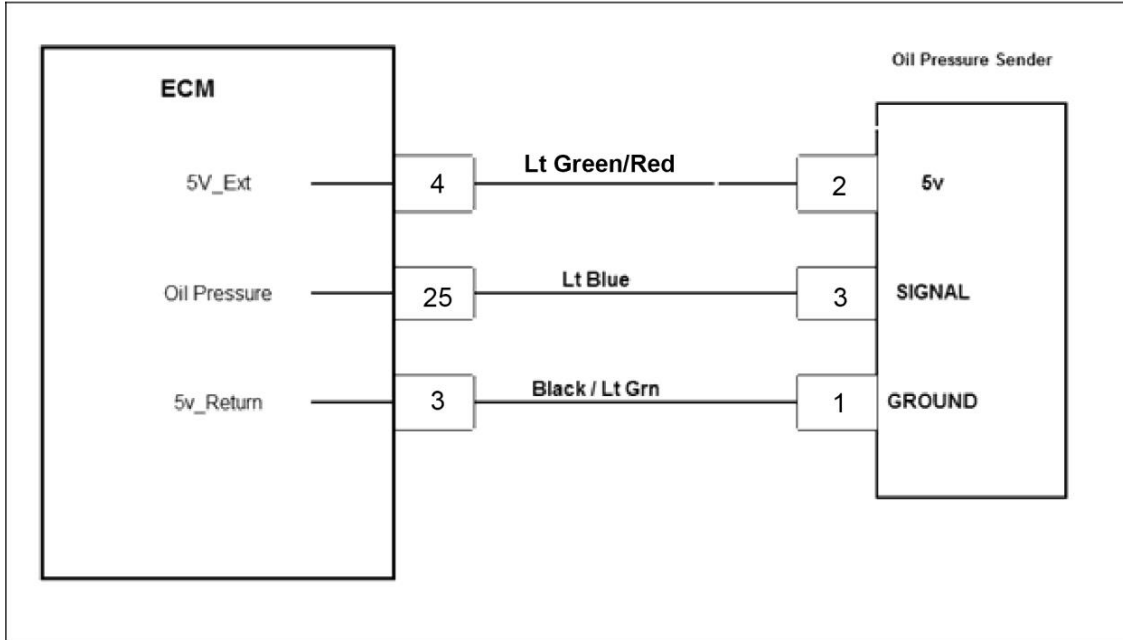

### Conditions for Setting the DTC

- Engine Oil Pressure sender voltage is high
- Check Condition-Engine running for 20 seconds or more with engine speed greater than 600 rpm.
- Fault Condition- Voltage on terminal 25 is greater than 4.8v for more than 1 second
- MIL-ON during active fault and for 2 seconds after active fault.
- Forced idle active

### Circuit Description

The Oil Pressure Sender is used to communicate the oil pressure condition to the ECM. Engine damage can occur if the engine is operated with low oil pressure. The ECM sends a 5v signal to the oil pressure sender. The sender will report a signal back to the ECM on the signal wire depending on the pressure that is applied on its diaphragm. The voltage is linear in comparison to the pressure applied (see chart below). The MIL command is ON and the engine will go into forced idle in the event of this fault to help prevent possible engine damage.

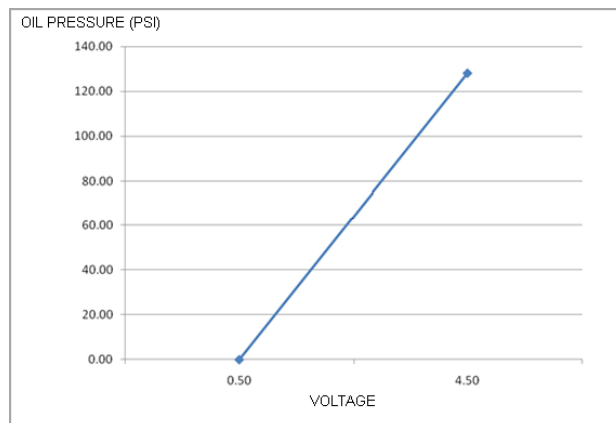

Step	Action	Value(s)	Yes	No
1	Did you perform the On-Board (OBD) System Check?	-	Go to Step (2)	Go to OBD System Check Section
2	<ul style="list-style-type: none"> <li>Using the Diagnostic Service Tool (DST) check the OILP_raw value on the "RAW VOLTS" page.</li> </ul> Is the voltage over 4.8 volts	> 4.8v	Go to Step (3)	Check for faulty harness or intermittent ECM issue
3	<ul style="list-style-type: none"> <li>Using a voltmeter measure the voltage at terminal 25 of the ECM</li> </ul> Is the voltage over 4.8 volts?	> 4.8v	Go to Step (4)	Replace faulty IEPR / ECM
4	<ul style="list-style-type: none"> <li>Using a voltmeter measure the voltage at terminal 3 at the oil pressure sender.</li> </ul> Is the voltage over 4.8 volts?	> 4.8v	Replace faulty oil pressure sender.	Intermittent problem, go to intermittent section

## DTC 524-Oil Pressure Low Stage 2 (SPN 100:FMI 1)

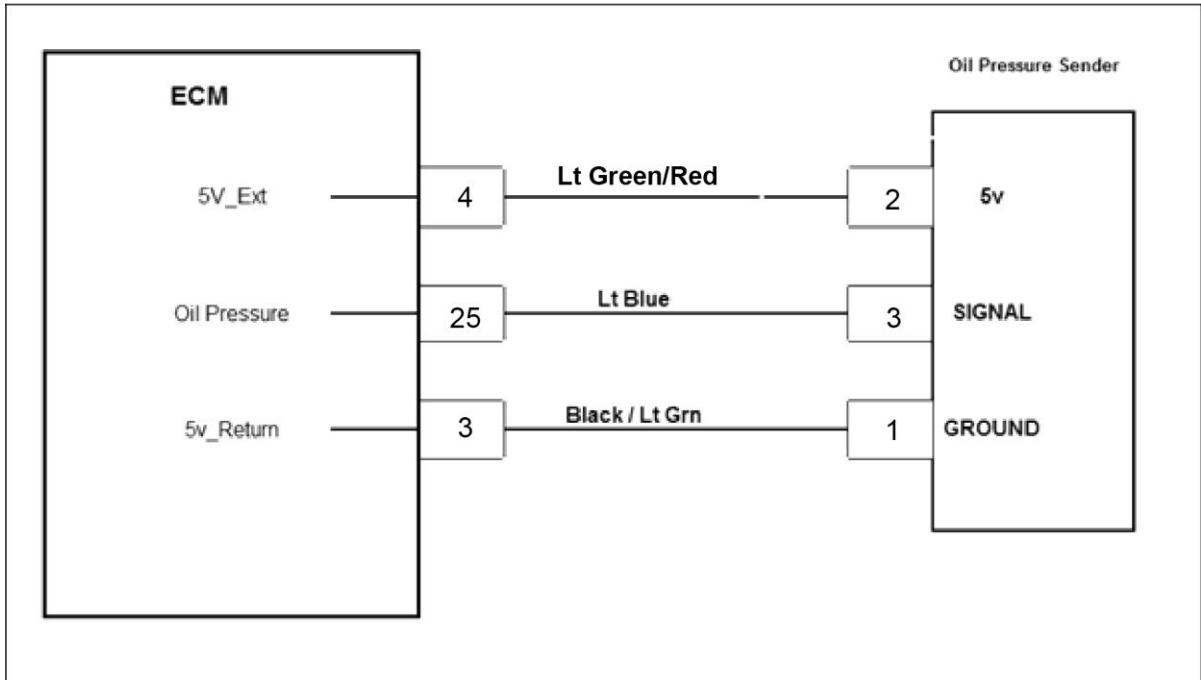

### Conditions for Setting the DTC

- Engine Oil Pressure low.
- Fault Condition- Oil pressure less than 8 psi for 5 or more seconds
- Engine Shut Down.

### Circuit Description

The Oil Pressure Sender is used to communicate the oil pressure condition to the ECM. Engine damage can occur if the engine is operated with low oil pressure. The ECM sends a 5v signal to the oil pressure sender. The sender will report a signal back to the ECM on the signal wire depending on the pressure that is applied on its diaphragm. The voltage is linear in comparison to the pressure applied (see chart below). The MIL command is ON and the engine will shut down in the event of this fault to help prevent possible engine damage.

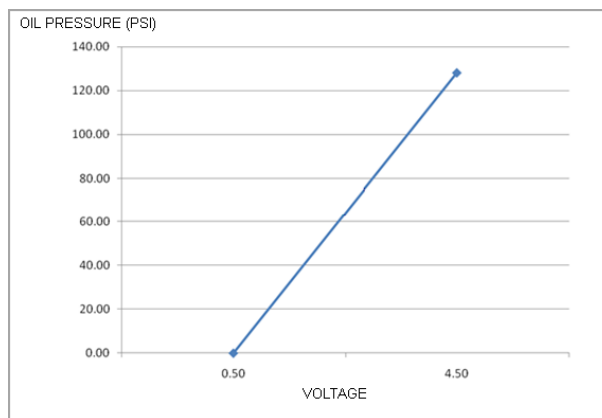

Step	Action	Value(s)	Yes	No
1	Did you perform the On-Board (OBD) System Check?	-	Go to Step (2)	Go to OBD System Check Section
2	<ul style="list-style-type: none"> <li>Verify that the engine has oil pressure using a mechanical oil pressure gauge before proceeding with this chart. See Engine Specifications Section 1F.</li> </ul> Does the engine have oil pressure above 8 psi?	8 psi	Go to Step (3)	Repair faulty Oiling System
3	<ul style="list-style-type: none"> <li>Key ON, Engine Running DST connected in System Data Mode</li> <li>Clear DTC 524</li> <li>Warm the engine by idling until the ECT temperature is above 160 degrees F. and has been running for at least 20 seconds or more</li> <li>Increase engine speed above 600 RPM Does DTC 524 reset and cause the engine to shut down?</li> </ul>		Go to Step (4)	Intermittent problem Go to Intermittent section
4	<ul style="list-style-type: none"> <li>With a voltmeter, check terminal 2 on the sensor for a 5-volt reference from the ECM.</li> </ul> Do you have 5 volts on terminal 2?	5v	Go to Step (6)	Go to Step (5)
5	<ul style="list-style-type: none"> <li>With a voltmeter, check terminal 4 on the ECM for a 5-volt reference.</li> </ul> Do you have a 5v reference coming out of the ECM?	5v	Repair faulty wiring between ECM and Oil pressure sensor	Go to Step (8)
6	<ul style="list-style-type: none"> <li>With the oil pressure sender connected check for a signal coming out of terminal 3.</li> </ul> Do you have a voltage signal coming out of terminal 3?	See Linear graph on page 207 for expected approx. Voltage	Go to Step (7)	Replace faulty oil pressure sender
7	<ul style="list-style-type: none"> <li>With the oil pressure sender connected check for a signal at terminal 25 of the ECM.</li> </ul> Do you have a signal voltage at pin 25 of the ECM?		Go to Step (8)	Repair faulty wiring between terminal 3 and Terminal 25.

Step	Action	Value(s)	Yes	No
8	<ul style="list-style-type: none"> <li>• Replace ECM</li> </ul> Is the replacement complete?		Go to Step (9)	-
9	<ul style="list-style-type: none"> <li>• Remove all test equipment except the DST.</li> <li>• Connect any disconnected components, fuses, etc.</li> <li>• Using the DST clear DTC information from the ECM.</li> <li>• Turn the ignition OFF and wait 30 seconds.</li> <li>• Start the engine and operate the vehicle to full operating temperature</li> <li>• Observe the MIL</li> <li>• Observe engine performance and drivability</li> <li>• After operating the engine within the test parameters of DTC-524 check for any stored codes.</li> </ul> Does the engine operate normally with no stored codes?		System OK	Go to OBD System Check

## DTC 562-System Voltage Low (SPN 168:FMI 17)

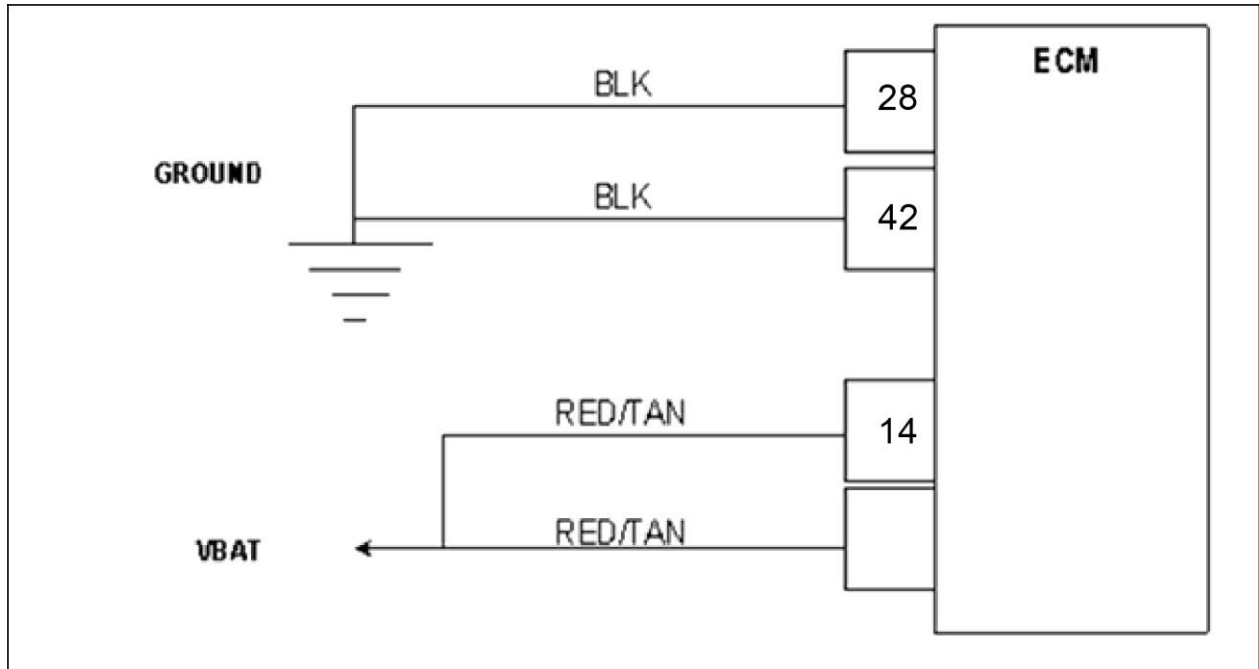

### Conditions for Setting the DTC

- System Voltage to ECM
- Check Condition-Key on with engine speed greater than 1000 RPM
- Fault Condition-Battery voltage at ECM less than 9.0
- Fault Condition is present for longer than 5 seconds.
- MIL-ON for active fault
- Adaptive-Disabled

### Circuit Description

The battery voltage powers the ECM and must be measured to correctly to properly operate injector drivers, solenoid valves and ignition coils. This fault will set if the ECM detects system voltage less than 9.00 volts while the alternator should be charging. The adaptive learn is disabled during this fault.

Step	Action	Value(s)	Yes	No
1	Did you perform the On-Board (OBD) System Check?	-	Go to Step (2)	Go to OBD System Check Section
2	<ul style="list-style-type: none"> <li>Key ON, Engine Running</li> <li>DST (Diagnostic Scan Tool) connected in System Data Mode</li> </ul> Does DST display system voltage greater than 9.50 volts?	-	Intermittent problem Go to Engine Electrical Intermittent section	Go to Step (3)
3	<ul style="list-style-type: none"> <li>Check battery condition</li> </ul> Is it OK?	-	Go to Step (4)	Replace Battery
4	<ul style="list-style-type: none"> <li>Check charging system</li> </ul> Is it OK?	-	Go to Step (5)	Repair charging System
5	<ul style="list-style-type: none"> <li>Key OFF</li> <li>Disconnect the ECM connector C001</li> <li>Check the voltage between ECM connector C001 pins 60, 79 and engine ground.</li> <li>Measure voltage with DVOM between each pin and engine ground</li> </ul> Is the voltage greater than for each pin 9.50 volts?	-	Repair ECM Ground circuit. Go to Power and Ground section in engine Electrical	Go to Step (6)
6	<ul style="list-style-type: none"> <li>Check the voltage at ECM connector pins 69 and 81</li> <li>Measure voltage with DVOM between each pin and battery positive</li> </ul> Is the voltage greater than 9.50 volts?	-	Repair ECM power circuit. Go to Power and Ground section in engine Electrical	Go to Step (7)
7	<ul style="list-style-type: none"> <li>Replace ECM</li> </ul> Is the replacement complete?	-	Go to Step (8)	-
8	<ul style="list-style-type: none"> <li>Remove all test equipment except the DST.</li> <li>Connect any disconnected components, fuses, etc.</li> <li>Using the DST clear DTC information from the ECM.</li> <li>Turn the ignition OFF and wait 30 seconds.</li> <li>Start the engine and operate the vehicle to full operating temperature</li> <li>Observe the MIL</li> <li>Observe engine performance and drivability</li> <li>After operating the engine within the test parameters of DTC-562 check for any stored codes.</li> </ul> Does the engine operate normally with no stored codes?	-	System OK	Go to OBD System Check



## DTC 563-System Voltage High (SPN 168:FMI 15)

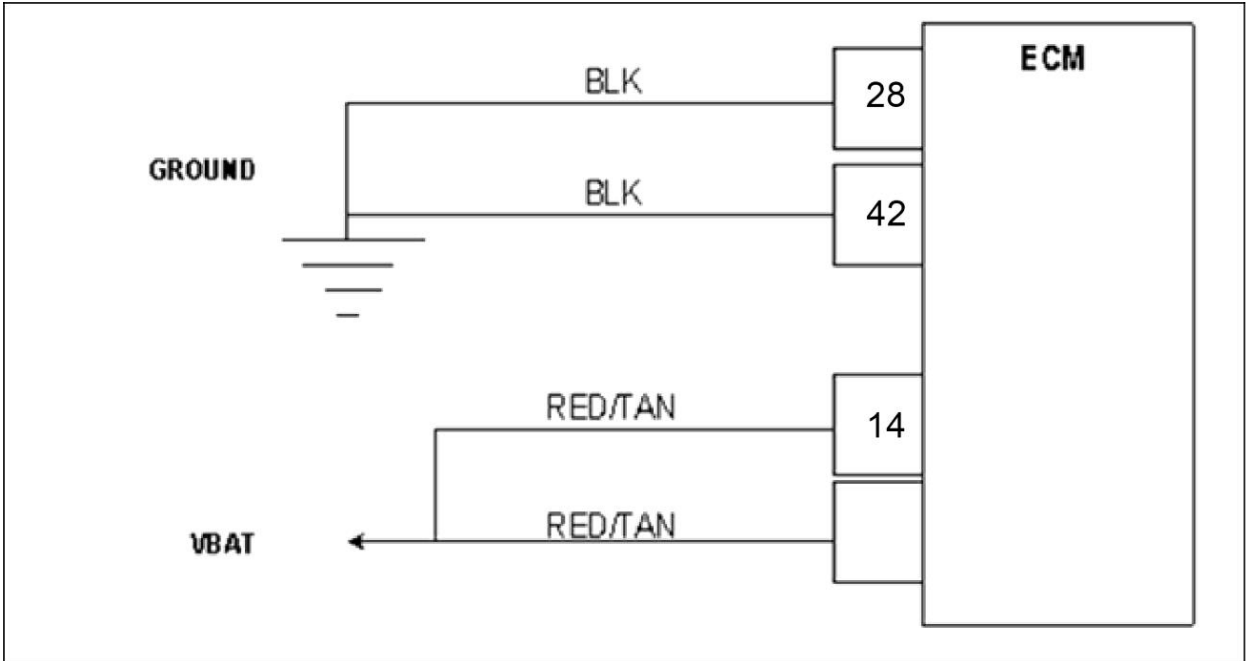

### Conditions for Setting the DTC

- System Voltage to ECM
- Check Condition-Cranking or Running
- Fault Condition-System battery voltage at ECM greater than 18 volts
- Fault must be present for 3 or more seconds
- MIL-ON for active fault
- Adaptive-Disabled

### Circuit Description

The battery voltage powers the ECM and must be measured to correctly operate injector drivers, trim valves, and ignition coils. This fault will set if the ECM detects voltage greater than 18 volts anytime the engine is cranking or running. The adaptive learn function is disabled during this fault. The ECM will shut down with internal protection if the system voltage ever exceeds 26 volts.

Step	Action	Value(s)	Yes	No
1	Did you perform the On-Board (OBD) System Check?	-	Go to Step (2)	Go to OBD System Check Section
2	<ul style="list-style-type: none"> <li>Key ON, Engine Running</li> <li>DST (Diagnostic Scan Tool) connected in System Data Mode</li> <li>Run engine greater than 1500 rpm.</li> </ul> Does DST display system voltage greater than 18 volts?	-	Go To Step (3)	Intermittent problem Go to Engine Electrical Intermittent section
3	<ul style="list-style-type: none"> <li>Check voltage at battery terminals with DVOM with engine speed greater than 1500rpm</li> </ul> Is it greater than 18 volts?	-	Go to Step (4)	Go to Step (5)
4	<ul style="list-style-type: none"> <li>Repair the charging system</li> </ul> Has the charging system been repaired?	-	Go to Step (6)	-
5	<ul style="list-style-type: none"> <li>Replace ECM</li> </ul> Is the replacement complete?	-	Go to Step (6)	-
6	<ul style="list-style-type: none"> <li>Remove all test equipment except the DST.</li> <li>Connect any disconnected components, fuses, etc.</li> <li>Using the DST clear DTC information from the ECM.</li> <li>Turn the ignition OFF and wait 30 seconds.</li> <li>Start the engine and operate the vehicle to full operating temperature</li> <li>Observe the MIL</li> <li>Observe engine performance and drivability</li> <li>After operating the engine within the test parameters of DTC-563 check for any stored codes.</li> </ul> Does the engine operate normally with no stored codes?	-	System OK	Go to OBD System Check

## **DTC 601-Flash Checksum Invalid (SPN 628:FMI 13)**

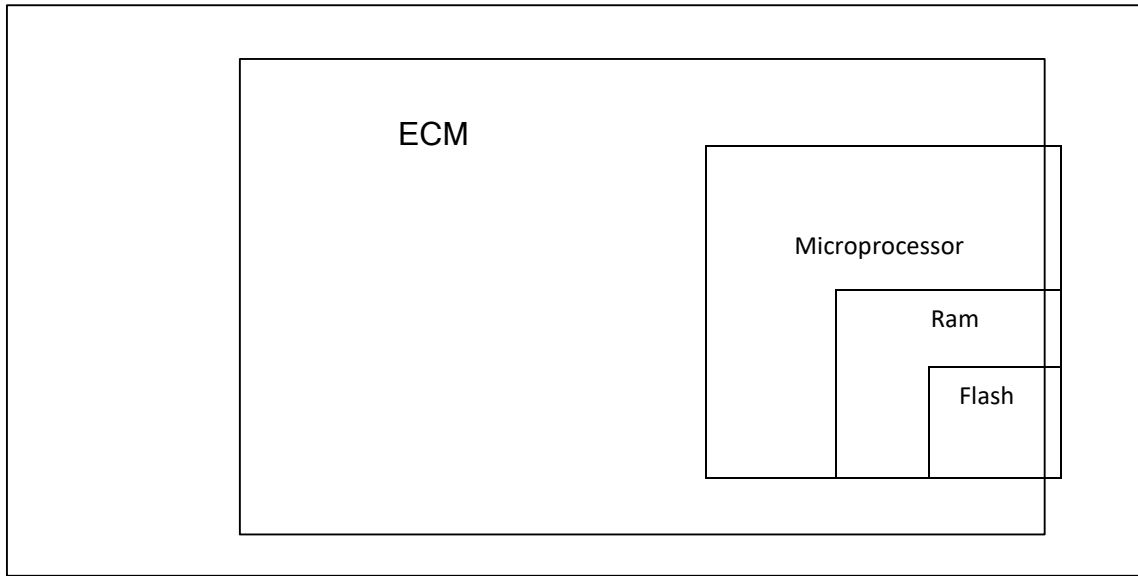

### **Conditions for Setting the DTC**

- Engine Control Module
- Check Condition-Key on
- Fault Condition-Internal microprocessor error
- MIL-ON
- Engine Shutdown will occur

### **Circuit Description**

The ECM has several internal checks that must be satisfied each time an instruction is executed. Several different things can happen within the microprocessor that will cause this fault. The ECM will attempt to reset itself in the event this fault is set. The MIL command is on and will remain on until the code is cleared using the DST. The engine will shut down when this fault occurs.

Step	Action	Value(s)	Yes	No
1	Did you perform the On-Board (OBD) System Check?	-	Go to Step (2)	Go to OBD System Check Section
2	<ul style="list-style-type: none"> <li>Key ON, Engine Running</li> <li>DST (Diagnostic Scan Tool) connected in System Data Mode</li> <li>Clear system fault code</li> </ul> Does DTC 601 reset with the engine idling?		Go to Step (3)	Intermittent problem Go to Intermittent section
3	<ul style="list-style-type: none"> <li>Check ECM power and ground circuits Did the power and ground circuits check OK?</li> </ul>		Go to Step (4)	Repair the circuit as necessary. Refer to Wiring Repairs in Engine Electrical.
4	<ul style="list-style-type: none"> <li>Replace ECM</li> </ul> Is the replacement complete?		Go to Step (5)	-
5	<ul style="list-style-type: none"> <li>Remove all test equipment except the DST.</li> <li>Connect any disconnected components, fuses, etc.</li> <li>Using the DST clear DTC information from the ECM.</li> <li>Turn the ignition OFF and wait 30 seconds.</li> <li>Start the engine and operate the vehicle to full operating temperature</li> <li>Observe the MIL</li> <li>Observe engine performance and drivability</li> <li>After operating the engine within the test parameters of DTC-601 check for any stored codes.</li> </ul> Does the engine operate normally with no stored codes?		System OK	Go to OBD System Check

## **DTC 604-RAM Failure (SPN 630:FMI 12)**

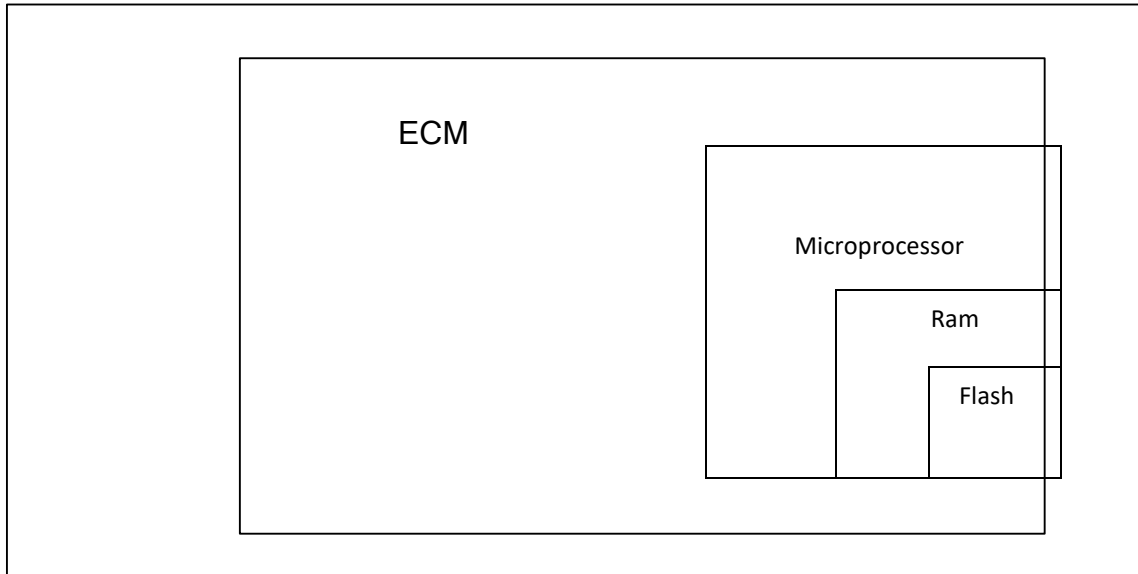

### **Conditions for Setting the DTC**

- Engine Control Module
- Check Condition-Key on
- Fault Condition-Internal microprocessor error
- MIL-ON
- Engine Shutdown will occur

### **Circuit Description**

The ECM has several internal checks that must be satisfied each time an instruction is executed. Several different things can happen within the microprocessor that will cause this fault. The ECM will attempt to reset itself in the event this fault is set. The MIL command is on and will remain on until the code is cleared using the DST. The engine will shut down if this fault occurs.

Step	Action	Value(s)	Yes	No
1	Did you perform the On-Board (OBD) System Check?	-	Go to Step (2)	Go to OBD System Check Section
2	<ul style="list-style-type: none"> <li>• Key ON, Engine Running</li> <li>• DST (Diagnostic Scan Tool) connected in System Data Mode</li> <li>• Clear system fault code</li> </ul> Does DTC 604 reset with the engine idling?		Go to Step (3)	Intermittent problem Go to Intermittent section
3	<ul style="list-style-type: none"> <li>• Check ECM power and ground circuits Did the power and ground circuits check OK?</li> </ul>		Go to Step (4)	Repair the circuit as necessary. Refer to Wiring Repairs in Engine Electrical.
4	<ul style="list-style-type: none"> <li>• Replace ECM</li> </ul> Is the replacement complete?		Go to Step (5)	-
5	<ul style="list-style-type: none"> <li>• Remove all test equipment except the DST.</li> <li>• Connect any disconnected components, fuses, etc.</li> <li>• Using the DST clear DTC information from the ECM.</li> <li>• Turn the ignition OFF and wait 30 seconds.</li> <li>• Start the engine and operate the vehicle to full operating temperature</li> <li>• Observe the MIL</li> <li>• Observe engine performance and drivability</li> <li>• After operating the engine within the test parameters of DTC-604 check for any stored codes.</li> </ul> Does the engine operate normally with no stored codes?		System OK	Go to OBD System Check

## **DTC 606-COP Failure (SPN 629:FMI 31)**

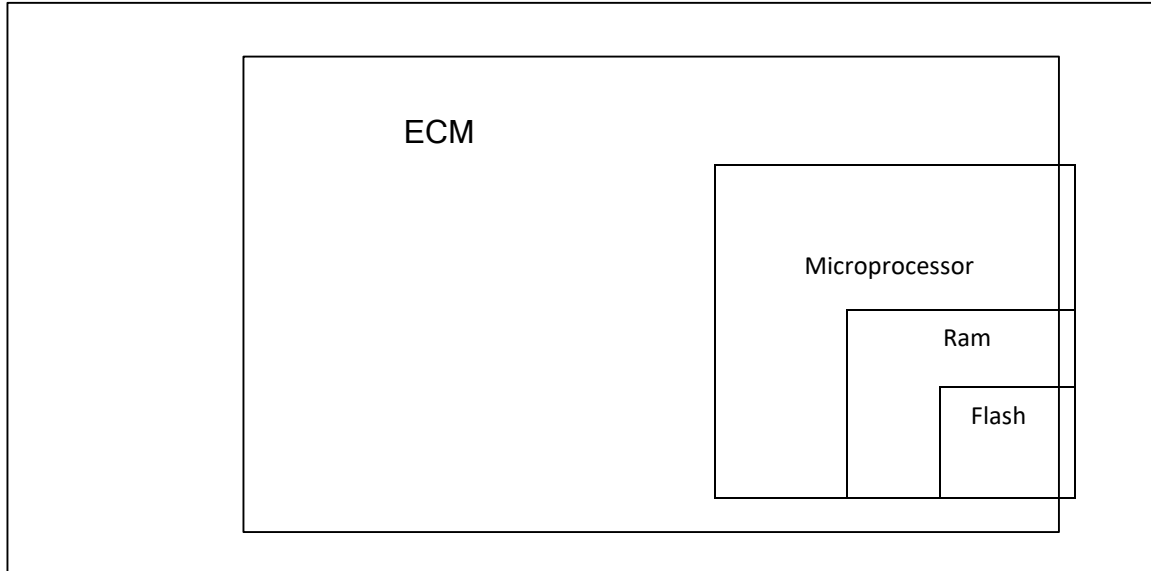

### **Conditions for Setting the DTC**

- Engine Control Module
- Check Condition-Key on
- Fault Condition-Internal microprocessor error
- MIL-ON
- Engine Shutdown will occur

### **Circuit Description**

The ECM has several internal checks that must be satisfied each time an instruction is executed. Several different things can happen within the microprocessor that will cause this fault. The ECM will attempt to reset itself in the event this fault is set. The MIL command is on and will remain on until the code is cleared using the DST. The engine will shut down if this fault occurs.

Step	Action	Value(s)	Yes	No
1	Did you perform the On-Board (OBD) System Check?	-	Go to Step (2)	Go to OBD System Check Section
2	<ul style="list-style-type: none"> <li>Key ON, Engine Running</li> <li>DST (Diagnostic Scan Tool) connected in System Data Mode</li> <li>Clear system fault code</li> </ul> Does DTC 606 reset with the engine idling?		Go to Step (3)	Intermittent problem Go to Intermittent section
3	<ul style="list-style-type: none"> <li>Check ECM power and ground circuits Are the power and ground circuits, OK?</li> </ul>		Go to Step (4)	Repair the circuit as necessary. Refer to Wiring Repairs in Engine Electrical.
4	<ul style="list-style-type: none"> <li>Replace ECM</li> </ul> Is the replacement complete?		Go to Step (5)	-
5	<ul style="list-style-type: none"> <li>Remove all test equipment except the DST.</li> <li>Connect any disconnected components, fuses, etc.</li> <li>Using the DST clear DTC information from the ECM.</li> <li>Turn the ignition OFF and wait 30 seconds.</li> <li>Start the engine and operate the vehicle to full operating temperature</li> <li>Observe the MIL</li> <li>Observe engine performance and drivability</li> <li>After operating the engine within the test parameters of DTC-606 check for any stored codes.</li> </ul> Does the engine operate normally with no stored codes?		System OK	Go to OBD System Check



## DTC 627-Fuel Pump Relay Coil Open (SPN 1348:FMI 5)

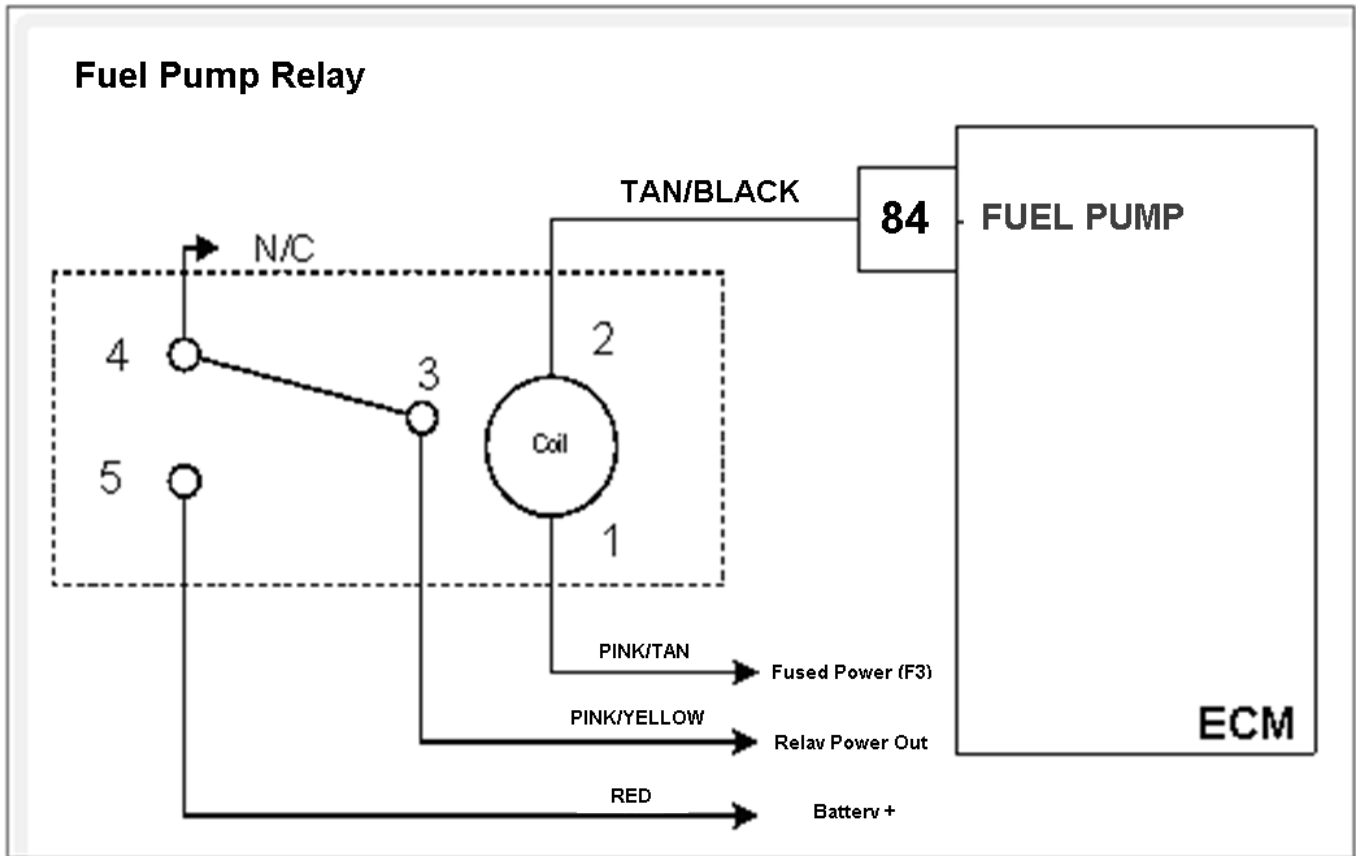

### Conditions for Setting the DTC

- Fuel Pump relay check
- Check Condition-Key ON
- Fault Condition-Relay coil open

### Circuit Description

The fuel pump relay switches power out to the gasoline fuel pump. This fault will set if the ECM detects an open circuit on the relay control output.

### Diagnostic Aid

Relay coil resistance changes with temperature. The following diagnostic charts have steps to measure relay coil resistance values. When checking the resistance values be sure the relay is at a reasonable temperature, between +20- and +100-degrees F.

Step	Action	Value(s)	Yes	No
1	Did you perform the On-Board (OBD) System Check?	-	Go to Step (2)	Go to OBD System Check Section
2	<ul style="list-style-type: none"> <li>DST connected and in the system data mode</li> <li>Key OFF</li> <li>Remove the power relay from the fuse block</li> <li>Using a DVOM check the resistance of the relay coil between terminals 1 and 2</li> </ul> Is the resistance value less than 100 ohms?		Go to Step (4)	Go to Step (3)
3	<ul style="list-style-type: none"> <li>Replace the fuel pump relays</li> </ul> the replacement complete?		Go to Step (9)	-
4	<ul style="list-style-type: none"> <li>Check fuse F3Is</li> </ul> the fuse open?		Replace fuse F2	Go to Step (5)
5	<ul style="list-style-type: none"> <li>Disconnect ECM connector C001</li> <li>Using a DVOM check for continuity between ECM pin 84 and fuse block cavity for relay terminal 2</li> </ul> Do you have continuity?		Go to Step (6)	Repair the open circuit as required. See wiring harness repairs
6	<ul style="list-style-type: none"> <li>Remove fuse F3</li> <li>Using a DVOM check for continuity between fuse block cavity for relay terminal 1 and the power out of the F3 fuse holder</li> </ul> Do you have continuity?		Go to Step (7)	Repair the open circuit as required. See wiring harness repairs
7	<ul style="list-style-type: none"> <li>Check all system fuses.</li> <li>Check all relay placement positions in fuse block.</li> <li>Run complete pin to pin checks on chassis wiring to fuel system harness.</li> <li>See complete fuel system schematic for further details</li> </ul> Did you find the problem?		Go to Step (9)	Go to Step (8)

Step	Action	Value(s)	Yes	No
8	<ul style="list-style-type: none"> <li>Replace the ECM</li> </ul> Is the replacement complete?		Go to Step (9)	–
9	<ul style="list-style-type: none"> <li>Remove all test equipment except the DST.</li> <li>Connect any disconnected components, fuses, etc.</li> <li>Using the DST clear DTC information from the ECM.</li> <li>Turn the ignition OFF and wait 30 seconds.</li> <li>Start the engine and operate the vehicle to full operating temperature</li> <li>Observe the MIL</li> <li>Observe engine performance and drivability</li> <li>After operating the engine within the test parameters of DTC-627 check for any stored codes.</li> </ul> Does the engine operate normally with no stored codes?		System OK	Go to OBD System Check

## DTC 628- Fuel Pump Relay Control Ground Short (SPN 1348:FMI 4)

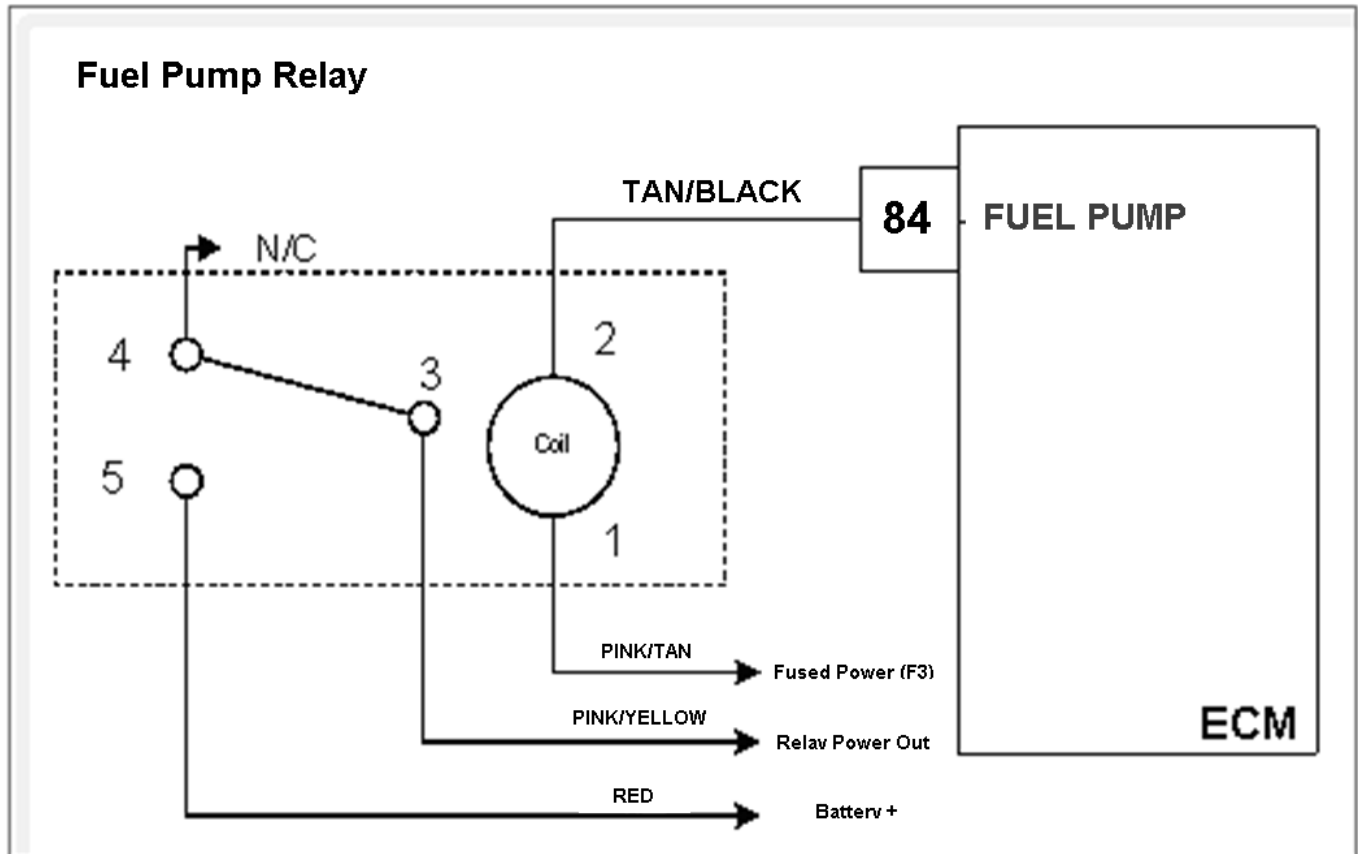

### Conditions for Setting the DTC

- Fuel Pump relay ground control
- Check Condition-Key ON
- Fault Condition-Relay control shorted to ground

### Circuit Description

The fuel pump relay switches power out to the gasoline fuel pump. This fault will set if the ECM detects an open circuit on the relay control output.

### Diagnostic Aid

Relay coil resistance changes with temperature. The following diagnostic charts have steps to measure relay coil resistance values. When checking the resistance values be sure the relay is at a reasonable temperature, between +20- and +100-degrees F.

Step	Action	Value(s)	Yes	No
1	Did you perform the On-Board (OBD) System Check?	-	Go to Step (2)	Go to OBD System Check Section
2	<ul style="list-style-type: none"> <li>Key ON, DST connected in the System Data mode</li> <li>Clear DTC 628</li> <li>Start the engine</li> </ul> Does DTC 628 re-set?		Go to Step (4)	Intermittent problem Go to Intermittent section
3	<ul style="list-style-type: none"> <li>Disconnect ECM connector C001</li> <li>Using a DVOM check the resistance value between ECM pin 84 and engine ground</li> </ul> Is the resistance less than 60 ohms?		Go to Step (5)	Go to Step (7)
4	<ul style="list-style-type: none"> <li>Remove the fuel pump relay from the fuse block</li> <li>Using a DVOM check the resistance value again between ECM pin 84 and engine ground</li> </ul> Is the resistance less than 60 ohms?		Repair the shorted to ground relay control circuit as necessary. See wiring harness repairs	Go to Step (6)
5	<ul style="list-style-type: none"> <li>Replace the fuel pump relays</li> </ul> Is the replacement complete?		Go to Step (8)	-
6	<ul style="list-style-type: none"> <li>Replace ECM</li> </ul> Is the replacement complete?		Go to Step (8)	-
7	<ul style="list-style-type: none"> <li>Remove all test equipment except the DST.</li> <li>Connect any disconnected components, fuses, etc.</li> <li>Using the DST clear DTC information from the ECM.</li> <li>Turn the ignition OFF and wait 30 seconds.</li> <li>Start the engine and operate the vehicle to full operating temperature</li> <li>Observe the MIL</li> <li>Observe engine performance and drivability</li> <li>After operating the engine within the test parameters of DTC-628 check for any stored codes.</li> </ul> Does the engine operate normally with no stored codes?		System OK	Go to OBD System Check

## DTC 629- Fuel Pump Relay Coil Short to Power (SPN 1348:FMI 3)

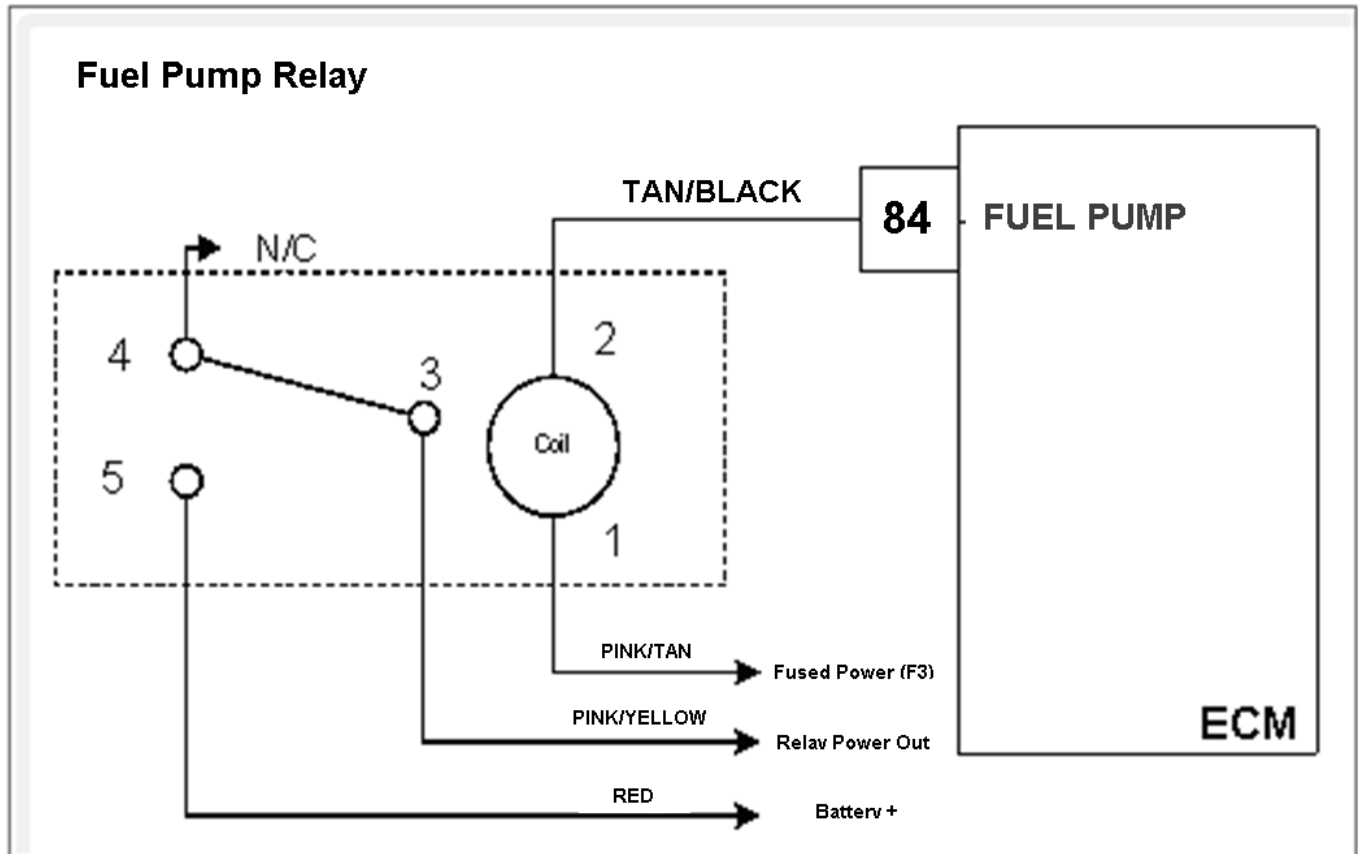

### Conditions for Setting the DTC

- Fuel pump relay check
- Check Condition-Key ON
- Fault Condition-Relay coil shorted to power

### Circuit Description

The fuel pump relay switches power out to the gasoline fuel pump. This fault will set if the ECM detects an open circuit on the relay control output

### Diagnostic Aid

Relay coil resistance changes with temperature. The following diagnostic charts have steps to measure relay coil resistance values. When checking the resistance values be sure the relay is at a reasonable temperature, between +20- and +100-degrees F.

Step	Action	Value(s)	Yes	No
1	Did you perform the On-Board (OBD) System Check?	-	Go to Step (2)	Go to OBD System Check Section
2	<ul style="list-style-type: none"> <li>DST connected and in the system data mode</li> <li>Key OFF</li> <li>Remove the power relay from the fuse block</li> <li>Using a DVOM check the resistance of the relay coil between terminals 1 and 2</li> </ul> Is the resistance value less than 60 ohms?		Go to Step (3)	Go to Step (4)
3	<ul style="list-style-type: none"> <li>Replace the power relay</li> </ul> Is the replacement complete?		Go to Step (9)	-
4	<ul style="list-style-type: none"> <li>Using a DVOM check for continuity between relay terminals 2 and 3</li> </ul> Do you have continuity between them?		Go to Step (3)	Go to Step (5)
5	<ul style="list-style-type: none"> <li>Key OFF</li> <li>Disconnect ECM wire harness connector C001</li> <li>Using a DVOM check for power between ECM pin 84 and engine ground with the key ON</li> </ul> Do you have power?	System battery voltage	Repair the short to power. See wiring harness repair.	Go to Step (6)
6	<ul style="list-style-type: none"> <li>Replace the power relay</li> </ul> Is the replacement complete?		Go to Step (7)	-
7	<ul style="list-style-type: none"> <li>Remove all test equipment except the DST.</li> <li>Connect any disconnected components, fuses, etc.</li> <li>Using the DST clear DTC information from the ECM.</li> <li>Turn the ignition OFF and wait 30 seconds.</li> <li>Start the engine and operate the vehicle to full operating temperature</li> <li>Observe the MIL</li> <li>Observe engine performance and drivability</li> <li>After operating the engine within the test parameters of DTC-629 check for any stored codes.</li> </ul> Does DTC 629 still re-set?		Go to Step (8)	Go to Step (9)

Step	Action	Value(s)	Yes	No
8	<ul style="list-style-type: none"> <li>Replace the ECM</li> </ul> Is the replacement complete?		Go to Step (9)	–
9	<ul style="list-style-type: none"> <li>Remove all test equipment except the DST.</li> <li>Connect any disconnected components, fuses, etc.</li> <li>Using the DST clear DTC information from the ECM.</li> <li>Turn the ignition OFF and wait 30 seconds.</li> <li>Start the engine and operate the vehicle to full operating temperature</li> <li>Observe the MIL</li> <li>Observe engine performance and drivability</li> <li>After operating the engine within the test parameters of DTC-629 check for any stored codes.</li> </ul> Does the engine operate normally with no stored codes?		System OK	Go to OBD System Check



## **DTC 642-External 5 Volt 1 Reference Low (SPN 1079:FMI 4)**

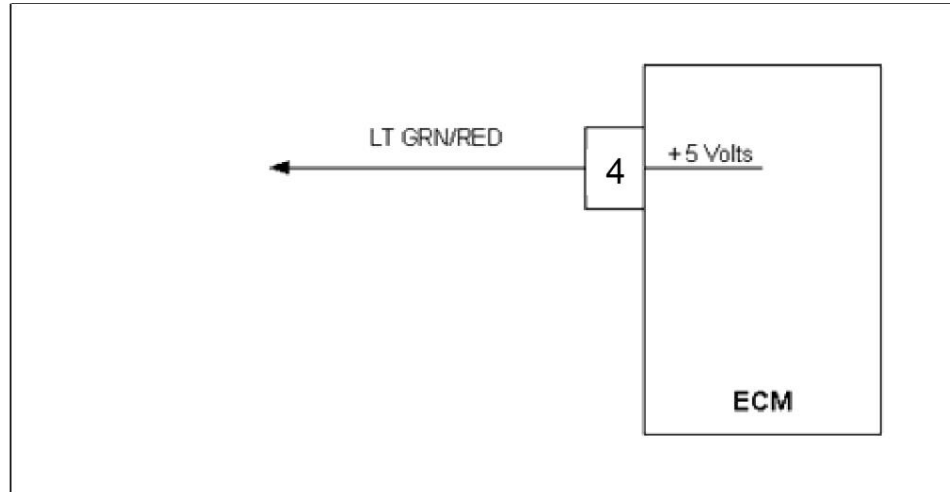

### **Conditions for Setting the DTC**

- External 5-volt reference
- Check Condition-Engine cranking or running
- Fault Condition-5-volt reference voltage lower than 4.60 volts
- MIL-ON during active fault
- Adaptive-Disabled during active fault

### **Circuit Description**

The External 5-volt supply powers many of the sensors and other components of the fuel system. The accuracy of the 5-volt supply is very important to the accuracy of the powered sensors and fuel control by the ECM. The ECM is able to determine if they are overloaded, shorted, or otherwise out of specification by monitoring the 5-volt supply.

This fault will set if the 5-volt reference is below 4.60 volts. Adaptive Learn will be disabled during this fault.

Step	Action	Value(s)	Yes	No
1	Did you perform the On-Board (OBD) SystemCheck?	-	Go to Step (2)	Go to OBD System Check Section
2	<ul style="list-style-type: none"> <li>Key ON, Engine Running</li> <li>DST (Diagnostic Scan Tool) connected inSystem Fault Mode</li> </ul> Does DST display DTC 642?		Go to Step (3)	Intermittent problem Go to Intermittent section
3	<ul style="list-style-type: none"> <li>Key OFF</li> <li>Disconnect ECM connector C001</li> <li>Using DVOM check for continuity betweenECM 5-volt reference pin 4 and engine ground</li> </ul> Do you have continuity?		Go to Step (5)	Go to Step (4)
4	<ul style="list-style-type: none"> <li>Replace ECM</li> </ul> Is the replacement complete?		Go to Step (7)	-
5	<ul style="list-style-type: none"> <li>While monitoring DVOM for continuity between ECM 5-volt reference and engine ground</li> <li>Disconnect each sensor (below) one at a time to find the shorted 5-volt reference. When continuity to ground is lost the last sensor disconnected is the area of suspicion.Inspect the 5-volt reference supply wire leadsfor shorts before replacing the sensor.</li> <li>TMAP</li> <li>Electronic Throttle</li> <li>FPP</li> <li>Crankshaft Sensor</li> <li>Camshaft Sensor</li> </ul> While disconnecting each sensor one at a time did you lose continuity?		Go to Step (6)	Repair shorted wire harness
6	<ul style="list-style-type: none"> <li>Replace the last disconnected sensorIs the replacement complete?</li> </ul>		Go to Step (7)	-
7	<ul style="list-style-type: none"> <li>Remove all test equipment except the DST.</li> <li>Connect any disconnected components, fuses, etc.</li> <li>Using the DST clear DTC information from the ECM.</li> <li>Turn the ignition OFF and wait 30 seconds.</li> <li>Start the engine and operate the vehicle to full operating temperature</li> <li>Observe the MIL</li> <li>Observe engine performance and drivability</li> <li>After operating the engine within the test parameters of DTC-642 check for any stored codes.</li> </ul> Does the engine operate normally with no stored codes?		System OK	Go to OBD System Check

## **DTC 643-External 5 Volt 1 Reference High (SPN 1079:FMI 3)**

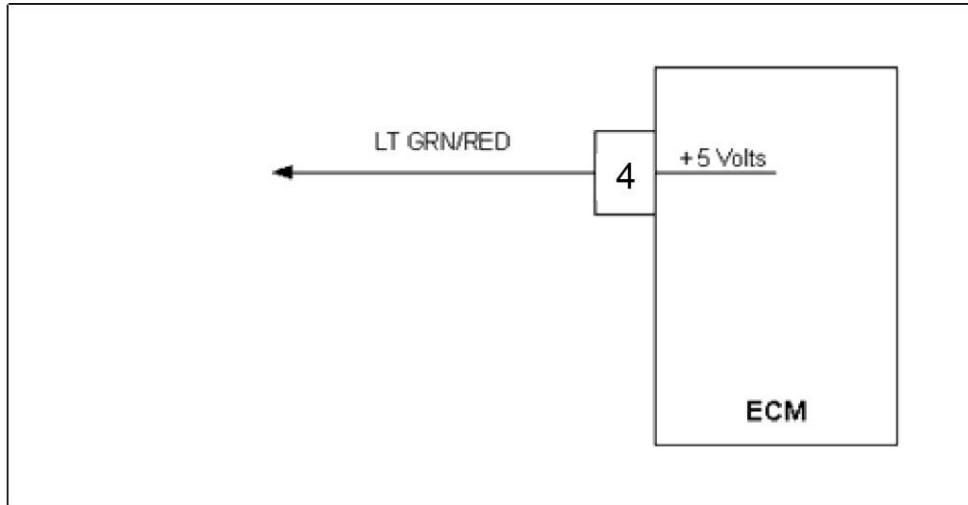

### **Conditions for Setting the DTC**

- External 5 volt reference
- Check Condition-Engine cranking or running
- Fault Condition-5 volt reference higher than 5.40 volts
- MIL-ON during active fault
- Adaptive-Disabled during active fault

### **Circuit Description**

The External 5 volt supply powers many of the sensors and other components in the fuel system. The accuracy of the 5-volt supply is very important to the accuracy of the powered sensors and fuel control by the ECM. The ECM is able to determine if they are overloaded, shorted, or other- wise out of specification by monitoring the 5volt supply. This fault will set if the 5-volt reference is greater than 5.40 volts anytime the engine is cranking or running. Adaptive Learn will be disabled during this fault.

Step	Action	Value(s)	Yes	No
1	Did you perform the On-Board (OBD) System Check?	-	Go to Step (2)	Go to OBD System Check Section
2	<ul style="list-style-type: none"> <li>Key ON, Engine running</li> <li>DST (Diagnostic Scan Tool) connected in System Data Mode</li> </ul> Does DST display DTC 643?		Go to Step (3)	Intermittent problem Go to Intermittent section
3	<ul style="list-style-type: none"> <li>Check all ECM ground connections</li> <li>Refer to Engine electrical power and ground distribution.</li> </ul> Are the ground connections, OK?		Go to Step (4)	Repair the circuit as necessary. Refer to Wiring Repairs in Engine Electrical.
4	<ul style="list-style-type: none"> <li>Key OFF</li> <li>Disconnect ECM connector C001</li> <li>Key ON</li> <li>Using DVOM check for Voltage between ECM harness wire pin 4 and engine ground</li> </ul> Do you have voltage?		Repair the circuit as necessary. Refer to Wiring Repairs in Engine Electrical.	Go to Step (5)
5	<ul style="list-style-type: none"> <li>Replace ECM</li> </ul> Is the replacement complete?		Go to Step (6)	-
6	<ul style="list-style-type: none"> <li>Remove all test equipment except the DST.</li> <li>Connect any disconnected components, fuses, etc.</li> <li>Using the DST clear DTC information from the ECM.</li> <li>Turn the ignition OFF and wait 30 seconds.</li> <li>Start the engine and operate the vehicle to full operating temperature</li> <li>Observe the MIL</li> <li>Observe engine performance and drivability</li> <li>After operating the engine within the test parameters of DTC-643 check for any stored codes.</li> </ul> Does the vehicle engine normally with no stored codes?		System OK	Go to OBD System Check

## DTC 650-MIL Control Open (SPN 1213:FMI 5)

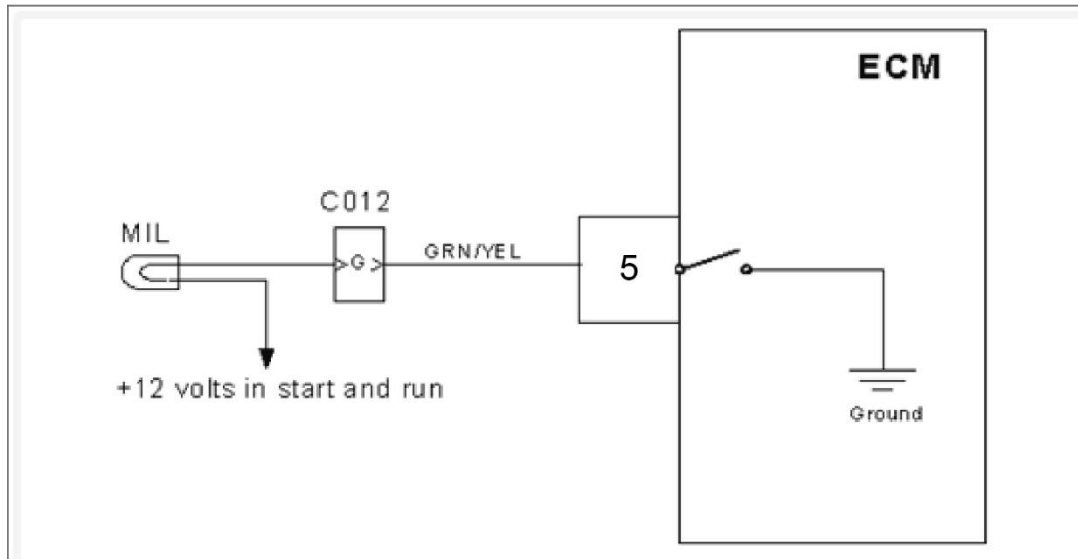

### Conditions for setting the DTC

- MIL check
- Check Condition-Key ON engine OFF
- Fault Condition-ECM MIL circuit open
- MIL Command-ON

### Circuit Description

The fuel system is equipped with OBD (On-Board Diagnostics). The system has a dash mounted MIL (Malfunction Indicator Lamp). The MIL serves as notification of an emissions related problem. The MIL also has the ability to flash DTC codes in what is referred to as the blink code mode. It will display DTCs that have been stored due to a possible system malfunction. The following DTC charts in this manual will instruct the technician to perform the OBD system check. This simply means to verify the operation of the MIL. The lamp should illuminate when the key is in the ON position, and the engine is not running. This feature verifies that the lamp is in proper working order. If the lamp does not illuminate with the vehicle key ON and engine OFF, repair it as soon as possible. Once the engine is in start or run mode, the lamp should go off. If the lamp stays on while the engine is in the start or run mode, a current diagnostic trouble code may be set or a problem may exist with the MIL electrical wiring. The electrical schematic above shows the MIL power source supplied to the lamp. The ECM completes the circuit to ground to turn the lamp ON. This fault will set if the ECM MIL control circuit is open.

Step	Action	Value(s)	Yes	No
1	Did you perform the On-Board (OBD) System Check?	-	Go to Step (2)	Go to OBD System Check Section
2	<ul style="list-style-type: none"> <li>• Key ON, Engine Running</li> <li>• DST (Diagnostic Scan Tool) connected inSystem Data Mode</li> <li>• Clear system fault code</li> <li>• Key OFF</li> <li>• Key ON</li> </ul> Does DTC 650 reset?		Go to Step (3)	Intermittent problem Go to Intermittent section
3	<ul style="list-style-type: none"> <li>• Remove the MIL bulb or driver circuit</li> <li>• Using a DVOM check for continuity throughthe bulb or driver device</li> </ul> Do you have continuity?		Go to Step (5)	Go to Step (4)
4	<ul style="list-style-type: none"> <li>• Replace the open bulb or driver devices the replacement complete?</li> </ul>		Go to Step (8)	-
5	<ul style="list-style-type: none"> <li>• Key OFF</li> <li>• Re-install the bulb or driver device</li> <li>• Disconnect vehicle interface connector C012</li> <li>• Using a DVOM check for continuity between vehicle interface connector pin G and battery positive</li> <li>• Key ON</li> </ul> Do you have continuity?		Go to Step (6)	Repair the open circuit as required. See wire harness repair
6	<ul style="list-style-type: none"> <li>• Disconnect ECM wire harness connector C001</li> <li>• Using a DVOM check for continuity between ECM harness connector pin 5 and vehicle interface connector pin G</li> </ul> Do you have continuity?		Go to Step (7)	Repair the open circuit as required. See wire harness repair
7	<ul style="list-style-type: none"> <li>• Inspect ECM wire harness connector pin 5 and vehicle interface connector pin G for damage, corrosion or contamination</li> </ul> Did you find a problem?		Correct the problem as required. See wiring harness repair	Go to Step (8)

Step	Action	Value(s)	Yes	No
8	<ul style="list-style-type: none"> <li>• Remove all test equipment except the DST.</li> <li>• Connect any disconnected components, fuses, etc.</li> <li>• Using the DST clear DTC information from the ECM.</li> <li>• Turn the ignition OFF and wait 30 seconds.</li> <li>• Start the engine and operate the vehicle to full operating temperature</li> <li>• Observe the MIL</li> <li>• Observe engine performance and drivability</li> <li>• After operating the engine within the test parameters of DTC-650 check for any stored codes.</li> </ul> <p>Does the engine operate normally with no stored codes?</p>		System OK	Go to OBD System check

## **DTC 652-External 5 Volt 2 Reference Low (SPN 1080:FMI 4)**

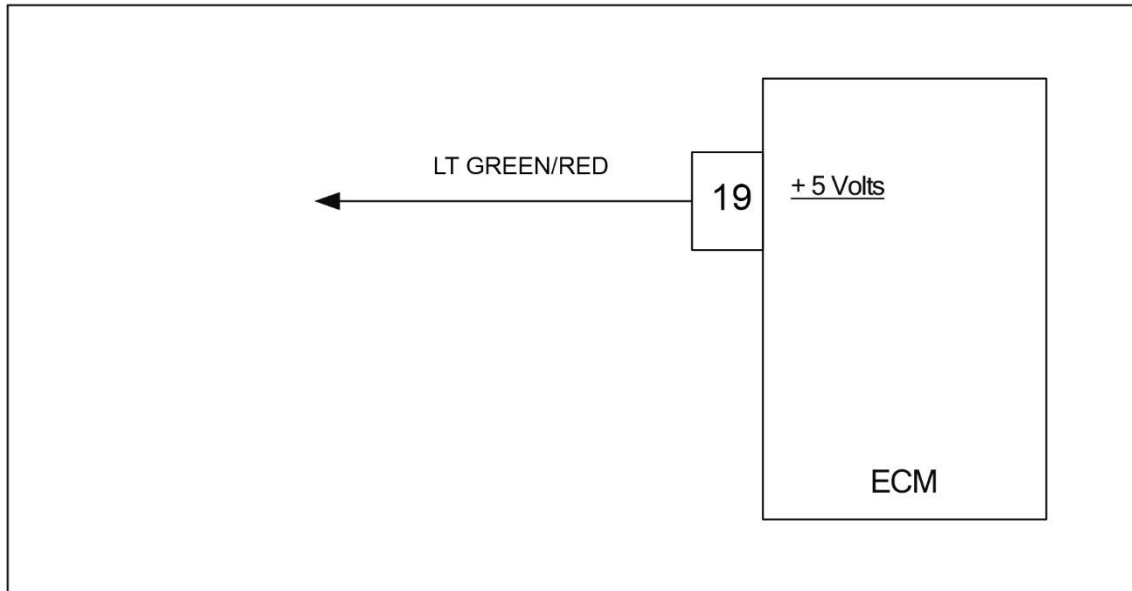

### **Conditions for Setting the DTC**

- External 5 volt reference
- Check Condition-Engine cranking or running
- Fault Condition-5 volt reference voltage lower than 3.00 volts
- MIL-On during active fault
- Adaptive-Disabled during active fault

### **Circuit Description**

The External 5-volt supply is normally dedicated to the FPP sensor 5-volt supply circuit. The accuracy of the 5-volt supply is very important to the accuracy of the FPP sensor circuit. The ECM is able to determine if the circuit is open, shorted, or otherwise out of specification by monitoring this 5-volt supply. This fault will set if the 5-volt reference is below 3.00 volts. Adaptive Learn will be disabled during this fault.



Step	Action	Value(s)	Yes	No
1	Did you perform the On-Board (OBD) System Check?	-	Go to Step (2)	Go to OBD System Check Section
2	<ul style="list-style-type: none"> <li>Key ON, Engine Running</li> <li>DST (Diagnostic Scan Tool) connected in System Fault Mode</li> </ul> Does DST display DTC 652?		Go to Step (3)	Intermittent problem Go to Intermittent section
3	<ul style="list-style-type: none"> <li>Key OFF</li> <li>Disconnect ECM connector C001</li> <li>Using DVOM check for continuity between ECM 5-volt reference pin 19 and engine ground</li> </ul> Do you have continuity?		Go to Step (5)	Go to Step (4)
4	<ul style="list-style-type: none"> <li>Replace ECM</li> </ul> Is the replacement complete?		Go to Step (7)	-
5	<ul style="list-style-type: none"> <li>While monitoring DVOM for continuity between ECM 5-volt reference and engine ground</li> <li>Disconnect each sensor (below) one at a time to find the shorted 5-volt reference. When continuity to ground is lost the last sensor disconnected is the area of suspicion. Inspect the 5-volt reference supply wire leads for shorts before replacing the sensor.</li> <li>FPP</li> </ul> While disconnecting each sensor one at a time did you lose continuity?		Go to Step (6)	Repair shorted wire harness
6	<ul style="list-style-type: none"> <li>Replace the last disconnected sensor</li> </ul> Is the replacement complete?		Go to step (7)	-
7	<ul style="list-style-type: none"> <li>Remove all test equipment except the DST.</li> <li>Connect any disconnected components, fuses, etc.</li> <li>Using the DST clear DTC information from the ECM.</li> <li>Turn the ignition OFF and wait 30 seconds.</li> <li>Start the engine and operate the vehicle to full operating temperature</li> <li>Observe the MIL</li> <li>Observe engine performance and drivability</li> <li>After operating the engine within the test parameters of DTC-652 check for any stored codes.</li> </ul> Does the engine operate normally with no stored codes?		System OK	Go to OBD System Check

## **DTC 653-External 5 Volt 2 Reference High (SPN 1080:FMI 3)**

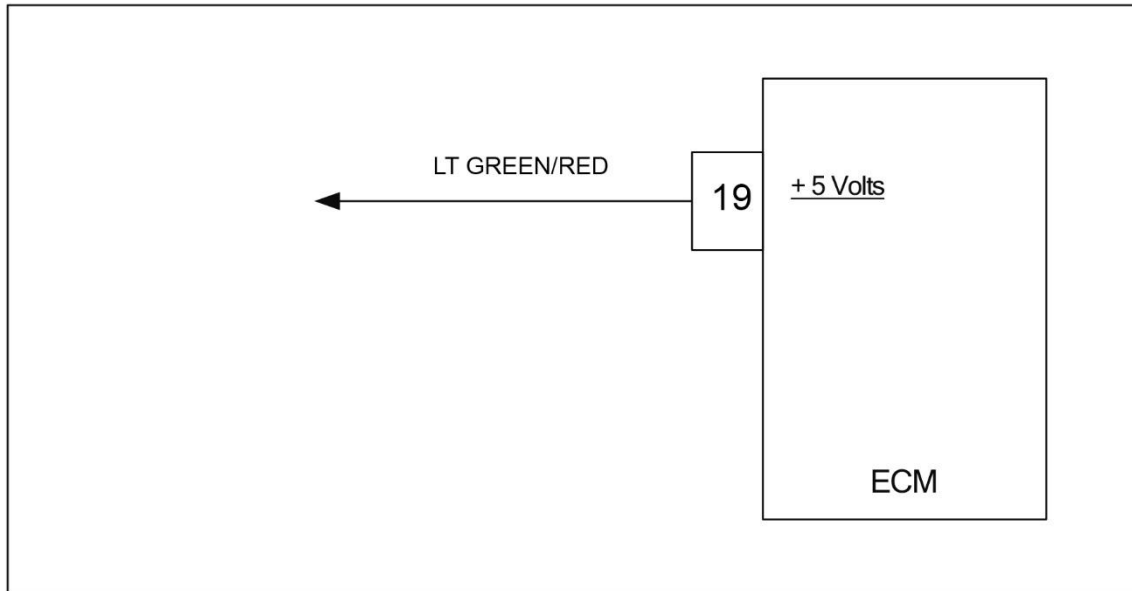

### **Conditions for Setting the DTC**

- External 5 volt reference
- Check Condition-Engine cranking or running
- Fault Condition-5 volt reference higher than 5.40 volts
- MIL-On during active fault
- Adaptive-Disabled during active fault

### **Circuit Description**

The External 5-volt supply is normally dedicated to the FPP sensor 5 volt supply circuit. The accuracy of the 5-volt supply is very important to the accuracy of the FPP sensor circuit. The ECM is able to determine if the circuit is open, shorted, or otherwise out of specification by monitoring this 5-volt supply. This fault will set if the 5-volt reference is above 5.40 volts. Adaptive Learn will be disabled during this fault.

Step	Action	Value(s)	Yes	No
1	Did you perform the On-Board (OBD) System Check?	-	Go to Step (2)	Go to OBD System Check Section
2	<ul style="list-style-type: none"> <li>Key ON, Engine running</li> <li>DST (Diagnostic Scan Tool) connected in System Data Mode</li> </ul> Does DST display DTC 653?		Go to Step (3)	Intermittent problem Go to Intermittent section
3	<ul style="list-style-type: none"> <li>Check all ECM ground connections. Refer to Engine electrical power and ground distribution.</li> </ul> Are the ground connections, Ok?		Go to Step (4)	Repair the circuit as necessary. Refer to Wiring Repairs in Engine Electrical.
4	<ul style="list-style-type: none"> <li>Key OFF</li> <li>Disconnect ECM connector C001</li> <li>Key ON</li> <li>Using DVOM check for Voltage between ECM harness wire pin 49 and engine ground</li> </ul> Do you have voltage?		Repair the circuit as necessary. Refer to Wiring Repairs in Engine Electrical.	Go to Step (5)
5	<ul style="list-style-type: none"> <li>Replace ECM</li> </ul> Is the replacement complete?		Go to Step (6)	-
6	<ul style="list-style-type: none"> <li>Remove all test equipment except the DST.</li> <li>Connect any disconnected components, fuses, etc.</li> <li>Using the DST clear DTC information from the ECM.</li> <li>Turn the ignition OFF and wait 30 seconds.</li> <li>Start the engine and operate the vehicle to full operating temperature</li> <li>Observe the MIL</li> <li>Observe engine performance and drivability</li> <li>After operating the engine within the test parameters of DTC-653 check for any stored codes.</li> </ul> Does the vehicle engine normally with no stored codes?		System OK	Go to OBD System Check

## DTC 685-Relay Coil Open (SPN 1485:FMI 5)

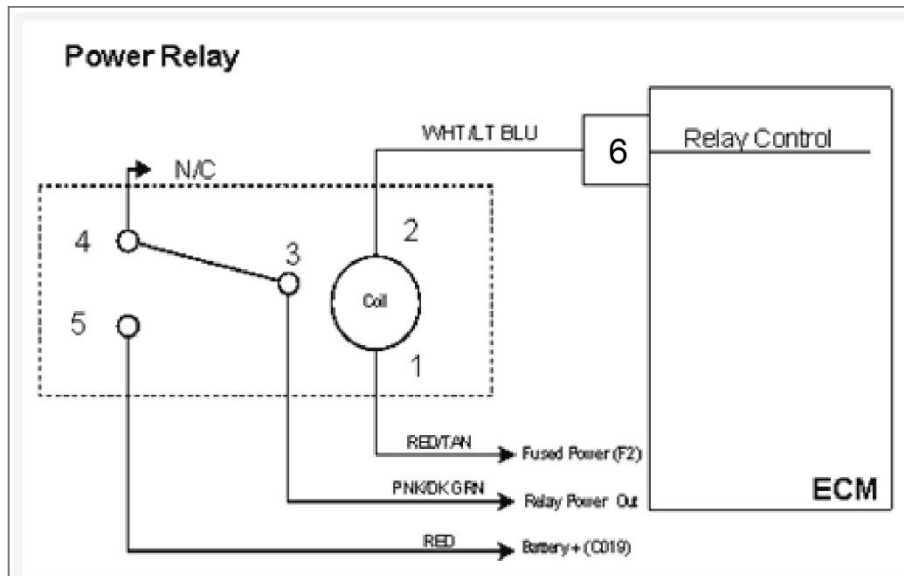

### Conditions for Setting the DTC

- Power relay check
- Check Condition-Key ON
- Fault Condition-Relay coil open

### Circuit Description

The power relay switches power out to various sensors, actuators, and solenoids in the fuel system. This fault will set if the ECM detects an open circuit on the relay control output.

### Diagnostic Aid

Relay coil resistance changes with temperature. The following diagnostic charts have steps to measure relay coil resistance values. When checking the resistance values be sure the relay is at a reasonable temperature, between +20- and +100-degrees F.

Step	Action	Value(s)	Yes	No
1	Did you perform the On-Board (OBD) System Check?	-	Go to Step (2)	Go to OBD System Check Section
2	<ul style="list-style-type: none"> <li>DST connected and in the system data mode</li> <li>Key OFF</li> <li>Remove the power relay from the fuse block</li> <li>Using a DVOM check the resistance of the relay coil between terminals 1 and 2</li> </ul> Is the resistance value less than 100 ohms?		Go to Step (4)	Go to Step (3)
3	<ul style="list-style-type: none"> <li>Replace the power relay</li> </ul> Is the replacement complete?		Go to Step (9)	-
4	<ul style="list-style-type: none"> <li>Check fuse F2</li> </ul> Is the fuse open?		Replace fuse F2	Go to Step (5)
5	<ul style="list-style-type: none"> <li>Disconnect ECM connector C001</li> <li>Using a DVOM check for continuity between ECM pin 6 and fuse block cavity for relay terminal 2</li> </ul> Do you have continuity?		Go to Step (6)	Repair the open circuit as required. See wiring harness repairs
6	<ul style="list-style-type: none"> <li>Remove fuse F2</li> <li>Using a DVOM check for continuity between fuse block cavity for relay terminal 1 and the power out of the F2 fuse holder</li> </ul> Do you have continuity?		Go to Step (7)	Repair the open circuit as required. See wiring harness repairs
7	<ul style="list-style-type: none"> <li>Check all system fuses.</li> <li>Check all relay placement positions in fuse block.</li> <li>Run complete pin to pin checks on chassis wiring to fuel system harness.</li> <li>See complete fuel system schematic for further details</li> </ul> Did you find the problem?		Go to Step (9)	Go to Step (8)

Step	Action	Value(s)	Yes	No
8	<ul style="list-style-type: none"> <li>• Replace the ECM</li> </ul> Is the replacement complete?		Go to Step (9)	–
9	<ul style="list-style-type: none"> <li>• Remove all test equipment except the DST.</li> <li>• Connect any disconnected components, fuses, etc.</li> <li>• Using the DST clear DTC information from the ECM.</li> <li>• Turn the ignition OFF and wait 30 seconds.</li> <li>• Start the engine and operate the vehicle to full operating temperature</li> <li>• Observe the MIL</li> <li>• Observe engine performance and drivability</li> <li>• After operating the engine within the test parameters of DTC-685 check for any stored codes.</li> </ul> Does the engine operate normally with no stored codes?		System OK	Go to OBD System Check

## DTC 686-Relay Control Ground Short (SPN 1485:FMI 4)

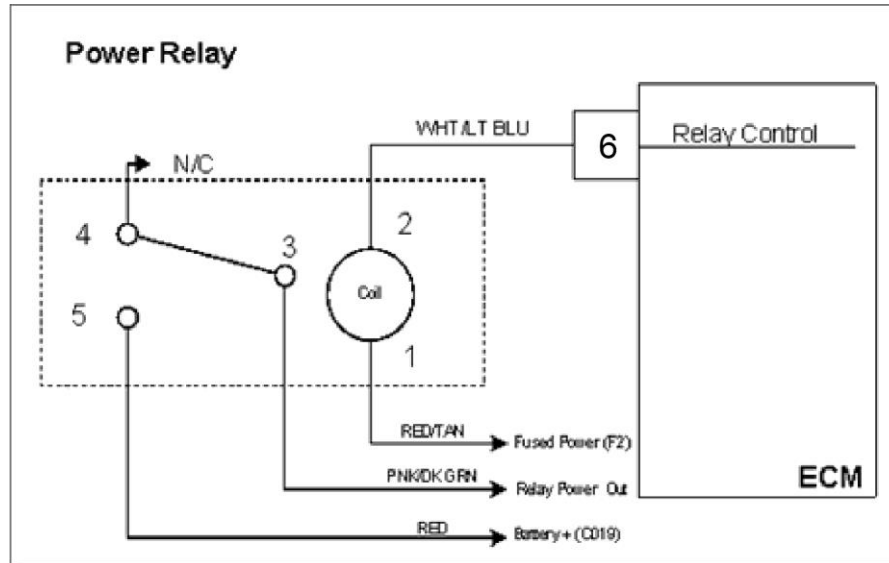

### Conditions for Setting the DTC

- Power relay ground control
- Check Condition-Key ON
- Fault Condition-Relay control shorted to ground

### Circuit Description

The power relay switches power out to various sensors, actuators, and solenoids in the fuel system. This fault will set if the ECM detects a short to ground on the relay control output.

### Diagnostic Aid

Relay coil resistance changes with temperature. The following diagnostic charts have steps to measure relay coil resistance values. When checking the resistance values be sure the relay is at a reasonable temperature, between +20- and +100-degrees F.

Step	Action	Value(s)	Yes	No
1	Did you perform the On-Board (OBD) System Check?	-	Go to Step (2)	Go to OBD System Check Section
2	<ul style="list-style-type: none"> <li>Key ON, DST connected in the System Data mode</li> <li>Clear DTC 686</li> <li>Start the engine</li> </ul> Does DTC 686 re-set?		Go to Step (4)	Intermittent problem Go to Intermittent section
3	<ul style="list-style-type: none"> <li>Disconnect ECM connector C001</li> <li>Using a DVOM check the resistance value between ECM pin 6 and engine ground</li> </ul> Is the resistance less than 60 ohms?		Go to Step (5)	Go to Step (7)
4	<ul style="list-style-type: none"> <li>Remove the power relay from the fuse block</li> <li>Using a DVOM check the resistance value again between ECM pin 71 and engine ground</li> </ul> Is the resistance less than 60 ohms?		Repair the shorted to ground relay control circuit as necessary. See wiring harness repairs	Go to Step (6)
5	<ul style="list-style-type: none"> <li>Replace the power relay</li> </ul> Is the replacement complete?		Go to Step (8)	-
6	<ul style="list-style-type: none"> <li>Replace ECM</li> </ul> Is the replacement complete?		Go to Step (8)	-
7	<ul style="list-style-type: none"> <li>Remove all test equipment except the DST.</li> <li>Connect any disconnected components, fuses, etc.</li> <li>Using the DST clear DTC information from the ECM.</li> <li>Turn the ignition OFF and wait 30 seconds.</li> <li>Start the engine and operate the vehicle to full operating temperature</li> <li>Observe the MIL</li> <li>Observe engine performance and drivability</li> <li>After operating the engine within the test parameters of DTC-686 check for any stored codes.</li> </ul> Does the engine operate normally with no stored codes?		System OK	Go to OBD System Check



## **DTC 687-Relay Coil Short to Power (SPN 1485:FMI 3)**

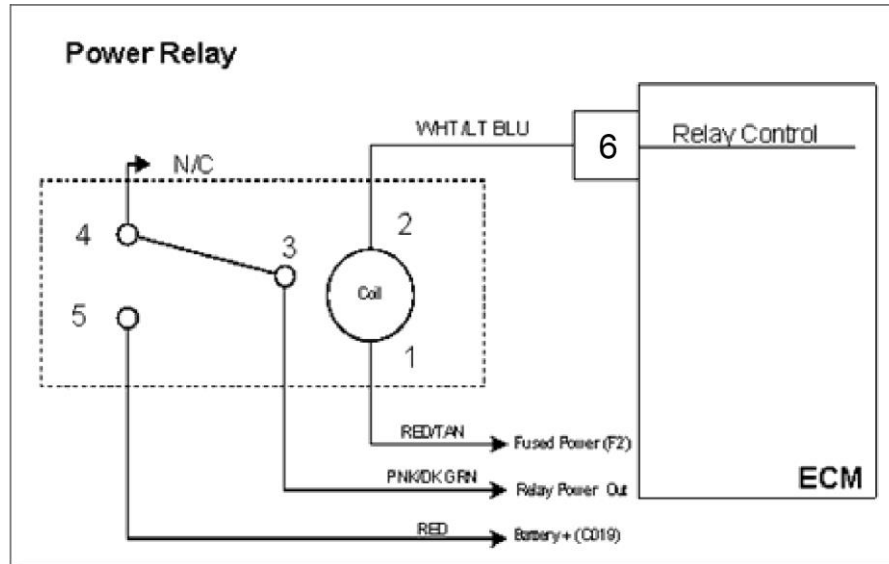

### **Conditions for Setting the DTC**

- Power relay check
- Check Condition-Key ON
- Fault Condition-Relay coil shorted to power

### **Circuit Description**

The power relay switches power out to various sensors, actuators, and solenoids in the fuel system. This fault will set if the ECM detects a short circuit to power on the relay control output.

### **Diagnostic Aid**

Relay coil resistance changes with temperature. The following diagnostic charts have steps to measure relay coil resistance values. When checking the resistance values be sure the relay is at a reasonable temperature, between +20 and +100 degrees F.

Step	Action	Value(s)	Yes	No
1	Did you perform the On-Board (OBD) System Check?	-	Go to Step (2)	Go to OBD System Check Section
2	<ul style="list-style-type: none"> <li>DST connected and in the system data mode</li> <li>Key OFF</li> <li>Remove the power relay from the fuse block</li> <li>Using a DVOM check the resistance of the relay coil between terminals 1 and 2</li> </ul> Is the resistance value less than 60 ohms?		Go to Step (3)	Go to Step (4)
3	<ul style="list-style-type: none"> <li>Replace the power relay Is the replacement complete?</li> </ul>		Go to Step (9)	-
4	<ul style="list-style-type: none"> <li>Using a DVOM check for continuity between relay terminals 2 and 3</li> </ul> Do you have continuity between them?		Go to Step (3)	Go to Step (5)
5	<ul style="list-style-type: none"> <li>Key OFF</li> <li>Disconnect ECM wire harness connector C001</li> <li>Using a DVOM check for power between ECM pin 6 and engine ground with the key ON</li> </ul> Do you have power?	System battery voltage	Repair the short to power. See wiring harness repair.	Go to Step (6)
6	<ul style="list-style-type: none"> <li>Replace the power relay Is the replacement complete?</li> </ul>		Go to Step (7)	-
7	<ul style="list-style-type: none"> <li>Remove all test equipment except the DST.</li> <li>Connect any disconnected components, fuses, etc.</li> <li>Using the DST clear DTC information from the ECM.</li> <li>Turn the ignition OFF and wait 30 seconds.</li> <li>Start the engine and operate the vehicle to full operating temperature</li> <li>Observe the MIL</li> <li>Observe engine performance and drivability</li> <li>After operating the engine within the test parameters of DTC-687 check for any stored codes.</li> </ul> Does DTC 687 still re-set?		Go to Step (8)	Go to Step (9)

Step	Action	Value(s)	Yes	No
8	<ul style="list-style-type: none"> <li>• Replace the ECM</li> </ul> Is the replacement complete?		Go to Step (9)	–
9	<ul style="list-style-type: none"> <li>• Remove all test equipment except the DST.</li> <li>• Connect any disconnected components, fuses, etc.</li> <li>• Using the DST clear DTC information from the ECM.</li> <li>• Turn the ignition OFF and wait 30 seconds.</li> <li>• Start the engine and operate the vehicle to full operating temperature</li> <li>• Observe the MIL</li> <li>• Observe engine performance and drivability</li> <li>• After operating the engine within the test parameters of DTC-687 check for any stored codes.</li> </ul> Does the engine operate normally with no stored codes?		System OK	Go to OBD System Check

## DTC 726 - Max Govern Speed Override

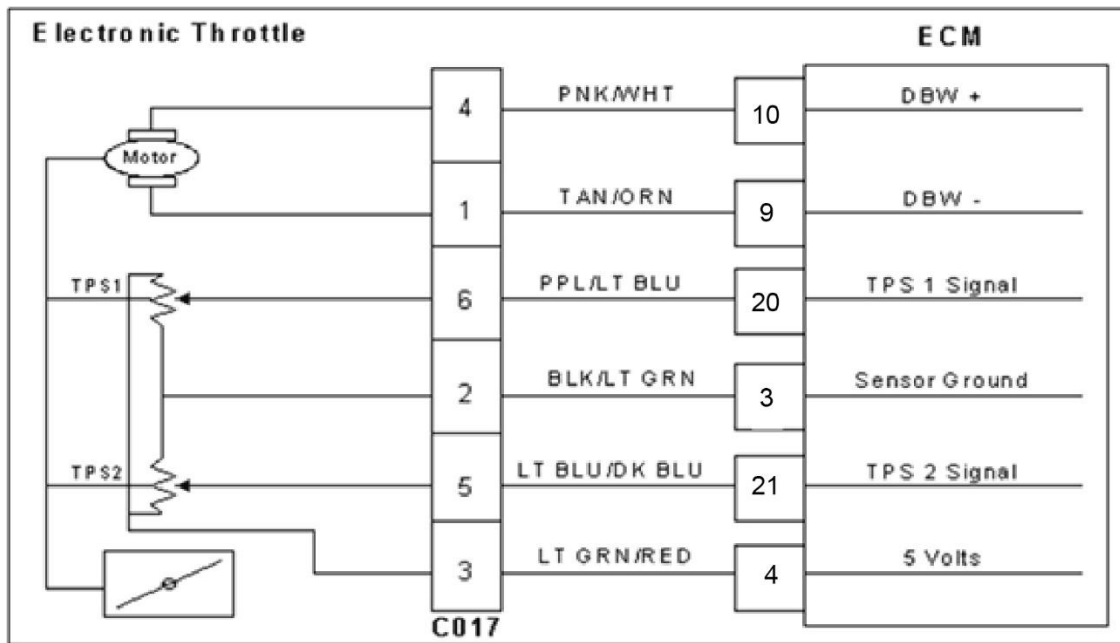

### Conditions for Setting the DTC

- Check Condition: Engine Running
- Fault Condition: Engine rpm greater than 2,250 rpm
- Fault condition active for 2 or more seconds
- MIL: ON during active fault

### Circuit description

This fault will set anytime the engine rpm exceeds 2,250 rpm for longer than 2 seconds. The MIL command is ON during this active fault.

### Diagnostic Aid

Check for other stored DTC codes before using the following DTC chart for this code set. Always diagnose and repair any existing codes starting with the lowest numerical code first.

## DTC 726 - Max Govern Speed Override

Step	Action	Value(s)	Yes	No
1	Did you perform the On-Board (OBD) System Check?	-	Go to Step (2)	Go to OBD System Check Section
2	Key ON, Engine OFF DST connected. Are any other DTC codes present with DTC 219?		Go to Step (3).	Go to Step (4)
3	Diagnose and repair any other DTC codes stored before proceeding with this chart. Have any other DTC codes been diagnosed and repaired?		Go to Step (4)	-
4	Check the service part number on the ECM to ensure the correct calibration is in use Is the Service Part Number Correct?		Go to Step (6)	Go to Step 5
5	Replace ECM with correct service part number Is the replacement complete?		Go to Step (9)	-
6	Check the mechanical operation of the throttle Is the mechanical operation of the throttle, OK?		Go to Step (8)	Go to Step (7)
7	Correct mechanical operation of the throttle. Refer to Engine & Component section. Has the mechanical operation of the throttle been corrected?		Go to Step (9)	-
8	Check engine for large manifold vacuum leaks. Refer to Symptom Diagnostic section. Did you find and correct the vacuum leak?		Go to Step (9)	Go to OBD System Check Section
9	Remove all test equipment except the DST. Connect any disconnected components, fuses, etc. Using the DST clear DTC information from the ECM. Turn the ignition OFF and wait 30 seconds. Start the engine and operate the vehicle to full operating temperature. Observe the MIL Observe engine performance and drivability After operating the engine within the test parameters of DTC-219 check for any stored codes. Does the engine operate normally with no stored codes?		System OK	Go to OBD System Check

## DTC 1111-Fuel Rev Limit (SPN 515:FMI 16)

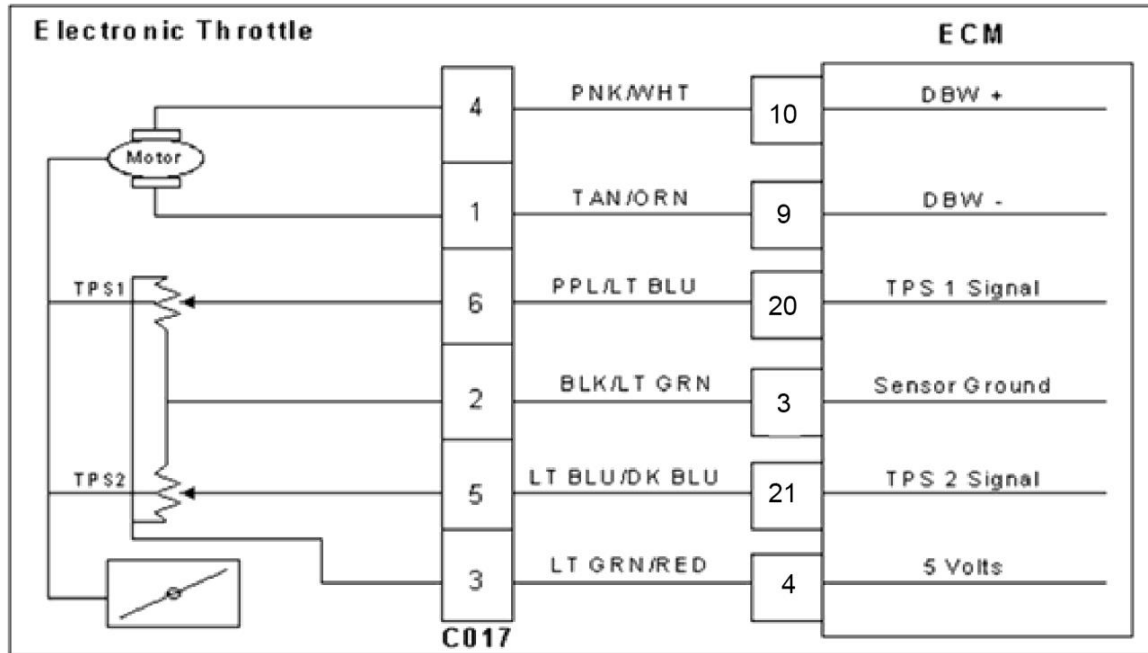

### Conditions for Setting the DTC

- Fuel Rev Limit
- Check Condition-Engine Running
- Fault Condition-Engine rpm greater than set limit
- MIL-ON during active fault

### Circuit Description

This fault will set anytime the engine rpm exceeds the specified speed settings in the calibration. This is generally set at 3000 rpms. The MIL command is ON during this active fault.

### Diagnostic Aid

Always check for other stored DTC codes before using the following DTC chart for this code set. Repair any existing codes starting with the lowest numerical code first.

Step	Action	Value(s)	Yes	No
1	Did you perform the On-Board (OBD) System Check?	-	Go to Step (2)	Go to OBD System Check Section
2	<ul style="list-style-type: none"> <li>Key ON, Engine OFF</li> <li>DST in Active Fault Mode</li> </ul> Are any other DTC codes present with DTC 1111?		Go to Step (3)	Go to Step (4)
3	<ul style="list-style-type: none"> <li>Diagnose and repair any other DTC codes before proceeding with this chart.</li> </ul> Have any other DTC codes been diagnosed and repaired?		Go to Step (4)	-
4	<ul style="list-style-type: none"> <li>Check the service part Number on the ECM to ensure correct calibration is in use</li> </ul> Is the service part Number Correct?		Go to Step (6)	Go to Step (5)
5	<ul style="list-style-type: none"> <li>Replace ECM with the correct service part number</li> </ul> Is the replacement complete?		Go to Step (9)	-
6	<ul style="list-style-type: none"> <li>Check the mechanical operation of the throttles</li> </ul> the mechanical operation of the throttle, OK?		Go to Step (8)	Go to Step (7)
7	<ul style="list-style-type: none"> <li>Correct mechanical operation of the throttle. Refer to Engine &amp; Component section</li> </ul> Has the mechanical operation of the throttle been corrected?		Go to Step (9)	-
8	<ul style="list-style-type: none"> <li>Check engine for large manifold vacuum leaks. Refer to Fuel Systems symptom diagnostics</li> </ul> Did you find and correct the vacuum leak?		Go to Step (9)	Go to OBD System Check Section
9	<ul style="list-style-type: none"> <li>Remove all test equipment except the DST.</li> <li>Connect any disconnected components, fuses, etc.</li> <li>Using the DST clear DTC information from the ECM.</li> <li>Turn the ignition OFF and wait 30 seconds.</li> <li>Start the engine and operate the vehicle to full operating temperature</li> <li>Observe the MIL</li> <li>Observe engine performance and drivability</li> <li>After operating the engine within the test parameters of DTC-1111 check for any stored codes.</li> </ul> Does the engine operate normally with no stored codes?		System OK	Go to OBD System Check

## DTC 1112-Spark Rev Limit (SPN 515: FMI 0)

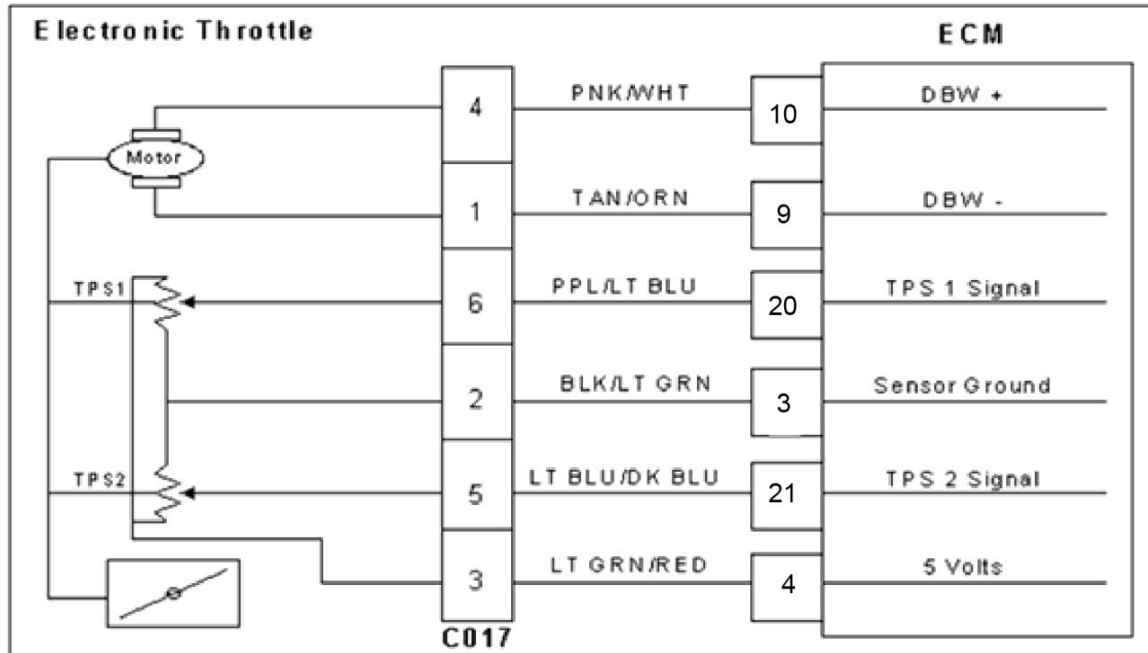

### Conditions for Setting the DTC

- Spark Rev Limit
- Check Condition-Engine running
- Fault Condition-Engine rpm greater than set limit
- MIL-ON during active fault
- Engine Shut Down

### Circuit description

This fault will set anytime the engine rpm exceeds the specified speed settings installed in the calibration. This is generally set at 3200 rpms. The MIL command is ON during this active fault and the engine will shut down.

### Diagnostic Aid

Always check for other stored DTC codes before using the following DTC chart for this code set. Repair any existing codes starting with the lowest numerical code first.



Step	Action	Value(s)	Yes	No
1	Did you perform the On-Board (OBD) System Check?	-	Go to Step (2)	Go to OBD System Check Section
2	<ul style="list-style-type: none"> <li>Key ON, Engine OFF</li> <li>DST connected</li> </ul> Are any other DTC codes present with DTC 1112?		Go to Step (3)	Go to Step (4)
3	<ul style="list-style-type: none"> <li>Diagnose any other DTC codes before proceeding with this chart.</li> </ul> Have any other DTC codes been diagnosed and repaired?		Go to Step (4)	-
4	<ul style="list-style-type: none"> <li>Check the service part number on the ECM to ensure correct calibration is in use</li> </ul> Is the service part number correct?		Go to Step (6)	Go to Step 5
5	<ul style="list-style-type: none"> <li>Replace ECM with correct service part number</li> </ul> Is the replacement complete?		Go to Step (9)	-
6	<ul style="list-style-type: none"> <li>Check the mechanical operation of the throttles</li> </ul> the mechanical operation of the throttle, OK?		Go to Step (8)	Go to Step (7)
7	<ul style="list-style-type: none"> <li>Correct mechanical operation of the throttle. Refer to Engine &amp; Component section</li> </ul> Has the mechanical operation of the throttle been corrected?		Go to Step (9)	-
8	<ul style="list-style-type: none"> <li>Check engine for large manifold vacuum leaks. Refer to Fuel Systems section Symptom Diagnostics</li> </ul> Did you find and correct the vacuum leak?		Go to Step (9)	Go to OBD System Check Section
9	<ul style="list-style-type: none"> <li>Remove all test equipment except the DST.</li> <li>Connect any disconnected components, fuses, etc.</li> <li>Using the DST clear DTC information from the ECM.</li> <li>Turn the ignition OFF and wait 30 seconds.</li> <li>Start the engine and operate the vehicle to full operating temperature</li> <li>Observe the MIL</li> <li>Observe engine performance and drivability</li> <li>After operating the engine within the test parameters of DTC-1112 check for any stored codes.</li> </ul> Does the engine operate normally with no stored codes?		System OK	Go to OBD System Check

## **DTC 1121 FPP 1 And 2 Redundancy Lost (SPN 91: FMI 31)**

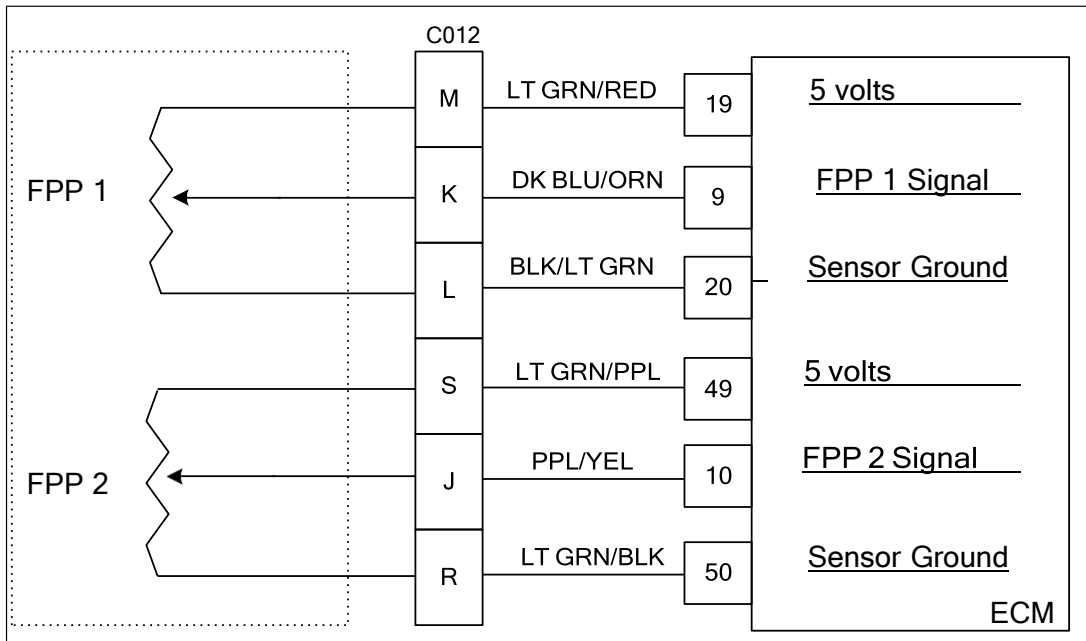

### **Conditions for Setting the DTC**

- Foot pedal position sensor 1 and 2
- Check Condition-Key ON
- Fault Condition-FPP1 and FPP 2 redundancy lost
- MIL-ON
- Force idle
- Low rev limit

### **Circuit Description**

The foot pedal position sensor uses variable resistors to determine signal voltage based on foot pedal position. Although the voltage outputs are different, the calculated throttle position values should be very close to the same. This fault will set if FPP 1 or FPP 2 positions are 20% greater or 20% less than the expected throttle position target. The MIL command is ON. Forced idle and low rev limit are in effect during this fault limiting full power output.

### **Diagnostic Aid**

It is very likely that in the event this code sets, other codes will set along with it. Always diagnose and repair codes starting with the lowest numerical value first. It is possible that by correcting the lower code sets first the problem will be corrected. FPP sensors are OEM specific and vary in configuration. The exact wire color and pin numbers for the FPP must be verified in the OEM chassis wiring schematic. The FPP sensor used in this system provides two sensors in one packaged assembly. FPP1 and FPP 2 are not serviceable individually, and in the event of a failure the complete FPP assembly must be replaced.

Step	Action	Value(s)	Yes	No
1	Did you perform the On-Board (OBD) System Check?		Go to Step (2)	Go to OBD System Check
2	<ul style="list-style-type: none"> <li>Diagnose any other lower numerical value codes that may be present first</li> </ul> Did this resolve the problem?		Go to Step (7)	Go to Step (3)
3	<ul style="list-style-type: none"> <li>Follow the diagnostic chart for DTC 2126</li> </ul> Did the chart resolve the problem?		Go to Step (7)	Go to Step (4)
4	<ul style="list-style-type: none"> <li>Follow the diagnostic chart for DTC 2121</li> </ul> Did the chart resolve the problem?		Go to Step (7)	Go to Step (5)
5	<ul style="list-style-type: none"> <li>Inspect FPP and C012 connector pins for damage corrosion or contamination</li> </ul> Did you find the problem?		Correct the problem as required. See wiring harness repair.	Go to Step (6)
6	<ul style="list-style-type: none"> <li>Key OFF</li> <li>Disconnect ECM connector C001</li> <li>Inspect pins 9, 10, 19, 20, 49 and 50 for damage corrosion or contamination.</li> </ul> Did you find a problem?		Correct the problem as required. See wiring harness repair.	–
7	<ul style="list-style-type: none"> <li>Remove all test equipment except the DST.</li> <li>Connect any disconnected components, fuses, etc.</li> <li>Using the DST clear DTC information from the ECM.</li> <li>Turn the ignition OFF and wait 30 seconds.</li> <li>Start the engine and operate the vehicle to full operating temperature</li> <li>Observe the MIL</li> <li>Observe engine performance and drivability</li> <li>After operating the engine within the test parameters of DTC-1121 check for any stored codes.</li> </ul> Does the engine operate normally with no stored codes?		System OK	Go to OBD System Check

## **DTC 1151-Closed Loop Multiplier High LPG (SPN 4236:FMI 0)**

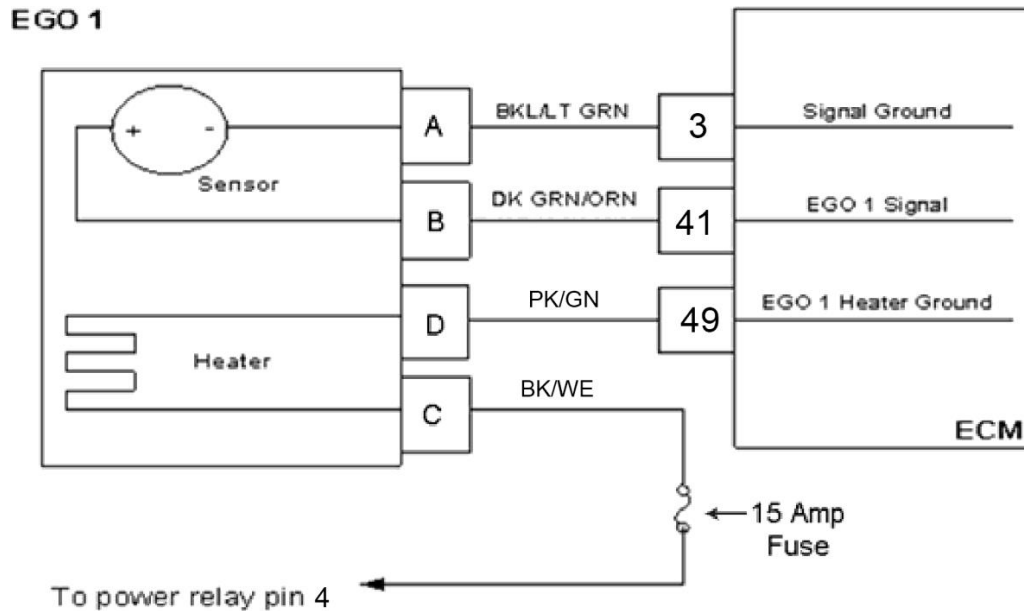

### **Conditions for Setting the DTC**

- Heated Oxygen Sensor
- Check Condition-Engine running
- Fault Condition-Closed Loop multiplier out of range (greater than 35%)
- MIL-ON

### **Circuit description**

The EGO sensor is used to determine if the fuel flow to the engine is correct by measuring the oxygen content in the exhaust gas. The ECM uses this information to correct the fuel flow with the Closed Loop multiplier and the adaptive multiplier. This fault sets if the Closed Loop multiplier exceeds the limits of normal operation and cannot correctly modify the fuel flow within its limits.

### **Diagnostic Aid**

**Oxygen Sensor Wire** Heated Oxygen sensor wires may be mis-routed and contacting the exhaust manifold.

**Vacuum Leaks** Large vacuum leaks and crankcase leaks can cause a lean exhaust condition, especially at light load.

**Fuel Mixer** System can be lean due to faulty EPR (Electronic Pressure Regulator) or faulty fuel mixer.

**Fuel Pressure** Low fuel pressure, faulty fuel regulator or contaminated fuel filter can cause fuel the system torun lean

**Exhaust Leaks** If there is an exhaust leak, outside air can be pulled into the exhaust and past the O2 sensor causing a false lean condition.

**Fuel Quality** Contaminated or spoiled fuel can cause the fuel system to be lean.

**Ground Problem** ECM grounds must be clean, tight and in the proper location

Step	Action	Value(s)	Yes	No
1	<ul style="list-style-type: none"> <li>Perform the On-Board (OBD) System Check? Are any other DTCs present?</li> </ul>		Go to Step (3)	Go to Step (2)
2	Visually and physically check the following items: <ul style="list-style-type: none"> <li>The air intake duct for being collapsed or restricted</li> <li>The air filter for being plugged</li> <li>System power fuses are good and in the proper location</li> <li>The EGO 1 sensor installed securely, and the wire leads not contacting the exhaust manifold or ignition wires</li> <li>ECM grounds must be clean and tight. Refer to Engine Electrical Power and Ground Distribution</li> <li>Fuel System Diagnostics. Refer to Fuel System Diagnostics</li> </ul> Was a repair made?		Go to Step (9)	Go to Step (4)
3	<ul style="list-style-type: none"> <li>Diagnose any other DTC codes before proceeding with this chart. Always repair existing codes starting with the lowest numerical code set first. Have any other DTC codes been detected, diagnosed and repaired?</li> </ul>		Go to Step (9)	Go to step (4)
4	<ul style="list-style-type: none"> <li>Disconnect EGO1 connector C005</li> <li>Using a DVOM check for voltage between EGO 1 connector pin D and engine ground</li> <li>Key ON</li> </ul> <b>(CHECK MUST BE MADE WITHIN 30 SECONDS OR BEFORE POWER RELAYS SHUTS DOWN)</b> Do you have voltage?	System voltage	Go to Step (5)	Repair the open EGO power circuit as necessary. Refer to Wiring Repairs in Engine Electrical.
5	<ul style="list-style-type: none"> <li>Key OFF</li> <li>Disconnect EGO 1 sensor wire harness connector C005</li> <li>Disconnect ECM wire harness connector C001</li> <li>Key ON</li> <li>Using a high impedance DVOM check for continuity between EGO 1 connector signal pin A and engine ground</li> </ul> Do you have continuity?		Repair the shorted circuit as necessary. Refer to Wiring Repairs in Engine Electrical.	Go to Step (6)

Step	Action	Value(s)	Yes	No
6	<ul style="list-style-type: none"> <li>Using a high impedance DVOM check for continuity between EGO 1 connector signal ground pin A and EGO 1 signal pin B.</li> </ul> Do you have continuity?		Repair the shorted circuit as necessary. Refer to Wiring Repairs in Engine Electrical.	Go to Step (7)
7	<ul style="list-style-type: none"> <li>Using a high impedance DVOM check for continuity between EGO 1 heater ground pinD and ECM pin 49</li> </ul> Do you have continuity?		Go to step (8)	Repair the open EGO heater ground
8	<ul style="list-style-type: none"> <li>Replace EGO 1 sensor</li> </ul> Is the replacement complete?		Go to Step (9)	-
9	<ul style="list-style-type: none"> <li>Remove all test equipment except the DST.</li> <li>Connect any disconnected components, fuses, etc.</li> <li>Using the DST clear DTC information from the ECM.</li> <li>Turn the ignition OFF and wait 30 seconds.</li> <li>Start the engine and operate the vehicle to full operating temperature</li> <li>Observe the MIL</li> <li>Observe engine performance and drivability</li> <li>After operating the engine within the test parameters of DTC-1151 check for any stored codes.</li> </ul> Does the engine operate normally with no stored codes?		System OK	Go to OBD System Check

## DTC 1152-Closed Loop Multiplier Low LPG (SPN 4236:FMI 1)

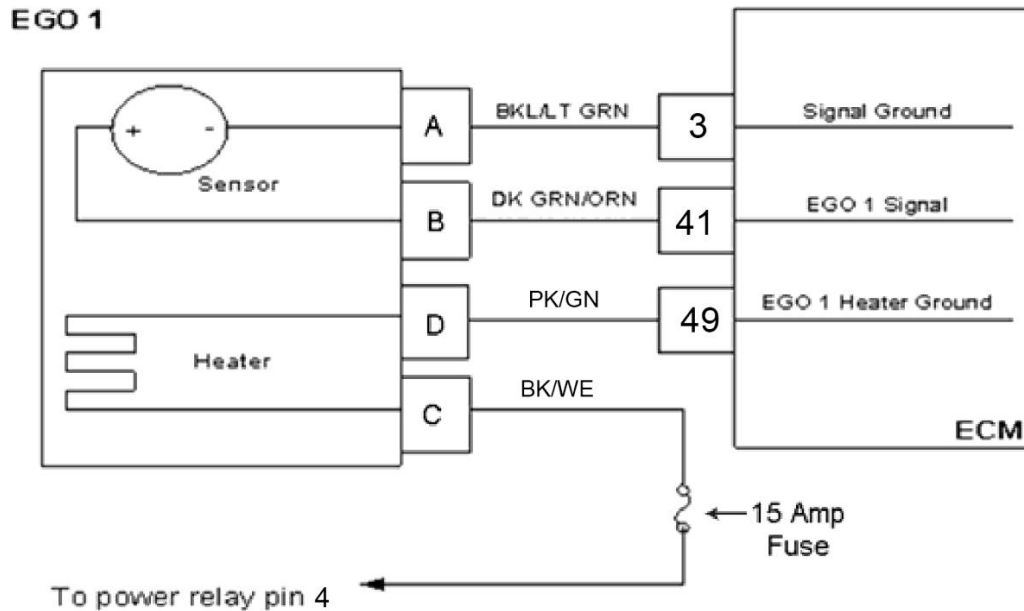

### Conditions for Setting the DTC

- Heated Oxygen Sensor
- Functional Fault-Closed Loop multiplier out of range (at limit of -35%)
- MIL Disabled

### Circuit Description

The EGO 1 sensor is used to determine if the fuel flow to the engine is correct by measuring the oxygen content in the exhaust gas. The ECM uses this information to correct the fuel flow with the Closed Loop multiplier and the adaptive multiplier. This fault sets if the Closed Loop multiplier exceeds the limits of normal operation. When the multiplier cannot correctly modify the fuel flow within its limits, it is limited at -35%.

### Diagnostic Aid

**Fuel System** High secondary fuel pressure will cause the system to run rich. A worn fuel mixer, faulty EPR (Electronic Pressure Regulator) may also cause the system to run rich.

**Fuel Quality** A drastic variation in fuel quality (very high butane content) may cause the fuel system to run rich. Be sure that the specified HD-5 or HD-10 motor fuel grade LPG is used.

**Air Filter** A plugged, damaged or modified air filter may cause the system to run rich.

Step	Action	Value(s)	Yes	No
1	<ul style="list-style-type: none"> <li>Perform the On-Board (OBD) System Check? Are any other DTCs present?</li> </ul>		Go to Step (3)	Go to Step (2)
2	Visually and physically check the following items: <ul style="list-style-type: none"> <li>The air intake duct for being collapsed or restricted</li> <li>The air filter for being plugged</li> <li>The EGO sensor installed securely, and the wire leads not damaged contacting the secondary ignition wires</li> <li>ECM grounds for being clean and tight.</li> <li>Run the fuel system diagnostic checks</li> </ul> Was a repair made?		Go to Step (6)	Go to Step (4)
3	<ul style="list-style-type: none"> <li>Diagnose any other DTC codes before proceeding with this chart.</li> </ul> Have any other DTC codes been detected, diagnosed and repaired?		Go to Step (6)	Go to Step (4)
4	<ul style="list-style-type: none"> <li>Key OFF</li> <li>Disconnect EGO sensor wire harness connector</li> <li>Disconnect ECM wire harness connector</li> <li>Key ON</li> <li>Using a DVOM check for voltage at the EGO1 connector C005 signal pin C and engine ground</li> </ul> Do you have voltage?		Repair the circuit short to voltage as necessary. Refer to wiring harness repair.	Go to Step (5)
5	<ul style="list-style-type: none"> <li>Replace EGO sensor</li> </ul> Is the replacement complete?		Go to Step (6)	-
6	<ul style="list-style-type: none"> <li>Remove all test equipment except the DST.</li> <li>Connect any disconnected components, fuses, etc.</li> <li>Using the DST clear DTC information from the ECM.</li> <li>Turn the ignition OFF and wait 30 seconds.</li> <li>Start the engine and operate the vehicle to full operating temperature</li> <li>Observe the MIL</li> <li>Observe engine performance and drivability</li> <li>After operating the engine within the test parameters of DTC-1152 check for any stored codes.</li> </ul> Does the engine operate normally with no stored codes?		System OK	Go to OBD System Check



## DTC 1153 - Closed Loop Multiplier High NG

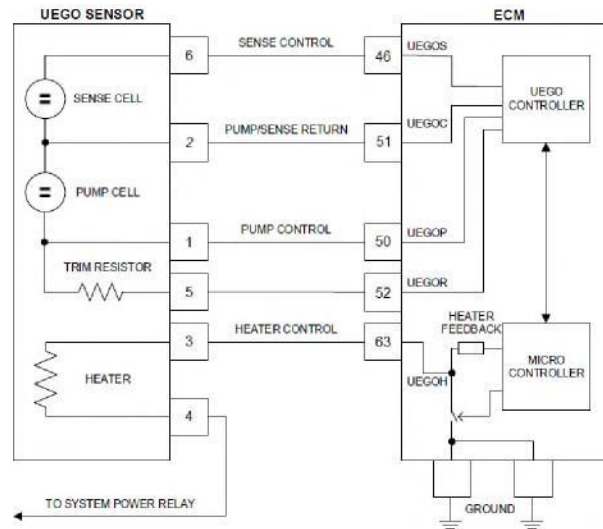

### Conditions for Setting the DTC

- Functional Fault: Closed Loop multiplier out of range (greater than 35%) while running on natural gas
- MIL: Disabled

### Circuit Description

The UEGO sensor is used to determine if the fuel flow to the engine is correct by measuring the oxygen content in the exhaust gas. The ECM uses this information to correct the fuel flow with the Closed Loop multiplier and the adaptive multiplier. This fault sets if the Closed Loop multiplier exceeds the limits of normal operation and cannot correctly modify the fuel flow within its limits.

### Diagnostic Aid

**Vacuum Leaks** Large vacuum leaks and crankcase leaks can cause a lean exhaust condition, especially at light load.

**Fuel Mixer** System can be lean due to a faulty EPR (Electronic Pressure Regulator) or faulty fuel mixer.

**Fuel Pressure** System will be lean if fuel pressure is too low. Ensure fuel pressure is not too low, and that gaseous fuel control actuator/regulator has proper fuel pressure under all operating conditions.

**Exhaust Leaks** If there is an exhaust leak, outside air can be pulled into the exhaust and past the O<sub>2</sub>-sensor causing a false lean condition.

**Misfire** A misfiring cylinder will pass oxygen through rather than burning it. The sensor will interpret this oxygen as a lean condition and enrichen the fuel mixture.

**Fuel Quality** A drastic variation in fuel quality may cause the system to be lean.

**Ground Problem** ECM and engine must be grounded to the battery with very little resistance allowing for proper current flow. Faulty grounds can cause current supply issues resulting in many undesired problems. **Oxygen Sensor Wire** Sensor may be mispositioned contacting the exhaust. Check for short to ground between harness and sensor sense signal.

**If all tests are OK, replace the O<sub>2</sub> sensors with known good parts and retest.**

#### Note:

- If one bank shows high adaptive and the other is low, the O<sub>2</sub> sensor leads are crossed. Trace those wires back to their ECM's are correct accordingly.

## DTC 1154 - Closed Loop Multiplier Low NG

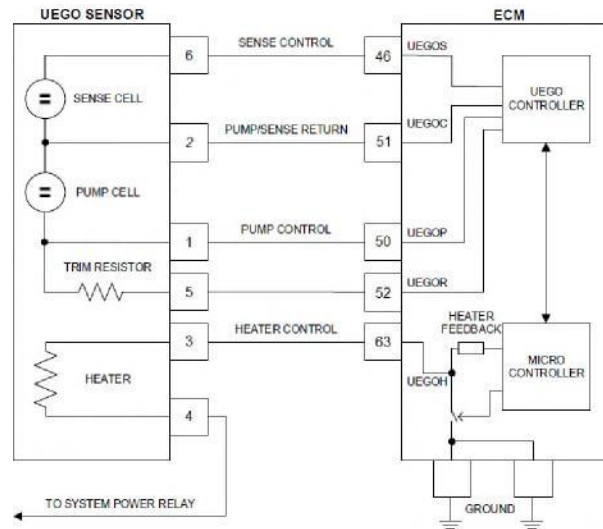

### Conditions for Setting the DTC

- Functional Fault: Closed Loop multiplier out of range (at limit of -35%) while running on natural gas
- MIL: Disabled

### Circuit Description

The UEGO sensor is used to determine if the fuel flow to the engine is correct by measuring the oxygen content in the exhaust gas. The ECM uses this information to correct the fuel flow with the Closed Loop multiplier and the adaptive multiplier. This fault sets if the Closed Loop multiplier exceeds the limits of normal operation. When the multiplier cannot correctly modify the fuel flow within its limits, it is limited at -35%.

### Diagnostic Aid

**Fuel System** High secondary fuel pressure will cause the system to run rich. A worn fuel mixer, faulty EPR (Electronic Pressure Regulator) may also cause the system to run rich.

**Fuel Quality** A drastic variation in fuel quality (high content of ethane and heavier hydrocarbons) may cause the fuel system to run rich. If running on wellhead gas, obtain a current gas analysis report for your fuel source. Wells can change over time and the gas supply may be different than when a sample was originally taken.

**Air Filter** A plugged, damaged or modified air filter may cause the system to run rich.

#### Note:

- If one bank shows high adaptive and the other is low, the O<sub>2</sub> sensor leads are crossed. Trace those wires back to their ECM's are correct accordingly.

## DTC 1155-Closed Loop Multiplier High Gasoline (SPN 4236:FMI 0)

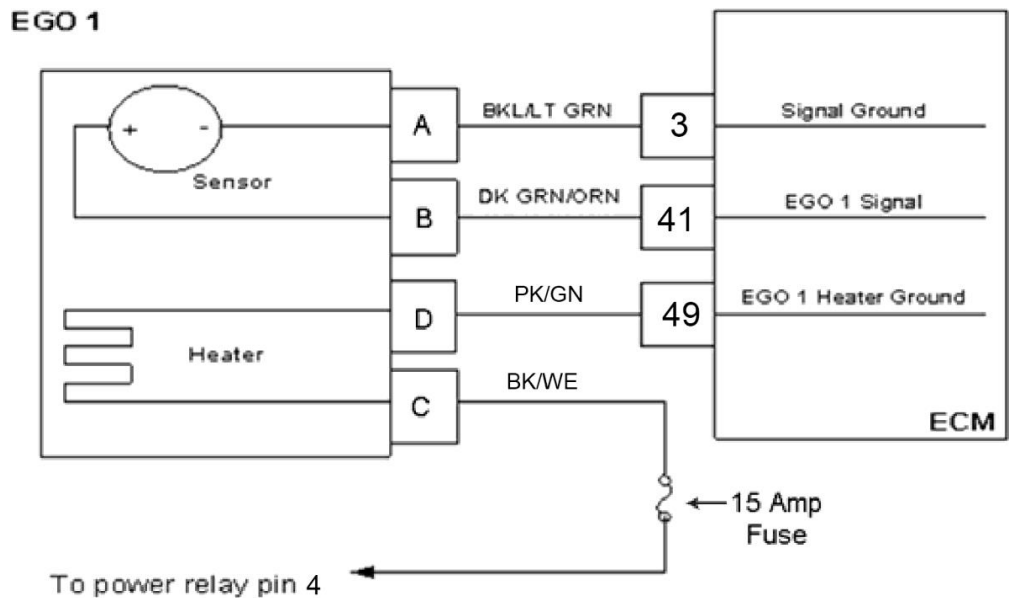

### Conditions for Setting the DTC

- Heated Oxygen Sensor
- Check Condition-Engine running
- Fault Condition-Closed Loop multiplier out of range (greater than 35%)
- MIL-ON

### Circuit description

The EGO sensor is used to determine if the fuel flow to the engine is correct by measuring the oxygen content in the exhaust gas. The ECM uses this information to correct the fuel flow with the Closed Loop multiplier and the adaptive multiplier. This fault sets if the Closed Loop multiplier exceeds the limits of normal operation and cannot correctly modify the fuel flow within its limits.

### Diagnostic Aid

**Oxygen Sensor Wire** Heated Oxygen sensor wires may be mis-routed and contacting the exhaust manifold.

**Vacuum Leaks** Large vacuum leaks and crankcase leaks can cause a lean exhaust condition at especially at light load.

**Fuel Mixer** System can be lean due to faulty EPR (Electronic Pressure Regulator) or faulty fuelmixer.

**Fuel Pressure** Low fuel pressure, faulty fuel regulator or contaminated fuel filter can cause fuel the system to run lean

**Exhaust Leaks** If there is an exhaust leak, outside air can be pulled into the exhaust and past the O2-sensor causing a false lean condition.

**Fuel Quality** Contaminated or spoiled fuel can cause the fuel system to be lean.

**Ground Problem** ECM grounds must be clean, tight and in the proper location.

Step	Action	Value(s)	Yes	No
1	<ul style="list-style-type: none"> <li>Perform the On-Board (OBD) System Check? Are any other DTCs present?</li> </ul>		Go to Step (3)	Go to Step (2)
2	<p>Visually and physically check the following items:</p> <ul style="list-style-type: none"> <li>The air intake duct for being collapsed or restricted</li> <li>The air filter for being plugged</li> <li>System power fuses are good and in the proper location</li> <li>The EGO 1 sensor installed securely, and the wire leads not contacting the exhaust manifold or ignition wires</li> <li>ECM grounds must be clean and tight. Refer to Engine Electrical Power and Ground Distribution</li> <li>Fuel System Diagnostics. Refer to Fuel System Diagnostics</li> </ul> <p>Was a repair made?</p>		Go to Step (9)	Go to Step (4)
3	<ul style="list-style-type: none"> <li>Diagnose any other DTC codes before proceeding with this chart. Always repair existing codes starting with the lowest numerical code set first.</li> </ul> <p>Have any other DTC codes been detected, diagnosed, and repaired?</p>		Go to Step (9)	Go to step (4)
4	<ul style="list-style-type: none"> <li>Disconnect EGO1 connector C005</li> <li>Using a DVOM check for voltage between EGO 1 connector pin B and engine ground</li> <li>Key ON</li> </ul> <p><b>(CHECK MUST BE MADE WITHIN 30 SECONDS OR BEFORE POWER RELAYS SHUTS DOWN)</b></p> <p>Do you have voltage?</p>	System voltage	Go to Step (5)	Repair the open EGO power circuit as necessary. Refer to Wiring Repairs in Engine Electrical.
5	<ul style="list-style-type: none"> <li>Key OFF</li> <li>Disconnect EGO 1 sensor wire harness connector C005</li> <li>Disconnect ECM wire harness connector C001</li> <li>Key ON</li> <li>Using a high impedance DVOM check for continuity between EGO 1 connector signal pin A and engine ground</li> </ul> <p>Do you have continuity?</p>		Repair the shorted circuit as necessary. Refer to Wiring Repairs in Engine Electrical.	Go to Step (6)

Step	Action	Value(s)	Yes	No
6	<ul style="list-style-type: none"> <li>Using a high impedance DVOM check for continuity between EGO 1 connector signal ground pin C and EGO 1 signal pin A</li> </ul> Do you have continuity?		Repair the shorted circuit as necessary. Refer to Wiring Repairs in Engine Electrical.	Go to Step (7)
7	<ul style="list-style-type: none"> <li>Using a high impedance DVOM check for continuity between EGO 1 heater ground pinD and ECM pin 49</li> </ul> Do you have continuity?		Go to step (8)	Repair the open EGO heater ground
8	<ul style="list-style-type: none"> <li>Replace EGO 1 sensor</li> </ul> Is the replacement complete?		Go to Step (9)	-
9	<ul style="list-style-type: none"> <li>Remove all test equipment except the DST.</li> <li>Connect any disconnected components, fuses, etc.</li> <li>Using the DST clear DTC information from the ECM.</li> <li>Turn the ignition OFF and wait 30 seconds.</li> <li>Start the engine and operate the vehicle to full operating temperature</li> <li>Observe the MIL</li> <li>Observe engine performance and drivability</li> <li>After operating the engine within the test parameters of DTC-1151 check for any stored codes.</li> </ul> Does the engine operate normally with no stored codes?		System OK	Go to OBD System Check

## DTC 1156-Adaptive Learn Low (Gasoline) (SPN 4236:FMI 1)

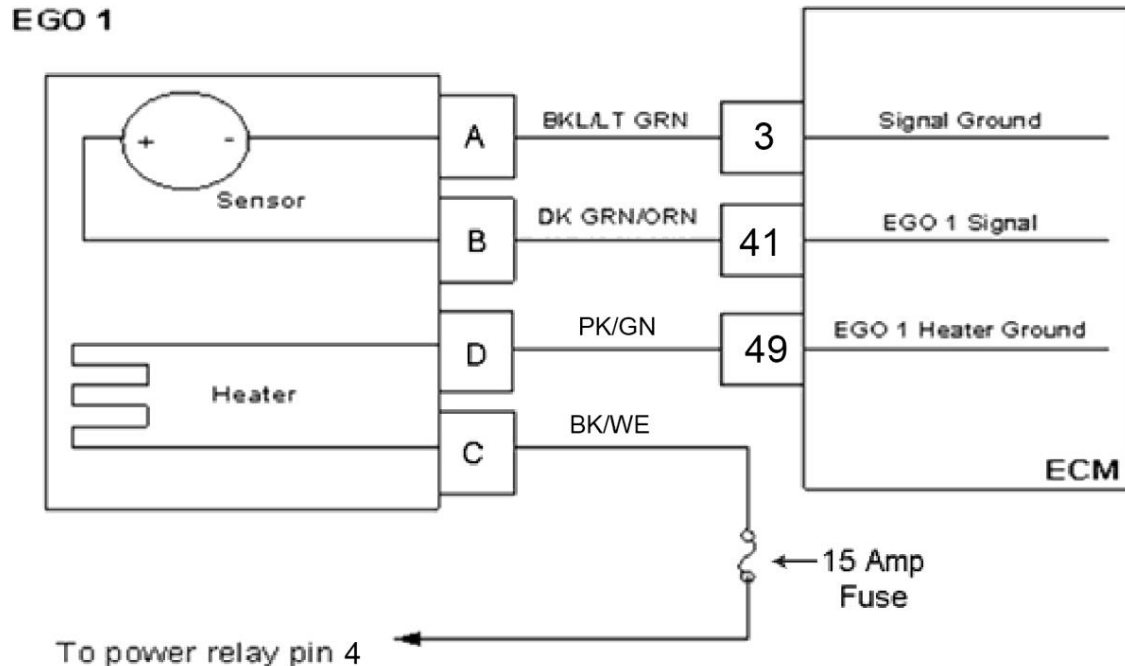

### Conditions for Setting the DTC

- Heated Oxygen Sensor
- Check Condition-Engine running
- Fault Condition-Adaptive multiplier out of range greater than -30%
- MIL-ON

### Circuit Description

The EGO1 sensor is used to determine if the fuel flow to the engine is correct by measuring the oxygen content in the exhaust gas. The ECM uses this information to correct the fuel flow with the Closed Loop multiplier and Adaptive multiplier. This fault will set if the adaptive multiplier exceeds the limits of normal operation. Always run the fuel system diagnostics before using the following diagnostic chart.

### Diagnostic Aid

**Fuel System** High fuel pressure will cause the system to run rich. Fuel pressure is controlled by the ECM using a ground side driver. If the fuel pump is turned on all the time the fuel pressure will increase. Open or leaking injector will cause a rich condition.

**Fuel Quality** A drastic variation in fuel quality may cause the fuel system to run rich.

**Air Filter** A plugged, damaged or modified air filter may cause the system to run rich.

Step	Action	Value(s)	Yes	No
1	<ul style="list-style-type: none"> <li>Perform the On-Board (OBD) System Check? Are any other DTCs present?</li> </ul>		Go to Step (3)	Go to Step (2)
2	<p>Visually and physically check the following items:</p> <ul style="list-style-type: none"> <li>The air intake duct for being collapsed or restricted</li> <li>The air filter for being plugged</li> <li>The EGO sensor is installed securely, and the wire leads not damaged or contacting the secondary ignition wires</li> <li>ECM grounds for being clean and tight.</li> <li>Fuel system diagnostic checks</li> </ul> <p>Was a repair made?</p>		Go to Step (6)	Go to Step (4)
3	<ul style="list-style-type: none"> <li>Diagnose any other DTC codes before proceeding with this chart.</li> </ul> <p>Have any other DTC codes been detected, diagnosed, and repaired?</p>		Go to Step (6)	Go to Step (4)
4	<ul style="list-style-type: none"> <li>Key OFF</li> <li>Disconnect EGO sensor wire harness connector C005</li> <li>Disconnect ECM wire harness connector C001</li> <li>Key ON</li> <li>Using a DVOM check for voltage at EGO 1 connector signal pin A and engine ground</li> </ul> <p>Do you have voltage?</p>		Repair the circuit as necessary. Refer to Wiring Repairs in Engine Electrical.	Go to Step (5)
5	<ul style="list-style-type: none"> <li>Replace EGO sensor</li> </ul> <p>Is the replacement complete?</p>		Go to Step (6)	-
6	<ul style="list-style-type: none"> <li>Remove all test equipment except the DST.</li> <li>Connect any disconnected components, fuses, etc.</li> <li>Using the DST clear DTC information from the ECM.</li> <li>Turn the ignition OFF and wait 30 seconds.</li> <li>Start the engine and operate the vehicle to full operating temperature</li> <li>Observe the MIL</li> <li>Observe engine performance and drivability</li> <li>After operating the engine within the test parameters of DTC-1162 check for any stored codes.</li> </ul> <p>Does the engine operate normally with no stored codes?</p>		System OK	Go to OBD System Check

## DTC 1161-Adaptive Learn High LPG (SPN 4237:FMI 0)

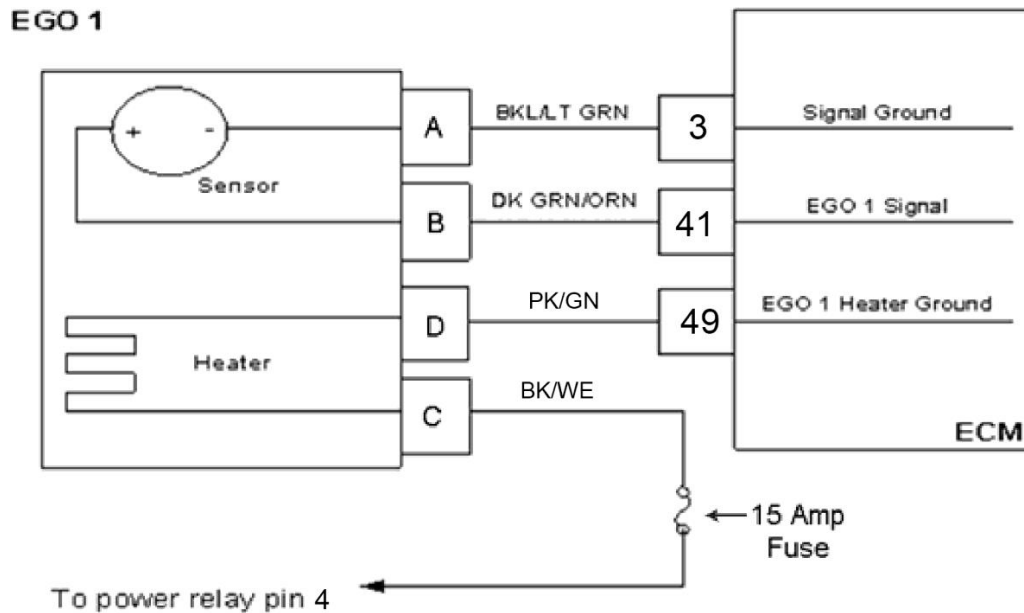

### Conditions for Setting the DTC

- Heated Oxygen Sensor
- Check Condition-Engine Running
- Fault Condition-Adaptive multiplier out of range greater than 30%
- MIL-ON

### Circuit Description

The EGO 1 sensor is used to determine if the fuel flow to the engine is correct by measuring the oxygen content in the exhaust gas. The ECM uses this information to correct the fuel flow with the Closed Loop multiplier and Adaptive multiplier. This fault will set if the adaptive multiplier exceeds the limits of normal operation. Always run the fuel system diagnostic checks before using the following diagnostic chart.

### Diagnostic Aid

**Oxygen Sensor Wire** Heated Oxygen sensor wires may be mis-routed and contacting the exhaust manifold.

**Vacuum Leaks** Large vacuum leaks and crankcase leaks can cause a lean exhaust condition at especially at light load.

**Fuel Mixer** System can be lean due to faulty EPR (Electronic Pressure Regulator) or faulty fuelmixer.

**Fuel Pressure** Low fuel pressure, faulty fuel regulator or contaminated fuel filter can cause fuel the system to run lean.

**Exhaust Leaks** If there is an exhaust leak, outside air can be pulled into the exhaust and past the O2-sensor causing a false lean condition.

**Fuel Quality** Contaminated or spoiled fuel can cause the fuel system to be lean.

**Ground Problem** ECM grounds must be clean, tight and in the proper location.



Step	Action	Value(s)	Yes	No
1	<ul style="list-style-type: none"> <li>Perform the On-Board (OBD) System Check? Are any other DTCs present?</li> </ul>		Go to Step (3)	Go to Step (2)
2	<p>Visually and physically check the following items:</p> <ul style="list-style-type: none"> <li>The air intake duct for being collapsed or restricted</li> <li>The air filter for being plugged</li> <li>System power fuses are good and in the proper location</li> <li>The EGO 1 sensor installed securely, and the wire leads not contacting the exhaust manifold or ignition wires</li> <li>ECM grounds must be clean and tight. Refer to Engine Electrical Power and Ground Distribution</li> <li>Fuel System Diagnostics. Refer to Fuel System Diagnostics</li> </ul> <p>Was a repair made?</p>		Go to Step (9)	Go to Step (4)
3	<ul style="list-style-type: none"> <li>Diagnose any other DTC codes before proceeding with this chart. Always repair existing codes starting with the lowest numerical code set first. Have any other DTC codes been detected, diagnosed and repaired?</li> </ul>		Go to Step (9)	Go to Step (4)
4	<ul style="list-style-type: none"> <li>Disconnect EGO1 connector C005</li> <li>Using a DVOM check for voltage between EGO 1 connector pin B and engine ground</li> <li>Key ON</li> </ul> <p>(CHECK MUST BE MADE WITHIN 30 SECONDS OR BEFORE POWER RELAY SHUTS DOWN)</p> <p>Do you have voltage?</p>	System voltage	Go to Step (5)	Repair the open EGO power circuit as necessary. Refer to Wiring Repairs in Engine Electrical.
5	<ul style="list-style-type: none"> <li>Key OFF</li> <li>Disconnect EGO 1 sensor wire harness connector C005</li> <li>Disconnect ECM wire harness connector C001</li> <li>Key ON</li> <li>Using a high impedance DVOM check for continuity between EGO 1 connector signal pin A and engine ground</li> </ul> <p>Do you have continuity?</p>		Repair the shorted circuit as necessary. Refer to Wiring Repairs in Engine Electrical.	Go to Step (6)

Step	Action	Value(s)	Yes	No
6	<ul style="list-style-type: none"> <li>Using a high impedance DVOM check for continuity between EGO 1 connector signal ground pin C and EGO 1 signal pin A</li> </ul> Do you have continuity?		Repair the shorted circuit as necessary. Refer to Wiring Repairs in Engine Electrical.	Go to Step (7)
7	<ul style="list-style-type: none"> <li>Using a high impedance DVOM check for continuity between EGO 1 heater ground pinD and ECM pin 49</li> </ul> Do you have continuity?		Go to Step (8)	Repair the open EGO heater ground
8	<ul style="list-style-type: none"> <li>Replace EGO 1 sensor</li> </ul> Is the replacement complete?		Go to Step (9)	-
9	<ul style="list-style-type: none"> <li>Remove all test equipment except the DST.</li> <li>Connect any disconnected components, fuses, etc.</li> <li>Using the DST clear DTC information from the ECM.</li> <li>Turn the ignition OFF and wait 30 seconds.</li> <li>Start the engine and operate the vehicle to full operating temperature</li> <li>Observe the MIL</li> <li>Observe engine performance and drivability</li> <li>After operating the engine within the test parameters of DTC-1161 check for any stored codes.</li> </ul> Does the engine operate normally with no stored codes?		System OK	Go to OBD System Check

## DTC 1162-Adaptive Learn Low (LPG) (SPN 4237:FMI 1)

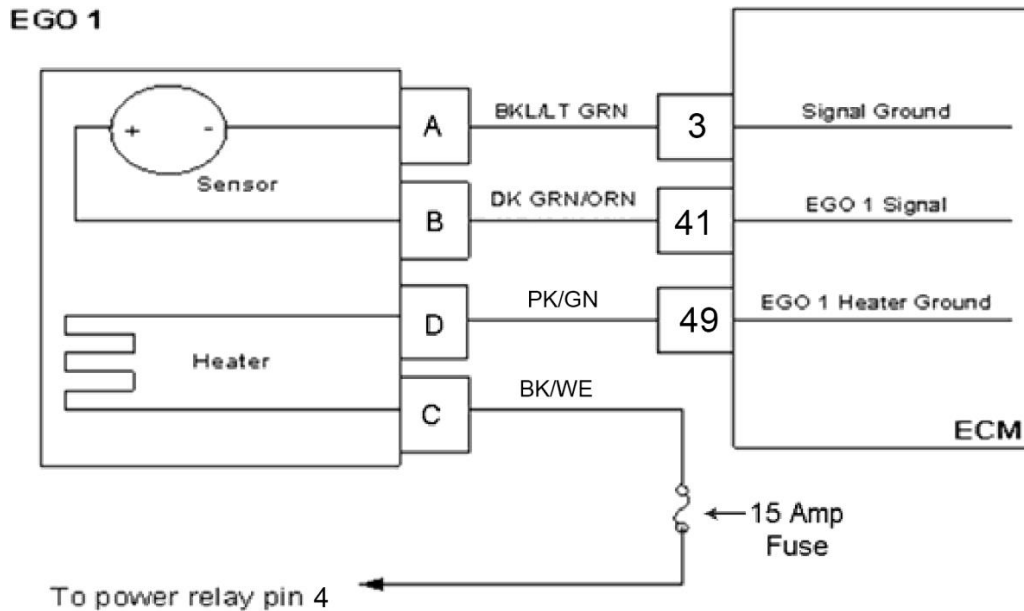

### Conditions for Setting the DTC

- Heated Oxygen Sensor
- Check Condition-Engine running
- Fault Condition-Adaptive multiplier out of range greater than -30%
- MIL-ON

### Circuit Description

The EGO1 sensor is used to determine if the fuel flow to the engine is correct by measuring the oxygen content in the exhaust gas. The ECM uses this information to correct the fuel flow with the Closed Loop multiplier and Adaptive multiplier. This fault will set if the adaptive multiplier exceeds the limits of normal operation. Always run the fuel system diagnostics before using the following diagnostic chart.

### Diagnostic Aid

**Fuel System** High secondary fuel pressure will cause the system to run rich. A worn fuel mixer, faulty EPR (Electronic Pressure Regulator) may also cause the system to run rich.

**Fuel Quality** A drastic variation in fuel quality (very high butane content) may cause the fuel system to run rich. Be sure that the specified HD-5 or HD-10 motor fuel grade propane is used.

**Air Filter** A plugged, damaged or modified air filter may cause the system to run rich.

Step	Action	Value(s)	Yes	No
1	<ul style="list-style-type: none"> <li>Perform the On-Board (OBD) System Check? Are any other DTCs present?</li> </ul>		Go to Step (3)	Go to Step (2)
2	<p>Visually and physically check the following items:</p> <ul style="list-style-type: none"> <li>The air intake duct for being collapsed or restricted</li> <li>The air filter for being plugged</li> <li>The EGO sensor is installed securely, and the wire leads not damaged or contacting the secondary ignition wires</li> <li>ECM grounds for being clean and tight.</li> <li>Fuel system diagnostic checks</li> </ul> <p>Was a repair made?</p>		Go to Step (6)	Go to Step (4)
3	<ul style="list-style-type: none"> <li>Diagnose any other DTC codes before proceeding with this chart.</li> </ul> <p>Have any other DTC codes been detected, diagnosed, and repaired?</p>		Go to Step (6)	Go to Step (4)
4	<ul style="list-style-type: none"> <li>Key OFF</li> <li>Disconnect EGO sensor wire harness connector C005</li> <li>Disconnect ECM wire harness connector C001</li> <li>Key ON</li> <li>Using a DVOM check for voltage at EGO 1 connector signal pin A and engine ground</li> </ul> <p>Do you have voltage?</p>		Repair the circuit as necessary. Refer to Wiring Repairs in Engine Electrical.	Go to Step (5)
5	<ul style="list-style-type: none"> <li>Replace EGO sensor</li> </ul> <p>Is the replacement complete?</p>		Go to Step (6)	-
6	<ul style="list-style-type: none"> <li>Remove all test equipment except the DST.</li> <li>Connect any disconnected components, fuses, etc.</li> <li>Using the DST clear DTC information from the ECM.</li> <li>Turn the ignition OFF and wait 30 seconds.</li> <li>Start the engine and operate the vehicle to full operating temperature</li> <li>Observe the MIL</li> <li>Observe engine performance and drivability</li> <li>After operating the engine within the test parameters of DTC-1162 check for any stored codes.</li> </ul> <p>Does the engine operate normally with no stored codes?</p>		System OK	Go to OBD System Check

## DTC 1163 - Adaptive Learn High NG

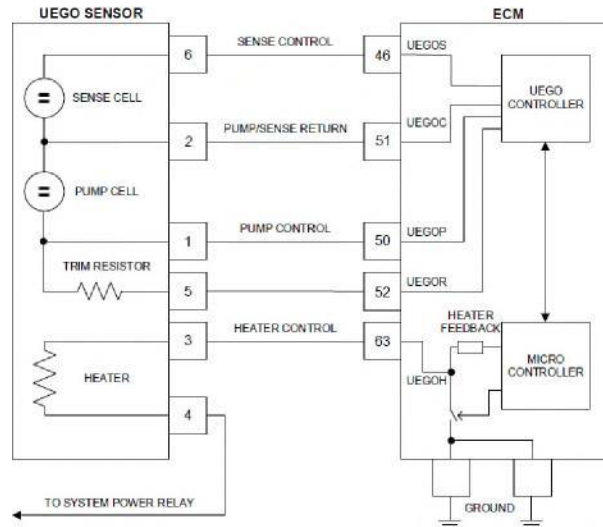

### Conditions for Setting the DTC

- Check Condition: Engine Running
- Fault Condition: Adaptive multiplier out of range greater than 30% while running on natural gas
- MIL: ON

### Circuit Description

The UEGO sensor is used to determine if the fuel flow to the engine is correct by measuring the oxygen content in the exhaust gas. The ECM uses this information to correct the fuel flow with the Closed Loop multiplier and Adaptive multiplier. This fault will set if the adaptive multiplier exceeds the limits of normal operation. Always run the fuel system diagnostic checks before using the following diagnostic chat.

### Diagnostic Aid

**Oxygen Sensor Wire** - Heated Oxygen sensor wires may be mis-routed and contacting the exhaust manifold.

**Vacuum Leaks Large** - vacuum leaks and crankcase leaks can cause a lean exhaust condition at especially at light load.

**Fuel Mixer** - System can be lean due to faulty EPR (Electronic Pressure Regulator) or faulty fuel mixer.

**Fuel Pressure** - Low fuel pressure, faulty fuel regulator or contaminated fuel filter can cause fuel the system to run lean

**Exhaust Leaks** - If there is an exhaust leak, outside air can be pulled into the exhaust and past the O2 sensor causing a false lean condition.

**Fuel Quality** - Contaminated or spoiled fuel can cause the fuel system to be lean.

**Ground Problem** - ECM grounds must be clean, tight and in the proper location.

### Note:

- If one bank shows high adaptive and the other is low, the O2 sensor leads are crossed. Trace those wires back to their ECM's are correct accordingly.

## DTC 1164 - Adaptive Learn Low NG

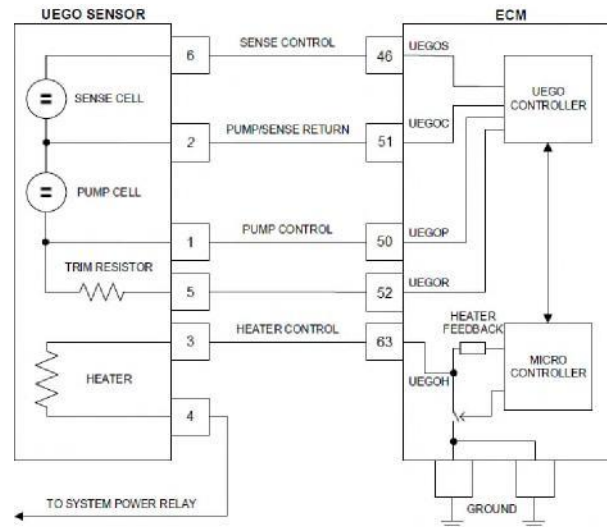

### Conditions for Setting the DTC

- Check Condition: Engine running
- Fault Condition: Adaptive multiplier out of range greater than -30% while running on natural gas
- MIL: ON

### Circuit Description

The UEGO sensor is used to determine if the fuel flow to the engine is correct by measuring the oxygen content in the exhaust gas. The ECM uses this information to correct the fuel flow with the Closed Loop multiplier and Adaptive multiplier. This fault will set if the adaptive multiplier exceeds the limits of normal operation. Always run the fuel system diagnostics before using the following diagnostic chart.

### Diagnostic Aid

**Fuel System** - High secondary fuel pressure will cause the system to run rich. A worn fuel mixer, faulty EPR (Electronic Pressure Regulator) may also cause the system to run rich.

**Fuel Quality** - A drastic variation in fuel quality (very high butane content) may cause the fuel system to run rich. Be sure that the specified HD-5 or HD-10 fuel grade propane is used.

**Air Filter** - A plugged, damaged or modified air filter may cause the system to run rich.

#### Note:

- If one bank shows high adaptive and the other is low, the O2 sensor leads are crossed. Trace those wires back to their ECM's are correct accordingly.

## DTC 1165-LPG Catalyst Monitor (SPN 3050:FMI 11)

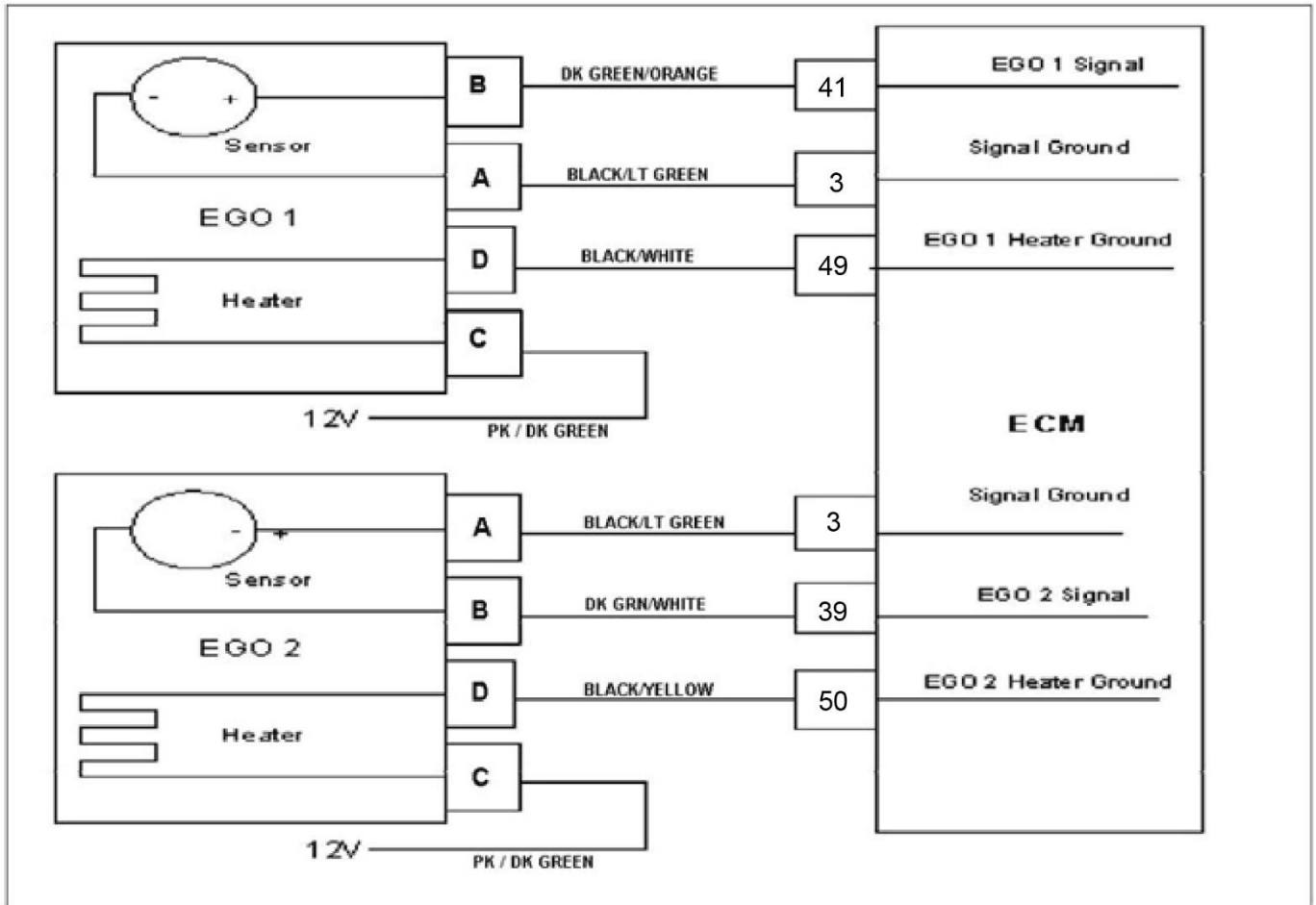

### Conditions for Setting the DTC

- Catalyst Function
- Check condition- Engine running
- Fault condition- EGO 1 signal = EGO 2 signal for 100 updates
- MIL- On during active fault and for 1 second after active fault
- Adaptive- Disabled during active fault

### Circuit Description

The ECM uses EGO 1 and EGO 2 sensor signals to diagnose problems with the catalyst muffler. When the signals for EGO 1 & EGO 2 are similar it may indicate a problem with the catalyst.

### Diagnostic Aids

Always diagnose any other troubles, stored along with DTC 420 first. Check for and eliminate any exhaust leaks prior to replacing catalyst muffler. Look for exhaust leaks at the catalyst muffler inlet and tail pipes. Clear this trouble code after repairing exhaust leaks and recheck for code.

## DTC 1171-EPR Pressure Higher Than Expected (SPN 520260:FMI 0)

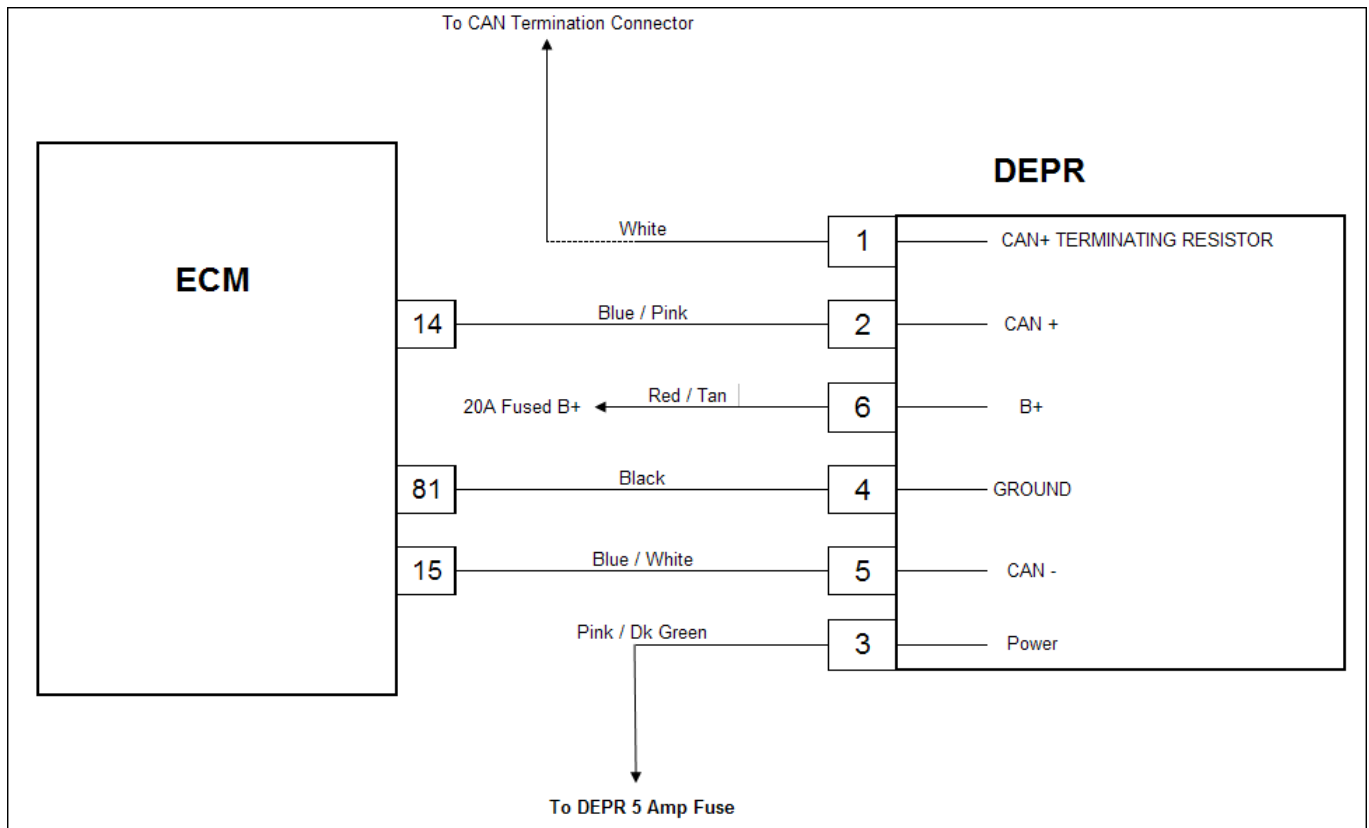

### Conditions for Setting the DTC

- EPR delivery pressure
- Check condition-Engine running or cranking
- MIL-ON during active fault
- Fault condition-EPR actual pressure greater than 1.5 inches above commanded pressure
- Adaptive disabled
- Closed loop disabled

### Circuit Description

The EPR (Electronic Pressure Regulator) unit measures and controls the amount of fuel that is able to pass to the fuel mixer. This code will set in the event the actual pressure is 1.5 inches water pressure higher than the actual commanded pressure. Adaptive learn is disabled and the MIL command is ON during this fault.

### Diagnostic Aid

Always run the fuel system diagnostic pressure check before proceeding with the following diagnostic chart. High secondary fuel pressure due to a worn or damaged primary or secondary seat may cause this fault to set.



Step	Action	Value(s)	Yes	No
1	Did you perform the On-Board (OBD) System Check?	-	Go to Step (2)	Go to OBD System Check Section
2	Did you run the fuel pressure diagnostic test in the fuel system diagnostic section with no problems found?		Go to Step (4)	Go to Step (3)
3	<ul style="list-style-type: none"> <li>Run the EPR pressure test in the fuel system diagnostic section</li> </ul> Did the EPR pass the fuel pressure test specifications?		Go to Step (4)	Follow the EPR service recommendations from the fuel pressure test chart.
4	<ul style="list-style-type: none"> <li>Inspect the EPR electrical connector pins C018 for damage, corrosion or contamination.</li> </ul> Did you find a problem?		Repair the circuit as necessary. Refer to wire harness repair section.	Go to Step (5)
5	<ul style="list-style-type: none"> <li>Replace or repair the EPRs</li> </ul> the replacement complete?		Go to Step (6)	-
6	<ul style="list-style-type: none"> <li>Remove all test equipment except the DST.</li> <li>Connect any disconnected components, fuses, etc.</li> <li>Using the DST clear DTC information from the ECM.</li> <li>Turn the ignition OFF and wait 30 seconds.</li> <li>Start the engine and operate the vehicle to full operating temperature</li> <li>Observe the MIL</li> <li>Observe engine performance and drivability</li> <li>After operating the engine within the test parameters of DTC1171 check for any stored codes.</li> </ul> Does the engine operate normally with no stored codes?		System OK	Go to OBD System Check

**DTC 1172-EPR Pressure Lower Than Expected (SPN 520260:FMI 1)**  
**DTC 354 EPR Pressure Lower than expected (SPN 520260 FMI 1)**

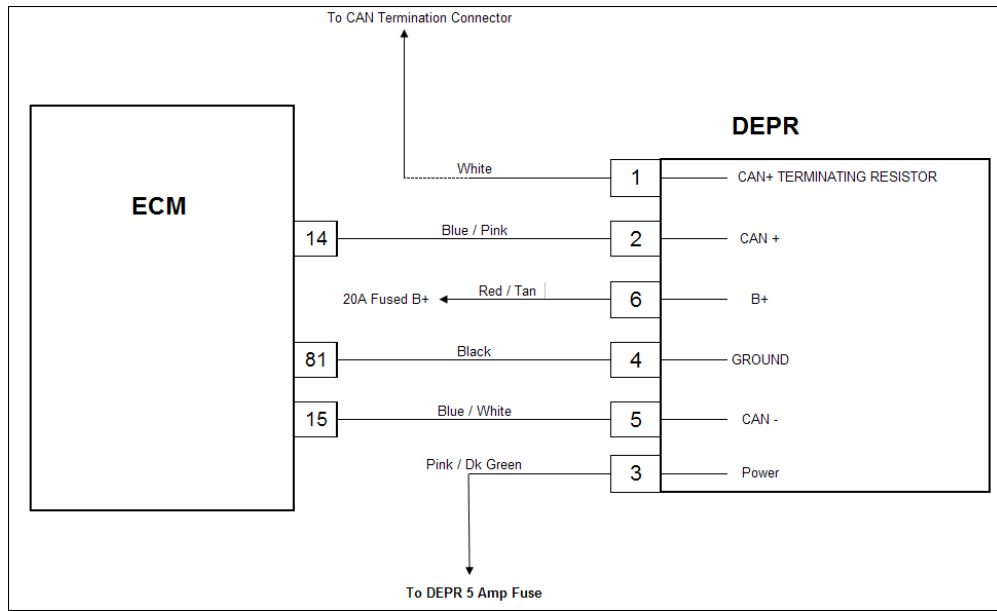

**Conditions for Setting the DTC**

- Low EPR delivery pressure
- Check condition-Engine running or cranking
- MIL-ON during active fault
- Fault condition-EPR actual pressure less than 1.5 inches below commanded pressure
- Adaptive disabled
- Closed loop disabled

**Circuit Description**

The Electronic Pressure Regulator (EPR) monitors and controls the fuel flow to the mixer. This fault code triggers when the actual pressure falls 1.5 inches of water column below the commanded pressure. The fault indicates that the device has reached its minimum operational limit, and the commanded pressure cannot be achieved, likely due to insufficient delivery or supply pressure.

**Diagnostic Aid**

Monitor the “***Gaseous Pressure Target***” and “***Gaseous Pressure Actual***” in 4G Display to confirm if your actual pressure is lower than target. If yes, determine if this is due to low fuel supply or pressure, a defective component (i.e. closed lock off valve).

Improperly wired fuel lock off valves or valves that are not functioning could cause this code.

Gaseous pressure target	0.00	"H2O
Gaseous pressure actual	0.00	"H2O

Step	Action	Value(s)	Yes	No
1	Did you perform the On-Board (OBD) System Check?	-	Go to Step (2)	Go to OBD System Check Section
2	Measure incoming fuel pressure into the EPR. Is the fuel pressure 7 to 11 inches of water column?	7-11"WC	Go to Step (4)	Go to Step (3)
3	Check fuel lock off electrical and mechanical to ensure it is allowing fuel to pass. Is the fuel lock off opening correctly and allowing fuel to flow?		Go to Step (4)	Inspect application fuel supply pressure and volume, correct as needed.
4	<ul style="list-style-type: none"> <li>Inspect the EPR electrical connector C018 for damage, corrosion or contamination.</li> </ul> Did you find a problem?		Repair the circuit as necessary. Refer to wire harness repair section.	Go to Step (5)
5	<ul style="list-style-type: none"> <li>Replace or repair the EPR</li> </ul> Is the replacement complete?		Go to Step (6)	-
6	<ul style="list-style-type: none"> <li>Remove all test equipment except the DST.</li> <li>Connect any disconnected components, fuses, etc.</li> <li>Using the DST clear DTC information from the ECM.</li> <li>Turn the ignition OFF and wait 30 seconds.</li> <li>Start the engine and operate the vehicle to full operating temperature</li> <li>Observe the MIL</li> <li>Observe engine performance and drivability</li> <li>After operating the engine within the test parameters of DTC1172 check for any stored codes.</li> </ul> Does the engine operate normally with no stored codes?		System OK	Go to OBD System Check

## DTC 1173-EPR Communication Lost (SPN 520260:FMI 31)

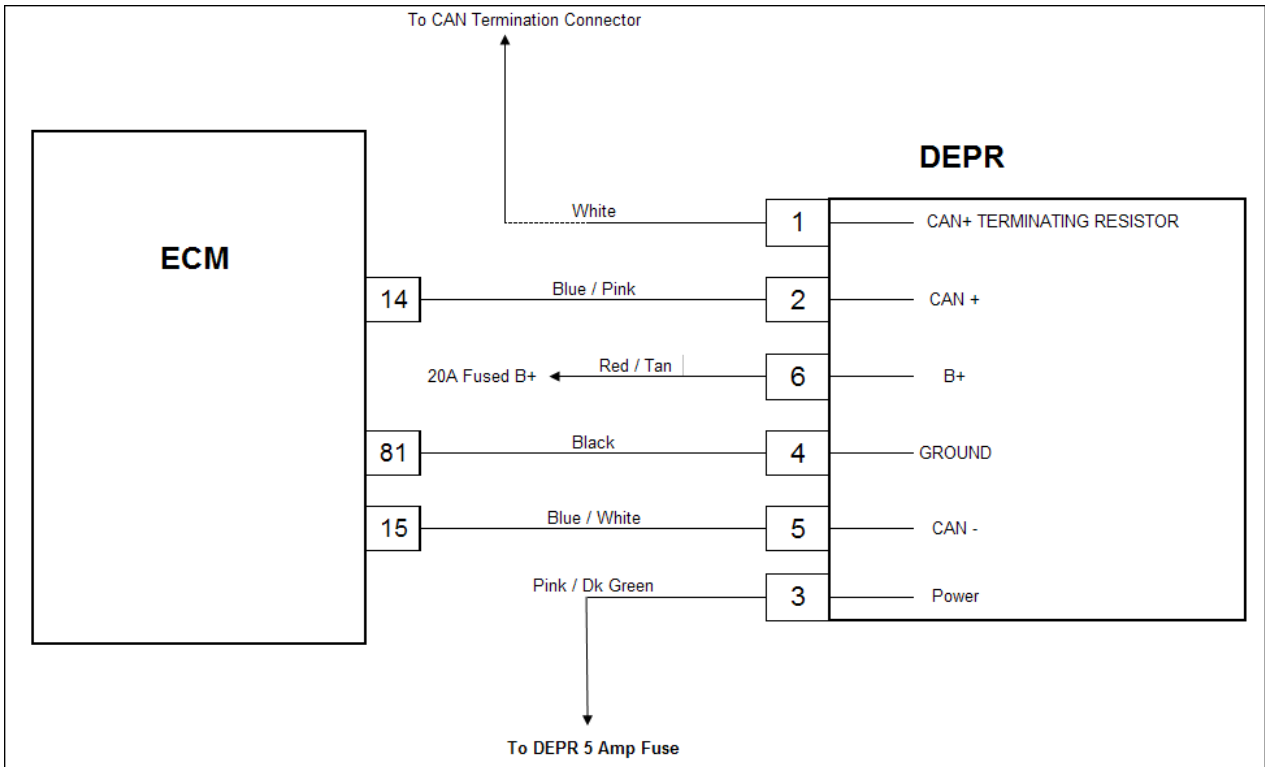

### Conditions for Setting the DTC

- EPR CAN communication
- Check condition-Engine running or cranking
- MIL-On during active fault
- Fault condition-No packets received within 500 ms
- Adaptive disabled

### Circuit Description

The EPR (Electronic Pressure Regulator) unit measures and controls the amount of fuel that is able to pass to the fuel mixer. This code will set in the event communication with the ECM is lost. The MIL command is on.

Step	Action	Value(s)	Yes	No
1	Did you perform the On-Board (OBD) System Check?	-	Go to Step (2)	Go to OBD System Check Section
2	<ul style="list-style-type: none"> <li>Key ON</li> <li>DST (Diagnostic Scan Tool) connected in the system data mode</li> <li>Clear DTC1173</li> <li>Key OFF</li> <li>Key ON, and attempt to start the engine</li> </ul> Does DTC1173 re-set?		Go to step (3)	Intermittent problem. Go to Intermittent Problem section in the electrical section of this manual.
3	<ul style="list-style-type: none"> <li>Key OFF</li> <li>Disconnect EPR electrical connector C018</li> <li>Key ON</li> <li>Using a DVOM check for system power between EPR connector pin 7 and engine ground</li> </ul> (Be sure to activate relay control ON using the DST function or check before ECM relay control times out) Do you have power?	System battery voltage	Go to step (7)	Go to step (4)
4	<ul style="list-style-type: none"> <li>Check the 10A (F5) fusels the fuse open?</li> </ul>		Go to step (5)	Go to step (6)
5	<ul style="list-style-type: none"> <li>Replace the F5 fuse</li> </ul> Is the replacement complete?		Go to step (17)	-
6	<ul style="list-style-type: none"> <li>Using a DVOM check for system power at power relay terminal 3</li> </ul> (Be sure to activate relay control ON using the DST function or check before ECM relay control times out) Do you have power?	System battery voltage	Repair the open circuit between power relay pin 3 and EPR pin 7 Go to step (17)	Repair the power relay circuit as required Go to step (17)
7	<ul style="list-style-type: none"> <li>Using a DVOM check for continuity between EPR connector pin 6 and engine ground</li> </ul> Do you have continuity?		Go to step (8)	Repair the open ground circuit as necessary. Refer to wiring repairs in engine electrical

Step	Action	Value(s)	Yes	No
8	<ul style="list-style-type: none"> <li>Key OFF</li> <li>Disconnect the EPR connector C018</li> <li>Disconnect the ECM connector C001</li> <li>Using a DVOM check for continuity between EPR pin 5 and ECM pin 15</li> </ul> Do you have continuity?		Go to step (9)	Repair the open circuit as necessary. Refer to wiring repairs in engine electrical
9	<ul style="list-style-type: none"> <li>Using a DVOM check for continuity between EPR pin 2 and ECM pin 14</li> </ul> Do you have continuity?		Go to step (10)	Repair the open circuit as necessary. Refer to wiring repairs in engine electrical
10	<ul style="list-style-type: none"> <li>Using a DVOM check for continuity between EPR pin 4 and ECM pin 81</li> </ul> Do you have continuity?		Go to step (11)	Repair the open circuit as necessary. Refer to wiring repairs in engine electrical
11	<ul style="list-style-type: none"> <li>Using a DVOM check for continuity between EPR pin 3 and B+</li> </ul> Do you have continuity?		Go to step (12)	Repair the open circuit as necessary. Refer to wiring repairs in engine electrical
12	<ul style="list-style-type: none"> <li>Using a DVOM check for continuity between EPR pin 6 and B+</li> </ul> Do you have continuity?		Go to step (13)	Repair the open circuit as necessary. Refer to wiring repairs in engine electrical
13	<ul style="list-style-type: none"> <li>Disconnect DST from the DLC connector C014</li> <li>Using a DVOM check for continuity between engine ground and EPR pin 4</li> </ul> Do you have continuity?		Repair the shorted to ground CAN circuit as necessary. Refer to wiring repairs in engine electrical	Go to step (14)
14	<ul style="list-style-type: none"> <li>Replace the EPR</li> </ul> Is the replacement complete?		Go to step (15)	–

Step	Action	Value(s)	Yes	No
15	<ul style="list-style-type: none"> <li>Remove all test equipment and reconnect the DST.</li> <li>Connect any disconnected components, fuses, etc.</li> <li>Using the DST clear DTC information from the ECM.</li> <li>Turn the ignition OFF and wait 30 seconds.</li> <li>Start the engine and operate the vehicle to full operating temperature</li> <li>Observe the MIL</li> <li>Observe engine performance and drivability</li> <li>After operating the engine within the test parameters of DTC1173 check for any stored codes.</li> </ul> <p>Does DTC1173 still re-set?</p>		Go to step (16)	System OK
16	<ul style="list-style-type: none"> <li>Replace the ECM</li> </ul> <p>Is the replacement complete?</p>		Go to step (17)	–
17	<ul style="list-style-type: none"> <li>Remove all test equipment except the DST.</li> <li>Connect any disconnected components, fuses, etc.</li> <li>Using the DST clear DTC information from the ECM.</li> <li>Turn the ignition OFF and wait 30 seconds.</li> <li>Start the engine and operate the vehicle to full operating temperature</li> <li>Observe the MIL</li> <li>Observe engine performance and drivability</li> <li>After operating the engine within the test parameters of DTC1173 check for any stored codes.</li> </ul> <p>Does the engine operate normally with no stored codes?</p>		System OK	Go to OBD System Check

## DTC 1174-EPR Supply Voltage High (SPN 520260:FMI 3)

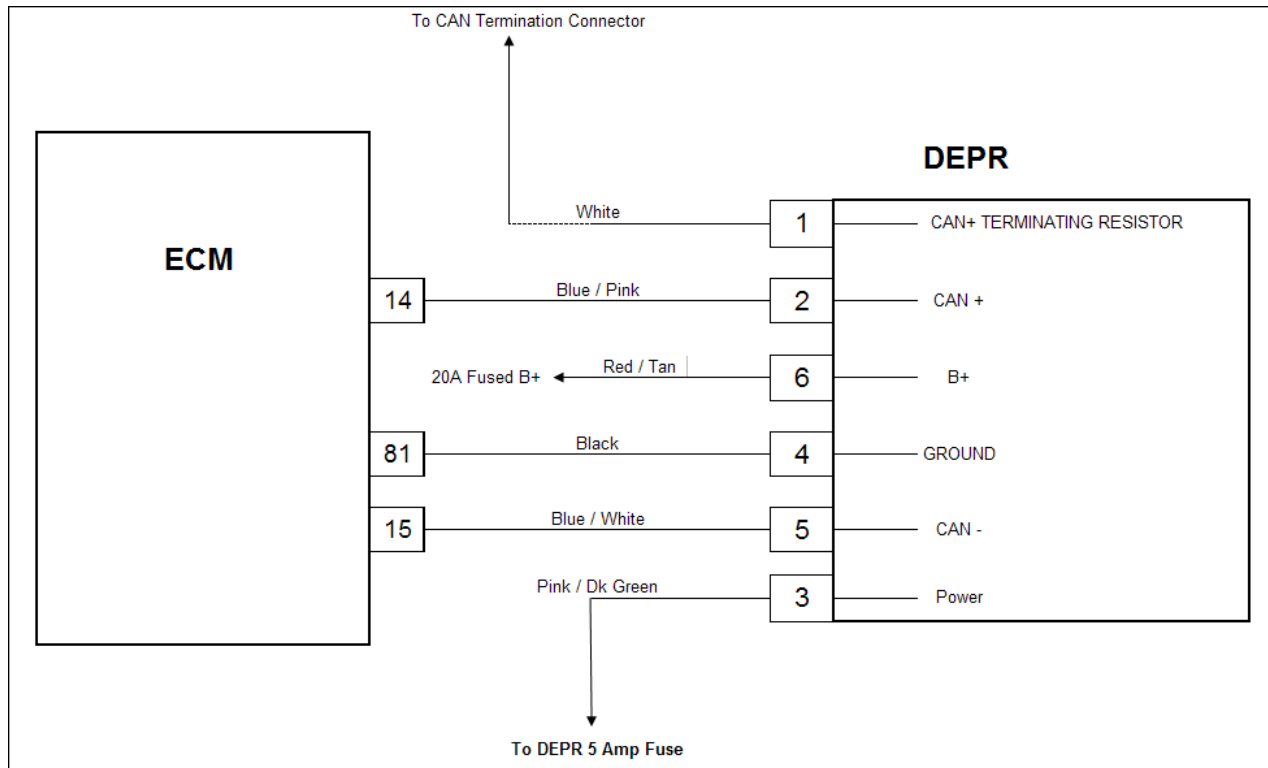

### Conditions for Setting the DTC

- EPR supply voltage
- Check condition-Engine running or cranking
- MIL-ON during active fault
- Fault condition-internal EPR supply voltage too high
- Adaptive disabled
- Closed loop disabled

### Circuit Description

The EPR (Electronic Pressure Regulator) unit measures and controls the amount of fuel that is able to pass to the fuel mixer. Pressure readings are sent over the CAN to the ECM and in return the ECM sends back a control signal to the EPR to increase or decrease pressure for precise mixture control. This code will set if the EPR internal supply voltage is too high.

### Diagnostic Aid

This DTC indicates abnormal EPR internal voltages that are not measurable externally. Check the system charging voltage to be sure this DTC and other over voltage DTCs are not present. Repair the charging system if it is found to be out of specification for high charge voltage. In the event of multiple code sets, always start the diagnostic repair with the lowest numerical value DTC first.



Step	Action	Value(s)	Yes	No
1	Did you perform the On-Board (OBD) System Check?	-	Go to Step (2)	Go to OBD System Check Section
2	<ul style="list-style-type: none"> <li>DST connected and in the system data mode</li> <li>Engine running</li> <li>Check the system battery voltage.</li> </ul> Is the charging voltage within specifications?		Go to Step (3)	Repair the charging system
3	<ul style="list-style-type: none"> <li>Using a DVOM compare the system battery voltage to the DST display.</li> </ul> Is the voltage reading within 1 volt between the two of them?	1 volt	Go to Step (4)	Go to Step (5)
4	<ul style="list-style-type: none"> <li>Replace the EPR</li> </ul> Is the replacement complete?		Go to Step (6)	-
5	<ul style="list-style-type: none"> <li>Replace the ECM</li> </ul> Is the replacement complete?		Go to Step (6)	-
6	<ul style="list-style-type: none"> <li>Remove all test equipment except the DST.</li> <li>Connect any disconnected components, fuses, etc.</li> <li>Using the DST clear DTC information from the ECM.</li> <li>Turn the ignition OFF and wait 30 seconds.</li> <li>Start the engine and operate the vehicle to full operating temperature</li> <li>Observe the MIL</li> <li>Observe engine performance and drivability</li> <li>After operating the engine within the test parameters of DTC1174 check for any stored codes.</li> </ul> Does the engine operate normally with no stored codes?		System OK	Go to OBD System Check

## DTC 1175-EPR Supply Voltage Low (SPN 520260:FMI 4)

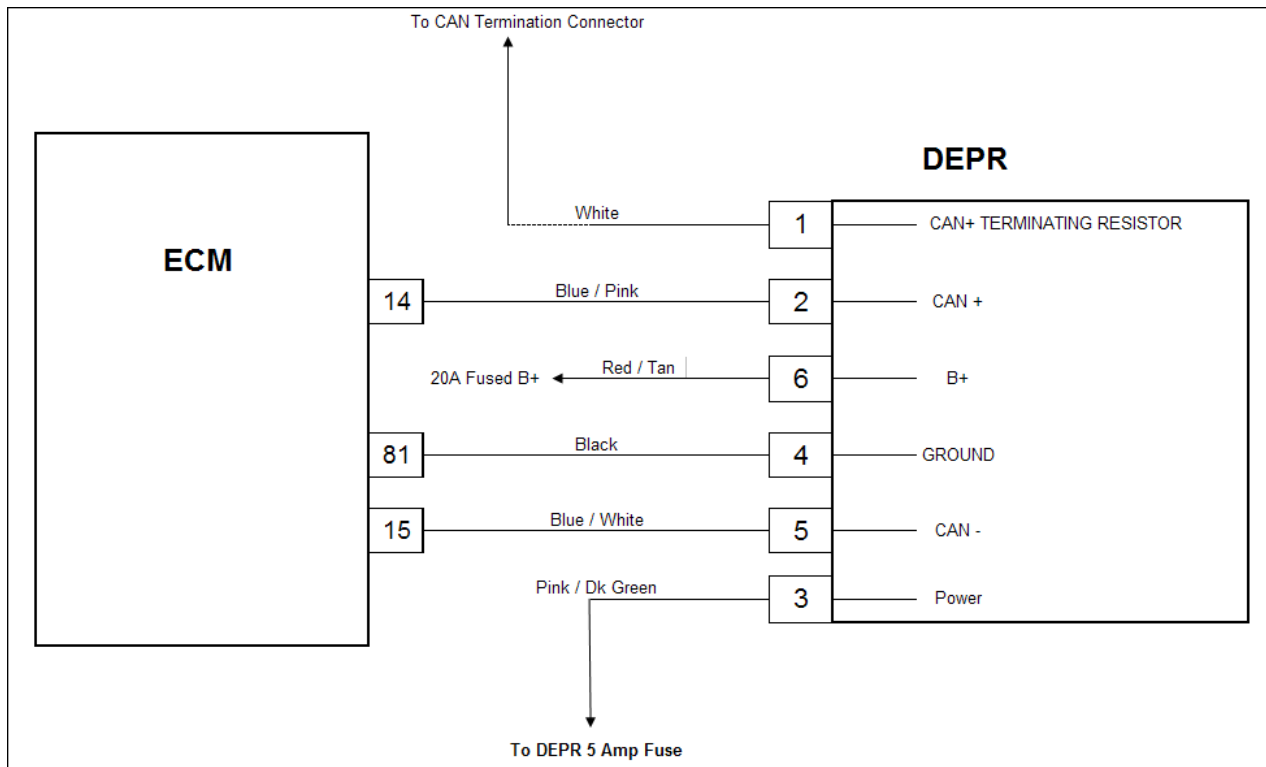

### Conditions for Setting the DTC

- EPR supply voltage
- Check condition-Engine running or cranking
- MIL-ON during active fault
- Fault condition-EPR internal supply voltage low
- Adaptive disabled

### Circuit Description

The EPR (Electronic Pressure Regulator) unit measures and controls the amount of fuel that is able to pass to the fuel mixer. Pressure readings are sent over the CAN to the ECM and in return the ECM sends back a control signal to the EPR to increase or decrease pressure for precise mixture control. This code will set if the internal EPR supply voltage is low. Adaptive is disabled and the MIL command is ON.

### Diagnostic Aid

This DTC indicates abnormal EPR internal voltages that are not measurable externally. Check the system charging voltage to be sure this DTC and other low voltage DTCs are not present. Repair the charging system if it is found to be out of specification for low charge voltage. In the event of multiple code sets, always start the diagnostic repair with the lowest numerical value DTC first.

Step	Action	Value(s)	Yes	No
1	Did you perform the On-Board (OBD) System Check?	-	Go to Step (2)	Go to OBD System Check Section
2	<ul style="list-style-type: none"> <li>DST connected and in the system data mode</li> <li>Engine running</li> <li>Check the system battery voltage.</li> </ul> Is the charging voltage within specifications?		Go to Step (3)	Repair the charging system
3	<ul style="list-style-type: none"> <li>Key OFF</li> <li>Disconnect the EPR electrical connector C018</li> <li>Using a DVOM check for power between the EPR connector pin 7 and engine ground.</li> <li>Key ON</li> <li>Record the voltage reading.</li> </ul> (Be sure to activate relay control ON using the DST function or check before ECM relay control times out) <ul style="list-style-type: none"> <li>Using a DVOM check the system battery power at the battery terminals and record the voltage reading.</li> </ul> Are the recorded voltage readings within 1 volt of each other?		Go to Step (6)	Go to Step (4)
4	<ul style="list-style-type: none"> <li>Inspect the EPR connector and F5 fuse holder terminals for damage corrosion or contamination</li> </ul> Did you find a problem?		Correct the problem as necessary. See wiring harness repair in the electrical section of this manual	Go to Step (5)
5	<ul style="list-style-type: none"> <li>Check the power relay circuit. Check the power relay connections for damage corrosion or contamination</li> </ul> Did you find a problem?		Correct the problem as necessary. See wiring harness schematic in the electrical section of this manual	-

Step	Action	Value(s)	Yes	No
6	<ul style="list-style-type: none"> <li>• Key OFF</li> <li>• Disconnect the ECM connector C001</li> <li>• Using a DVOM check the resistance reading between EPR connector pin 6 and ECM connector pin 69 and 81.</li> </ul> (Do not forget to subtract any resistance value that may be present in your test cables) Is the resistance reading less than 0.5 ohms?	Less than 0.5 ohms	Go to Step (7)	Repair the poor EPR power ground circuit. See wiring harness repair in the electrical section of this manual
7	<ul style="list-style-type: none"> <li>• Replace the EPR</li> </ul> Is the replacement complete?		Go to Step (8)	–
8	<ul style="list-style-type: none"> <li>• Remove all test equipment except the DST.</li> <li>• Connect any disconnected components, fuses, etc.</li> <li>• Using the DST clear DTC information from the ECM.</li> <li>• Turn the ignition OFF and wait 30 seconds.</li> <li>• Start the engine and operate the vehicle to full operating temperature</li> <li>• Observe the MIL</li> <li>• Observe engine performance and drivability</li> <li>• After operating the engine within the test parameters of DTC1175 check for any stored codes.</li> </ul> Does DTC 1175 still re-set?		Go to Step (9)	System OK
9	<ul style="list-style-type: none"> <li>• Replace the ECM</li> </ul> Is the replacement complete?		Go to Step (10)	–
10	<ul style="list-style-type: none"> <li>• Remove all test equipment except the DST.</li> <li>• Connect any disconnected components, fuses, etc.</li> <li>• Using the DST clear DTC information from the ECM.</li> <li>• Turn the ignition OFF and wait 30 seconds.</li> <li>• Start the engine and operate the vehicle to full operating temperature</li> <li>• Observe the MIL</li> <li>• Observe engine performance and drivability</li> <li>• After operating the engine within the test parameters of DTC1175 check for any stored codes.</li> </ul> Does the engine operate normally with no stored codes?		System OK	Go to OBD System Check

## DTC 1176-EPR Internal Actuator Fault (SPN 520260:FMI 12)

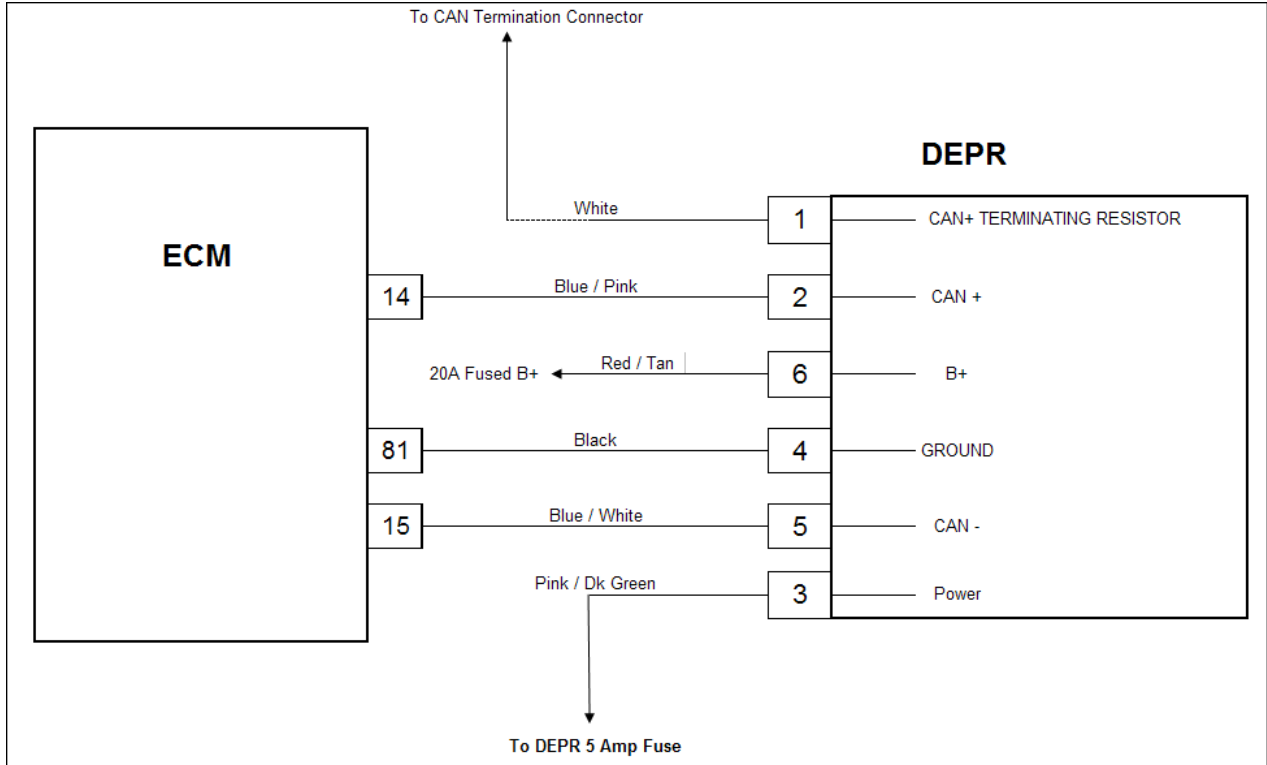

### Conditions for Setting the DTC

- EPR internal actuator test
- Check condition-Engine running or cranking
- MIL-ON during active fault
- Fault condition-Failed actuator
- Adaptive disabled

### Circuit Description

The EPR (Electronic Pressure Regulator) unit measures and controls the amount of fuel that is able to pass to the fuel mixer. Pressure readings are sent over the CAN to the ECM and in return the ECM sends back a control signal to the EPR to increase or decrease pressure for precise mixture control. This code will set if the ECM detects an internal actuator fault with the EPR. In the event of multiple code sets, always start the diagnostic repair with the lowest numerical value DTC first. In most instances the EPR will need to be replaced in the event of this code set.

Step	Action	Value(s)	Yes	No
1	Did you perform the On-Board (OBD) System Check?	-	Go to Step (2)	Go to OBD System Check Section
2	<ul style="list-style-type: none"> <li>DST connected and in the system data mode.</li> <li>Check for any other current or active DTCs</li> </ul> Does the DST show any other codes set?		Go to Step (3)	Go to Step (6)
3	<ul style="list-style-type: none"> <li>Repair any other DTCs set starting with the lowest DTC number first.</li> </ul> Have the other DTCs set been corrected?		Go to Step (4)	-
4	<ul style="list-style-type: none"> <li>Remove all test equipment except the DST.</li> <li>Connect any disconnected components, fuses, etc.</li> <li>Using the DST clear DTC information from the ECM.</li> <li>Turn the ignition OFF and wait 30 seconds.</li> <li>Start the engine and operate the vehicle to full operating temperature.</li> <li>Observe the MIL.</li> <li>Observe engine performance and drivability</li> <li>After operating the engine within the test parameters of DTC1176 check for any stored codes.</li> </ul> Does DTC 1176 still re-set?		Go to Step (5)	System OK
5	<ul style="list-style-type: none"> <li>Replace the EPR</li> </ul> Is the replacement complete?		Go to Step (6)	-
6	<ul style="list-style-type: none"> <li>Remove all test equipment except the DST.</li> <li>Connect any disconnected components, fuses, etc.</li> <li>Using the DST clear DTC information from the ECM.</li> <li>Turn the ignition OFF and wait 30 seconds.</li> <li>Start the engine and operate the vehicle to full operating temperature.</li> <li>Observe the MIL.</li> <li>Observe engine performance and drivability</li> <li>After operating the engine within the test parameters of DTC1176 check for any stored codes.</li> </ul> Does the engine operate normally with no stored codes?		System OK	Go to OBD System Check

## DTC 1177-EPR Internal Circuitry Fault (SPN 520260:FMI 12)

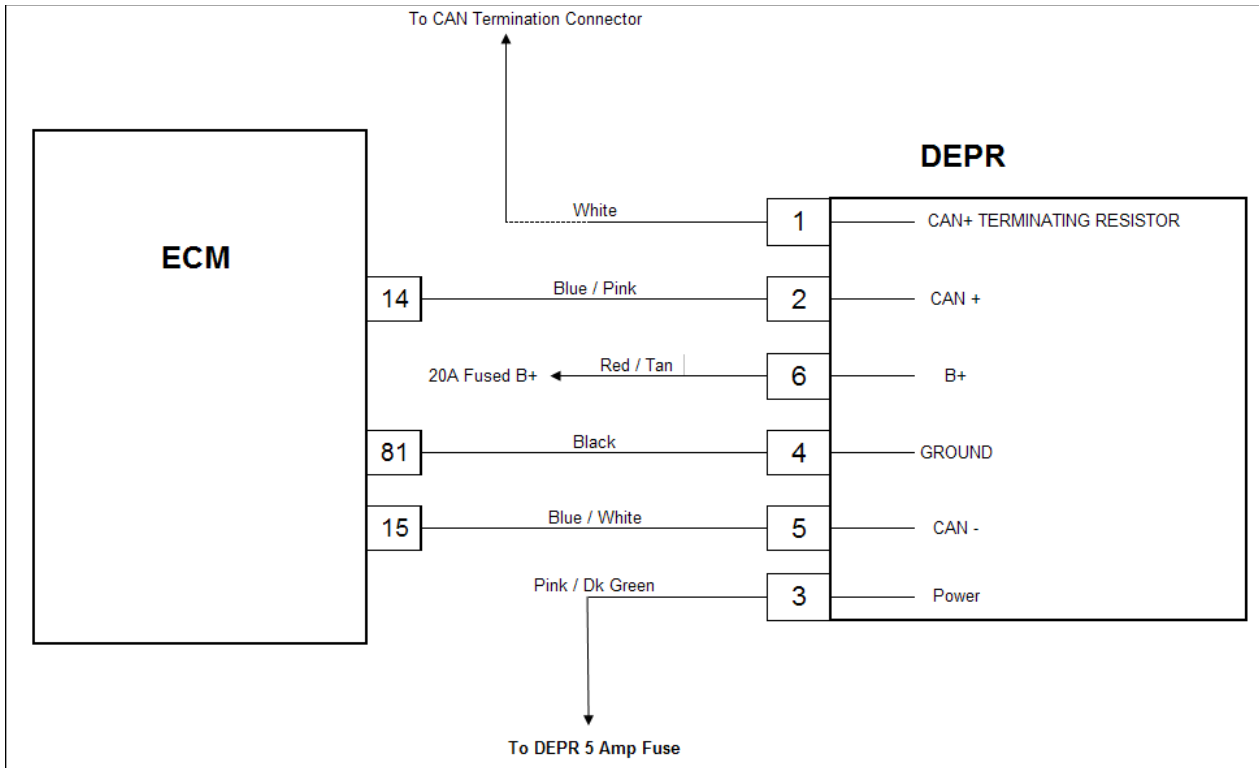

### Conditions for Setting the DTC

- EPR internal circuitry test
- Check condition-Engine running or cranking
- MIL-ON during active fault
- Fault condition-
- Adaptive disabled

### Circuit Description

The EPR (Electronic Pressure Regulator) unit measures and controls the amount of fuel that is able to pass to the fuel mixer. Pressure readings are sent over the CAN to the ECM and in return the ECM sends back a control signal to the EPR to increase or decrease pressure for precise mixture control. This code will set if the ECM detects an internal circuitry fault in the EPR. In the event of multiple code sets, always start the diagnostic repair with the lowest numerical value DTC first. In most instances the EPR will need to be replaced in the event of this code set.

Step	Action	Value(s)	Yes	No
1	Did you perform the On-Board (OBD) System Check?	-	Go to Step (2)	Go to OBD System Check Section
2	<ul style="list-style-type: none"> <li>DST connected and in the system data mode</li> <li>Check for any other current or active DTCs</li> </ul> Does the DST show any other codes set?		Go to Step (3)	Go to Step (6)
3	<ul style="list-style-type: none"> <li>Repair any other DTCs set starting with the lowest DTC number first</li> </ul> Have the other DTCs set been corrected?		Go to Step (4)	-
4	<ul style="list-style-type: none"> <li>Remove all test equipment except the DST.</li> <li>Connect any disconnected components, fuses, etc.</li> <li>Using the DST clear DTC information from the ECM.</li> <li>Turn the ignition OFF and wait 30 seconds.</li> <li>Start the engine and operate the vehicle to full operating temperature</li> <li>Observe the MIL</li> <li>Observe engine performance and drivability</li> <li>After operating the engine within the test parameters of DTC1177 check for any stored codes.</li> </ul> Does DTC 1177 still re-set?		Go to Step (5)	System OK
5	<ul style="list-style-type: none"> <li>Replace the EPR</li> </ul> Is the replacement complete?		Go to Step (6)	-
6	<ul style="list-style-type: none"> <li>Remove all test equipment except the DST.</li> <li>Connect any disconnected components, fuses, etc.</li> <li>Using the DST clear DTC information from the ECM.</li> <li>Turn the ignition OFF and wait 30 seconds.</li> <li>Start the engine and operate the vehicle to full operating temperature</li> <li>Observe the MIL</li> <li>Observe engine performance and drivability</li> <li>After operating the engine within the test parameters of DTC1177 check for any stored codes.</li> </ul> Does the engine operate normally with no stored codes?		System OK	Go to OBD System Check



## DTC 1178-EPR Internal Communication Fault (SPN 520260:FMI 12)

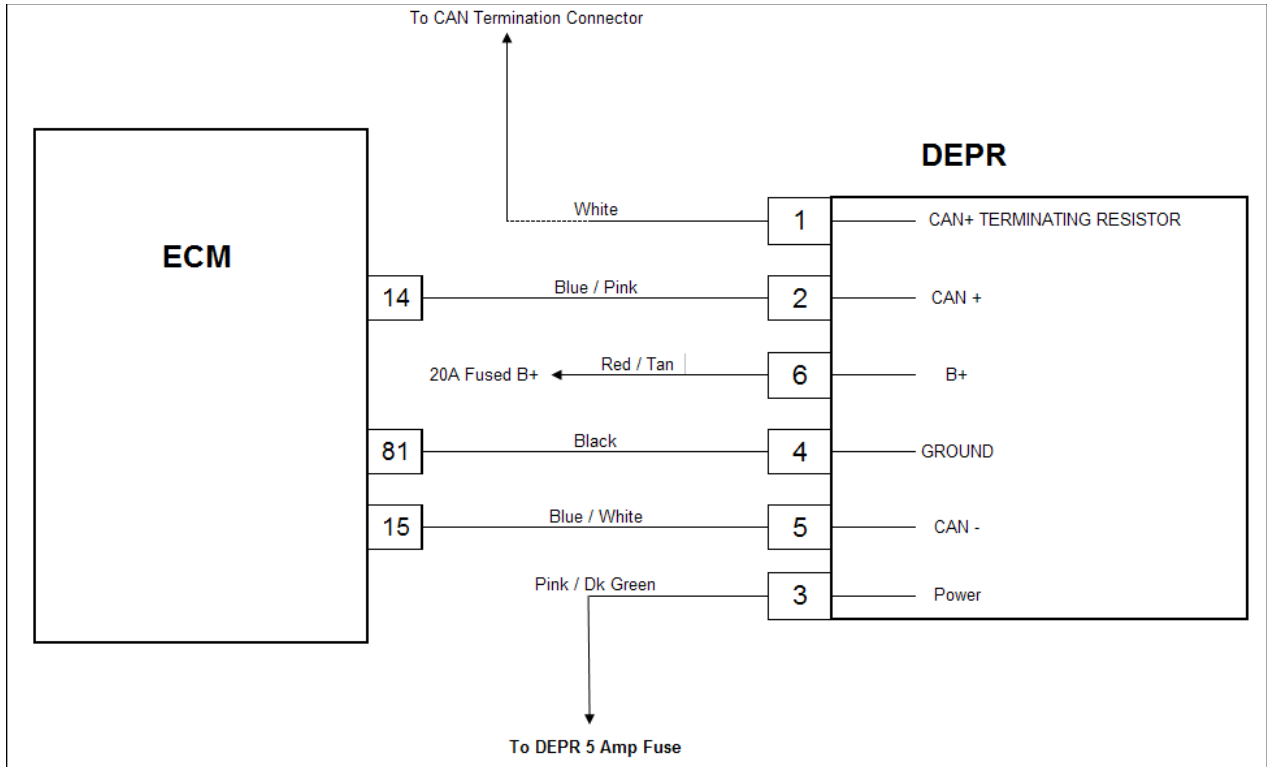

### Conditions for Setting the DTC

- EPR internal communication test
- Check condition-Engine running or cranking
- MIL-ON during active fault
- Fault condition-
- Adaptive disabled

### Circuit Description

The EPR (Electronic Pressure Regulator) unit measures and controls the amount of fuel that is able to pass to the fuel mixer. Pressure readings are sent over the CAN to the ECM and in return the ECM sends back a control signal to the EPR to increase or decrease pressure for precise mixture control. This code will set if the ECM detects an internal communication error in the EPR. In the event of multiple code sets, always start the diagnostic repair with the lowest numerical value DTC first. In most instances the EPR will need to be replaced in the event of this code set.

Step	Action	Value(s)	Yes	No
1	Did you perform the On-Board (OBD) System Check?	-	Go to Step (2)	Go to OBD System Check Section
2	<ul style="list-style-type: none"> <li>DST connected and in the system data mode.</li> <li>Check for any other current or active DTCs</li> </ul> Does the DST show any other codes set?		Go to Step (3)	Go to Step (6)
3	<ul style="list-style-type: none"> <li>Repair any other DTCs set starting with the lowest DTC number first.</li> </ul> Have the other DTCs set been corrected?		Go to Step (4)	-
4	<ul style="list-style-type: none"> <li>Remove all test equipment except the DST.</li> <li>Connect any disconnected components, fuses, etc.</li> <li>Using the DST clear DTC information from the ECM.</li> <li>Turn the ignition OFF and wait 30 seconds.</li> <li>Start the engine and operate the vehicle to full operating temperature.</li> <li>Observe the MIL.</li> <li>Observe engine performance and drivability</li> <li>After operating the engine within the test parameters of DTC1178 check for any stored codes.</li> </ul> Does DTC 1178 still re-set?		Go to Step (5)	System OK
5	<ul style="list-style-type: none"> <li>Replace the EPR</li> </ul> Is the replacement complete?		Go to Step (6)	-
6	<ul style="list-style-type: none"> <li>Remove all test equipment except the DST.</li> <li>Connect any disconnected components, fuses, etc.</li> <li>Using the DST clear DTC information from the ECM.</li> <li>Turn the ignition OFF and wait 30 seconds.</li> <li>Start the engine and operate the vehicle to full operating temperature.</li> <li>Observe the MIL</li> <li>Observe engine performance and drivability</li> <li>After operating the engine within the test parameters of DTC1178 check for any stored codes.</li> </ul> Does the engine operate normally with no stored codes?		System OK	Go to OBD System Check

## DTC 1330 - Intake Backfire Detected

### Conditions for Setting the DTC

- Check Condition: Key On
- Fault Condition: Intake backfires  $\geq 4$  events
- MIL: ON
- Adaptive: Disabled during active fault

### Fault description

The ECM detects IAT readings which may indicate an intake backfire. This may be caused by improper fuel-air mixtures, worn ignition components, improper valve lash settings, engine timing and possibly bad sensors.

The DTC is set to trigger an event based off of any change in IAT<sup>1</sup> greater than 25 deg F/sec greater than 20ms. Once an event is counted, it will be stored in a histogram visible on the "Service" page in 4G Display. The diagnostic is set around these event counts within a timeframe.

<sup>1</sup>This is a calculated IATdt which is a filtered signal. You cannot directly relate this to IAT or rIAT in a bplt for 1:1 visual if it will trigger.

### Diagnostic Aids

- Capture **ALL fault code history** in MASTER and SLAVE ECM's
- Download **ALL fault code flight data recorders** from MASTER and SLAVE ECM's
- Download **ALL fault snapshot** from MASTER and SLAVE ECM's
- Download **Backfire Histogram** from MASTER and SLAVE ECM's (located on Service page)
- **Inspect spark plugs for water ingress/corrosion** from the top side (coil side)
- **Ignition coil wire harness inspection** (closely looking at pin conditions)
- **Spark Plug Resistance Value<sup>2</sup>** = 3.5 to 7 kOhm (Acceptable resistance value)
- **Verify Crank Position Sensor gap<sup>2</sup>** --> Shim as needed

### <sup>2</sup>M Series only

Below is a list of issues that may indicate a backfire event has occurred.

- Damaged or melted MAP sensor
- DTC 111 (IAT Higher than Expected 1)
- DTC 127 (IAT Higher than Expected 2)
- DTC 112 (IAT Voltage Low)

# DTC 1330 - Intake Backfire Detected

EDIS ECI Target Communications \_ □ ×

File Page Flash Comm Port Plot/Log Settings Help

**EControls** Service MIL ← → ↻ REC Error opening ECom module in HandleConnect, (error code 251)

| No | **No** | No | | No | | No |

Hour Last Commit | 0.000 Hour Hst 1 | 0.000 Hour Hst 2 | 0.000

---

**Intake Backfire Monitoring**

Intake backfire detection mode Disabled ▾

Intake backfire IATdt limit  deg F/sec

Intake backfire MAP limit  psia

Intake backfire latch time  ms

Intake backfire unlatch time  ms

IATdt  deg F/sec

IATdt max (key cycle)  deg F/sec

**Intake Backfire Histogram (Lifetime)**

Speed (rpm)	MAP load (psia)				
	0.0	0.0	0.0	0.0	0.0
0	0	0	0	0	0
0	0	0	0	0	0
0	0	0	0	0	0
0	0	0	0	0	0
0	0	0	0	0	0
0	0	0	0	0	0
0	0	0	0	0	0

Intake Backfire Occurrences

Total intake backfires (lifetime)  occurrences

**Intake Backfire Histogram (Recent)**

Speed (rpm)	MAP load (psia)				
	0.0	0.0	0.0	0.0	0.0
0	0	0	0	0	0
0	0	0	0	0	0
0	0	0	0	0	0
0	0	0	0	0	0
0	0	0	0	0	0
0	0	0	0	0	0
0	0	0	0	0	0

Intake Backfire Occurrences

Total intake backfires (recent)  occurrences

Cumulative time since reset  hours

Intake backfire action request Press to select action... ▾

**Intake Backfire Events (Recent)**

Time (hours)	Occurrences
0	0
0	0
0	0
0	0

## DTC 1330 - Intake Backfire Detected

Step	Action	Value(s)	Yes	No
1	Did you perform the On-Board (OBD) System Check?	-	Go to Step (2)	Go to OBD System Check
2	<p>When did the backfire occur (date, time, engine hours)?</p> <p>What conditions did the backfire occur in (engine starting, load step, etc)</p> <p>Was the backfire through the intake or exhaust?</p> <p>Did the backfire occur on the master or slave side of the engine (right or left)?</p> <p>Are any fault codes active or historic in the master AND slave ECM?</p> <p>Download all fault snapshots and flight data recorder ("FDR") and save for later.</p>		Go to Step (3)	
3	<p>Inspect for any obvious issues that may have caused the event.</p> <ul style="list-style-type: none"> <li>a. Fuel system</li> <li>b. Ignition system</li> <li>c. Electrical</li> <li>d. Base Engine</li> <li>e. Application</li> </ul>		System OK	Go to Step (4)
4	<p>Ignition Coil Wire Harness Inspection</p> <ul style="list-style-type: none"> <li>a. Inspect the coil harness to engine harness connector as well as the ignition coil to harness connector for incorrectly pinned circuits.</li> <li>b. Inspect for connections that are not fully seated.</li> <li>c. Inspect for pushed back, loose, damaged, bent, or spread terminals.</li> <li>d. Inspect for damage to the wiring.</li> <li>e. Inspect for water ingress into the connectors.</li> <li>f. Inspect for debris in the terminals or circuit.</li> <li>g. Pay close attention to turbo boots for any signs of oil leak, weep, or seep onto ignition harness connectors.</li> </ul>		System OK	Go to Step (5)
5	<p>Remove each ignition coil from the engine one at a time.</p> <ul style="list-style-type: none"> <li>a. Inspect and document coils that are not fully seated or loose.</li> <li>b. Inspect and document ignition coil boots that may have torn or fragmented off before or during removal.</li> <li>c. Inspect for water or coolant around the body of the ignition coil.</li> <li>d. Inspect for presence of dielectric grease.</li> </ul>		System OK	Go to Step (6)

Step	Action	Value(s)	Yes	No
6	Remove each spark plug from engine one at a time. a. Inspect for contamination (oil, fuel, coolant, other) b. Inspect spark plug condition using the guide below as a visual.	Replace spark plugs at 750 hours if not already replaced.	System OK	Go to Step (7)
7	Measure resistance of spark plug. a. Replace if the resistance is outside the acceptable value. b. Measurement requires very firm contact with the probes and may require scratching the surface to get a valid measurement.	3.5-7 kOhm = Acceptable resistance value	System OK	Go to Step (8)
8	<b>*M-Series Engine Only</b> Locate the crank sensor on bottom left-hand side of flywheel housing and perform a crank sensor gap verification.	Crank sensor specification is 0.110" +/- 0.015	System OK	Go to Step (9)
9	In cases where the engine is within 100 hours of a valve lash PM, remove valve covers from engine and perform a valve clearance inspection. Adjust as required and reassemble per instructions in the service manual.	Valve lash <b>MUST BE performed on cold engine</b>	System OK	Go to Step (10)
10	<b>Important - Reassemble the spark plugs, ignition coils, and ignition coil boots on the exact opposite cylinder which they were removed. Meaning install cylinder 1 ignition system parts onto cylinder 7 during the reassembly procedure.</b>  Install spark plugs. a. Apply dielectric grease* to spark plug tip. b. Replace spark plugs if any visual issues were noted during the inspection. Apply dielectric grease* to spark plug boots. Install and torque ignition coils and boots. Connect electrical connections to ignition coils. a. Ensure the connections are tight and secured properly.  Replace any damaged components found during the evaluation.  *Use Permatex Dielectric grease #81150 or equivalent	Replace spark plugs if the spark plugs have 750 hours or more of operation		Go to Step (11)

Step	Action	Value(s)	Yes	No
11	<p>When you are ready to start the engine connect the 4G Display software to the engine wire harness diagnostic link connector.</p> <p>Turn VSW (B+) on to the engine so the 4G display connects to the engine ECM's.</p> <p>Load the DWELL plot file template into the 4G display software.</p> <p>Start a plot file recording.</p> <p>Start Engine.</p> <p>Monitor engine for any abnormal conditions, fault codes, fuel pressure expected vs actual.</p> <ul style="list-style-type: none"> <li>a. Specifically, monitor fuel trims on both the primary and secondary side ECM's to ensure they are within acceptable limits.</li> <li>b. A DTC will not likely set until +/- 35%, ideally the fuel trims will be +/- 15%</li> </ul> <p>Run the engine for 10 minutes while recording the plot file data.</p> <p>Save plot file data.</p>			

## DTC 1351 - Spark Plug or Coil Failure

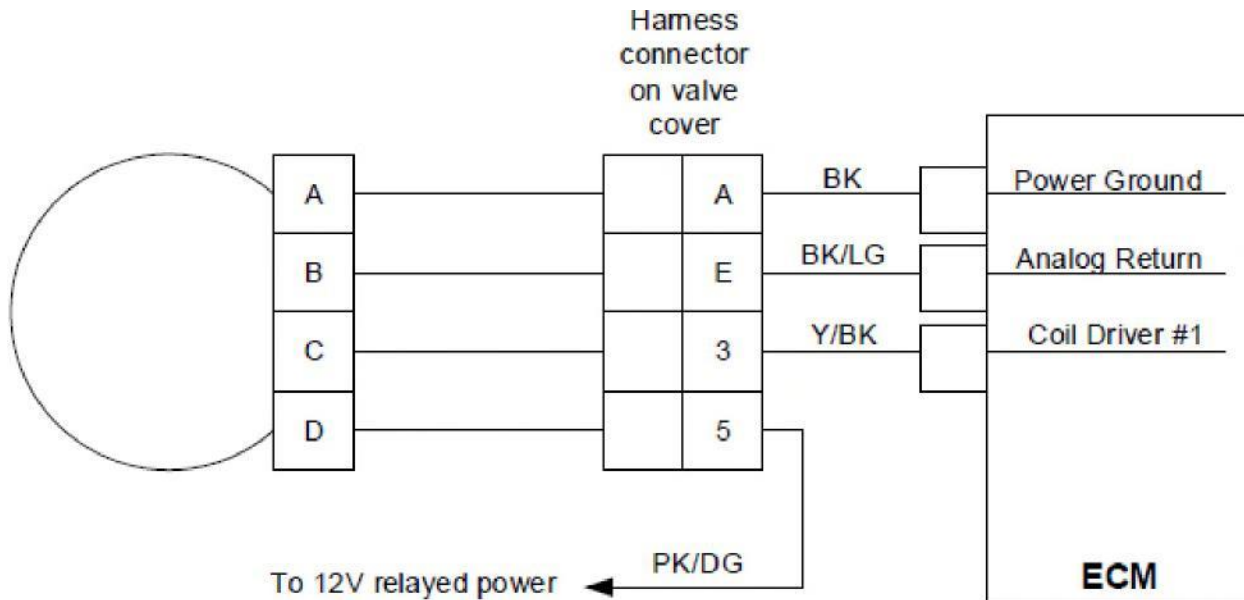

### Conditions for setting the DTC

- Key on, Engine on
- Fault conditions: Ignition/spark drive circuitry (internal to the ECM) is overheating.
- MIL: ON
- Engine Shutdown

### Fault Description

Coil driver #1 (correlates to DTC 1351) fires either the 1st cylinder in the firing order or the 1st cylinder in the block order depending on the configuration of the 'Injector/Spark.

Diagnostic Numbering' scheme as set in calibration. Drivers 2-10 (correlating to DTCs 13521360) follow in-kind.

### Diagnostic Aids:

- Check plug gap on the cylinder associated with the fault.
- Check for loose connections at the coil and spark plugs. Look for evidence of charring or arcing around the spark plugs.
- Check coil resistance and verify that it is within specifications. Look for a short internal to the coil.
- Ensure the use of high-quality coils without a history of internal arcing or other failures.
- Verify that ambient conditions are not exceeding 85C on a continuous basis or 125C for short intervals. If so, verify that this fault stops occurring when ambient temperatures are lower.
- Verify the dwell time set in the diagnostic calibration is not set too long and that adaptive dwell is enabled.



## DTC 1511-Auxiliary Analog PU 1 High Voltage (SPN 701:FMI 3)

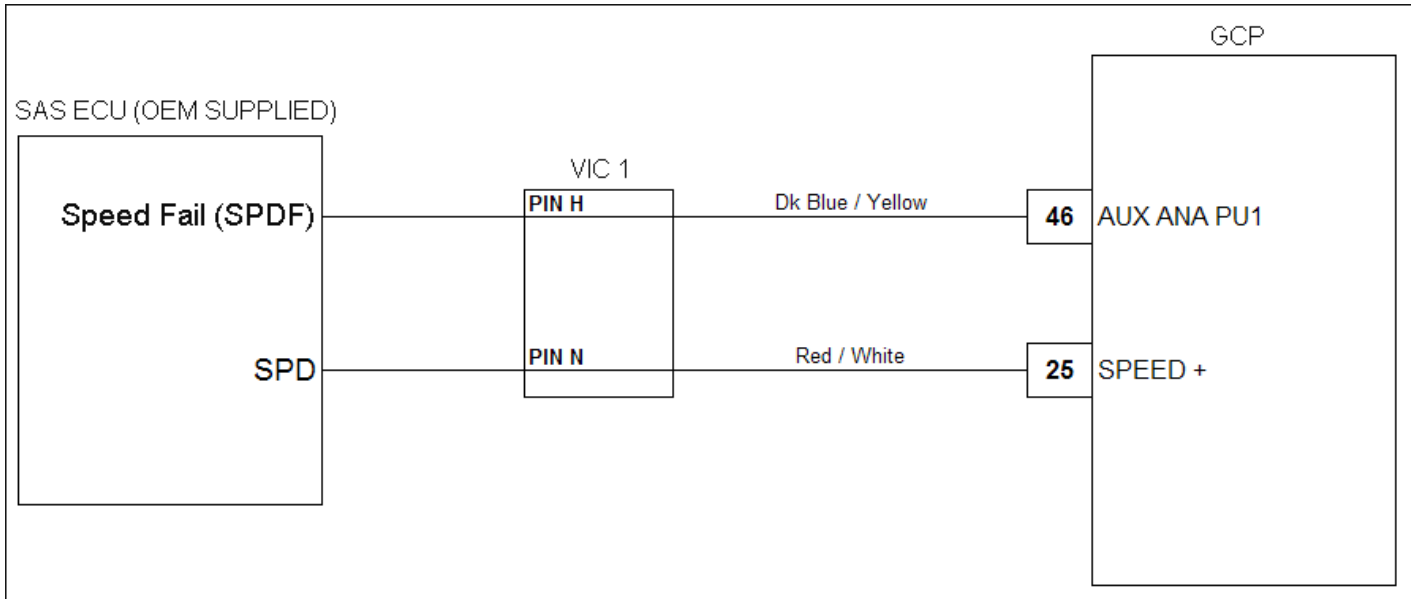

### Conditions for setting the DTC

- Voltage on Aux Analog PU1 is 5.0v or greater for longer than 1 second
- Wiring issue between Vehicle Interface Connector 1 (VIC 1) and pin 46 at ECM
- Wiring issue between VIC 1 and OEM supplied speed computer
- MIL light on during fault
- Power Derate 2 enabled

### Circuit Description

The AUX PU1 is pulled-up to 5 VDC inside the ECM therefore; if SPDF input becomes an open-circuit into the ECU the input will remain at 5 VDC. The OEM supplied controller grounds the SPDF circuit when the vehicle is stopped. As a result, the fault is configured in the ECU on an AUX PU1 High Voltage state if voltage reached 5.0v for longer than 1 second. This informs the technician that the circuit is open. The technician should verify the wiring is good from the OEM supplied speed computer to the ECM module. If the wiring is ok, the problem is likely in the OEM system.

STEP	Action	Value(s)	Yes	No
1	Did you perform the On-Board (OBD) System Check?	–	Go to Step (2)	Go to OBD System Check Section
2	<ul style="list-style-type: none"> <li>• Key ON</li> <li>• DST (Diagnostic Scan Tool) connected</li> </ul> On the Raw Volts page, check the value for Aux_ana_PU1  Does the DST display 4.9v or greater?	4.9v or Greater	Go to Step (3)	Intermittent problem Go to Intermittent section  Check for bad wiring in the circuit
3	<ul style="list-style-type: none"> <li>• Key off and battery disconnected</li> <li>• Provide a good ground circuit to pin H at VIC 1</li> </ul> Reconnect battery and turn the key on, does the page still indicate 4.9v or greater?	4.9v or Greater	Go to Step (4)	Repairing circuit issue between OEM supplied speed computer and Pin H at the VIC 1
4	<ul style="list-style-type: none"> <li>• Key off and battery disconnected</li> <li>• Remove ground circuit installed in step 3, reinstall OEM wiring</li> <li>• Provide a good ground circuit to Pin 46 at the GCP Connector</li> </ul> Reconnect battery and turn the key on, does the raw volts page still indicate 4.9v or greater?	4.9v or Greater	Refer to OEM for diagnosis of speed control system	Repair wire circuit issue between VIC 1 and GCP pin 46

**DTC 1552-Aux Digital 1 Low Voltage (SPN 707:FMI 041)**  
**DTC 1552: AUX digital 1 low voltage (SPN 520222: FMI 04)**

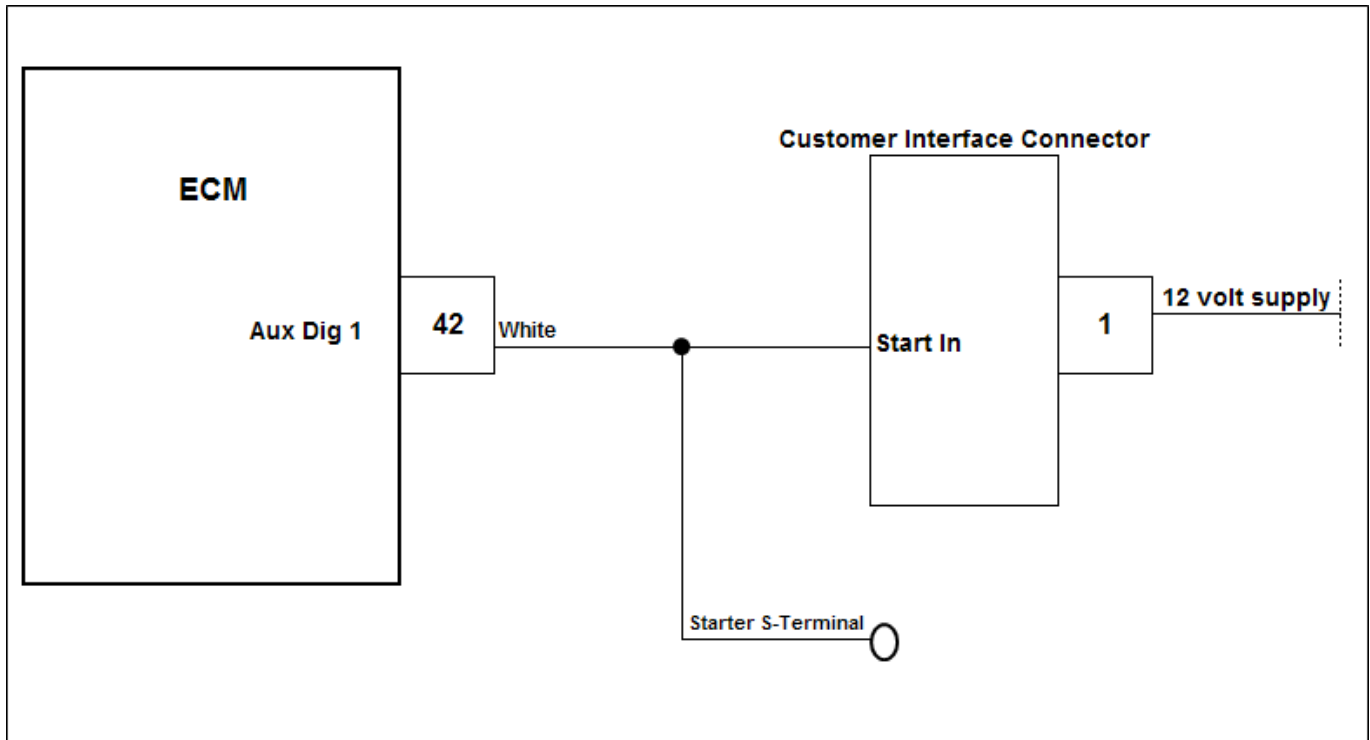

**Conditions for setting the DTC**

- Engine RPM between 60 rpm and 220 rpm
- Voltage at Aux Dig 1 at the ECM (Pin 42) is less than 4 volts for greater than 1 second
- Check Condition- Engine cranking

**Circuit Description**

Aux Digital 1 is used to detect when the operator is cranking the engine by monitoring the key switch “start” position voltage potential. When the operator attempts to start the engine a 12-volt signal is sent through the customer interface connector “start in” terminal. The circuit carries the voltage to the S-Terminal of the starter which will begin engine cranking. The circuit has a splice which also carries the voltage to terminal 42 of the ECM “Aux Dig 1”. When B+ voltage is present at terminal 42 Aux Dig 1, the ECM knows the engine is cranking. This fault code is used to detect a circuit malfunction in which the engine is cranking and there is less than 4 volts at terminal 42 at the ECM.

STEP	Action	Value(s)	Yes	No
1	Did you perform the On-Board(OBD) System Check?	–	Go to Step (2)	Go to OBD System Check Section
2	<ul style="list-style-type: none"> <li>• Engine Cranking</li> <li>• DST (Diagnostic Scan Tool) connected on the Raw Volts page</li> </ul> <p>Does AUX_DIG1_Raw Displayless than 4 volts?</p>	< 4 Volts	Go to Step (3)	ECM Defective, Replace ECM
3	<ul style="list-style-type: none"> <li>• Engine Cranking</li> <li>• Connect DVOM as instructed below</li> </ul> <p>Back probe Aux Dig 1 White wire at terminal 42 of the ECM header connector and ground other DVOM lead</p> <p>Do you get greater than 4 volts?</p>	> 4 Volts	Repair faulty terminal at pin 42 of the wire harness Aux dig 1 White wire	Repair open circuit from starter solenoid splice to terminal 42 at the ECM header connector

## DTC 1611-5VE 1/2 Simultaneous Out of Range (SPN 1079:FMI 31)

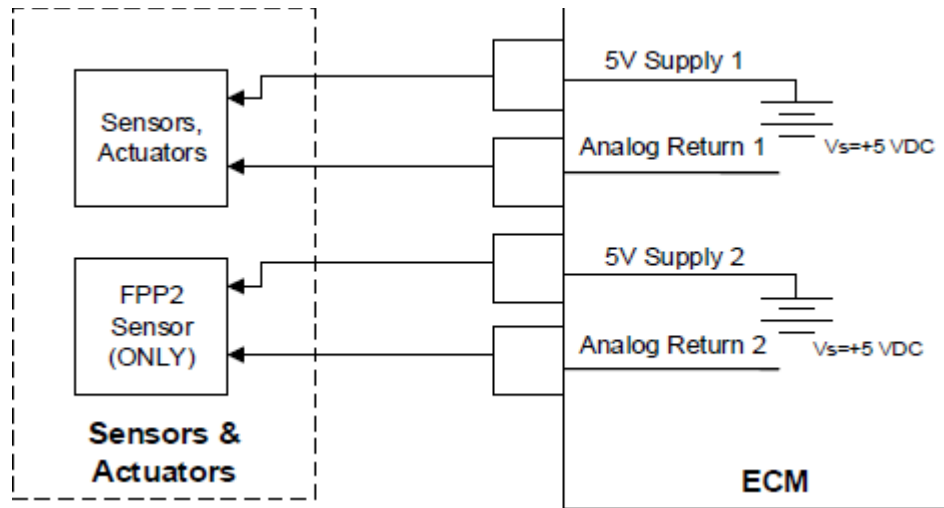

### Conditions for Setting the DTC

- Powered sensors/ actuators and FPP2
- Check Condition-Engine Running / stopped checked (user defined in calibration)
- Fault Condition-5-volt reference voltage lower than 3.00 volts
- MIL-On during active fault
- Adaptive-Disabled during active fault

### Possible Causes for Fault:

- This fault indicates that both power supply voltages are out-of-range as defined in the calibration.
- In configurations where the crank and/or camshaft position sensors are powered hall-effect sensors, the engine may stall due to loss of synchronization.

### Circuit Description

5V\_ext1 is a regulated 5 VDC output that supplies power to sensors and actuators. This power is generally supplied, but is not limited to hall-effects, potentiometers, switches, and pressure transducers. 5V\_ext2 is a low-current 5 VDC power supply intended solely for powering a second potentiometer used for electronic throttle control in configurations where high redundancy is required. High accuracy of the power supplies are required in order to ensure proper signal scaling. Both power supplies have a feedback voltage that is monitored by the ECM to determine if the output is overloaded, shorted, or otherwise out of specification.

Step	Action	Value(s)	Yes	No
1	Did you perform the On-Board (OBD) System Check?	-	Go to Step (2)	Go to OBD System Check Section
2	<ul style="list-style-type: none"> <li>• Key ON, Engine Running</li> <li>• Run Mode = "Running"</li> <li>• Verify that DTC is active</li> <li>• Is there a redundant FPP sensor connected to the ECM?</li> </ul>		Disconnect the FPP Sensor from the wire harness.	Go to Step 3
3	<ul style="list-style-type: none"> <li>• Key Off- Engine off</li> <li>• Disconnect all 5VDC powered sensor(s)/ actuator(s) from the wire harness.</li> <li>• Key On-Engine Off</li> <li>• Run Mode="Stopped"</li> <li>• Does the DST indicate DTC?</li> </ul>		Go to Step (4)	Go to step (5)
4	<ul style="list-style-type: none"> <li>• Faulty Wire harness</li> <li>• Faulty ECM</li> </ul>		Go to Step (5)	-
5	<ul style="list-style-type: none"> <li>• Faulty FPP sensor or FPP sensor wiring, replace sensor</li> <li>• Faulty sensors/actuators</li> <li>• Faulty wire harness</li> </ul>		System OK	Go to OBD System Check

## **DTC 1612-RTI 1 Loss (SPN 629:FMI 31)**

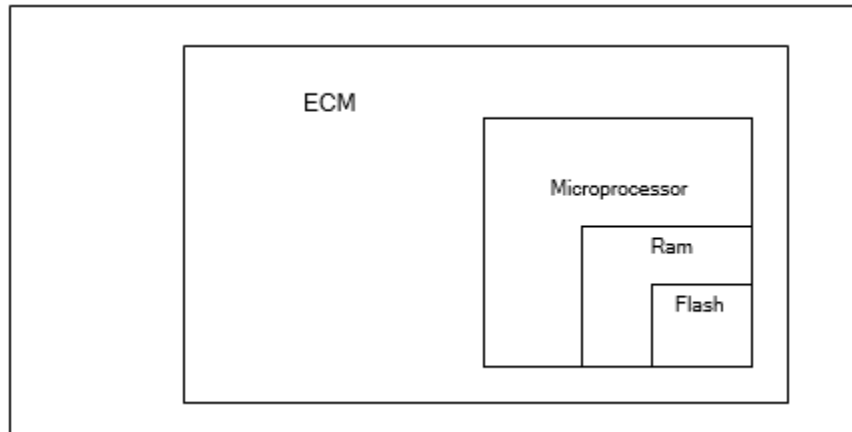

### **Conditions for Setting the DTC**

- Engine Control Module
- Check Condition-Key on
- Fault Condition-Internal microprocessor error
- MIL-ON
- Adaptive-Disabled for the remainder of the key-ON cycle

### **Circuit Description**

The ECM has several internal checks that must be satisfied each time an instruction is executed. Several different things can happen within the microprocessor that will cause this fault. The ECM will attempt to reset itself in the event this fault is set. The MIL command is on and will remain on until the code is cleared using the DST.

Step	Action	Value(s)	Yes	No
1	Did you perform the On-Board (OBD) System Check?	-	Go to Step (2)	Go to OBD System Check Section
2	<ul style="list-style-type: none"> <li>Key ON, Engine Running</li> <li>DST (Diagnostic Scan Tool) connected in System Data Mode</li> <li>Clear system fault code</li> </ul> Does DTC 1612 reset with the engine idling?		Go to Step (3)	Intermittent problem Go to Intermittent section
3	<ul style="list-style-type: none"> <li>Check ECM power and ground circuits Did the power and ground circuits check OK?</li> </ul>		Go to Step (4)	Repair the circuit as necessary. Refer to Wiring Repairs in Engine Electrical.
4	<ul style="list-style-type: none"> <li>Replace ECM</li> </ul> Is the replacement complete?		Go to Step (5)	-
5	<ul style="list-style-type: none"> <li>Remove all test equipment except the DST.</li> <li>Connect any disconnected components, fuses, etc.</li> <li>Using the DST clear DTC information from the ECM.</li> <li>Turn the ignition OFF and wait 30 seconds.</li> <li>Start the engine and operate the vehicle to full operating temperature</li> <li>Observe the MIL</li> <li>Observe engine performance and drivability</li> <li>After operating the engine within the test parameters of DTC-1612 check for any stored codes.</li> </ul> Does the engine operate normally with no stored codes?		System OK	Go to OBD System Check



## **DTC 1613-RTI 2 Loss (SPN 629:FMI 31)**

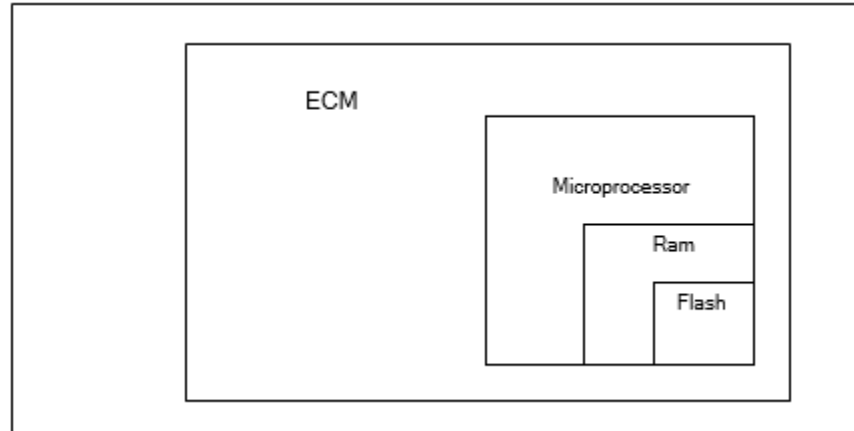

### **Conditions for Setting the DTC**

- Engine Control Module
- Check Condition-Key on
- Fault Condition-Internal microprocessor error
- MIL-ON
- Adaptive-Disabled for the remainder of the key-ON cycle

### **Circuit Description**

The ECM has several internal checks that must be satisfied each time an instruction is executed. Several different things can happen within the microprocessor that will cause this fault. The ECM will attempt to reset itself in the event this fault is set. The MIL command is on and will remain on until the code is cleared using the DST.

Step	Action	Value(s)	Yes	No
1	Did you perform the On-Board (OBD) System Check?	-	Go to Step (2)	Go to OBD System Check Section
2	<ul style="list-style-type: none"> <li>Key ON, Engine Running</li> <li>DST (Diagnostic Scan Tool) connected in System Data Mode</li> <li>Clear system fault code</li> </ul> Does DTC 1613 reset with the engine idling?		Go to Step (3)	Intermittent problem Go to Intermittent section
3	<ul style="list-style-type: none"> <li>Check ECM power and ground circuits Did the power and ground circuits check OK?</li> </ul>		Go to Step (4)	Repair the circuit as necessary. Refer to Wiring Repairs in Engine Electrical.
4	<ul style="list-style-type: none"> <li>Replace ECM</li> </ul> Is the replacement complete?		Go to Step (5)	-
5	<ul style="list-style-type: none"> <li>Remove all test equipment except the DST.</li> <li>Connect any disconnected components, fuses, etc.</li> <li>Using the DST clear DTC information from the ECM.</li> <li>Turn the ignition OFF and wait 30 seconds.</li> <li>Start the engine and operate the vehicle to full operating temperature</li> <li>Observe the MIL</li> <li>Observe engine performance and drivability</li> <li>After operating the engine within the test parameters of DTC-1613 check for any stored codes.</li> </ul> Does the engine operate normally with no stored codes?		System OK	Go to OBD System Check

## **DTC 1614-RTI 3 Loss (SPN 629:FMI 31)**

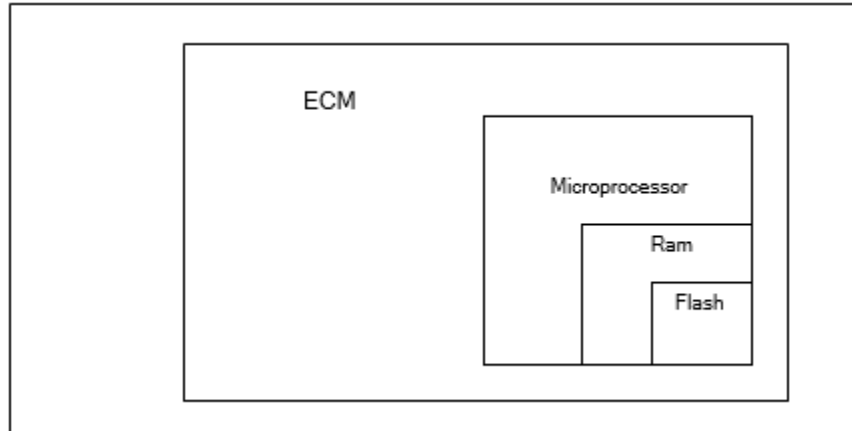

### **Conditions for Setting the DTC**

- Engine Control Module
- Check Condition-Key on
- Fault Condition-Internal microprocessor error
- MIL-ON
- Adaptive-Disabled for the remainder of the key-ON cycle

### **Circuit Description**

The ECM has several internal checks that must be satisfied each time an instruction is executed. Several different things can happen within the microprocessor that will cause this fault. The ECM will attempt to reset itself in the event this fault is set. The MIL command is on and will remain on until the code is cleared using the DST.

Step	Action	Value(s)	Yes	No
1	Did you perform the On-Board (OBD) System Check?	-	Go to Step (2)	Go to OBD System Check Section
2	<ul style="list-style-type: none"> <li>Key ON, Engine Running</li> <li>DST (Diagnostic Scan Tool) connected in System Data Mode</li> <li>Clear system fault code</li> </ul> Does DTC 1614 reset with the engine idling?		Go to Step (3)	Intermittent problem Go to Intermittent section
3	<ul style="list-style-type: none"> <li>Check ECM power and ground circuits Did the power and ground circuits check OK?</li> </ul>		Go to Step (4)	Repair the circuit as necessary. Refer to Wiring Repairs in Engine Electrical.
4	<ul style="list-style-type: none"> <li>Replace ECM</li> </ul> Is the replacement complete?		Go to Step (5)	-
5	<ul style="list-style-type: none"> <li>Remove all test equipment except the DST.</li> <li>Connect any disconnected components, fuses, etc.</li> <li>Using the DST clear DTC information from the ECM.</li> <li>Turn the ignition OFF and wait 30 seconds.</li> <li>Start the engine and operate the vehicle to full operating temperature</li> <li>Observe the MIL</li> <li>Observe engine performance and drivability</li> <li>After operating the engine within the test parameters of DTC-1614 check for any stored codes.</li> </ul> Does the engine operate normally with no stored codes?		System OK	Go to OBD System Check

## **DTC 1615-A/D Loss (SPN 629:FMI 31)**

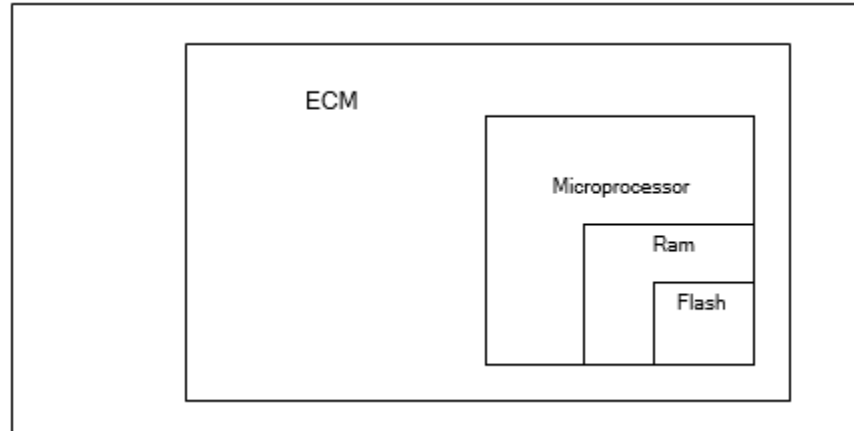

### **Conditions for Setting the DTC**

- Engine Control Module
- Check Condition-Key on
- Fault Condition-Internal microprocessor error
- MIL-ON
- Adaptive-Disabled for the remainder of the key-ON cycle

### **Circuit Description**

The ECM has several internal checks that must be satisfied each time an instruction is executed. Several different things can happen within the microprocessor that will cause this fault. The ECM will attempt to reset itself in the event this fault is set. The MIL command is on and will remain on until the code is cleared using the DST.

Step	Action	Value(s)	Yes	No
1	Did you perform the On-Board (OBD) System Check?	-	Go to Step (2)	Go to OBD System Check Section
2	<ul style="list-style-type: none"> <li>Key ON, Engine Running</li> <li>DST (Diagnostic Scan Tool) connected in System Data Mode</li> <li>Clear system fault code</li> </ul> Does DTC 1615 reset with the engine idling?		Go to Step (3)	Intermittent problem Go to Intermittent section
3	<ul style="list-style-type: none"> <li>Check ECM power and ground circuits Did the power and ground circuits check OK?</li> </ul>		Go to Step (4)	Repair the circuit as necessary. Refer to Wiring Repairs in Engine Electrical.
4	<ul style="list-style-type: none"> <li>Replace ECM</li> </ul> Is the replacement complete?		Go to Step (5)	-
5	<ul style="list-style-type: none"> <li>Remove all test equipment except the DST.</li> <li>Connect any disconnected components, fuses, etc.</li> <li>Using the DST clear DTC information from the ECM.</li> <li>Turn the ignition OFF and wait 30 seconds.</li> <li>Start the engine and operate the vehicle to full operating temperature</li> <li>Observe the MIL</li> <li>Observe engine performance and drivability</li> <li>After operating the engine within the test parameters of DTC-1615 check for any stored codes.</li> </ul> Does the engine operate normally with no stored codes?		System OK	Go to OBD System Check

## **DTC 1616-Invalid Interrupt (SPN 629:FMI 31)**

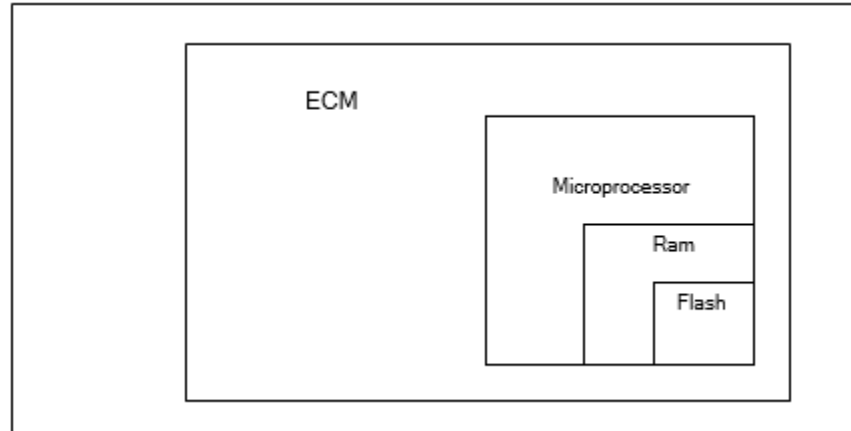

### **Conditions for Setting the DTC**

- Engine Control Module
- Check Condition-Key on
- Fault Condition-Internal microprocessor error
- MIL-ON
- Adaptive-Disabled for the remainder of the key-ON cycle

### **Circuit Description**

The ECM has several internal checks that must be satisfied each time an instruction is executed. Several different things can happen within the microprocessor that will cause this fault. The ECM will attempt to reset itself in the event this fault is set. The MIL command is on and will remain on until the code is cleared using the DST.

Step	Action	Value(s)	Yes	No
1	Did you perform the On-Board (OBD) System Check?	-	Go to Step (2)	Go to OBD System Check Section
2	<ul style="list-style-type: none"> <li>• Key ON, Engine Running</li> <li>• DST (Diagnostic Scan Tool) connected in System Data Mode</li> <li>• Clear system fault code</li> </ul> Does DTC 1616 reset with the engine idling?		Go to Step (3)	Intermittent problem Go to Intermittent section
3	<ul style="list-style-type: none"> <li>• Check ECM power and ground circuits Did the power and ground circuits check OK?</li> </ul>		Go to Step (4)	Repair the circuit as necessary. Refer to Wiring Repairs in Engine Electrical.
4	<ul style="list-style-type: none"> <li>• Replace ECM</li> </ul> Is the replacement complete?		Go to Step (5)	-
5	<ul style="list-style-type: none"> <li>• Remove all test equipment except the DST.</li> <li>• Connect any disconnected components, fuses, etc.</li> <li>• Using the DST clear DTC information from the ECM.</li> <li>• Turn the ignition OFF and wait 30 seconds.</li> <li>• Start the engine and operate the vehicle to full operating temperature</li> <li>• Observe the MIL</li> <li>• Observe engine performance and drivability</li> <li>• After operating the engine within the test parameters of DTC-1616 check for any stored codes.</li> </ul> Does the engine operate normally with no stored codes?		System OK	Go to OBD System Check



## DTC 1625- J1939 Shutdown Request (SPN 1100:FMI 31)

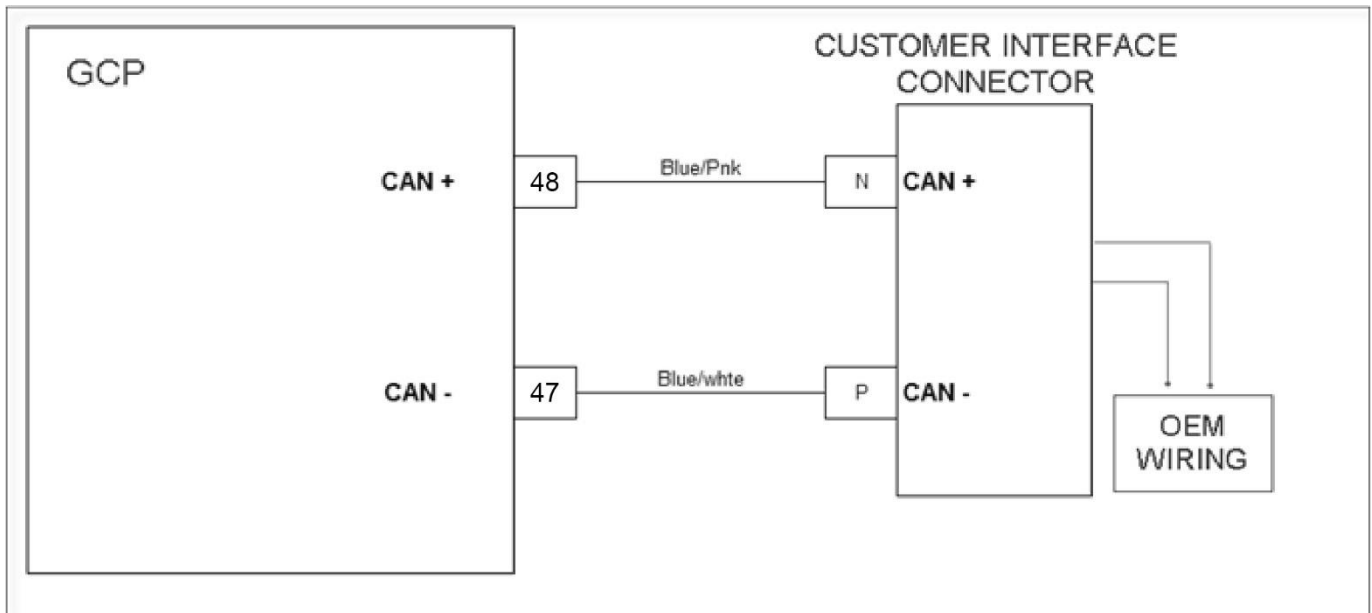

### Conditions for Setting the DTC

- Fault signal from OEM device
- Check Condition-Engine running
- MIL-ON

### Circuit description

The OEM can connect to the J1939 circuit (CAN circuit) at the customer interface connector 2. The terminals are N and P and continue through the engine wire harness into the ECM header connector. The terminals at the ECM for J1939 are pins 14 and 15. This DTC will set if the OEM device hooked into terminals N and P at the customer interface connector commands the engine to shut down.

## DTC 1626- CAN Tx Failure (SPN 639:FMI 12)

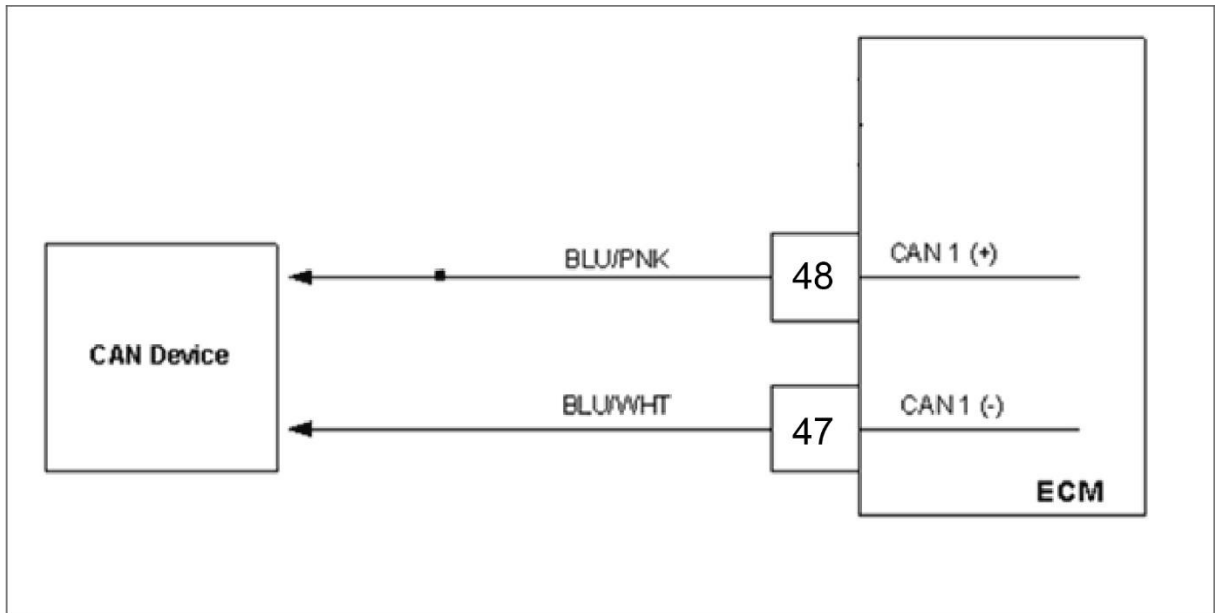

### Conditions for Setting the DTC

- CAN Tx
- Check Condition-Engine running
- Fault Condition-CAN Tx error 120 packets lost within 1 second
- MIL-ON

### Circuit description

The CAN bus (controller area network) is used by the ECM to communicate with other digital devices used throughout the fuel system. Information is sent over the CAN bus in digital information “packets” that contain information for various control functions. This fault will set if the ECM detects 120 packets lost within a one second time period. The MIL command is ON.

Step	Action	Value(s)	Yes	No
1	Did you perform the On-Board (OBD) System Check?	-	Go to Step (2)	Go to OBD System Check Section
2	<ul style="list-style-type: none"> <li>Key ON, Engine Running</li> <li>DST (Diagnostic Scan Tool) connected in System Data Mode</li> <li>Clear system fault code</li> </ul> Does DTC1626 reset with the engine idling?		Go to Step (3)	Intermittent problem Go to Intermittent section
3	<ul style="list-style-type: none"> <li>Check that the ECM power connection C019 is clean, tight and in the proper location.</li> <li>Check that the ECM ground connection C010 is clean, tight and in the proper location.</li> </ul> Are the power and ground circuits OK?		Go to Step (4)	Repair the circuit as necessary. Refer to Wiring Repairs in Engine Electrical.
4	<ul style="list-style-type: none"> <li>Using a DVOM check for continuity between ECM pins 47 and 48</li> </ul> Do you have continuity between them?		Repair the shorted circuit as necessary. Refer to Wiring Repairs in Engine Electrical.	Go to Step (5)
5	<ul style="list-style-type: none"> <li>Using a DVOM check for continuity to engine ground on pins 69 and 81</li> </ul> Do have continuity to engine ground?		Repair the shorted to ground circuit as necessary. Refer to Wiring Repairs in Engine Electrical.	Go to Step (6)
6	<ul style="list-style-type: none"> <li>Using a DVOM check for continuity to battery positive on pins 69 and 81</li> </ul> Do have continuity them?		Repair the shorted to ground circuit as necessary. Refer to Wiring Repairs in Engine Electrical.	Go to Step (7)
7	<ul style="list-style-type: none"> <li>Replace the ECM</li> </ul> Is the replacement complete?		Go to Step (8)	-

Step	Action	Value(s)	Yes	No
8	<ul style="list-style-type: none"> <li>• Remove all test equipment except the DST.</li> <li>• Connect any disconnected components, fuses, etc.</li> <li>• Using the DST clear DTC information from the ECM.</li> <li>• Turn the ignition OFF and wait 30 seconds.</li> <li>• Start the engine and operate the vehicle to full operating temperature</li> <li>• Observe the MIL</li> <li>• Observe engine performance and drivability</li> <li>• After operating the engine within the test parameters of DTC-1626 check for any stored codes.</li> </ul> <p>Does the engine operate normally with no stored codes?</p>		System OK	Go to OBD System Check

## DTC 1627-CAN Rx Failure (SPN 639:FMI 12)

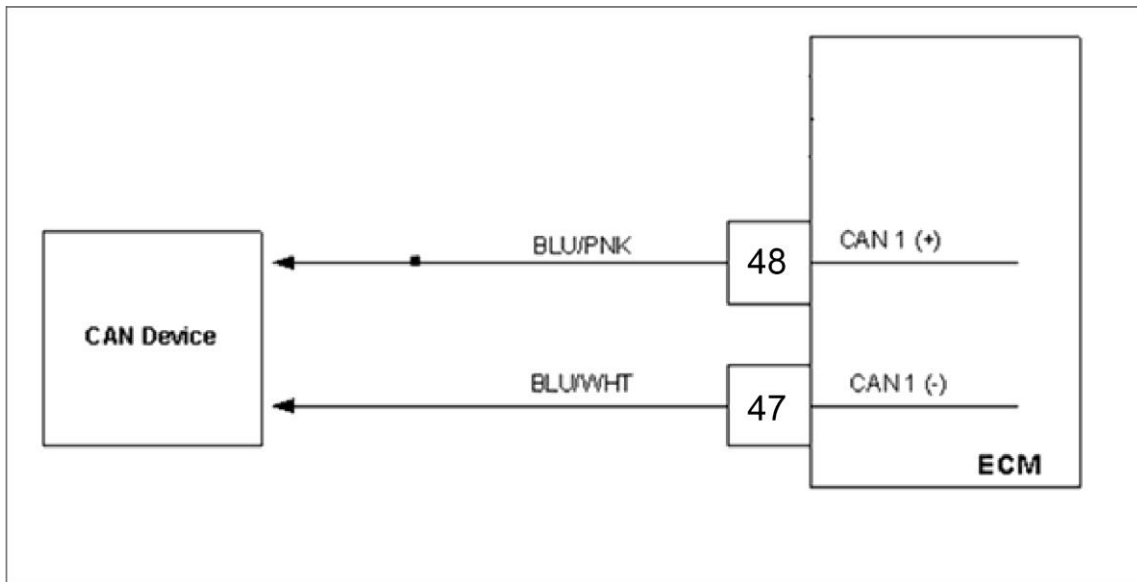

### Conditions for Setting the DTC

- CAN Rx
- Check Condition-Engine running
- Fault Condition-CAN Rx error 120 packets lost within 1 second
- MIL-ON

### Circuit description

The CAN bus (controller area network) is used by the ECM to communicate with other digital devices used throughout the fuel system. Information is sent over the CAN bus in digital information “packets” that contain information for various control functions. This fault will set if the ECM detects 120 packets lost within a one second time period. The MIL command is ON.

Step	Action	Value(s)	Yes	No
1	Did you perform the On-Board (OBD) System Check?	-	Go to Step (2)	Go to OBD System Check Section
2	<ul style="list-style-type: none"> <li>Key ON, Engine Running</li> <li>DST (Diagnostic Scan Tool) connected in System Data Mode</li> <li>Clear system fault code</li> </ul> Does DTC1627 reset with the engine idling?		Go to Step (3)	Intermittent problem Go to Intermittent section
3	<ul style="list-style-type: none"> <li>Check that the ECM power connection C019 is clean, tight and in the proper location.</li> <li>Check that the ECM ground connection C010 is clean, tight and in the proper location.</li> </ul> Are the power and ground circuits, OK?		Go to Step (4)	Repair the circuit as necessary. Refer to Wiring Re- pairs in Engine Electrical.
4	<ul style="list-style-type: none"> <li>Using a DVOM check for continuity between ECM pins 47 and 48</li> </ul> Do you have continuity between them?		Repair the shorted circuit as necessary. Refer to Wiring Repairs in Engine Electrical.	Go to Step (5)
5	<ul style="list-style-type: none"> <li>Using a DVOM check for continuity to engine ground on pin 48.</li> </ul> Do have continuity to engine ground?		Repair the shorted to ground circuit as necessary. Refer to Wiring Repairs in Engine Electrical.	Go to Step (6)
6	<ul style="list-style-type: none"> <li>Using a DVOM check for continuity to battery positive on pin 48.</li> </ul> Do have continuity between them?		Repair the shorted to ground circuit as necessary. Refer to Wiring Repairs in Engine Electrical.	Go to Step (7)
7	<ul style="list-style-type: none"> <li>Replace the ECM</li> </ul> Is the replacement complete?		Go to Step (8)	-

Step	Action	Value(s)	Yes	No
8	<ul style="list-style-type: none"> <li>• Remove all test equipment except the DST.</li> <li>• Connect any disconnected components, fuses, etc.</li> <li>• Using the DST clear DTC information from the ECM.</li> <li>• Turn the ignition OFF and wait 30 seconds.</li> <li>• Start the engine and operate the vehicle to full operating temperature</li> <li>• Observe the MIL</li> <li>• Observe engine performance and drivability</li> <li>• After operating the engine within the test parameters of DTC-1627 check for any stored codes.</li> </ul> <p>Does the engine operate normally with no stored codes?</p>		System OK	Go to OBD System Check

## DTC 1628-CAN Address Conflict (SPN 639:FMI 13)

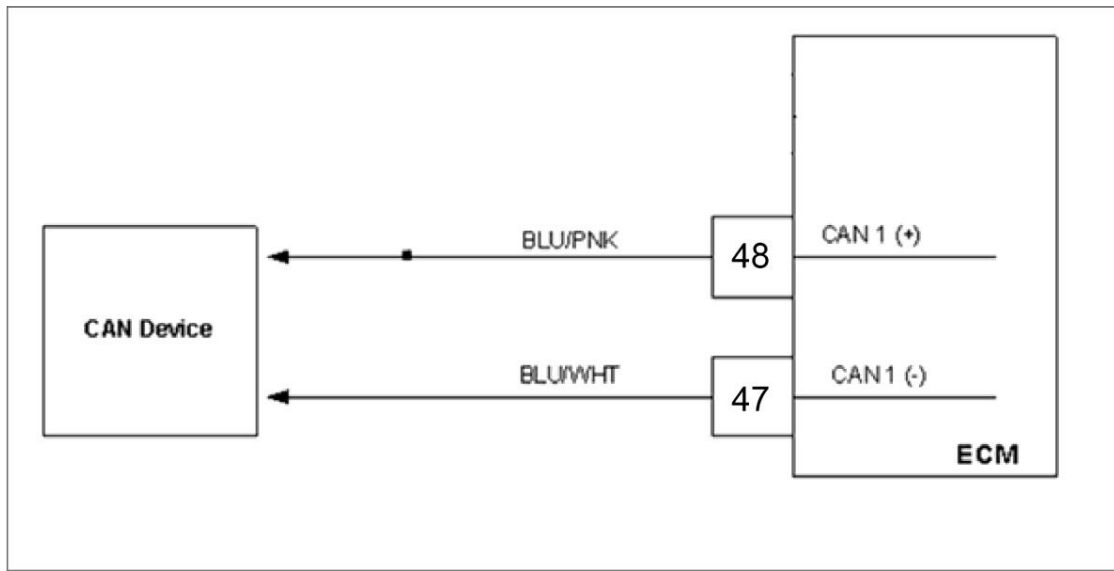

### Conditions for Setting the DTC

- CAN Rx
- Check Condition-Engine running
- Fault Condition-5 or more address conflict errors
- MIL-ON

### Circuit description

The CAN bus (controller area network) is used by the ECM to communicate with other digital devices used throughout the fuel system. Information is sent over the CAN bus in digital information “packets” that contain information for various control functions. Individual devices are assigned network addresses. This fault will set if the ECM detects an address conflict, such as two devices with the same address. This is usually not due to an infield failure and may be the results of “add on” CAN devices.



Step	Action	Value(s)	Yes	No
1	Did you perform the On-Board (OBD) System Check?	-	Go to Step (2)	Go to OBD System Check Section
2	<ul style="list-style-type: none"> <li>Key ON, Engine Running</li> <li>DST (Diagnostic Scan Tool) connected in System Data Mode</li> <li>Clear system fault code</li> </ul> Does DTC1628 reset with the engine idling?		Go to Step (3)	Intermittent problem Go to Intermittent section
3	<ul style="list-style-type: none"> <li>Key OFF</li> <li>Disconnect one CAN device</li> <li>Clear DTC 1628</li> <li>Key ON (start engine if possible if not continue cranking for at least 3 seconds)</li> <li>Wait 5 seconds Does DTC 1628 re-set?</li> </ul>		Repeat step 3 until all CAN devices have been disconnected one at a time	Contact the CAN device manufacturer for additional CAN address information Go to Step (4)
4	Has the CAN device been replaced, or address conflict resolved?		Go to Step (5)	-
5	<ul style="list-style-type: none"> <li>Remove all test equipment except the DST.</li> <li>Connect any disconnected components, fuses, etc.</li> <li>Using the DST clear DTC information from the ECM.</li> <li>Turn the ignition OFF and wait 30 seconds.</li> <li>Start the engine and operate the vehicle to full operating temperature</li> <li>Observe the MIL</li> <li>Observe engine performance and drivability</li> <li>After operating the engine within the test parameters of DTC-1628 check for any stored codes.</li> </ul> Does the engine operate normally with no stored codes?		System OK	Go to OBD System Check

## DTC 1644-MIL Control Ground Short (SPN 1213:FMI 4)

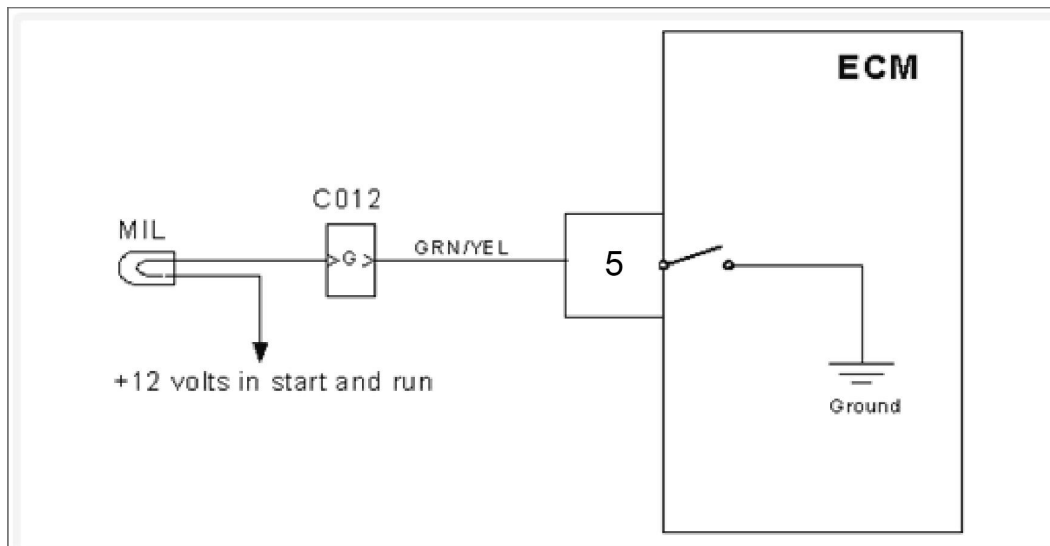

### Conditions for setting the DTC

- MIL
- Check Condition-Key ON engine OFF
- Fault Condition-ECM MIL output shorted to ground
- MIL Command-ON

### Circuit Description

The Spectrum Fuel system is equipped with OBD (On-Board Diagnostics). The system has a dash mounted MIL (Malfunction Indicator Lamp). The MIL serves as notification of an emissions related problem. The MIL also has the ability to flash DTC codes in what is referred to as the blink code mode. It will display DTCs that have been stored due to a possible system malfunction. The following DTC charts in this manual will instruct the technician to perform the OBD system check. This simply means to verify the operation of the MIL. The lamp should illuminate when the key is in the ON position, and the engine is not running. This feature verifies that the lamp is in proper working order. If the lamp does not illuminate with the vehicle key ON and engine OFF, repair it as soon as possible. Once the engine is in start or run mode, the lamp should go off. If the lamp stays on while the engine is in the start or run mode, a current diagnostic trouble code may be set or a problem may exist with the MIL electrical wiring. The electrical schematic above shows the MIL power source supplied to the lamp. The ECM completes the circuit to ground to turn the lamp ON. This fault will set if the ECM MIL control is shorted to ground.

Step	Action	Value(s)	Yes	No
1	Did you perform the On-Board (OBD) System Check?	-	Go to Step (2)	Go to OBD System Check Section
2	<ul style="list-style-type: none"> <li>Key ON, Engine Running</li> <li>DST (Diagnostic Scan Tool) connected in System Data Mode</li> <li>Clear system fault code</li> <li>Key OFF</li> <li>Key ON</li> </ul> Does DTC 1644 reset?		Go to Step (3)	Intermittent problem Go to Intermittent section
3	<ul style="list-style-type: none"> <li>Key OFF</li> <li>Disconnect the ECM wire harness connector C001</li> <li>Using a DVOM check for continuity between ECM connector pin 5 and engine ground</li> </ul> Do you have continuity?		Go to Step (4)	Intermittent problem Go to Intermittent section
4	<ul style="list-style-type: none"> <li>Disconnect vehicle interface connector C012</li> <li>Using a DVOM check for continuity between ECM connector pin 5 and engine ground</li> </ul> Do you have continuity?		Repair the shorted to ground circuit between the ECM connector and engine ground. Then go to step (6)	Repair the MIL control wire short to ground between the vehicle interface connector and vehicle chassis. Then go to step (6)
5	<ul style="list-style-type: none"> <li>Replace the ECM</li> </ul> Is the replacement complete?		Go to Step (7)	-
6	<ul style="list-style-type: none"> <li>Remove all test equipment except the DST.</li> <li>Connect any disconnected components, fuses, etc.</li> <li>Using the DST clear DTC information from the ECM.</li> <li>Turn the ignition OFF and wait 30 seconds.</li> <li>Start the engine and operate the vehicle to full operating temperature</li> <li>Observe the MIL</li> <li>Observe engine performance and drivability</li> <li>After operating the engine within the test parameters of DTC-1644 check for any stored codes.</li> </ul> Does the engine operate normally with no stored codes?		System OK	Go to Step (5)

Step	Action	Value(s)	Yes	No
7	<ul style="list-style-type: none"> <li>• Remove all test equipment except the DST.</li> <li>• Connect any disconnected components, fuses, etc.</li> <li>• Using the DST clear DTC information from the ECM.</li> <li>• Turn the ignition OFF and wait 30 seconds.</li> <li>• Start the engine and operate the vehicle to full operating temperature</li> <li>• Observe the MIL</li> <li>• Observe engine performance and drivability</li> <li>• After operating the engine within the test parameters of DTC-1644 check for any stored codes.</li> </ul> <p>Does the engine operate normally with no stored codes?</p>		System OK	Go to OBD System check

## DTC 1645-MIL Control Ground Short To Power (SPN 1213:FMI 3)

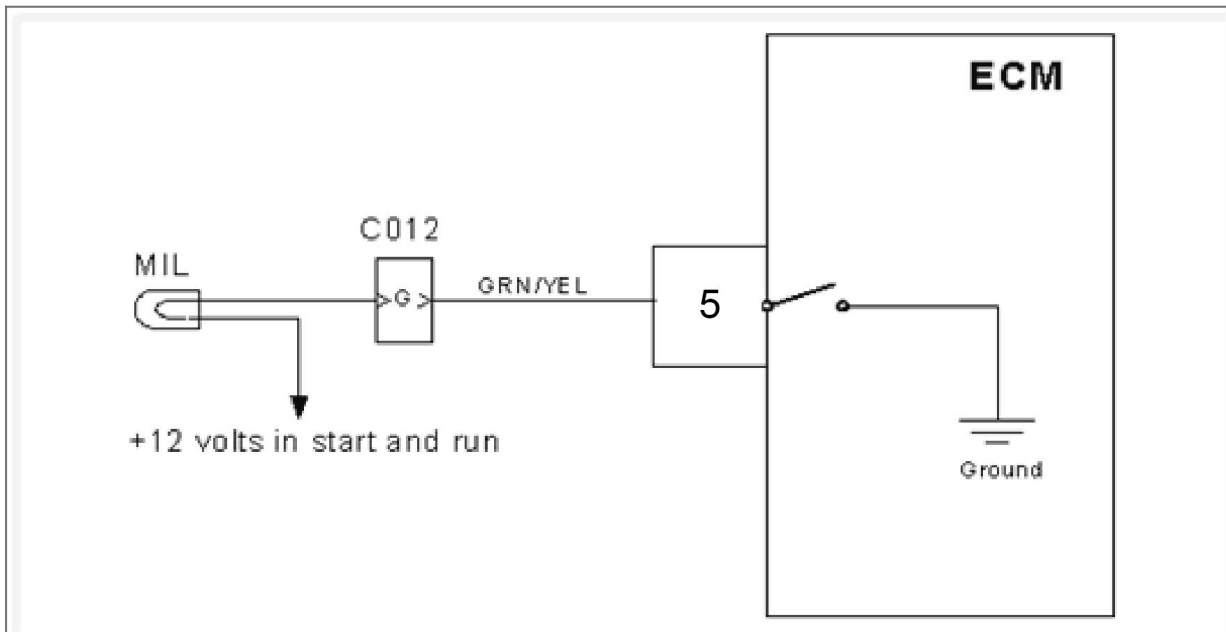

### Conditions for setting the DTC

- MIL check
- Check Condition-Key ON engine OFF
- Fault Condition-ECM MIL output shorted to voltage
- MIL Command-ON

### Circuit Description

The Spectrum Fuel system is equipped with OBD (On-Board Diagnostics). The system has a dash mounted MIL (Malfunction Indicator Lamp). The MIL serves as notification of an emissions related problem. The MIL also has the ability to flash DTC codes in what is referred to as the blink code mode. It will display DTCs that have been stored due to a possible system malfunction. The following DTC charts in this manual will instruct the technician to perform the OBD system check. This simply means to verify the operation of the MIL. The lamp should illuminate when the key is in the ON position, and the engine is not running. This feature verifies that the lamp is in proper working order. If the lamp does not illuminate with the vehicle key ON and engine OFF, repair it as soon as possible. Once the engine is in start or run mode, the lamp should go off. If the lamp stays on while the engine is in the start or run mode, a current diagnostic trouble code may be set or a problem may exist with the MIL electrical wiring. The electrical schematic above shows the MIL power source supplied to the lamp. The ECM completes the circuit to ground to turn the lamp ON. This fault will set if the ECM MIL control is shorted to voltage.

Step	Action	Value(s)	Yes	No
1	Did you perform the On-Board (OBD) System Check?	-	Go to Step (2)	Go to OBD System Check Section
2	<ul style="list-style-type: none"> <li>• Key ON, Engine Running</li> <li>• DST (Diagnostic Scan Tool) connected in System Data Mode</li> <li>• Clear system fault code</li> <li>• Key OFF</li> <li>• Key ON</li> </ul> Does DTC 1644 reset?		Go to Step (3)	Intermittent problem Go to Intermittent section
3	<ul style="list-style-type: none"> <li>• Key OFF</li> <li>• Disconnect the ECM wire harness connector C001</li> <li>• Using a DVOM check for voltage between ECM connector pin 5 and engine ground</li> <li>• Key ON</li> </ul> Do you have voltage?		Go to Step (4)	Intermittent problem Go to Intermittent section
4	<ul style="list-style-type: none"> <li>• Disconnect vehicle interface connector C012</li> <li>• Using a DVOM check for voltage between ECM connector pin 5 and engine ground</li> </ul> Do you have voltage?		Repair the shorted to voltage circuit between the ECM connector and engine ground. Then go to step (6)	Repair the MIL control wire short to voltage between the vehicle interface connector and vehicle chassis. Then go to step (6)
5	<ul style="list-style-type: none"> <li>• Replace the ECM</li> </ul> Is the replacement complete?		Go to Step (7)	-
6	<ul style="list-style-type: none"> <li>• Remove all test equipment except the DST.</li> <li>• Connect any disconnected components, fuses, etc.</li> <li>• Using the DST clear DTC information from the ECM.</li> <li>• Turn the ignition OFF and wait 30 seconds.</li> <li>• Start the engine and operate the vehicle to full operating temperature</li> <li>• Observe the MIL</li> <li>• Observe engine performance and drivability</li> <li>• After operating the engine within the test parameters of DTC-1645 check for any stored codes.</li> </ul> Does the engine operate normally with no stored codes?		System OK	Go to Step (5)

Step	Action	Value(s)	Yes	No
7	<ul style="list-style-type: none"> <li>• Remove all test equipment except the DST.</li> <li>• Connect any disconnected components, fuses, etc.</li> <li>• Using the DST clear DTC information from the ECM.</li> <li>• Turn the ignition OFF and wait 30 seconds.</li> <li>• Start the engine and operate the vehicle to full operating temperature</li> <li>• Observe the MIL</li> <li>• Observe engine performance and drivability</li> <li>• After operating the engine within the test parameters of DTC-1645 check for any stored codes.</li> </ul> <p>Does the engine operate normally with no stored codes?</p>		System OK	Go to OBD System check

## DTC 1673-Calibration Configuration Error (SPN 1634:FMI 13)

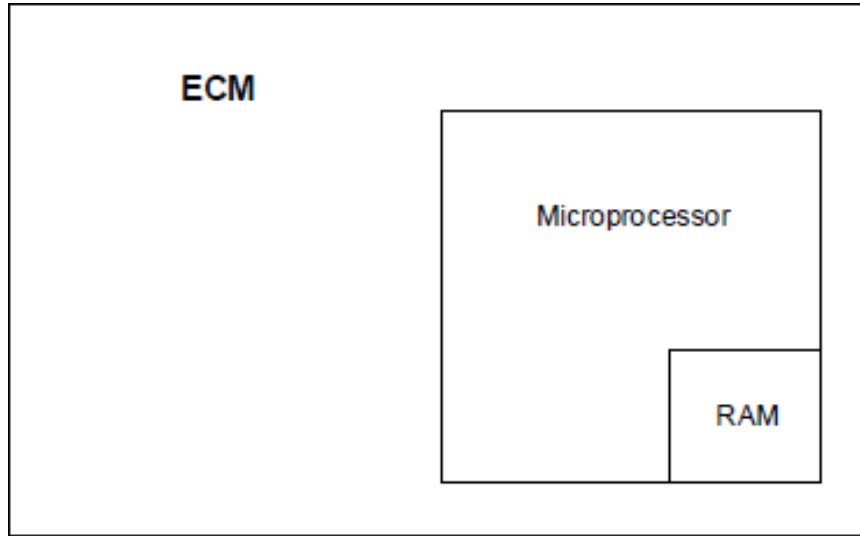

### **Conditions for setting the DTC**

- Calibration configuration error
- Check Condition-Engine Running/ Stopped checked
- Fault Condition-Specific calibration variable checks do not return results.

### **Circuit Description**

If the ECM is reprogrammed with an un-authorized calibration this fault will be set.



## DTC 1674-Hardware ID Failure (SPN 1634:FMI 2)

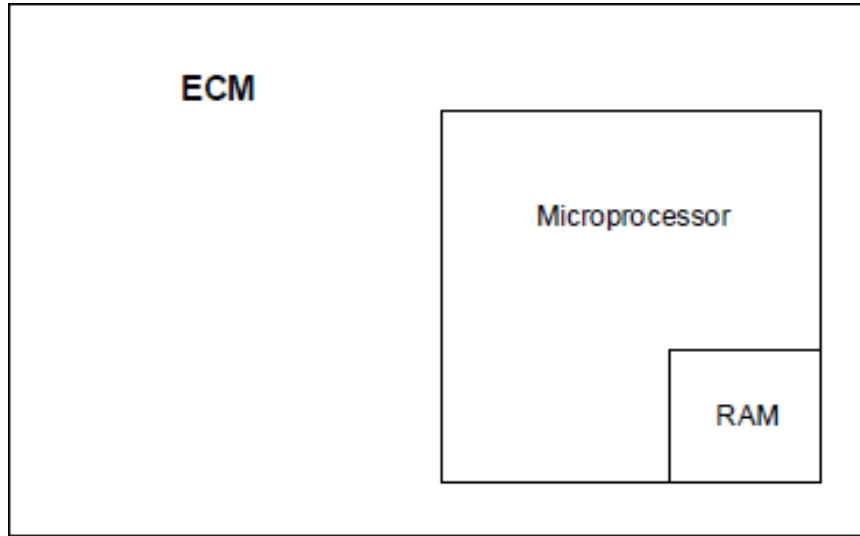

### Conditions for setting the DTC

- Engine Control Module - Hardware ID Failure
- Check Condition-Engine Running/ Stopped checked
- Fault Condition-MOT file is too old for ECM hardware revision level

### Circuit Description

The ECM checks the MOT file against hardware ID tags that indicate the current ECM hardware revisions level. If this fault sets, the ECM will reset itself and log the code.

## DTC 2111-Unable To Reach Lower TPS (SPN 51:FMI 7)

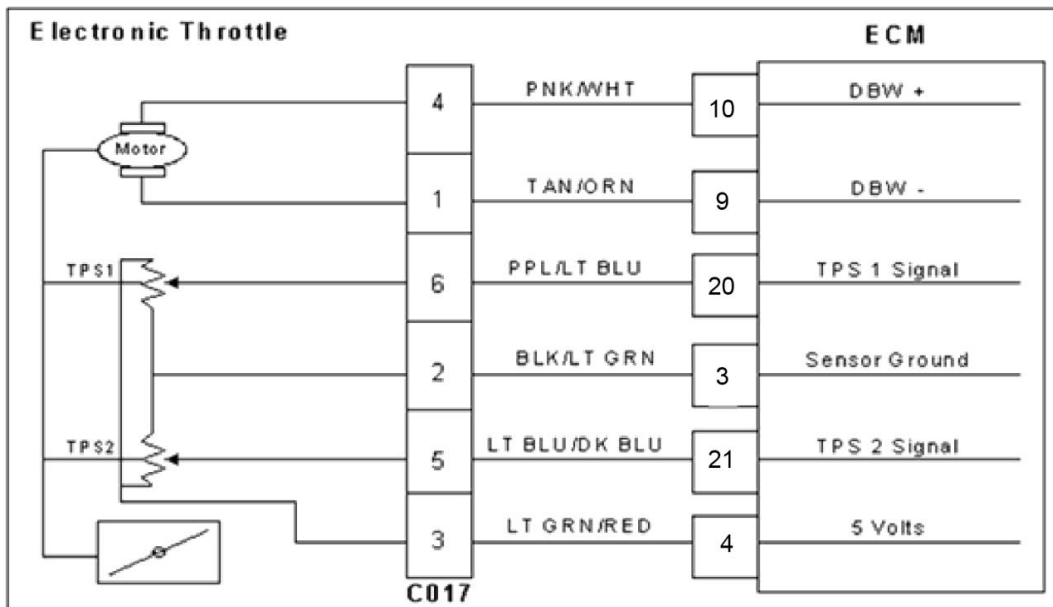

### Conditions for Setting the DTC

- Throttle Position Sensor
- Check Condition-Cranking or Running
- Fault Condition-Actual throttle position is 20% greater than the throttle command
- MIL-ON during active fault
- Engine shutdown

### Circuit Description

Dual throttle Position Sensors are used within the throttle that use variable resistors to determine signal voltage based on throttle plate position. TPS 1 will read low voltage when closed and TPS 2 will read high voltage when closed. The TPS 1 and TPS 2 percentages are calculated from these voltages. Although the voltages are different, the calculated values for the throttle position percentages should be very close to the same. The TPS values are used by the ECM to determine if the throttle is opening as commanded. This fault will set if the actual throttle position is 20% greater than the throttle command. During this active fault the MIL command is ON and the engine will shut down.

Step	Action	Value(s)	Yes	No
1	Did you perform the On-Board (OBD) System Check?	-	Go to Step (2)	Go to OBD System Check Section
2	<ul style="list-style-type: none"> <li>Key ON, Engine OFF</li> <li>DST (Diagnostic Scan Tool) connected inDBW (Drive By Wire) test mode</li> <li>Depress foot pedal until the throttle command is between 63%-68%</li> </ul> Is the TPS 1 voltage greater than 2.0 volts?		Go to Step (3)	Intermittent problem Go to Intermittent section
3	<ul style="list-style-type: none"> <li>Key OFF</li> <li>Disconnect electronic throttle connector C017</li> <li>Probe TPS 1 signal pin 6 with a test light connected to battery voltage</li> <li>Key ON</li> </ul> Does DST display TPS 1 voltage less than 0.2volts?		Go to Step (6)	Go to Step (4)
4	<ul style="list-style-type: none"> <li>Key OFF</li> <li>Disconnect ECM wire harness connector C001</li> <li>Key ON</li> <li>Using a DVOM check for voltage between throttle connector TPS 1signal pin 6 and engine ground</li> </ul> Do you have voltage?		Repair the circuit as necessary. Refer to Wiring Repairs in Engine Electrical.	Go to Step (5)
5	<ul style="list-style-type: none"> <li>Replace ECM</li> </ul> Is the replacement complete?		Go to Step (13)	-
6	<ul style="list-style-type: none"> <li>Probe sensor ground circuit at ECM connector C001 with a test light connected to battery voltage</li> </ul> Does the test light come on?		Go to Step (9)	Go to Step (7)
7	<ul style="list-style-type: none"> <li>Key OFF</li> <li>Disconnect ECM wire harness connector C001</li> <li>Using a DVOM check for continuity between throttle connector signal ground pin 2 and ECM signal ground circuit pin 3</li> </ul> Do you have continuity between them?		Go to Step (8)	Repair the circuit as necessary. Refer to Wiring Repairs in Engine Electrical.
8	<ul style="list-style-type: none"> <li>Replace ECM</li> </ul> Is the replacement complete?		Go to Step (13)	-
9	<ul style="list-style-type: none"> <li>Check throttle for foreign object in bore</li> </ul> Did you find a foreign object in the bore?		Go to Step (10)	Go to Step (11)
10	<ul style="list-style-type: none"> <li>Remove foreign objects</li> </ul> Is the removal complete?		Go to Step (13)	-

Step	Action	Value(s)	Yes	No
11	<ul style="list-style-type: none"> <li>Inspect the throttle wire harness connector terminals for damage, corrosion or contamination</li> </ul> Did you find the problem?		Repair the circuit as necessary. Refer to Wiring Repairs in Engine Electrical.	Go to Step (12)
12	<ul style="list-style-type: none"> <li>Replace throttle</li> </ul> Is the replacement complete?		Go to Step (13)	-
13	<ul style="list-style-type: none"> <li>Remove all test equipment except the DST.</li> <li>Connect any disconnected components, fuses, etc.</li> <li>Using the DST clear DTC information from the ECM.</li> <li>Turn the ignition OFF and wait 30 seconds.</li> <li>Start the engine and operate the vehicle to full operating temperature</li> <li>Observe the MIL</li> <li>Observe engine performance and drivability</li> <li>After operating the engine within the test parameters of DTC-2111 check for any stored codes.</li> </ul> Does the engine operate normally with no stored codes?		System OK	Go to OBD System Check

## DTC 2112-Unable To Reach Higher TPS (SPN 51:FMI 7)

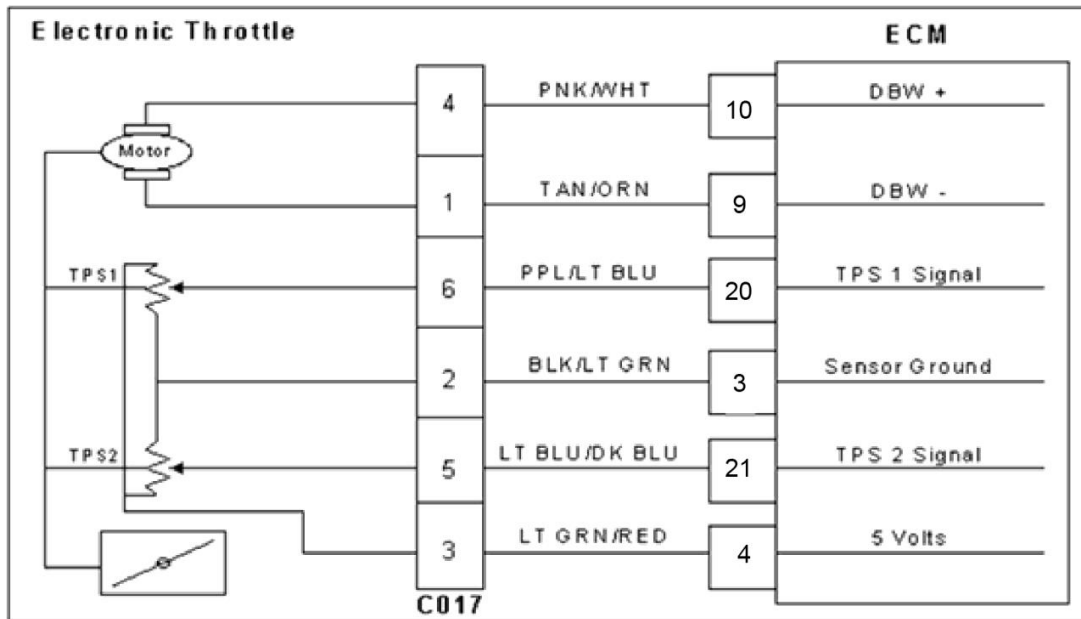

### Conditions for Setting the DTC

- Throttle Position Sensor
- Check Condition-Cranking or Running
- Fault Condition-Actual throttle position is 20% less than the throttle command
- MIL-ON during active fault
- Engine shutdown

### Circuit Description

Dual throttle Position Sensors are used within the throttle that use variable resistors to determine signal voltage based on throttle plate position. TPS 1 will read low voltage when closed and TPS 2 will read high voltage when closed. The TPS 1 and TPS 2 percentages are calculated from these voltages. Although the voltages are different, the calculated values for the throttle position percentages should be very close to the same. The TPS values are used by the ECM to determine if the throttle is opening as commanded. This fault will set if the actual throttle position is 20% less than the throttle command. The MIL command is ON and the engine will shut down.

Step	Action	Value(s)	Yes	No
1	Did you perform the On-Board (OBD) System Check?	-	Go to Step (2)	Go to OBD System Check Section
2	<ul style="list-style-type: none"> <li>Key ON, Engine OFF</li> <li>DST (Diagnostic Scan Tool) connected inDBW (Drive By Wire) test mode</li> <li>Depress foot pedal until the throttle command is 63%-68%</li> </ul> Is the TPS voltage less than 2.0 volts?		Go to Step (3)	Intermittent problem Go to Intermittent section
3	<ul style="list-style-type: none"> <li>Key OFF</li> <li>Disconnect electronic throttle connector C017</li> <li>Probe TPS 1 signal circuit pin 6 with test light connected to battery voltage</li> <li>Key ON</li> </ul> Is TPS voltage 4.0 volts or greater?		Go to Step (4)	Go to Step (8)
4	<ul style="list-style-type: none"> <li>Check throttle bore for foreign object</li> </ul> Did you find a problem?		Go to Step (5)	Go to Step (6)
5	<ul style="list-style-type: none"> <li>Remove the foreign object</li> </ul> Has the object been removed?		Go to Step (11)	-
6	<ul style="list-style-type: none"> <li>Check the electronic throttle connector terminals for damage corrosion or contamination</li> </ul> Did you find a problem?		Repair the circuit as necessary. Refer to Wiring Repairs in Engine Electrical.	Go to Step (7)
7	<ul style="list-style-type: none"> <li>Replace throttle</li> </ul> Is the replacement complete?		Go to Step (11)	-
8	<ul style="list-style-type: none"> <li>Key OFF</li> <li>Disconnect ECM wire harness connector C001</li> <li>Using a DVOM check for continuity between throttle connector TPS 1 signal pin 6 and ECM TPS 1 signal pin 20</li> </ul> Do you have continuity between them?		Go to Step (9)	Repair the circuit as necessary. Refer to Wiring Repairs in Engine Electrical.
9	<ul style="list-style-type: none"> <li>Using a DVOM check for continuity between throttle connector TPS 1 signal pin 6 and engine ground</li> </ul> Do you have continuity between them?		Repair the shorted to ground circuit as necessary. Refer to Wiring Repairs in Engine Electrical.	Go to Step (10)
10	<ul style="list-style-type: none"> <li>Replace ECM</li> </ul> Is the replacement complete?		Go to Step (11)	-

Step	Action	Value(s)	Yes	No
11	<ul style="list-style-type: none"> <li>• Remove all test equipment except the DST.</li> <li>• Connect any disconnected components, fuses, etc.</li> <li>• Using the DST clear DTC information from the ECM.</li> <li>• Turn the ignition OFF and wait 30 seconds.</li> <li>• Start the engine and operate the vehicle to full operating temperature</li> <li>• Observe the MIL</li> <li>• Observe engine performance and drivability</li> <li>• After operating the engine within the test parameters of DTC-2112 check for any stored codes.</li> </ul> <p>Does the engine operate normally with no stored codes?</p>		System OK	Go to OBD System Check

## DTC 2121-FPP 1 Lower Than FPP 2 (SPN 91:FMI 18)

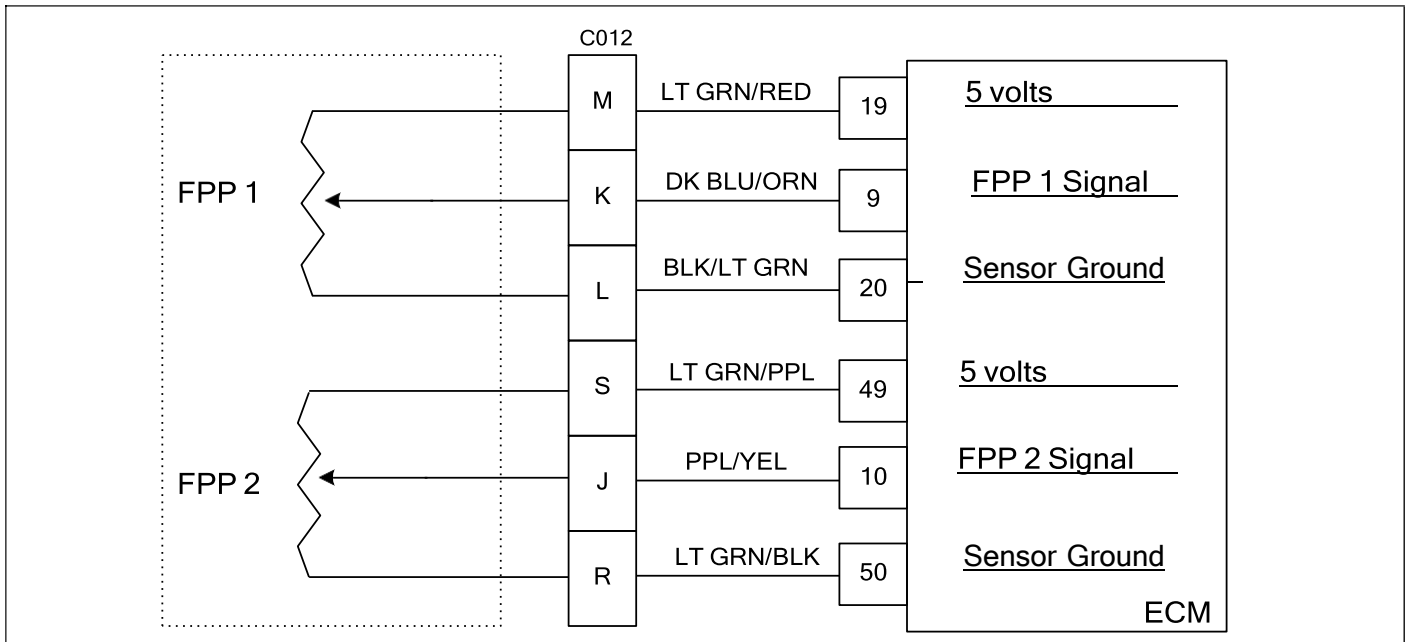

### Conditions for Setting the DTC

- Foot pedal position sensor 1 and 2
- Check Condition-Key ON
- Fault Condition-FPP1 sensor higher than FPP 2
- MIL-ON
- Force idle
- Low rev limit

### Circuit Description

The foot pedal position sensor uses variable resistors to determine signal voltage based on foot pedal position. Although the voltage outputs are different, the calculated throttle position values should be very close to the same. This fault will set if FPP 1 is 20% or greater than the FPP 2. The MIL command is ON. Forced idle and low rev limit are in effect during this fault limiting full power output.

### Diagnostic Aid

FPP sensors are OEM specific and vary in configuration. The exact wire color and pin numbers for the FPP must be verified in the OEM chassis wiring schematic. The FPP sensor used in this system provides two sensors in one packaged assembly. FPP1 and FPP 2 are not serviceable individually, and in the event of a failure the complete FPP assembly must be replaced.



Step	Action	Value(s)	Yes	No
1	Did you perform the On-Board (OBD) System Check?	-	Go to Step (2)	Go to OBD System Check Section
2	<ul style="list-style-type: none"> <li>DST (Diagnostic Scan Tool) connected and in the system data mode</li> <li>Clear DTC 2126</li> <li>Start and run the engine to full operating temperature</li> <li>Depress the foot pedal from idle to the wide open position several times</li> </ul> Does DTC 2121 re-set?		Go to Step (4)	Go to Step (3)
3	<ul style="list-style-type: none"> <li>Key OFF</li> <li>Slowly depress the foot pedal from idle to the wide-open position while observing the FPP1 and FPP 2 calculated percentage positions</li> </ul> Does the DST display a 20% or more difference between FPP1 and FPP2 calculated positions?		Go to Step (4)	Intermittent problem Go to Intermittent section
4	<ul style="list-style-type: none"> <li>Disconnect FPP sensor connector</li> <li>Jump the pins that lead from the FPP sensor connector to C012 signal pin K and 5-volt supply pin M pin 3</li> </ul> Does the DST show FPP 1 voltage above 0.200volts?	Greater than 0.200 volts	Go to Step (5)	Go to Step (7)
5	<ul style="list-style-type: none"> <li>Inspect the FPP and vehicle interface connectors for damage corrosion or contamination</li> </ul> Did you find a problem?		Repair the circuit as required. See wiring harness repair section	Go to Step (6)
6	<ul style="list-style-type: none"> <li>Replace the FPP sensor Is the replacement complete?</li> </ul>		Go to Step (12)	-
7	<ul style="list-style-type: none"> <li>Key OFF</li> <li>Disconnect ECM connector C001</li> <li>Using a DVOM check for continuity between C017 pin 3 and ECM 5-volt pin 19</li> </ul> Do you have continuity?		Go to Step (8)	Repair the open 5-volt circuit as required. See wiring harness repair section
8	<ul style="list-style-type: none"> <li>Using a DVOM check for continuity between C012 signal pin K and ECM signal pin 9.</li> </ul> Do you have continuity?		Go to Step (9)	Repair the open signal circuit as required. See wiring harness repair section

Step	Action	Value(s)	Yes	No
9	<ul style="list-style-type: none"> <li>Using a DVOM check for continuity between ECM connector signal pin 9 and engine ground</li> </ul> Do you have continuity?		Repair the signal shorted to ground circuit as required. See wiring harness repair section	Go to Step (10)
10	<ul style="list-style-type: none"> <li>Inspect FPP connector and ECM connector pins for damage corrosion or contamination</li> </ul> Did you find a problem?		Repair the circuit as required. See wiring harness repair section	Go to Step (11)
11	<ul style="list-style-type: none"> <li>Replace ECM</li> </ul> Is the replacement complete?		Go to Step (12)	-
12	<ul style="list-style-type: none"> <li>Remove all test equipment except the DST.</li> <li>Connect any disconnected components, fuses, etc.</li> <li>Using the DST clear DTC information from the ECM.</li> <li>Turn the ignition OFF and wait 30 seconds.</li> <li>Start the engine and operate the vehicle to full operating temperature</li> <li>Observe the MIL</li> <li>Observe engine performance and drivability</li> <li>After operating the engine within the test parameters of DTC-2121 check for any stored codes.</li> </ul> Does the engine operate normally with no stored codes?		System OK	Go to OBD System Check

## **DTC 2122-FPP 1 High Voltage (SPN 91:FMI 3)**

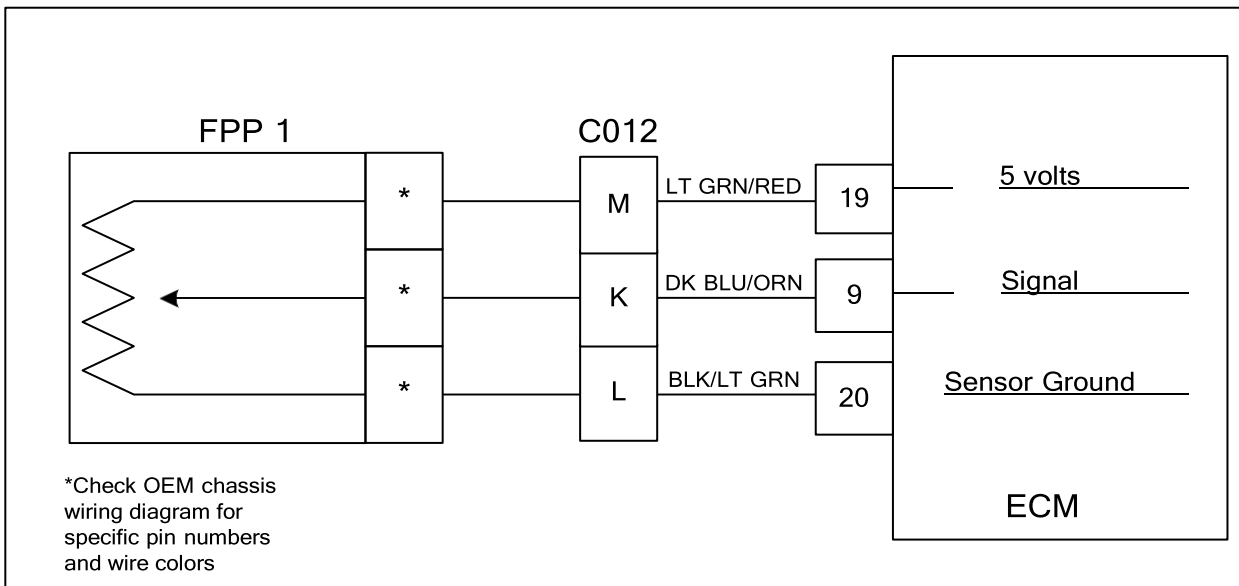

### **Conditions for Setting the DTC**

- Foot Pedal Position
- Check Condition-Key On
- Fault Condition-FPP1 sensor voltage exceeds 4.800 volts
- MIL-On during active fault
- Low rev limit
- Forced idle

### **Circuit Description**

The Foot Pedal Position sensor uses a variable resistor to determine signal voltage based on pedal position. This fault will set if the FPP 1 voltage exceeds 4.800 volts for longer than 0.5 seconds. If the voltage exceeds 4.800 volts the FPP is considered to be out of specification. The MIL command is ON. Forced idle will be in effect during this code set limiting full power output.

### **Diagnostic Aid**

FPP sensors are OEM specific and vary in configuration. The exact wire color and pin numbers for the FPP connection must be verified in the OEM chassis wiring schematic. The FPP sensor used in this system provides two sensors in one packaged assembly. FPP1 and FPP 2 are not serviceable individually, and in the event of a failure the complete foot pedal sensor assembly must be re- placed.

Step	Action	Value(s)	Yes	No
1	Did you perform the On-Board (OBD) System Check?	-	Go to Step (2)	Go to OBD System Check Section
2	<ul style="list-style-type: none"> <li>Key ON, Engine OFF</li> <li>DST (Diagnostic Scan Tool) connected in System Data Mode</li> </ul> Does the DST display FPP voltage of 4.800 volts or greater with the foot pedal in the idle position?	Greater than 4.800 volts	Go to Step (3)	Go to Step (3)
3	<ul style="list-style-type: none"> <li>Slowly increase FPP while observing FPP 1 voltage</li> </ul> Does DST FPP voltage ever exceed 4.800 volts?		Go to step (4)	Intermittent problem Go to Intermittent section
4	<ul style="list-style-type: none"> <li>Disconnect the FPP sensor connector</li> </ul> Does the DST now show FPP 1 voltage below 0.200 volts?	0.200 volts or less	Go to step (5)	Go to step (6)
5	<ul style="list-style-type: none"> <li>Replace FPP sensor</li> </ul> Is the replacement complete?		Go to step (10)	-
6	<ul style="list-style-type: none"> <li>Key OFF</li> <li>Disconnect ECM connector C001</li> <li>Disconnect vehicle interface connector C012</li> </ul> Using a DVOM check continuity between connector C012 pin L and ECM sensor ground pin 20 Do you have continuity?		Go to step (7)	Repair the open ground circuit as required
7	<ul style="list-style-type: none"> <li>Key ON</li> </ul> Using a DVOM check for voltage between the FPP connector pin K and engine ground Do you have voltage?	No voltage	Repair the signal shorted to voltage circuit	Go to step (8)
8	<ul style="list-style-type: none"> <li>Inspect ECM and FPP connectors for damage corrosion or contamination</li> </ul> Did you find a problem?		Repair the circuit as required. See wire harness repair section	Go to step (9)
9	<ul style="list-style-type: none"> <li>Replace ECM</li> </ul> Is the replacement complete?		Go to step (10)	-

Step	Action	Value(s)	Yes	No
10	<ul style="list-style-type: none"> <li>• Remove all test equipment except the DST.</li> <li>• Connect any disconnected components, fuses, etc.</li> <li>• Using the DST clear DTC information from the ECM.</li> <li>• Turn the ignition OFF and wait 30 seconds.</li> <li>• Start the engine and operate the vehicle to full operating temperature</li> <li>• Observe the MIL</li> <li>• Observe engine performance and drivability</li> <li>• After operating the engine within the test parameters of DTC-2122 check for any stored codes.</li> </ul> <p>Does the engine operate normally with no stored codes?</p>		System OK	Go to OBD System Check

## **DTC 2123-FPP 1 Low Voltage (SPN 91:FMI 4)**

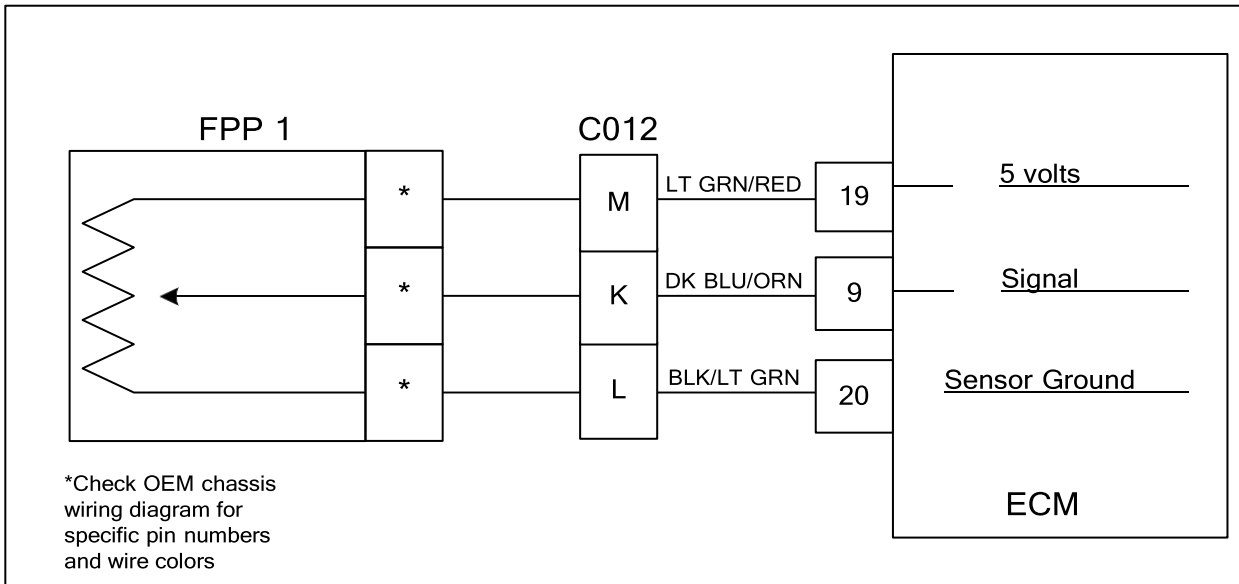

### **Conditions for Setting the DTC**

- Foot Pedal Position
- Check Condition-Key On
- Fault Condition-FPP sensor voltage less than 0.200
- MIL-On during active
- Low rev limit
- Force idle

### **Circuit Description**

The Foot Pedal Position sensor uses a variable resistor to determine signal voltage based on pedal position. This fault will set if the FPP 1 voltage is less than 0.200 volts at any operating condition while the key is on. If the voltage drops below 0.200 volts the FPP is considered to be out of specification. The MIL command is ON. Forced idle will be in effect during this code set limiting full power output.

### **Diagnostic Aid**

FPP sensors are OEM specific and vary in configuration. The exact wire color and pin numbers for the FPP connection must be verified in the OEM chassis wiring schematic. The FPP sensor used in this system provides two sensors in one packaged assembly. FPP1 and FPP 2 are not serviceable individually, and in the event of a failure the complete foot pedal sensor assembly must be replaced.

Step	Action	Value(s)	Yes	No
1	Did you perform the On-Board (OBD) System Check?	-	Go to Step (2)	Go to OBD System Check Section
2	<ul style="list-style-type: none"> <li>Key ON, Engine OFF</li> <li>DST (Diagnostic Scan Tool) connected in System Data Mode</li> </ul> Does the DST display FPP 1 voltage of 0.200volts or less with the foot pedal in the idle position?	0.200 volts or less	Go to Step (3)	Go to Step (3)
3	<ul style="list-style-type: none"> <li>Slowly increase FPP while observing the FPP 1 voltage</li> </ul> Does the DST ever display FPP voltage below 0.200 volts?		Go to step (4)	Intermittent problem Go to Intermittent section
4	<ul style="list-style-type: none"> <li>Disconnect the FPP sensor connector</li> <li>Jump the FPP sensor pins at the FPP 1 connector that lead to C012 5 volt pin M and signal pin K</li> </ul> Does the DST now show FPP 1 voltage above 0.200 volts?	Greater than 0.200 volts	Go to step (5)	Go to step (7)
5	<ul style="list-style-type: none"> <li>Inspect FPP 1 and C012 connectors for damage corrosion or contamination</li> </ul> Did you find a problem?		Repair the circuit as required. See wiring harness repair section	Go to step (6)
6	<ul style="list-style-type: none"> <li>Replace FPP 1 sensor</li> </ul> Is the replacement complete?		Go to step (12)	-
7	<ul style="list-style-type: none"> <li>Key OFF</li> <li>Disconnect ECM connector C001</li> <li>Using a DVOM check for continuity between ECM 5-volt pin 19 and FPP connector pin that leads to C012 pin M</li> </ul> Do you have continuity?		Go to step (8)	Repair the open circuit as required. See wiring harness repair section
8	<ul style="list-style-type: none"> <li>Using a DVOM check for continuity between ECM signal pin 9 and FPP connector pin that leads to C012 pin K</li> </ul> Do you have continuity?		Go to step (9)	Repair the open circuit as required. See wiring harness repair section

Step	Action	Value(s)	Yes	No
9	<ul style="list-style-type: none"> <li>• Key ON</li> <li>• Using a DVOM check for continuity between ECM connector signal pin 9 and engine ground</li> </ul> Do you have continuity?		Repair the signal shorted to ground circuit as required. See wiring harness repair section	Go to step (10)
10	<ul style="list-style-type: none"> <li>• Inspect FPP1, C012 and ECM connectors for damage corrosion or contamination</li> </ul> Did you find a problem?		Repair the circuit as required. See wiring harness repair section	Go to step (11)
11	<ul style="list-style-type: none"> <li>• Replace ECM</li> </ul> Is the replacement complete?		Go to step 12	-
12	<ul style="list-style-type: none"> <li>• Remove all test equipment except the DST.</li> <li>• Connect any disconnected components, fuses, etc.</li> <li>• Using the DST clear DTC information from the ECM.</li> <li>• Turn the ignition OFF and wait 30 seconds.</li> <li>• Start the engine and operate the vehicle to full operating temperature</li> <li>• Observe the MIL</li> <li>• Observe engine performance and drivability</li> <li>• After operating the engine within the test parameters of DTC-2123 check for any stored codes.</li> </ul> Does the engine operate normally with no stored codes?		System OK	Go to OBD System Check



## **DTC 2126-FPP 1 Higher Than FPP 2 (SPN 91:FMI 16)**

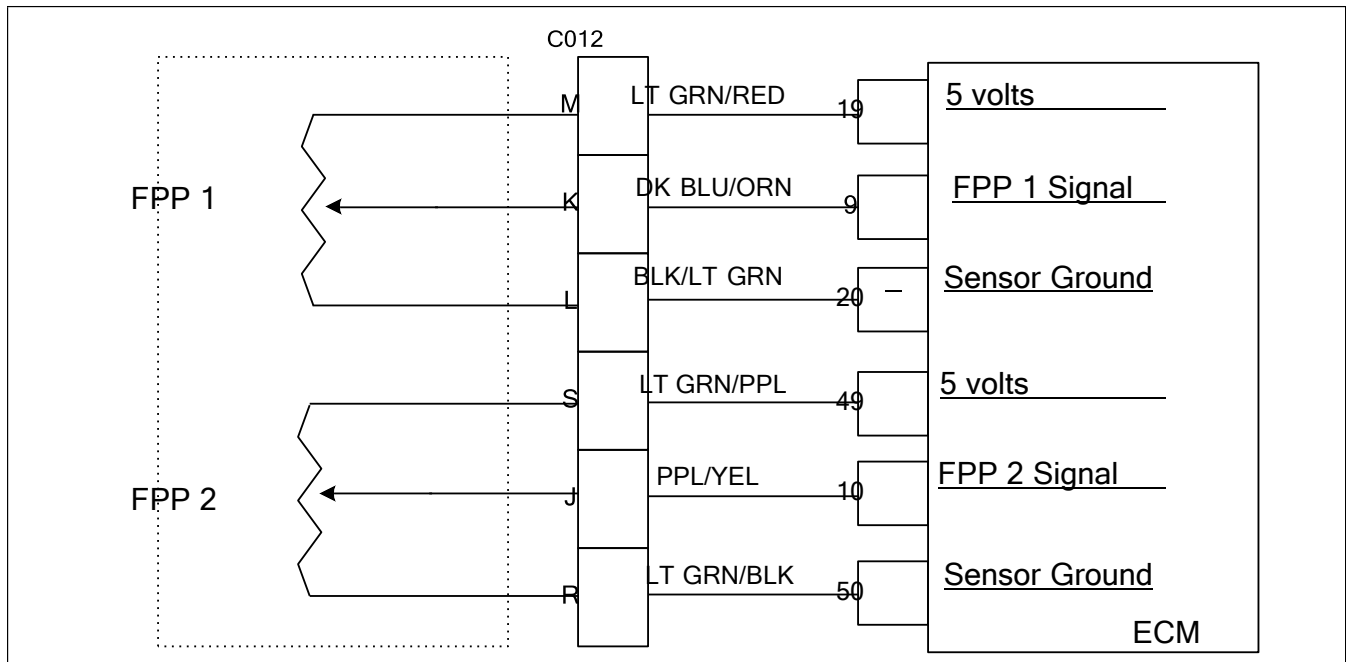

### **Conditions for Setting the DTC**

- Foot pedal position sensor 1 and 2
- Check Condition-Key ON
- Fault Condition-FPP 1 20% higher than FPP 2
- MIL-ON
- Force idle
- Low rev limit

### **Circuit Description**

The foot pedal position sensor uses variable resistors to determine signal voltage based on foot pedal position. Although the voltage outputs are different, the calculated throttle position values should be very close to the same. This fault will set if FPP 1 is 20% or more higher than FPP 2. The MIL command is ON. Forced idle and low rev limit are in effect during this fault limiting full power output.

### **Diagnostic Aid**

FPP sensors are OEM specific and vary in configuration. The exact wire color and pin numbers for the FPP must be verified in the OEM chassis wiring schematic. The FPP sensor used in this system provides two sensors in one packaged assembly. FPP1 and FPP 2 are not serviceable individually, and in the event of a failure the complete FPP assembly must be replaced.

Step	Action	Value(s)	Yes	No
1	Did you perform the On-Board (OBD) System Check?	-	Go to Step (2)	Go to OBD System Check Section
2	<ul style="list-style-type: none"> <li>DST (Diagnostic Scan Tool) connected in System Data Mode</li> <li>Clear DTC 2126</li> <li>Start the engine and run to full operating temperature.</li> <li>Depress the foot pedal from idle to wide open throttle several times.</li> </ul> Does DTC 2126 re-set?		Go to Step (4)	Go to Step (3)
3	<ul style="list-style-type: none"> <li>Key OFF</li> <li>Slowly depress the foot pedal from idle to the wide-open position while observing the FPP1 and FPP 2 calculated percentage positions</li> </ul> Does the DST display a 20% or more difference between FPP1 and FPP2 calculated positions?		Go to Step (4)	Intermittent problem Go to Intermittent section
4	<ul style="list-style-type: none"> <li>Disconnect FPP sensor connector</li> </ul> Does the DST now show FPP 1 voltage below 0.200 volts?	Below 0.200 volts	Go to Step (5)	Go to Step (6)
5	<ul style="list-style-type: none"> <li>Replace the FPP sensor Is the replacement complete?</li> </ul>		Go to Step (10)	-
6	<ul style="list-style-type: none"> <li>Key OFF</li> <li>Disconnect ECM connector C001</li> <li>Disconnect vehicle interface connector C012</li> <li>Using a DVOM check continuity between the interface connector pin L and ECM sensor ground pin 20</li> </ul> Do you have continuity?		Go to Step (7)	Repair the open ground circuit as required
7	<ul style="list-style-type: none"> <li>Key ON</li> <li>Using a DVOM check for voltage between the FPP connector that leads to the vehicle interface connector signal pin K and engine ground</li> </ul> Do you have voltage?	No voltage	Repair the signal shorted to voltage	Go to Step (8)
8	<ul style="list-style-type: none"> <li>Inspect ECM and FPP connectors for damage corrosion or contamination</li> </ul> Did you find a problem?		Repair the circuit as required. See wire harness repair section	Go to Step (9)
9	<ul style="list-style-type: none"> <li>Replace ECM</li> </ul> Is the replacement complete?		Go to Step (10)	-

Step	Action	Value(s)	Yes	No
10	<ul style="list-style-type: none"> <li>• Remove all test equipment except the DST.</li> <li>• Connect any disconnected components, fuses, etc.</li> <li>• Using the DST clear DTC information from the ECM.</li> <li>• Turn the ignition OFF and wait 30 seconds.</li> <li>• Start the engine and operate the vehicle to full operating temperature</li> <li>• Observe the MIL</li> <li>• Observe engine performance and drivability</li> <li>• After operating the engine within the test parameters of DTC-2126 check for any stored codes.</li> </ul> <p>Does the engine operate normally with no stored codes?</p>		System OK	Go to OBD System Check

## **DTC 2127-FPP 2 Low Voltage (SPN 29:FMI 4)**

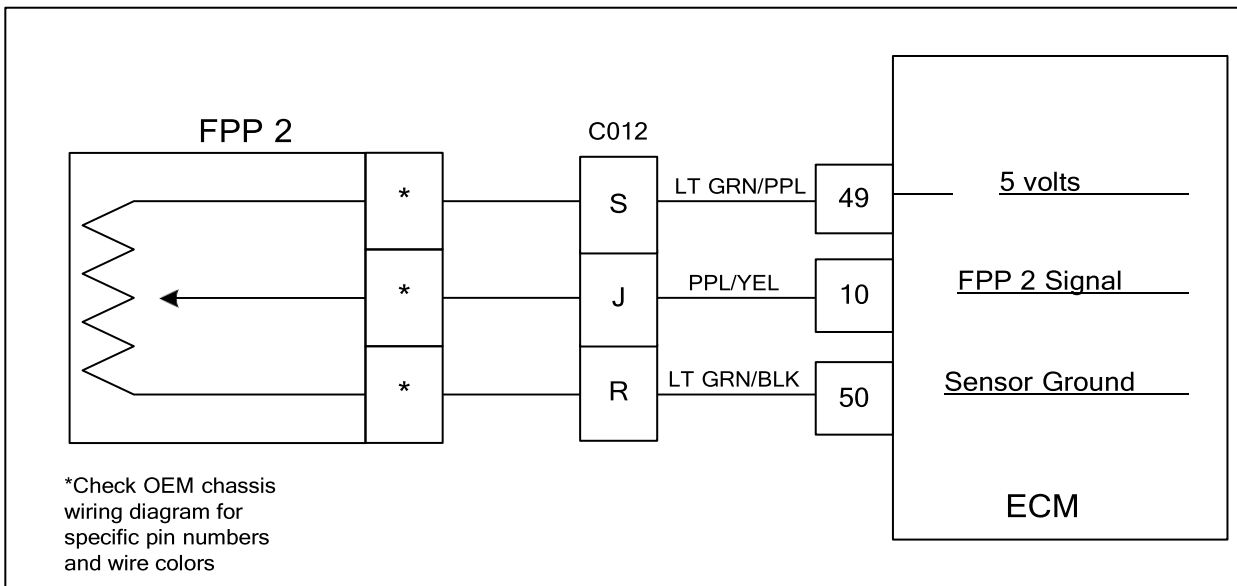

### **Conditions for Setting the DTC**

- Foot Pedal Position
- Check Condition-Key On
- Fault Condition-FPP sensor voltage less than 0.400
- MIL-On
- Low Rev Limit
- Force Idle

### **Circuit Description**

The Foot Pedal Position sensor uses a variable resistor to determine signal voltage based on pedal position. This fault will set if the FPP 2 voltage is less than 0.200 volts at any operating condition while the key is on. If the voltage drops below 0.400 volts the FPP is considered to be out of specification. The MIL command is ON. Low rev limit and forced idle will be effect during this fault limiting power output.

### **Diagnostic Aid**

FPP sensors are OEM specific and vary in configuration. The exact wire color and pin numbers for the FPP must be verified in the OEM chassis wiring schematic. The FPP sensor used in this system provides two sensors in one packaged assembly. FPP1 and FPP 2 are not serviceable individually, and in the event of a failure the complete FPP assembly must be replaced.

Step	Action	Value(s)	Yes	No
1	Did you perform the On-Board (OBD) System Check?	-	Go to Step (2)	Go to OBD System Check Section
2	<ul style="list-style-type: none"> <li>Key ON, Engine OFF</li> <li>DST (Diagnostic Scan Tool) connected in System Data Mode</li> </ul> Does the DST display FPP 2 voltage of less than 0.400 volts with the foot pedal in the idle position?	Less than 0.400 volts	Go to Step (3)	Go to Step (3)
3	<ul style="list-style-type: none"> <li>Slowly increase the FPP while observing the FPP 2 voltage</li> </ul> Does the DST ever display FPP voltage below 0.400 volts?		Go to step (4)	Intermittent problem Go to Intermittent section
4	<ul style="list-style-type: none"> <li>Disconnect the FPP sensor connector</li> <li>Jump the pins from the FPP sensor connector that leads to C012 signal pin J and 5-volt supply pin S</li> </ul> Does the DST now show FPP 1 voltage above 0.400 volts?	Greater than 0.400 volts	Go to step (5)	Go to step (7)
5	<ul style="list-style-type: none"> <li>Inspect the FPP and C012 connectors for damage corrosion or contamination</li> </ul> Did you find a problem?		Repair the circuit as required. See wiring harness repair section	Go to step (6)
6	<ul style="list-style-type: none"> <li>Replace FPP sensor</li> </ul> Is the replacement complete?		Go to step (12)	-
7	<ul style="list-style-type: none"> <li>Key OFF</li> <li>Disconnect ECM connector C001</li> <li>Disconnect the vehicle interface connector C012</li> <li>Using a DVOM check for continuity between C012 pin S and ECM 5-volt pin 49</li> </ul> Do you have continuity?		Go to step (8)	Repair the open 5-volt circuit as required. See wiring harness repair section
8	<ul style="list-style-type: none"> <li>Using a DVOM check for continuity between C012 signal pin J and ECM signal pin 10</li> </ul> Do you have continuity?		Go to step (9)	Repair the open signal circuit as required. See wiring harness repair section

Step	Action	Value(s)	Yes	No
9	<ul style="list-style-type: none"> <li>Using a DVOM check for continuity between ECM connector signal pin 10 and engine ground</li> </ul> Do you have continuity?		Repair the signal shorted to ground circuit as required. See wiring harness repair section	Go to step (10)
10	<ul style="list-style-type: none"> <li>Inspect FPP connector C012 and ECM connector pins for damage corrosion or contamination</li> </ul> Did you find a problem?		Repair the circuit as required. See wiring harness repair section	Go to step (11)
11	<ul style="list-style-type: none"> <li>Replace ECM</li> </ul> Is the replacement complete?		Go to step 12	-
12	<ul style="list-style-type: none"> <li>Remove all test equipment except the DST.</li> <li>Connect any disconnected components, fuses, etc.</li> <li>Using the DST clear DTC information from the ECM.</li> <li>Turn the ignition OFF and wait 30 seconds.</li> <li>Start the engine and operate the vehicle to full operating temperature</li> <li>Observe the MIL</li> <li>Observe engine performance and drivability</li> <li>After operating the engine within the test parameters of DTC-2127 check for any stored codes.</li> </ul> Does the engine operate normally with no stored codes?		System OK	Go to OBD System Check

## **DTC 2128-FPP 2 High Voltage (SPN 29:FMI 3)**

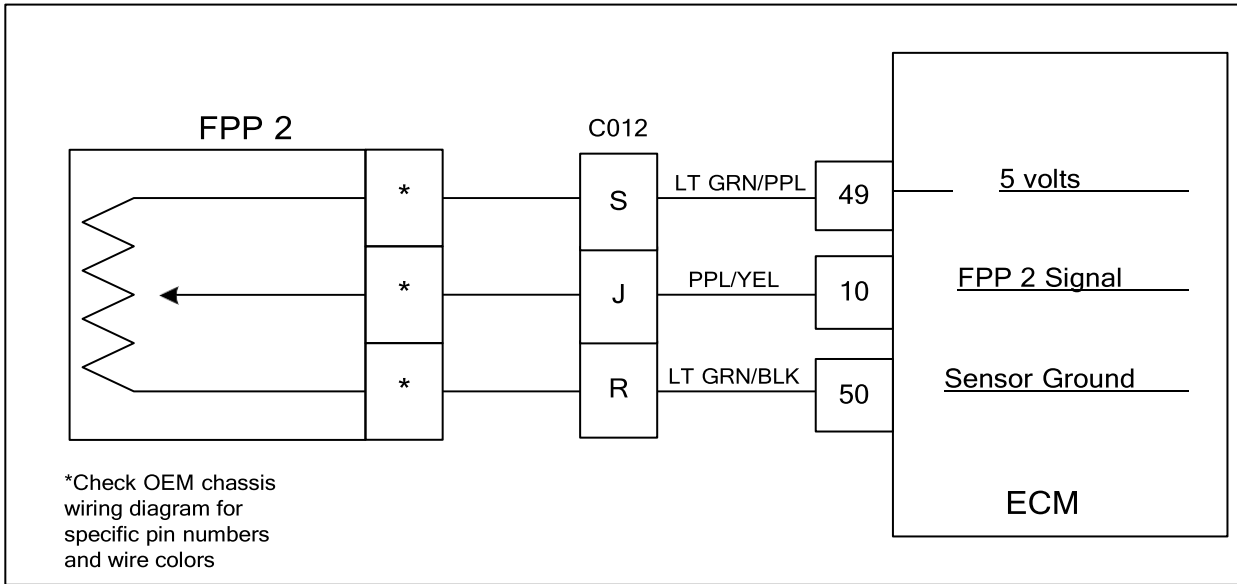

### **Conditions for Setting the DTC**

- Foot pedal position sensor 2
- Check Condition-Key On
- Fault Condition-FPP2 sensor voltage exceeds 4.800 volts
- MIL-On
- Forced idle
- Low rev limit

### **Circuit Description**

The Foot Pedal Position sensor uses a variable resistor to determine signal voltage based on foot pedal position. This fault will set if the FPP 2 voltage exceeds 4.800 volts at any operating condition while the key is on. If the voltage exceeds 4.800 volts the FPP is considered to be out of specification. The MIL command is ON. Forced idle and low rev limit will be in effect limiting power output during this fault.

### **Diagnostic Aid**

FPP sensors are OEM specific and vary in configuration. The exact wire color and pin numbers for the FPP must be verified in the OEM chassis wiring schematic. The FPP sensor used in this system provides two sensors in one packaged assembly. FPP1 and FPP 2 are not serviceable individually, and in the event of a failure the complete FPP assembly must be replaced.

Step	Action	Value(s)	Yes	No
1	Did you perform the On-Board (OBD) System Check?	-	Go to Step (2)	Go to OBD System Check Section
2	<ul style="list-style-type: none"> <li>Key ON, Engine OFF</li> <li>DST (Diagnostic Scan Tool) connected in System Data Mode</li> </ul> Does the DST display FPP voltage of 4.800 volts or greater with the foot pedal in the idle position?	4.800 volts or greater	Go to Step (3)	Go to Step (3)
3	<ul style="list-style-type: none"> <li>Slowly increase FPP while observing FPP 2 voltage</li> </ul> Does DST FPP voltage ever exceed 4.800volts?		Go to step (4)	Intermittent problem Go to Intermittent section
4	<ul style="list-style-type: none"> <li>Disconnect the FPP sensor connector Does the DST now show FPP 2 voltage below 0.200 volts?</li> </ul>	Below 0.200 volts	Go to step (5)	Go to step (6)
5	<ul style="list-style-type: none"> <li>Replace FPP sensor</li> </ul> Is the replacement complete?		Go to step (10)	-
6	<ul style="list-style-type: none"> <li>Key OFF</li> <li>Disconnect ECM connector C001</li> <li>Disconnect vehicle interface connector C012</li> <li>Using a DVOM check continuity between connector C012 pin R and ECM sensor ground pin 50</li> </ul> Do you have continuity?		Go to step (7)	Repair the open ground circuit as required
7	<ul style="list-style-type: none"> <li>Key ON</li> <li>Using a DVOM check for voltage between the FPP connector pin J and engine ground</li> </ul> Do you have voltage?	No voltage	Repair the signal shorted to voltage circuit	Go to step (8)
8	<ul style="list-style-type: none"> <li>Inspect ECM and FPP connectors and pins for damage corrosion or contamination</li> </ul> Did you find a problem?		Repair the circuit as required. See wire harness repair section	Go to step (9)
9	<ul style="list-style-type: none"> <li>Replace ECM</li> </ul> Is the replacement complete?		Go to step (10)	-



Step	Action	Value(s)	Yes	No
10	<ul style="list-style-type: none"> <li>• Remove all test equipment except the DST.</li> <li>• Connect any disconnected components, fuses, etc.</li> <li>• Using the DST clear DTC information from the ECM.</li> <li>• Turn the ignition OFF and wait 30 seconds.</li> <li>• Start the engine and operate the vehicle to full operating temperature</li> <li>• Observe the MIL</li> <li>• Observe engine performance and drivability</li> <li>• After operating the engine within the test parameters of DTC-2128 check for any stored codes.</li> </ul> <p>Does the engine operate normally with no stored codes?</p>		System OK	Go to OBD System Check

## DTC 2135-TPS1/2 Simultaneous Voltages Out of Range (SPN 51:FMI 31)

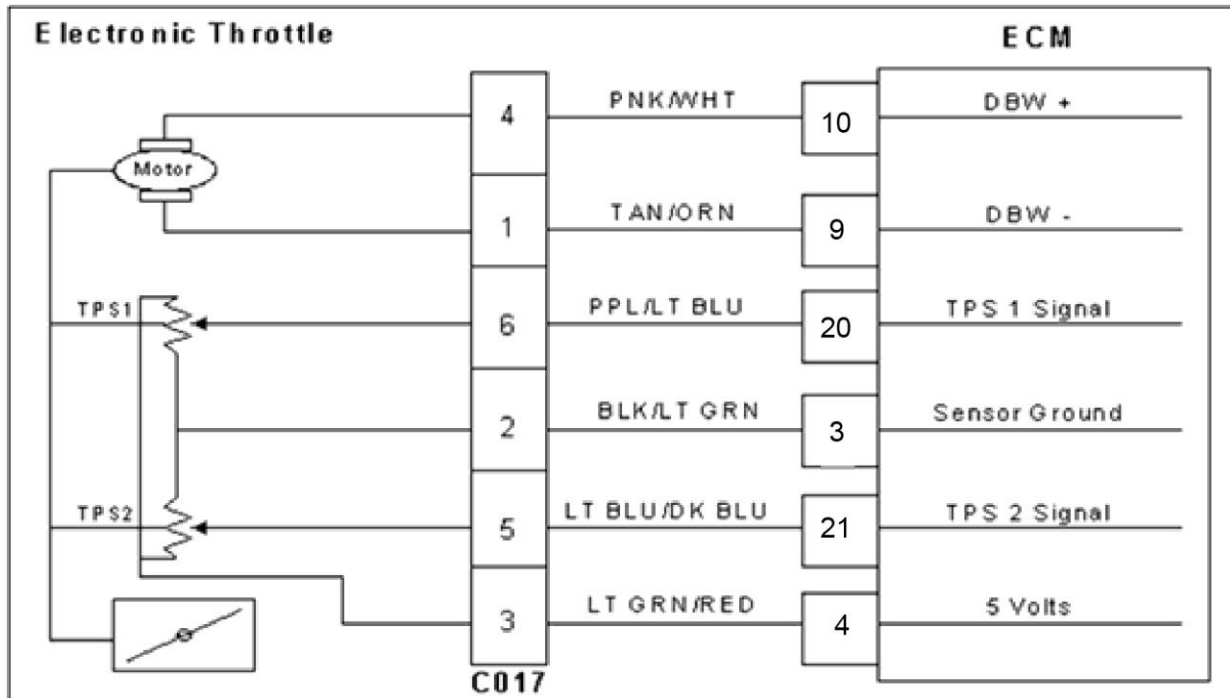

### Conditions for Setting the DTC

- Throttle Position Sensor 1 & 2
- Check Condition-Key ON
- Fault Condition-TPS 1 20% higher than TPS2
- MIL-ON for remainder of key on cycle
- Engine shutdown

### Circuit Description

Dual throttle Position Sensors are used within the throttle that use variable resistors to determine signal voltage based on throttle plate position. TPS 1 will read lower voltage when closed and TPS 2 will read higher voltage when closed. The TPS 1 and TPS 2 percentages are calculated from these voltages. Although the voltages are different, the calculated values for the throttle position percentages should be very close to the same. The TPS values are used by the ECM to determine if the throttle is opening as commanded. The TPS is not serviceable and in the event of a failure the electronic throttle assembly must be replaced. This fault will set if TPS 1 is 20% (or more) higher than TPS 2. At this point the throttle is considered to be out of specification, or there is a problem with the TPS signal circuit. The MIL command is ON and the engine will shut down.

Step	Action	Value(s)	Yes	No
1	Did you perform the On-Board (OBD) System Check?	-	Go to Step (2)	Go to OBD System Check Section
2	<ul style="list-style-type: none"> <li>Key ON, Engine OFF</li> <li>DST (Diagnostic Scan Tool) connected in System Data Mode</li> </ul> Does the DST display more than a 20% difference between TPS 1 and TPS 2?		Go to Step (3)	Intermittent problem Go to Intermittent section
3	<ul style="list-style-type: none"> <li>Key OFF</li> <li>Disconnect electronic throttle connector C017</li> <li>Key ON</li> <li>Change DST mode to DBW (drive by wire) test mode</li> </ul> Is the voltage for TPS 1 less than 0.1 volts?		Go to Step (5)	Go to Step (4)
4	<ul style="list-style-type: none"> <li>Key OFF</li> <li>Disconnect ECM wiring harness connector C001</li> <li>Key ON</li> <li>Using a DVOM check for voltage between ECM connector TPS 1 signal pin 5 and engine ground</li> </ul> Do you have voltage?		Repair the TPS 1 circuit shorted to voltage as necessary. Refer to Wiring Repairs in Engine Electrical.	Go to Step (9)
5	<ul style="list-style-type: none"> <li>Jump TPS 1 signal pin 6 to the 5-volt reference pin 3 at connector C017</li> </ul> Does DST display TPS 1 voltage over 4.900volts?		Go to Step (6)	Go to Step (8)
6	<ul style="list-style-type: none"> <li>Inspect wire terminals at throttle connector for damage corrosion or contamination</li> </ul> Any problems found?		Repair the circuit as necessary. Refer to Wiring Repairs in Engine Electrical.	Go to Step (7)
7	<ul style="list-style-type: none"> <li>Replace the electronic Throttles</li> </ul> Is the replacement complete?		Go to Step (12)	-
8	<ul style="list-style-type: none"> <li>Key OFF</li> <li>Disconnect ECM wire harness connector C001</li> <li>Using a DVOM check for continuity between throttle connector TPS 1 signal pin 6 and ECM connector TPS 1 signal pin 5</li> </ul> Do you have continuity between them?		Go to Step (9)	Repair the open circuit as necessary. Refer to Wiring Repairs in Engine Electrical.

Step	Action	Value(s)	Yes	No
9	<ul style="list-style-type: none"> <li>Using a DVOM check for continuity between throttle connector signal ground pin 2 and ECM connector signal ground pin 3</li> </ul> Do you have continuity between them?		Go to Step (10)	Repair the open circuit as necessary. Refer to Wiring Repairs in Engine Electrical.
10	<ul style="list-style-type: none"> <li>Inspect ECM connector terminals for damage corrosion or contamination.</li> </ul> Any problems found?		Repair the circuit as necessary. Refer to Wiring Repairs in Engine Electrical	Go to Step (11)
11	<ul style="list-style-type: none"> <li>Replace ECM</li> </ul> Is the replacement complete?		Go to Step (12)	-
12	<ul style="list-style-type: none"> <li>Remove all test equipment except the DST.</li> <li>Connect any disconnected components, fuses, etc.</li> <li>Using the DST clear DTC information from the ECM.</li> <li>Turn the ignition OFF and wait 30 seconds.</li> <li>Start the engine and operate the vehicle to full operating temperature</li> <li>Observe the MIL</li> <li>Observe engine performance and drivability</li> <li>After operating the engine within the test parameters of DTC-221 check for any stored codes.</li> </ul> Does the engine operate normally with no stored codes?		System OK	Go to OBD System Check

## **DTC 2229-BP High Pressure (SPN 108:FMI 0)**

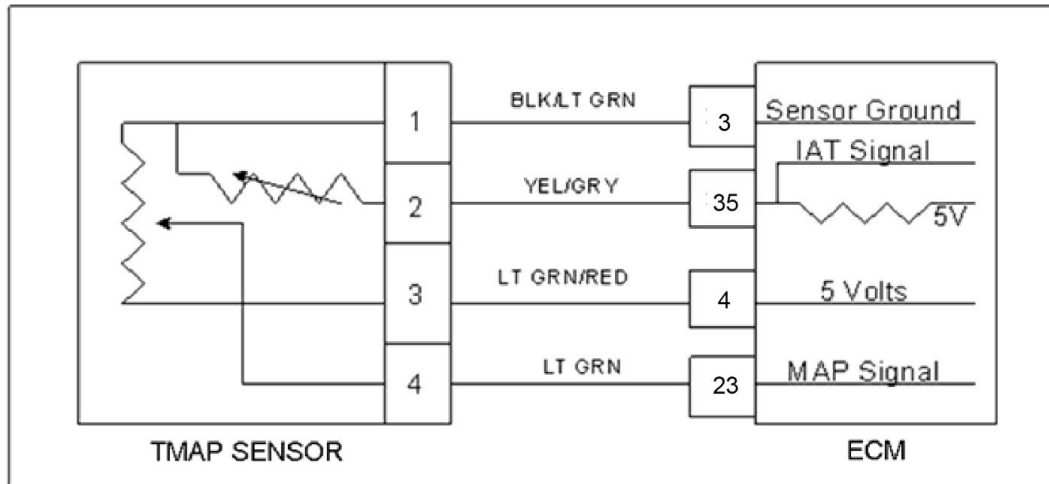

### **Conditions for Setting the DTC**

- Barometric Pressure
- Check Condition-Key ON
- Fault Condition-BP greater than 16 psia
- MIL-ON for active fault
- Adaptive-Disabled

### **Circuit Description**

The BP (Barometric Pressure) is estimated from the TMAP sensor. The barometric pressure value is used for fuel and airflow calculations. This fault sets in the event the BP value is out of the normal range.

Step	Action	Value(s)	Yes	No
1	Did you perform the On-Board (OBD) System Check?	-	Go to Step (2)	Go to OBD System Check Section
2	<ul style="list-style-type: none"> <li>• Key ON</li> <li>• DST (Diagnostic Scan Tool) connected in System Data Mode</li> </ul> Does DST display MAP pressure of 16 psia or greater?		Go to Step (3)	Intermittent problem Go to Intermittent section
3	<ul style="list-style-type: none"> <li>• Replace TMAP sensor. Is the repair complete?</li> </ul>		Go to Step 4	-
4	<ul style="list-style-type: none"> <li>• Remove all test equipment except the DST.</li> <li>• Connect any disconnected components, fuses, etc.</li> <li>• Using the DST clear DTC information from the ECM.</li> <li>• Turn the ignition OFF and wait 30 seconds.</li> <li>• Start the engine and operate the vehicle to full operating temperature</li> <li>• Observe the MIL</li> <li>• Observe engine performance and drivability</li> <li>• After operating the engine within the test parameters of DTC-2229 check for any stored codes.</li> </ul> Does the engine operate normally with no stored codes?		System OK	Go to OBD System Check

# Definitions

**Air Valve Vacuum (AVV):** The vacuum signal taken from below the air valve assembly and above the throttle butterfly valve.

**ADP:** Adaptive Digital Processor.

**Air/Fuel Ratio:** The amount or balance of air and fuel in the air fuel mixture that enters the engine.

**Analog Voltmeter:** A meter that uses a mechanical needle to point to a value on a scale of numbers. It is usually of the low impedance type and used to measure voltage and resistance.

**Aromatics:** Pertaining to or containing the six-carbon ring characteristic of the benzene series. Found in many petroleum distillates.

**Backfire:** Combustion of the air/fuel mixture in the intake or exhaust manifolds. A backfire can occur if the intake or exhaust valves are open when there is a mis-timed ignition spark.

**Benzene:** An aromatic (C<sub>6</sub>H<sub>6</sub>). Sometimes blended with gasoline to improve anti-knock value. Benzene is toxic and suspected of causing cancer.

**Bi-Fueled:** A vehicle equipped to run on two fuels. Blow-By: Gases formed by the combustion of fuel and air, which ordinarily should exert pressure only against the piston crown and first compression ring. When rings do not seal, these gases escape or "blow by" the side of the piston into the crankcase.

**BTU:** British Thermal Unit. A measurement of the amount of heat required to raise the temperature of 1lb. of water 1 degree F.

**Butane:** An odorless, colorless gas, C<sub>4</sub>H<sub>10</sub> found in natural gas and petroleum. One of the five LP gases.

**CAFE:** Corporate Average Fuel Economy.

**CARB:** California Air Resources Board.

**Carbon Monoxide (CO):** A chemical compound of a highly toxic gas that is both odorless and colorless.

**Carburetor:** An apparatus for supplying an internal-combustion engine a mixture of vaporized fuel and air.

**Cathode Ray Tube:** A vacuum tube in which cathode rays usually in the form of a slender beam are projected on a fluorescent screen and produce a luminous spot.

**Circuit:** A path of conductors through which electricity flows.

**Closed Loop Operation:** Applies to systems utilizing an oxygen sensor. In this mode of operation, the system uses oxygen sensor information to determine air/fuel ratio. Adjustments are made accordingly and checked by comparing the new oxygen sensor to previous signals. No stored information is used.**CNG:** Compressed Natural Gas. **CKP:** Crankshaft Position Sensor

**Ethanol:** Grain alcohol (C<sub>2</sub>H<sub>5</sub>OH), generally produced by fermenting starch or sugar.

**Evaporative Emissions Controls:** An automotive emission

**CMP:** Camshaft Position Sensor

**Conductor:** A material, normally metallic, that permits easy passage of electricity.

**Contaminants:** Impurities or foreign material pre-sent in fuel.

**Control Module:** One of several informal names for a solid-state microcomputer which monitors engine conditions and controls certain engine functions; i.e. air/fuel ratio, injection and ignition time, etc. The formal name and the one used throughout this manual is ECM, or Engine Control Module.

**Converter:** A LPG fuel system component containing varying stages of fuel pressure regulation combined with a vaporizer.

**Cryogen:** A refrigerant used to obtain very low temperatures.

**Current:** The volume or flow of electrons through a conductor. Measured in amperes or amps.

**DBW:** Drive By Wire

**Dedicated Fuel System:** A motor fuel system designed to operate on only one fuel type.

**Diaphragm:** A thin, flexible membrane that separates two chambers. When the pressure in one chamber is lower than in the other chamber, the diaphragm will move toward the side with the low pressure.

**Diaphragm Port:** The external port located at the fuel inlet assembly and connected to the vacuum chamber above the air valve diaphragm.

**DLC:** Data Link Connector.

**DTC:** Diagnostic Trouble Code **DST:** Diagnostic Scan Tool.

**DVOM:** Digital Volt/ohm Meter. A meter that uses a numerical display in place of a gauge and is usually of the high impedance type.

**ECT:** Engine Coolant Temperature.

**ECM:** Electronic Control Module

**ECOM:** A DLC cable supporting CAN and serial communication with a PSI/E Controls ECM.

**EFI:** Electronic Fuel Injection. A fuel injection system, which uses a microcomputer (ECM) to determine and control the amount of fuel, required by, and injected into, a particular engine.

**EGO:** Exhaust Gas Oxygen, used to describe a sensor. Also known as "HEGO" (Heat Exhaust Gas Oxygen) sensor, "O<sub>2</sub>" or "Oxygen sensor.

**EGR:** Exhaust Gas Recirculation.

**EPA:** Environmental Protection Agency: A regulating agency of the Federal government which, among other duties, establishes and enforces automotive emissions standards

control system designed to reduce hydrocarbon emissions by trapping evaporated fuel vapors from the fuel system.



**Excess Flow Valve:** A check valve that is caused to close by the fuel when the flow exceeds a pre-determined rate.

**FTV:** Fuel Trim Valve.

**FFV:** Flexible Fuel Vehicle.

**Firing Line:** The portion of an oscilloscope pattern that represents the total amount of voltage being expended through the secondary circuit.

**FMVSS:** Federal Motor Vehicle Safety Standards.

**FPP:** Foot Pedal Position Sensor

**Fuel Injector:** a spring loaded, electromagnetic valve which delivers fuel into the intake manifold, in response to an electrical input from the control module.

**Fuel Lock:** A solenoid-controlled valve located in the fuel line to stop the flow when the engine stops or the ignition switch is off.

**Gasohol:** 10 percent ethanol, 90 percent gasoline. Often referred to as E-10.

**Gasoline:** A motor vehicle fuel that is a complex blend of hydrocarbons and additives. Typical octane level is 89.

**GCP:** Spectrum III (90-pin) ECM.

**Greenhouse Effect:** A scientific theory suggesting that carbon dioxide from the burning of fossil fuels is causing the atmosphere to trap heat and cause global warming.

**HC:** Hydrocarbon. An organic chemical compound.

**HD 10:** A fuel of not less than 80% liquid volume propane and not more than 10% liquid volume propylene.

**HD 5:** A fuel of not less than 90% liquid volume propane and not more than 5% liquid volume propylene.

**HDV:** Heavy Duty Vehicle.

**Heavy Ends:** A term used to describe the build up of wax-like impurities that fall out of LPG when vaporized.

**HEGO:** Heated Exhaust Gas Oxygen, used to describe a sensor. Also known as "EGO" (Exhaust Gas Oxygen sensor), "O<sub>2</sub>" or "Oxygen sensor".

**Hg:** Chemical symbol for the element mercury. Used in reference to a measure of vacuum (inches of Hg).

**Histogram:** The graphical version of a table which shows what proportion of values fall into specific categories over a specific period of time.

**Hydrocarbon:** A chemical compound made up of hydrogen and carbon (HC). Gasoline and almost all other fuels are hydrocarbons.

**Hydrostatic Relief Valve:** A pressure relief device installed in the liquid LPG hose on a LPG fuel system.

**IAT:** Intake Air Temperature

**Ideal Mixture:** The air/fuel ratio at which the best compromise of engine performance to exhaust emissions is obtained. Typically 14.7:1.

**Ignition Reserve:** The difference between available voltage and the required voltage.

**ILEV:** Inherently Low Emission Vehicle.

**Impedance:** A form of opposition of AC electrical current flow (resistance) measured in ohms.

**Insulation:** A nonconductive material used to cover wires in electrical circuits to prevent the leakage of electricity and to protect the wire from corrosion.

**Intercept:** An electrical term for a type of splice where the original circuit is interrupted and redirected through another circuit.

**Knock:** Sound produced when an engine's air/fuel mixture is ignited by something other than the spark plug, such as a hot spot in the combustion chamber. Also caused by a fuel with an octane rating that is too low and/or incorrect ignition timing. Also called detonation or ping.

**Lambda Sensor:** A feedback device, usually located in the exhaust manifold, which detects the amount of oxygen present in exhaust gases in relation to the surrounding atmosphere. (See HEGO).

**LDV:** Light Duty Vehicle.

**Lean Mixture:** An air to fuel ratio above the stoichiometric ratio; too much air.

**LEV:** Low Emission Vehicle.

**Limp-in or Limp Home:** A mode where the ECM or a component has failed, but the vehicle remains operational although the engine may operate minimally. This term may also describe the drivability characteristics of a failed computer system.

**Liquid Petroleum Gas (LPG):** A fuel commonly known as propane consisting mostly of propane (C<sub>3</sub>H<sub>8</sub>), derived from the liquid components of natural gas stripped out before the gas enters the pipeline, and the lightest hydrocarbons produced during petroleum refining. Octane level of LPG is 107.

**LPG:** Liquefied Petroleum Gas.

**M85:** A blend of gasoline and methanol consisting of 85% methanol and 15% gasoline.

**Measurements of Pressure:** 1 PSI = 2.06" Hg (mercury) = 27.72" H<sub>2</sub>O (water column). At sea level atmospheric pressure is 29.92" Hg.

**Methanol:** Known as wood alcohol ( $\text{CH}_3\text{OH}$ ), a light, volatile, flammable alcohol commonly made from natural gas.

**MIL:** Malfunction Indicator Lamp.

**Misfire:** Failure of the air/fuel mixture to ignite during the power stroke.

**Mixer:** Fuel introduction device that does not include a throttle plate.

**MFI:** Multiport Fuel Injection. A fuel injection system that uses one injector per cylinder mounted on the engine to spray fuel near the intake valve area of combustion chamber.

**MSV:** Manual Shut-Off Valve. Refers to the manually operated valve on the LPG tank.

**MTBE:** Methyl Tertiary Butyl Ether. Oxygenate add to gasoline to reduce harmful emissions and to improve the octane rating.

**Multi-fuel System:** A motor fuel system designed to operate on two different fuels, such as LPG and gasoline.

**Natural Gas:** A gas formed naturally from buried organic material, composed of a mixture of hydro-carbons, with methane ( $\text{CH}_4$ ) being the dominant component.

**NGV:** Natural Gas Vehicle. **NOX:** See Oxides of Nitrogen.

**OBD:** On Board Diagnostic

**Octane Rating:** The measurement of the antiknock value of a motor fuel.

**OEM:** Original Equipment Manufacturer, the vehicle manufacturer.

**Open-Loop:** An operational mode during which control module memory information is used to determine air/fuel ratio, injection timing, etc., as opposed to actual oxygen sensor input.

**Orifice:** A port or passage with a calibrated opening designed to control or limit the amount of flow through it.

**Oscilloscope:** An instrument that converts voltage and frequency readings into traces on a cathode ray tube (also see Cathode Ray Tube).

**Oxides of Nitrogen:** Chemical compounds of nitrogen bonded to various amounts of oxygen (NOX). A chief smog forming-agent.

**Oxygen Sensor:** An automotive fuel system that produces a signal in accordance with the oxygen content of the exhaust gas. (See Lambda Sensor).

**Oxygenate:** Oxygenates (such as MTBE, ethanol, and methanol) added to gasoline to increase the oxygen content and therefore reduce exhaust emissions.

**Ozone:** A radical oxygen molecule ( $\text{O}_3$ ) that is found in the upper atmosphere and filters out ultraviolet radiation from the sun. Ground level ozone is formed by NOX, during the formation of photo-chemical smog.

**Particulates:** Microscopic pieces of solid or liquid substances such as lead and carbon that are discharged into the atmosphere by internal combustion engines.

**Positive Crankcase Ventilation (PCV):** An automotive emission control system designed to reduce hydrocarbon emissions by routing crankcase fumes into the intake manifold rather than to the atmosphere.

**Power Derate:** A mode of reduced engine power output for the purposes of protecting engine components during a failure or malfunction.

**Pressure Differential:** The differential between atmospheric pressure and intake manifold (referred to as vacuum) pressure.

**Pressure Regulator:** A device to control the pressure of fuel delivered to the fuel injector(s).

**Primary Circuit:** The low-voltage or input side of the ignition coil.

**Propane:** An odorless and colorless gas,  $\text{C}_3\text{H}_8$ , found in natural gas and petroleum.

**Psia:** pounds per square inch absolute

**PTV:** Pressure Trim Valve

**Reactivity:** Refers to the tendency of an HC in the presence of NOX and sunlight to cause a smog-forming reaction. The lighter the HC, the lower re-activity tends to be.

**Regulator:** An assembly used to reduce and control the pressure of a liquid or vapor.

**Resistance:** The opposition to the flow of current in an electrical circuit. Measured in ohms.

**Rest Pressure:** Fuel pressure maintained within the system after engine shutdown.

**Rich Mixture:** An air to fuel ratio below the stoichiometric ratio; too much fuel.

**SAE:** Society of Automotive Engineers.

**Secondary Circuit:** The high-voltage output side of the ignition coil.

**SEFI or SFI:** Sequential Electronic Fuel Injection or Sequential Fuel Injection.

**Sensors:** Devices that provide the control module with engine information as needed to properly control engine function.

**Spark Line:** The portion of an oscilloscope pattern that represents the time during which the air/fuel mixture is being burned in the combustion chamber.

**Splice:** An electrical term for the joining of two or more conductors at a single point.

**Stoichiometric Ratio:** An ideal fuel/air ratio for combustion in which all of the fuel and most of the oxygen will be burned.

**Sulfur Oxides:** Chemical compounds where sulfur is bonded to oxygen produced by the combustion of gasoline or any other fuel that contains sulfur. As sulfur oxides combine with water in the atmosphere to form sulfuric acid.

**System Pressure:** The fuel pressure maintained in the system during normal engine operation.

**Tap:** An electrical term for a type of splice where the original circuit is not interrupted.

**TBI:** Throttle Body Injection. Any of several injection systems that have the fuel injector(s) mounted in a centrally located throttle body.

**Throttle Body:** Controls engine RPM by adjusting the engine manifold vacuum to the mixer. Consists of a housing shaft, throttle liner and butterfly valve.

**TLEV:** Transitional Low Emission Vehicle.

**TMAP:** Combined Air Inlet and Manifold Pressure Sensor.

**Toluene:** A liquid aromatic hydrocarbon  $C_7H_8$ .

**TPS:** Throttle Position Sensor.

**TSB:** Technical Service Bulletin.

**ULEV:** Ultra Low Emission Vehicle.

**USB:** Universal Serial Bus. A plug or interface supplied on most personal computers.

**Vaporization:** A process in which liquid changes states into gas.

**Venturi Air Valve Vacuum (VAVV):** An amplified air valve vacuum signal coming from the venturi area of the mixer, directly exposed to airflow before the addition of vaporized LPG.

**Volt/ohmmeter (VOM):** A combination meter used to measure voltage and resistance in an electrical circuit. Available in both analog and digital types. May also be referred to as AVOM and DVOM.

**Voltage:** The electrical pressure that causes current to flow in a circuit. Measured in volts.

**Voltage Drop:** A lowering of the voltage in a circuit when resistance or electrical load is added.

**Voltmeter:** A meter that uses a needle to point to a value on a scale of numbers usually of the low impedance type; used to measure voltage and resistance.

**VSS:** Vehicle Speed Sensor

**Xylene:**  $C_6H_4(CH_3)_2$ . Any of three toxic, flammable, and oily isomeric aromatic hydrocarbons that are dimethyl homologues of benzene and usually obtained from petroleum or natural gas distillates.

**ZEV:** Zero Emission Vehicle.



**POWER SOLUTIONS  
INTERNATIONAL**

---

Power Solutions International, Inc

(PSI)201 Mittel Drive

Wood Dale, IL

60191USA

630-350-9400